

This Owner's Manual is provided and hosted by [Appliance Factory Parts](http://ApplianceFactoryParts.com).

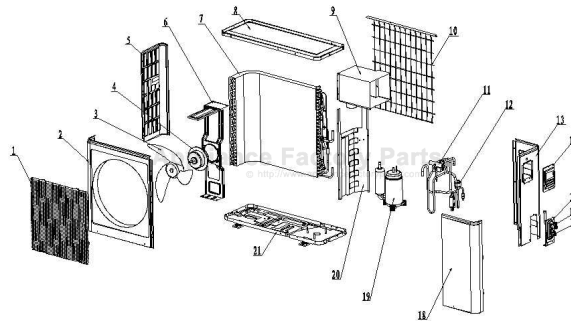

TURBO AIR TAS18EH Owner's Manual

[Shop genuine replacement parts for TURBO AIR
TAS18EH](#)



[Find Your TURBO AIR Air Conditioner Parts - Select From 72 Models](#)

----- Manual continues below -----

SERVICE MANUAL

DC Inverter Multi-Split Air-Condition Unit



TAS-09EH/0

TAS-12EH/0

TAS-18EH/0
TAS-18MVH/0

TAS-24EH/0

TAS-24MVH/O

Indoor Unit	Outdoor Unit
TAS-09MVH	TAS-18MVH/0 TAS-24MVH/0
TAS-12MVH	
TAS-09EH	TAS-09EH/0
TAS-12EH	TAS-12EH/0
TAS-18EH	TAS-18EH/0
TAS-24EH	TAS-24EH/0

REFRIGERENT	
R410A	HEAT PUMP

Table of Contents

1.	INTRODUCTION	1-1
2.	PRODUCT DATA SHEET	2-1
3.	RATING CONDITIONS	3-1
4.	OUTLINE DIMENSIONS	4-1
5.	PERFORMANCE DATA	5-1
6.	PRESSURE CURVES	6-1
7.	ELECTRICAL DATA.....	7-1
8.	WIRING DIAGRAMS	8-1
9.	REFRIGERATION DIAGRAMS	9-1
10.	TUBING CONNECTIONS	10-1
11.	CONTROL SYSTEM	11-1
12.	TROUBLESHOOTING	12-1
13.	EXPLODED VIEWS AND SPARE PARTS LISTS.....	13-1
14.	APPENDIX A	

1. INTRODUCTION

1.1 General

The new CMV and CS is a high efficiency DC inverter technology outdoor unit, since it's a lego concept unit, it can be matched to several inverter indoor units such as wall mounted type with a capacity range of 9000 – 12000 BTU for each single indoor unit.

1.2 Main Features

- DC Inverter
- R410a
- sine wave form and 120 degree rectangular wave form in compressor driver
- sensor less inverter compressor driver
- high speed calculation for accurate sine wave form vector control
- smart PFC control
- fuzzy logic control
- High SEER
- Lego Concept
- Pre-Charged.
- Cooling operation at outdoor temperature down to 50°F
- Heating operation at outdoor temperature down to 5°F.
- Variable Speed outdoor fan.
- Low noise level
- EEV for each indoor unit

1.3 Tubing Connections

Flare type interconnecting tubing to be produced on site.
For further details please refer to APPENDIX A on this manual, and to the relevant indoor service Manual,

1.4 Inbox Documentation

Each indoor unit is supplied with its own installation and operation manuals.

2. PRODUCT DATA SHEET

2.1 Outdoor unit data

2.1.1 DC Inverter 1:1.

Item	DC INVERTER 1:1			
	Inverter 9K	Inverter 12K	Inverter 18K	Inverter 24K
Capacity (BTU)				
Cooling	9000	12000	18000	24000
Heating	11000	15000	19000	24500
SEER	18.00	18.00	17.17	15.69
HSPF	8.6	8.7	8.7	8.5
EER Cooling/COP Heating	4.0/3.7	4.0/3.6	3.60/3.60	2.87/3.18
Op Range Cool °F	5~131	5~131	5~131	5~131
Op Range Heat °F	minus 4 ~ 109	minus 4 ~ 109	minus 4 ~ 109	minus 4 ~ 109
Remote control setting temp.range °F	61~90	61~90	61~90	61~90
Dehumidification (Pts/hr)	1.58	2.11	2.989	4.4
Voltage	115/60	115/60	230/60	230/60
Current (A) Rated/Max Cooling	5.5/9.32	7.53/10.8	5.929/10.1	11.09/12.22
Heating	7.1/9.8	10.4/13.0	6.732/9.31	10.24/12.23
Power Consumption (KW)Rated/Max Cooling	0.61/1.06	0.862/1.236	1.345/2.3	2.504/2.765
Heating	0.8/1.11	1.19/1.496	1.532/2.124	2.314/2.768
Max Overload Protection	20	20	20	25
Indoor Air Circulation: L / M / H(CFM)	212/270/315	341/382/430	441/530/618	518/588/677
Indoor Noise level dB(A): L / M / H	42/38/35	42/38/35	50/47/44	50/47/44
Outdoor Fan Speed (RPM)	100~900	100~900	100~900	100~900
Outdoor Noise Level dB(A)	~ 57	~ 57	~ 57	~ 57
Indoor Fan Speeds	950/1150/1300	750/900/1000	950/1100/1230	1080/1180/1280
Connection Method	Flare	Flare	Flare	Flare
Max Pipe Length (Ft.)	82ft/25m	82ft/25m	82ft/25m	82ft/25m
Max Elevation (Ft.)	32.8 Ft/10m	32.8 Ft/10m	32.8 Ft/10m	32.8 Ft/10m
Pipe Size (In.)	1/4" / 3/8"	1/4" / 1/2"	3/8" / 5/8"	3/8" / 5/8"
Service Port Connection (In.)	1/2"	1/2"	1/2"	1/2"
Indoor Dimensions W x D x H(In.)	33.4×13.4×9.8	38.4×14.3×11.0	45.8×15.2×12.0	52.0×15.6×12.0
Indoor Package Dimensions W x D x H(In.)	33.9×13.8×10.4	39.0×14.8×11.8	46.3×15.6×12.6	52.6×16.1×12.6
Indoor Net Weight (lbs.)	22	31	40	44
Indoor Gross Weight(lbs.)	26	37	51	55
Outdoor Dimensions W x D x H(In.)	35.6×12.7×22.6	38.6×15.7×26.0	38.2×15.6×29.9	40.2×17.1×34.1
Outdoor Package Dimensions W x D x H(In.)	36.2×13.2×23.0	39.2×16.3×26.8	39.0×16.1×30.3	40.6×17.3×37.8
Outdoor Net Weight (lbs.)	73	106	123	143
Outdoor Gross Weight(lbs.)	77	117	132	154
Refrigerant	R410A	R410A	R410A	R410A

2.1.2 DC Inverter 1:2

		TAS-18MVH/O	TAS-24MVH/O	
Function		Heat Pump	Heat Pump	
Rated Voltage		208-230 VAC	208-230 VAC	
Rated Frequency		60 Hz	60 Hz	
Circuit Breaker Size		20A	30A	
Op Range Cool °F		5~131	5~131	
Op Range Heat °F		minus 4 ~ 109	minus 4 ~ 109	
Rated Current (RLA) (Heating/Cooling)		6 / 6.7 A	8 / 8.7 A	
Refrigerant (lbs)		R410A / 3.88	R410A / 6.61	
outdoor	Cooling	Rated Capacity (Btu)	18,000	24,000
		Capacity Invert Range (W)	5000 (1650-7100)	6400 (1750-8300)
		Input / Actual Input (W)	1380/1450	1830/1882
		Max. Power (W)	2420	2990
		Max Current (A)	10.5	13
		SEER	14.8	15.6*
	Heating	Rated Capacity (Btu)	22,000	25,000
		Capacity Invert Range (W)	5800 (1790-7800)	7200 (2000-8400)
		Input / Actual Input (W)	1,550 / 1,580	2,000 / 2,060
		Max. Power (W)	2579	3,200
		Max Current (A)	11.3	13.9
		Declared COP / Actual COP (w/w.h.)	3.75 / 3.65	3.5 / 3.4
	Fan Motor	Model	YDK-60A-6C	YDK-60A-6C
		Input (W)	196	196
		Capacitor (UFD)	4 / 450 VAC	4/ 450 VAC
		Fan Motor FLA (A)	0.98	0.98
		Fan Speed (RPM)	900/750/500	900/750/500
	Outdoor Fan	Fan Type	Axial	Axial
		Fan Blade Diameter (in)	18.1	18.5
		Air Flow Volume of Outdoor Unit (CFM)(M³/h)	2800	3200
	Compressor	Model	C-6RZ146H1A	C-7VRN153HOW
		TYPE	DC	DC
		Brand	Sanyo	Sanyo
		Capacity (W)	6420	7110
		Input (W)	1635	1770
	Condenser	Number of Rows	2-26	2-26
		Tube Pitch x Row Pitch	1 x .866 in	1 x .866 in
		Fin spacing	0.0708 in	0.0708 in
		Fin Type	Louvered Fin	Louvered Fin
		Tube Outside Dia. and Type	0.375" Rifled Tube	0.375" Rifled tube
Coil Length x Height x Width		28.66 x 25.6 x .866 28.66 x 25.6 x .988	30.23 x 31.96 x .866 31.57 x 31.96 x .866	
Number of circuits		4	4	
Dimensions	Unit Dimensions (W x H x D) (in)	36.5 x 14.25 x 27.6	37.8x13.54x33.31	
	Packing dimensions (W x H x D) (in)	39 x 16.14 x 30.32	41.73 x 18.5 x 36.41	
	Net / Gross Weight (lb)	114.64 / 123.47	163.14 / 185.18	
Connection	Design Length	16.4'	16.4'	
	Max Line Set Height	16.4'	16.4'	
	Max Line Set Length	49.21'	49.21'	
	Charge over Design Length	0.20 oz / Ft.	0.20 oz / Ft.	
	Connection Pipes	1/4" / 3/8"	1/4" x 1/2"	
	Design Pressure (PSI)	623.66	623.66	

2.2 Indoor Units Data

2.2.1 TAS-09MVH Specifications

Indoor			TAS-09MVH
	FAN MOTOR	Model	YDK-16-4C
		Input (W)	54
		Capacitor (UFD)	1.2/450VAC
		Fan Motor FLA (A)	0.25
		Speed (Hi/Med/Low) (RPM)	1150 / 950 / 750
	Evaporator	Number of rows	22
		Tube pitch row / pitch (in)	.69 / .50
		Fin spacing (in)	0.0614
		Fin Type	Louvered Fin
		Tube outside dia.(in) / Type	0.2756 Rifled Tube
		Coil Length x height x width (in)	25.39 x 11.06 x 1
	Air Flow (Hi/Med/Low) (CFM)		353 / 306 / 194
	Noise Level (dB(A))		≤42
	Fan Type		Cross Flow
	Fan Diameter (in)		3.661
	Fan Length (in)		24.921
	Design Pressure (PSI)		551.14
	Unit Dimensions (W x H x D) (in)		31.1 x 10.63 x 8.27
	Packing Dimensions W x H x D) (in)		33.86 x 13.78 x 10.43
Net / Gross Wt (lbs)		26.45 / 30.86	
Dehumidifying Volume (pt/hr)		1.8	
Auto-restart		YES	

2.2.2 TAS-12MVH Specifications

Indoor			TAS-12MVH
	FAN MOTOR	Model	YDK-16-4C
		Input (W)	54
		Capacitor (UFD)	1.2/450VAC
		Fan Motor FLA (A)	0.25
		Speed (Hi/Med/Low) (RPM)	1200 / 950 / 850 (Cooling) 1200 / 950 / 750 (Heating)
	Evaporator	Number of rows	22
		Tube pitch row / pitch (in)	.69 / .50
		Fin spacing (in)	0.059
		Fin Type	Louvered Fin
		Tube outside dia.(in) / Type	0.2756 Rifled Tube
		Coil Length x height x width (in)	30.98 x 11.06 x 1
	Air Flow (Hi/Med/Low) (CFM)		459 / 406 / 218
	Noise Level (dB(A))		≤45
	Fan Type		Cross Flow
	Fan Diameter (in)		3.818
	Fan Length (in)		30.393
	Design Pressure (PSI)		551.14
	Unit Dimensions (W x H x D) (in)		36.61 x 10.83 x 8.27
	Packing Dimensions W x H x D) (in)		39.96 x 13.97 x 12.79
Net / Gross Wt (lbs)		30.86 / 37.48	
Dehumidifying Volume (pt/hr)		3.03	
Auto-restart		YES	

3. RATING CONDITIONS

Standard conditions in accordance with ANSI/AHAM RAC-1-2003, and UL 484.

Cooling:

Indoor: 80°F DB 67°F WB

Outdoor: 95°F DB 75°F WB

Heating:

Indoor: 70°F DB 60°F WB

Outdoor: 47°F DB 43°F WB

3.1 Operating Limits

		Outdoor
Cooling	Upper limit (DB)	110 °F
	Lower limit (DB)	5 °F
Heating	Upper limit (DB)	75 °F
	Lower limit (DB)	5 °F
Voltage	2PH	198–264V/115V
	3PH	N/A

4. OUTLINE DIMENSIONS

4.1 outdoor Unit: TAS-09EH/O

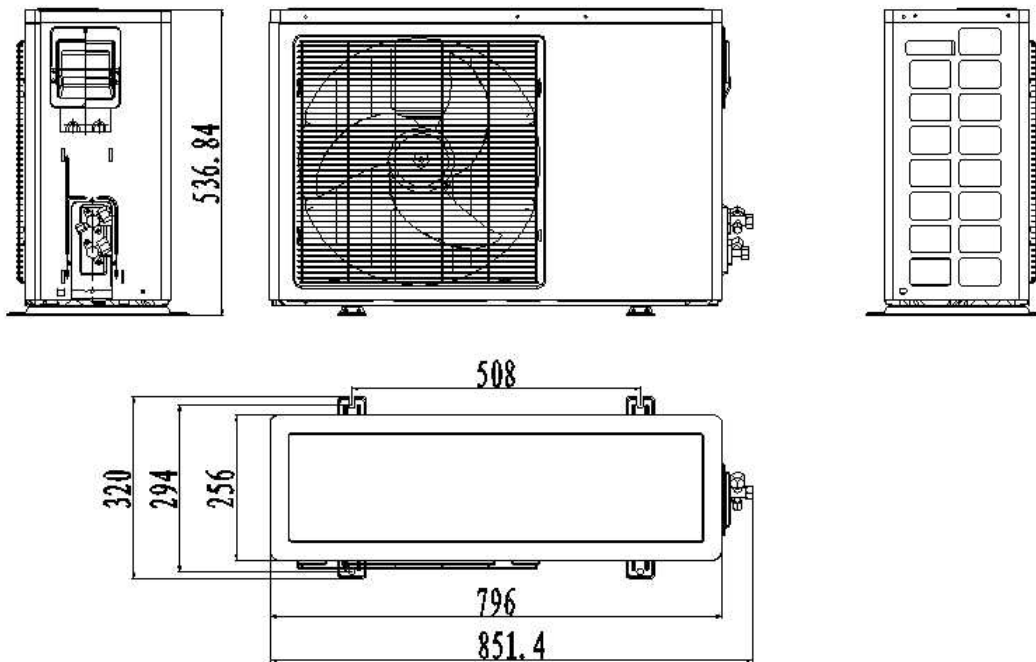

4.2 outdoor Unit: TAS-12EH/O

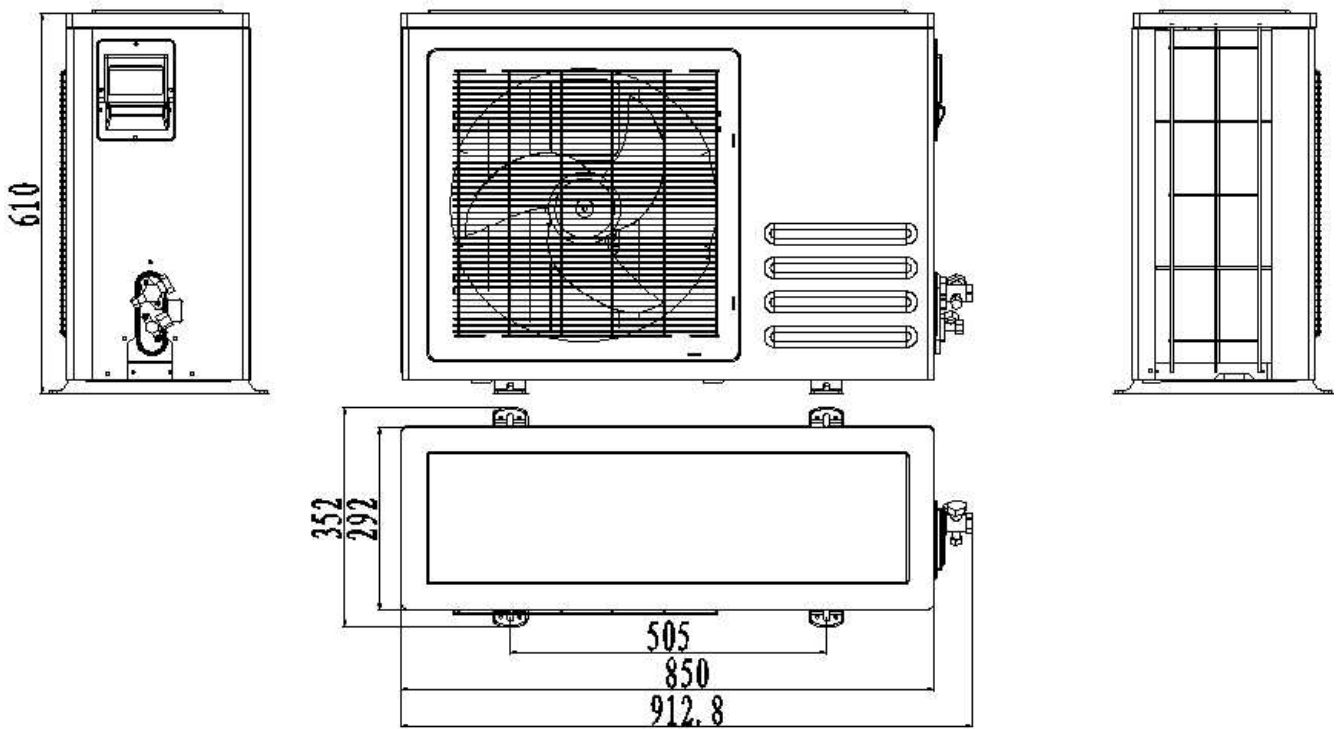

4.3 outdoor Unit: TAS-18VH/O

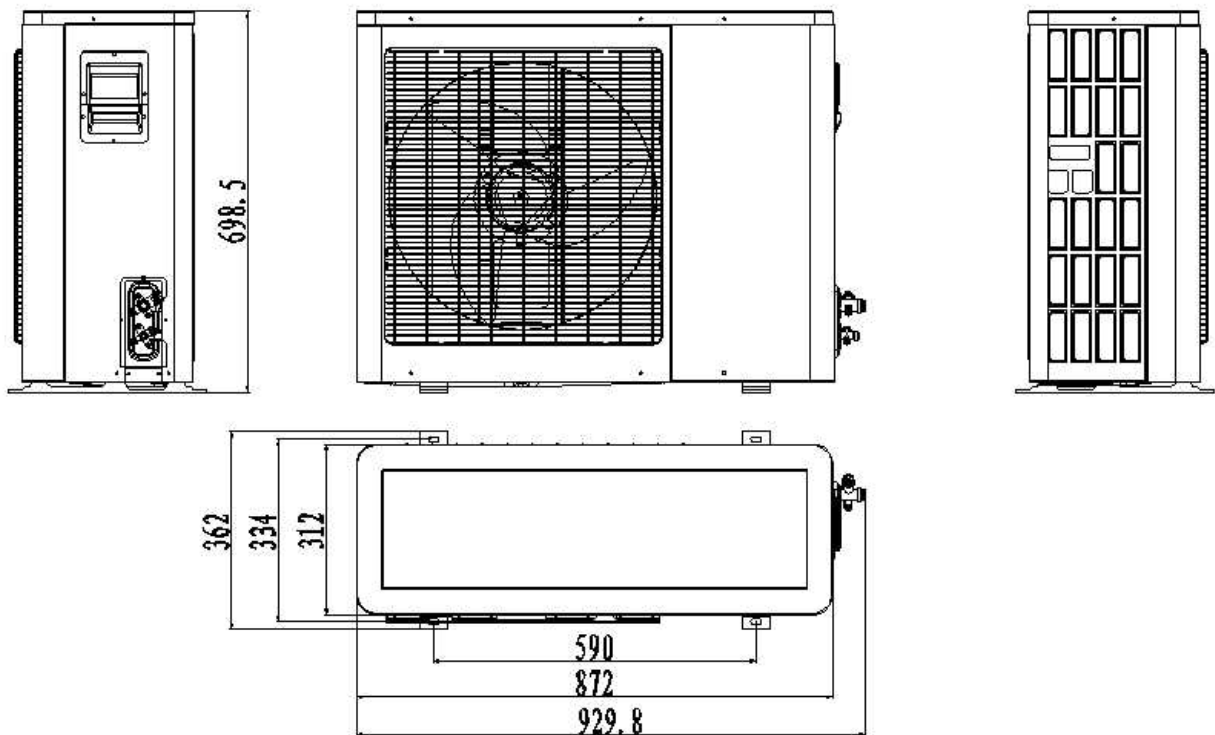

4.4 outdoor Unit: TAS-24VH/O

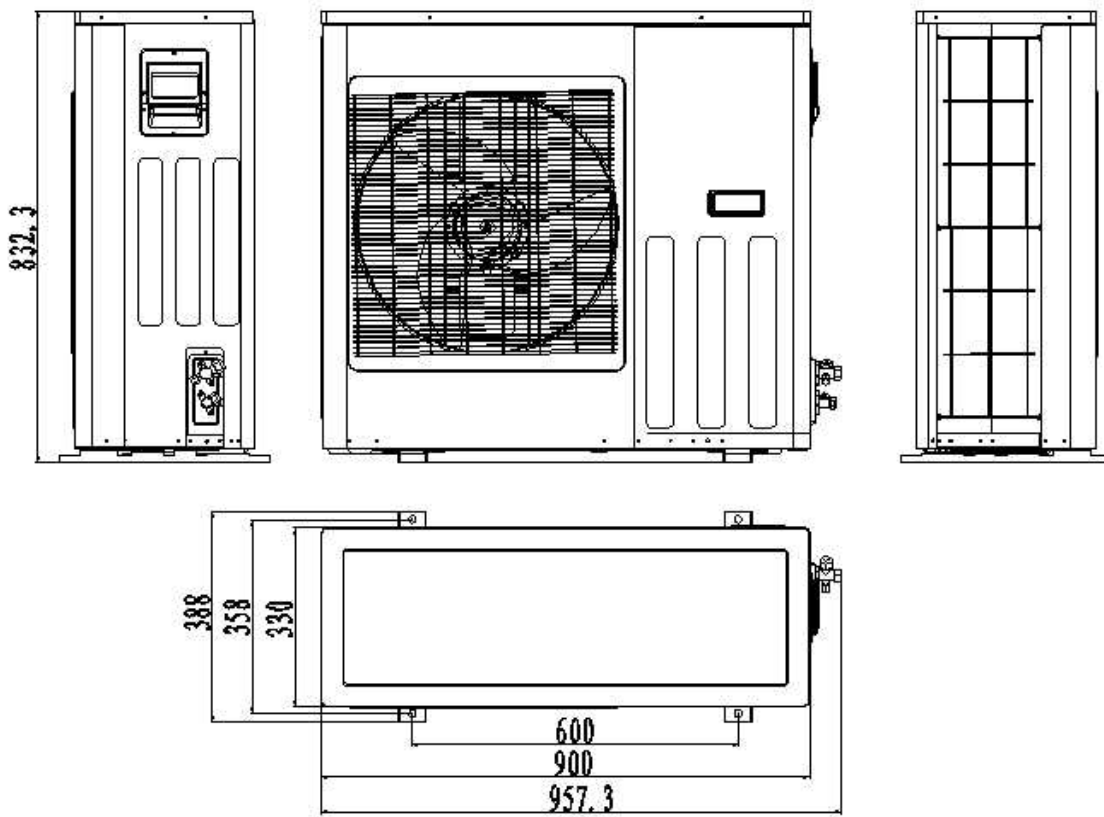

4.5 outdoor Unit: TAS-18MVH/O

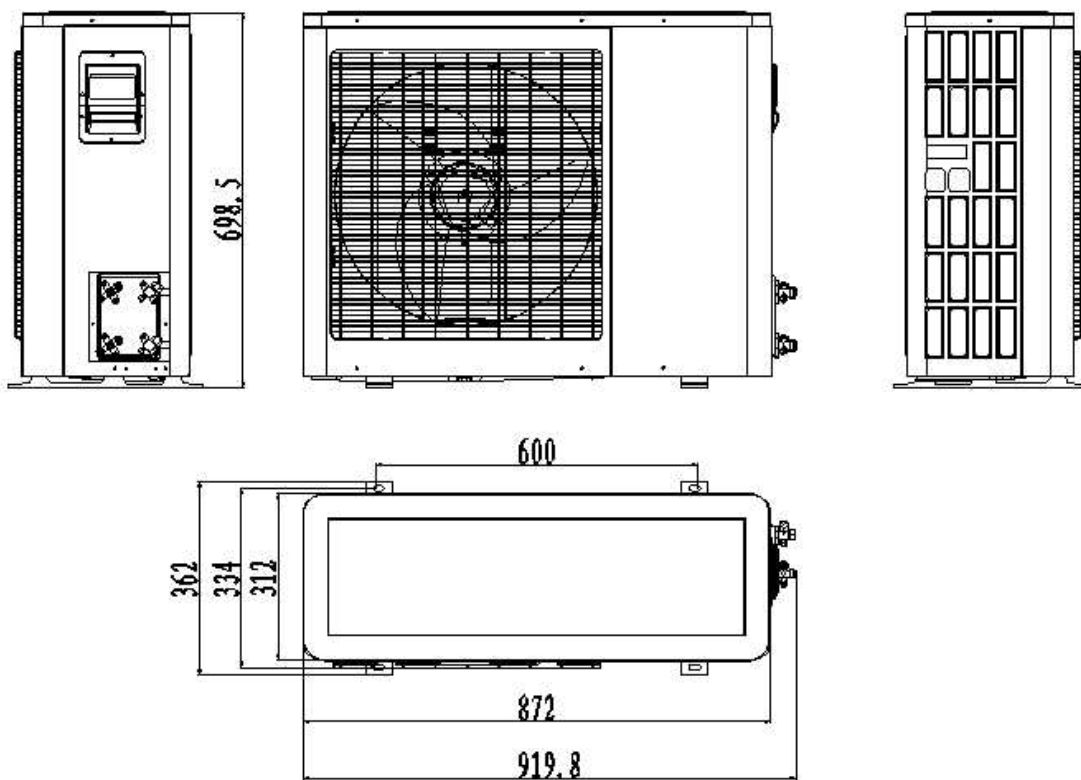

4.7 outdoor Unit: TAS-24MVH/O

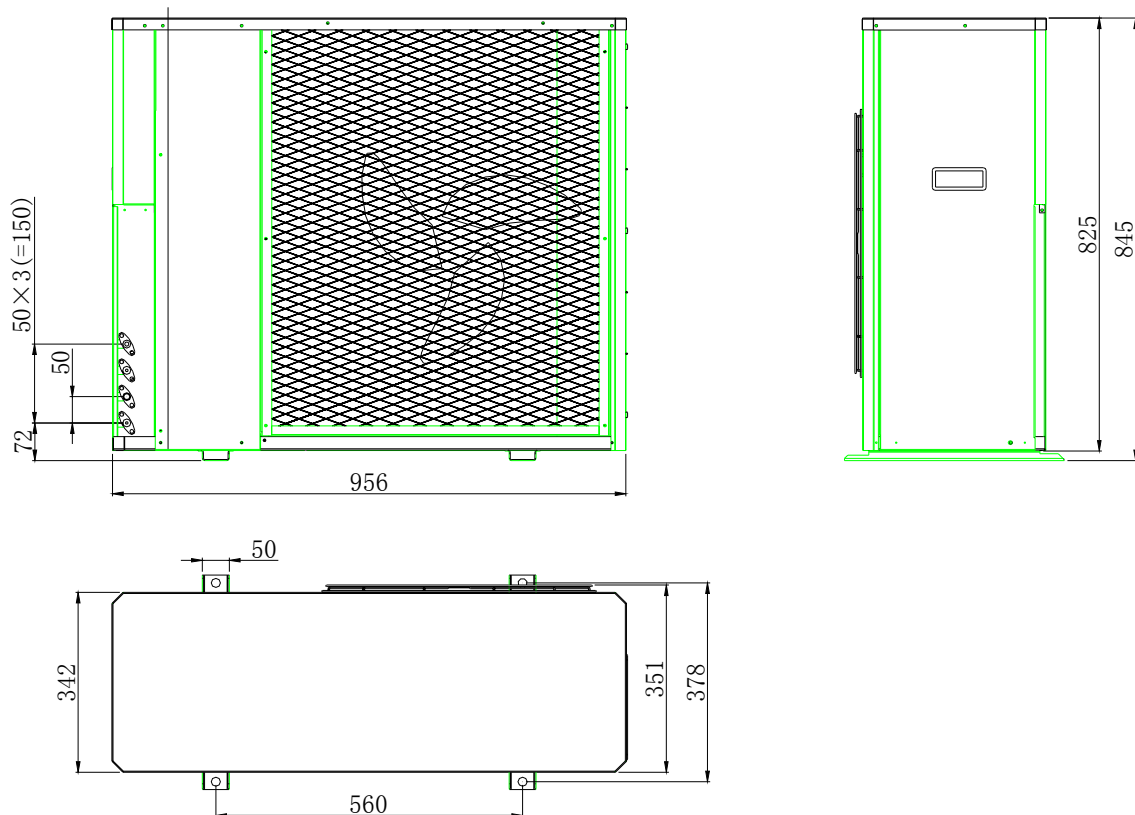

5. PERFORMANCE DATA

5.1 Indoor Units Data

5.1.1 Indoor Units Capacity For 9000BTU

Capacity	Model
9000BTU	TAS-09MVH
	TAS-09EH

5.1.1.1 Cooling Capacity (BTU)---Run Model (Unit A,B,C or D),230/115V,Indoor fan at high speed

INDOOR ENTERING AIR DB/WB TEMPERATURE [°F]						
OUTDOOR ENTERING AIR DB TEMPERATURE[°F]	DATA	72/59	75/63	81/66	84/70	90/73
14~68	TC	80 - 110 % of nominal				

(protection range)	SC	80 - 105 % of nominal				
	PI	25 - 50 % of nominal				
77	TC	8712	9252	9828	10404	10980
	SC	6273	6382	6528	6638	6784
	PI	0.58	0.59	0.6	0.61	0.62
86	TC	8280	8856	9432	9972	10548
	SC	6091	6236	6346	6492	6601
	PI	0.65	0.66	0.67	0.68	0.69
95	TC	7848	8424	9000	9576	10152
	SC	5945	6054	6200	6346	6455
	PI	0.71	0.72	0.74	0.75	0.76
104	TC	7452	8028	8568	9144	9720
	SC	5799	5908	6054	6164	6309
	PI	0.78	0.79	0.8	0.81	0.82
115	TC	6948	7524	8064	8640	9216
	SC	5580	5726	5835	5981	6091
	PI	0.86	0.87	0.88	0.89	0.91

LEGEND

TC – Total Cooling Capacity, BTU SC – Sensible Capacity, BTU PI – Power Input, kW
 WB – Wet Bulb Temp., (°F) DB – Dry Bulb Temp., (°F) ID – Indoor OD – Outdoor

5.1.1.2 Heating Capacity (BTU)---Run Model (Unit A,B,C or D),230/115V,Indoor fan at high speed

ID COIL ENTERING AIR DB TEMPERATURE [°F]				
OD COILENTERING AIR DB/WB TEM PERATU RE[°F]	DATA	59	68	77
5/3	TC	6912	6372	5940
	PI	0.49	0.54	0.59
14/10	TC	7668	7128	6696
	PI	0.59	0.64	0.70
20/18	TC	8208	7776	7236
	PI	0.67	0.72	0.77
30/28	TC	8532	8100	7560
	PI	0.71	0.75	0.80
36/34	TC	8748	8208	7776
	PI	0.89	0.95	1.01
45/43	TC	11232	10800	10368
	PI	0.77	0.82	0.87
50/48	TC	11880	11448	10908
	PI	0.82	0.87	0.92
59/54	TC	12528	12096	11556
	PI	0.86	0.90	0.96

59~75 (Protection Range)	TC	85 - 105 % of nominal
	PI	80 - 120 % of nominal

5.1.1.3 Capacity Correction Factors

Cooling Capacity Ratio Vs. Outdoor Temperature

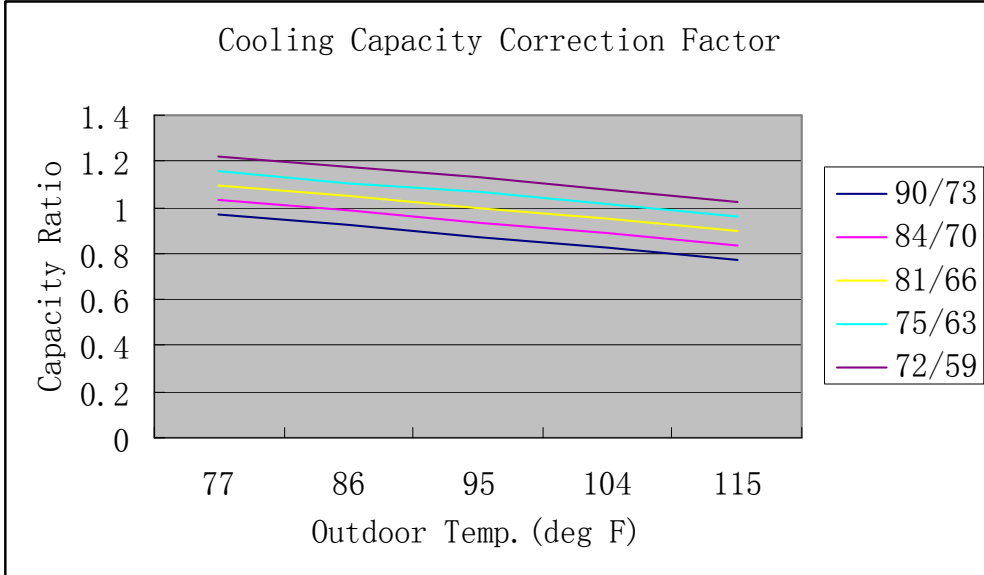

Heating Capacity Ratio Vs. Outdoor Temperature

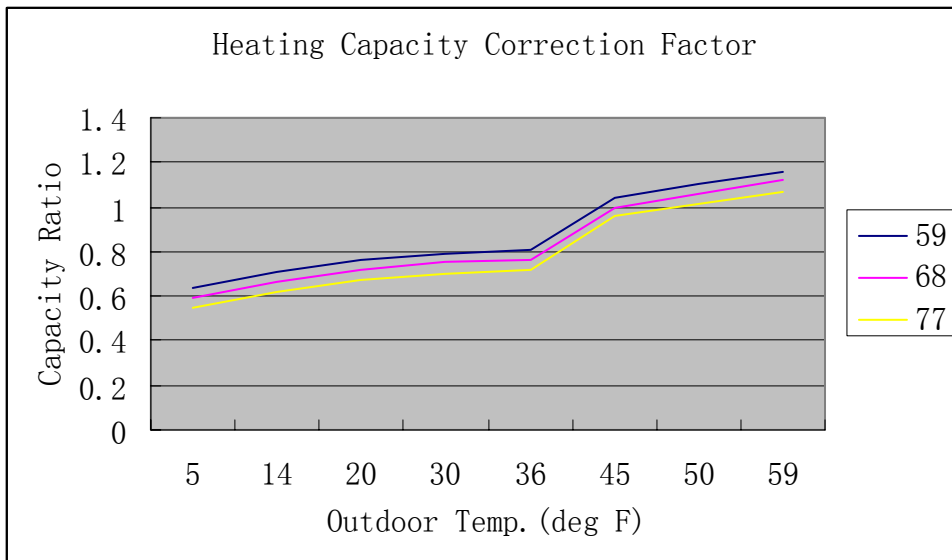

5.2.1 Indoor Units Capacity For 12000BTU

Capacity	Model
12000BTU	
	TAS-12MVH
	TAS-12EH

5.2.1.1 Cooling Capacity (BTU)---Run Model (Unit A,B,C or D),230/115V,Indoor fan at high speed

INDOOR ENTERING AIR DB/WB TEMPERATURE [°F]						
OUTDOOR ENTERING AIR DB TEMPERATURE[°F]	DATA	INDOOR ENTERING AIR DB/WB TEMPERATURE [°F]				
		72/59	75/63	81/66	84/70	90/73
14~68 (protection range)	TC	80 - 110 % of nominal				
	SC	80 - 105 % of nominal				
	PI	25 - 50 % of nominal				
77	TC	11616	12336	13104	13872	14640
	SC	10421	10603	10845	11027	11269
	PI	0.72	0.73	0.75	0.76	0.77
86	TC	11040	11808	12576	13296	14064
	SC	10118	10361	10542	10785	10966
	PI	0.81	0.82	0.83	0.85	0.86
95	TC	10464	11232	12000	12768	13536
	SC	9876	10058	10300	10542	10724
	PI	0.88	0.90	0.92	0.93	0.94
104	TC	9936	10704	11424	12192	12960
	SC	9634	9815	10058	10239	10482
	PI	0.97	0.98	0.99	1.01	1.02
115	TC	9264	10032	10752	11520	12288
	SC	9270	9512	9694	9936	10118
	PI	1.07	1.08	1.09	1.11	1.13

5.2.1.2 Heating Capacity (KW)---Run Model (Unit A,B,C or D),230V,Indoor fan at high speed

ID COIL ENTERING AIR DB TEMPERATURE [°F]				
OD COILENTERING AIR DB/WB TEM PERATU RE[°F]	DATA	59	68	77
5/3	TC	8960	8260	7700
	PI	0.66	0.73	0.80
14/10	TC	9940	9240	8680
	PI	0.80	0.87	0.95
20/18	TC	10640	10080	9380
	PI	0.91	0.97	1.04
30/28	TC	11060	10500	9800
	PI	0.96	1.02	1.08
36/34	TC	11340	10640	10080
	PI	0.99	1.06	1.12
45/43	TC	14560	14000	13440
	PI	1.04	1.11	1.18
50/48	TC	15400	14840	14140
	PI	1.11	1.18	1.25
59/54	TC	16240	15680	14980
	PI	1.16	1.22	1.30
59~75 (Protection Range)	TC	85 - 105 % of nominal		
	PI	80 - 120 % of nominal		

5.2.1.3 Capacity Correction Factors

Cooling Capacity Ratio Vs. Outdoor Temperature

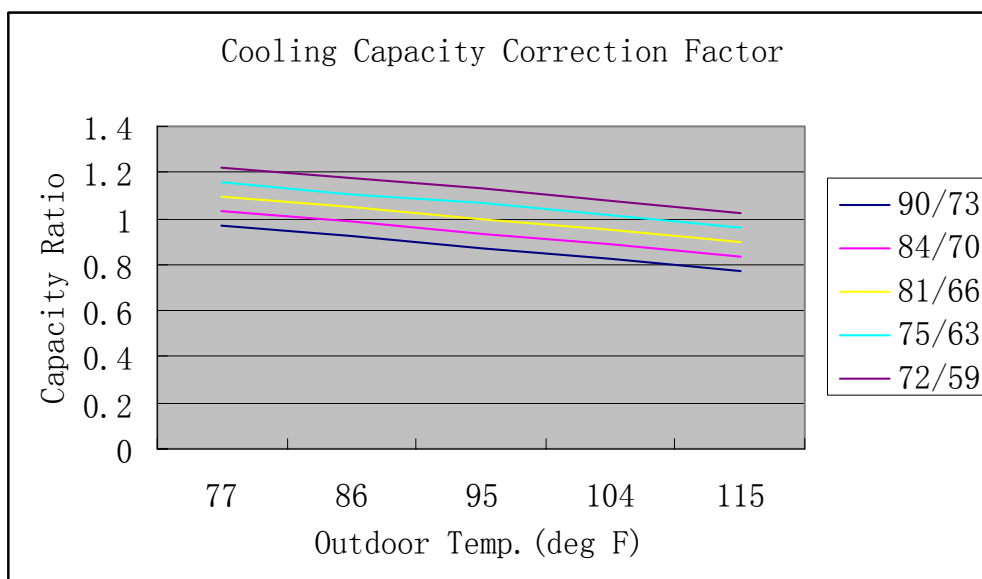

Heating Capacity Ratio Vs. Outdoor Temperature

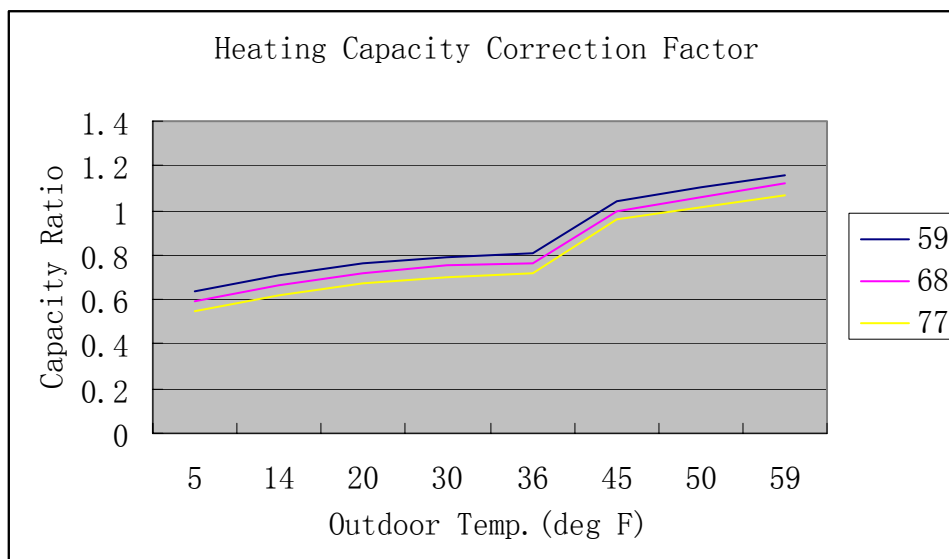

5.2.3 Indoor Units Capacity For 18000BTU

Capacity	Model
18000BTU	TAS-18EH

5.2.3.1 Cooling Capacity (BTU)---Run Model ,230V,Indoor fan at high speed

INDOOR ENTERING AIR DB/WB TEMPERATURE [°F]						
OUTDOOR ENTERING AIR DB TEMPERATURE[0F]	DATA	72/59	75/63	81/66	84/70	90/73
14~68 (protection range)	TC	80 - 110 % of nominal				
	SC	80 - 105 % of nominal				
	PI	25 - 50 % of nominal				
77	TC	17424	18504	19656	20808	21960
	SC	15480	15750	16110	16380	16740
	PI	1.19	1.21	1.23	1.25	1.27
86	TC	16560	17712	18864	19944	21096
	SC	15030	15390	15660	16020	16290
	PI	1.34	1.36	1.38	1.40	1.42
95	TC	15696	16848	18000	19152	20304
	SC	14670	14940	15300	15660	15930
	PI	1.46	1.48	1.52	1.54	1.56
104	TC	14904	16056	17136	18288	19440
	SC	14310	14580	14940	15210	15570
	PI	1.60	1.62	1.64	1.66	1.68
115	TC	13896	15048	16128	17280	18432
	SC	13770	14130	14400	14760	15030
	PI	1.77	1.79	1.81	1.83	1.87

5.2.3.2 Heating Capacity (BTU)---Run Model,230V,Indoor fan at high speed

ID COIL ENTERING AIR DB TEMPERATURE [°F]				
OD COILENTERING AIR DB/WB TEM PERATU RE[°F]	DATA	59	68	77
5/3	TC	12160	11210	10450
	PI	0.96	1.05	1.15
14/10	TC	13490	12540	11780
	PI	1.15	1.25	1.37
20/18	TC	14440	13680	12730
	PI	1.31	1.40	1.50
30/28	TC	15010	14250	13300
	PI	1.39	1.46	1.56
36/34	TC	15390	14440	13680
	PI	1.42	1.52	1.62
45/43	TC	19760	19000	18240
	PI	1.50	1.60	1.70
50/48	TC	20900	20140	19190
	PI	1.60	1.70	1.80
59/54	TC	22040	21280	20330
	PI	1.68	1.76	1.87
59~75 (Protection Range)	TC	85 - 105 % of nominal		
	PI	80 - 120 % of nominal		

5.2.3.3 Capacity Correction Factors

Cooling Capacity Ratio Vs. Outdoor Temperature

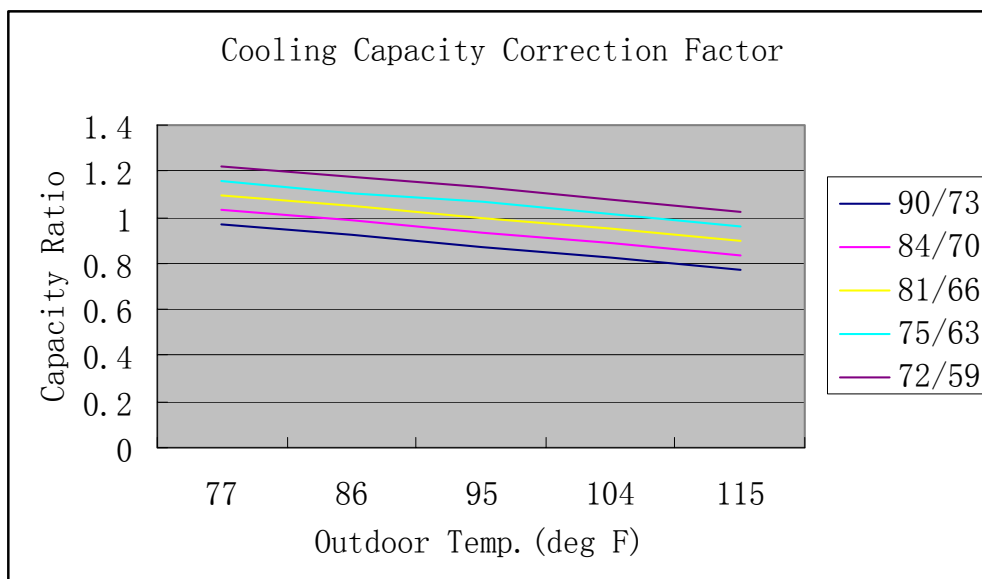

Heating Capacity Ratio Vs. Outdoor Temperature

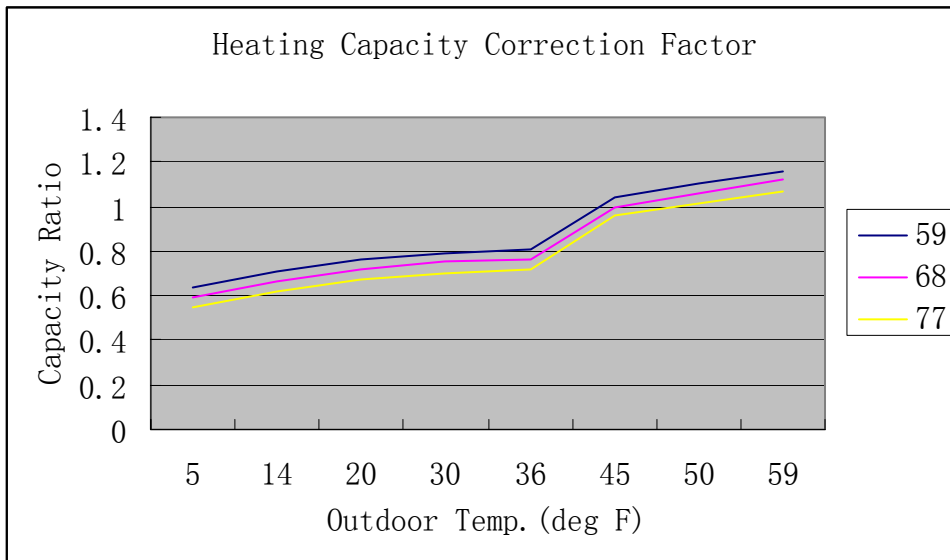

5.2.4 Indoor Units Capacity For 24000BTU

Capacity	Model
24000BTU	TAS-24EH

5.2.4.1 Cooling Capacity (BTU)---Run Model,230V,Indoor fan at high speed

INDOOR ENTERING AIR DB/WB TEMPERATURE [°F]						
OUTDOOR ENTERING AIR DB TEMPERATURE [°F]	DATA	72/59	75/63	81/66	84/70	90/73
14~68 (protection range)	TC	80 - 110 % of nominal				
	SC	80 - 105 % of nominal				
	PI	25 - 50 % of nominal				
77	TC	23232	24672	26208	27744	29280
	SC	20640	21000	21480	21840	22320
	PI	1.72	1.75	1.78	1.81	1.84
86	TC	22080	23616	25152	26592	28128
	SC	20040	20520	20880	21360	21720
	PI	1.93	1.96	1.99	2.02	2.05
95	TC	20928	22464	24000	25536	27072
	SC	19560	19920	20400	20880	21240
	PI	2.11	2.14	2.20	2.23	2.26
104	TC	19872	21408	22848	24384	25920
	SC	19080	19440	19920	20280	20760
	PI	2.32	2.35	2.38	2.41	2.44
115	TC	18528	20064	21504	23040	24576
	SC	18360	18840	19200	19680	20040
	PI	2.56	2.59	2.62	2.65	2.71

5.2.4.2 Heating Capacity (BTU)---Run Model,230V,Indoor fan at high speed

ID COIL ENTERING AIR DB TEMPERATURE [°F]				
OD COILENTERING AIR DB/WB TEM PERATURE [°F]	DATA	59	68	77
5/3	TC	15680	14455	13475
	PI	1.35	1.49	1.63
14/10	TC	17395	16170	15190
	PI	1.63	1.76	1.93
20/18	TC	18620	17640	16415
	PI	1.85	1.98	2.12
30/28	TC	19355	18375	17150
	PI	1.96	2.07	2.20
36/34	TC	19845	18620	17640
	PI	2.01	2.15	2.29
45/43	TC	25480	24500	23520
	PI	2.12	2.26	2.40
50/48	TC	26950	25970	24745
	PI	2.26	2.40	2.54
59/54	TC	28420	27440	26215
	PI	2.37	2.48	2.65
59~75 (Protection Range)	TC	85 - 105 % of nominal		
	PI	80 - 120 % of nominal		

5.2.4.3 Capacity Correction Factors

Cooling Capacity Ratio Vs. Outdoor Temperature

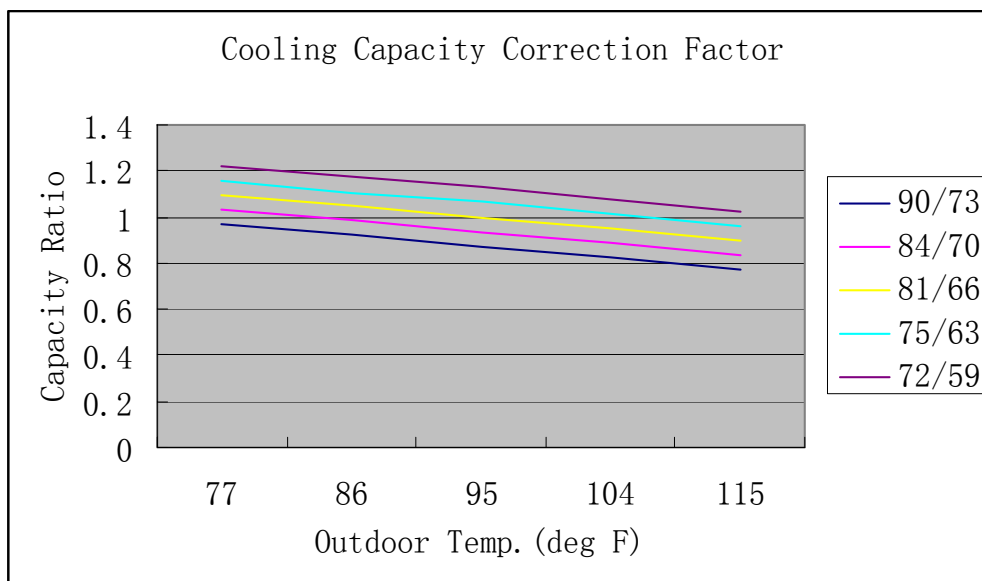

Heating Capacity Ratio Vs. Outdoor Temperature

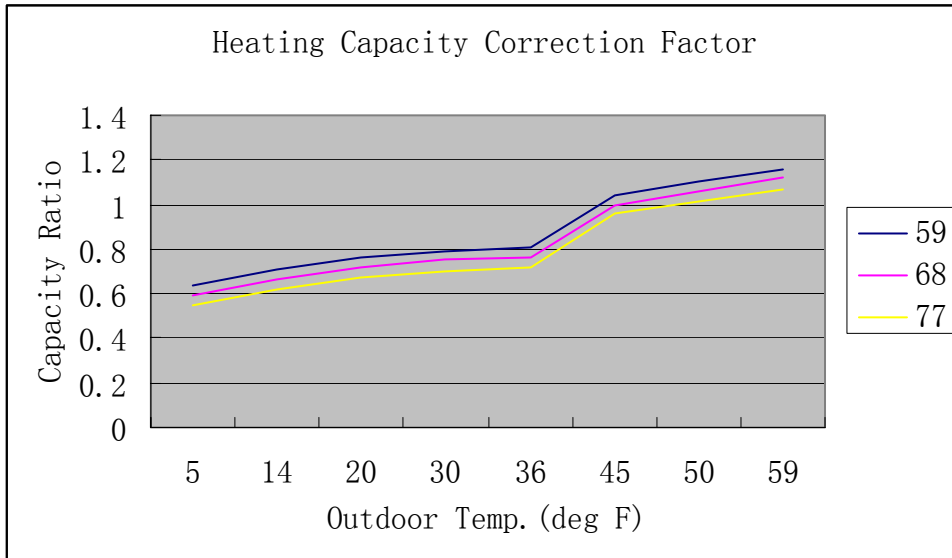

5.3 Capacity Correction Factor Due to Tubing Length (One Way)

5.3.1 Indoor units Model

TAS-09MVH	TAS-12MVH
TAS-09EH	TAS-12EH
TAS-18EH	TAS-24EH

5.3.1.1 Cooling

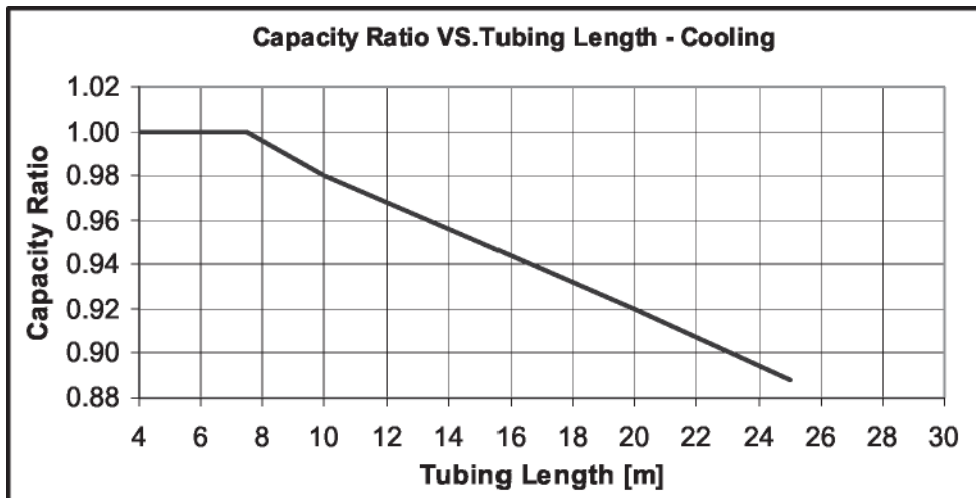

5.3.1.2 Heating

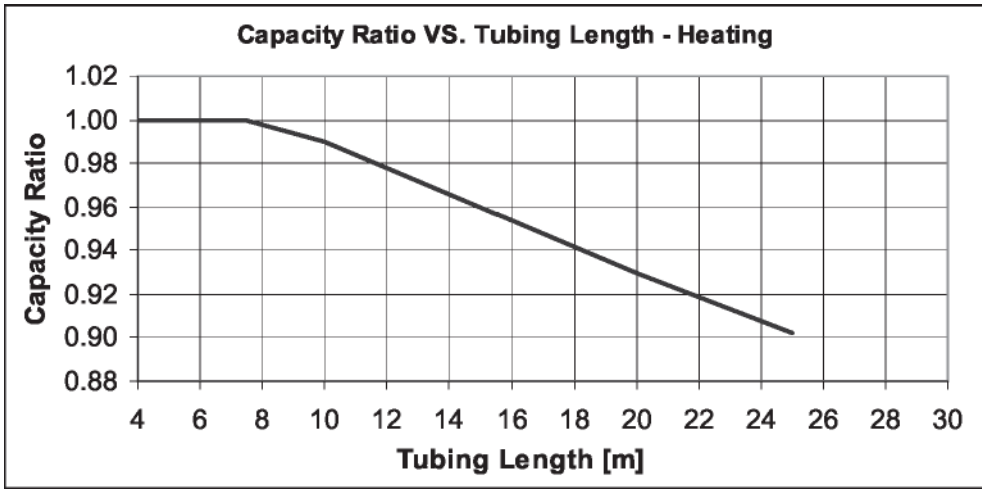

6. Pressure Curve

6.1 Model

TAS-09EH/0	TAS-18MVH/0
TAS-12EH/0	TAS-24MVH/0
TAS-18EH/0	
TAS-24EH/0	

6.1.1 Suction Pressure Curve

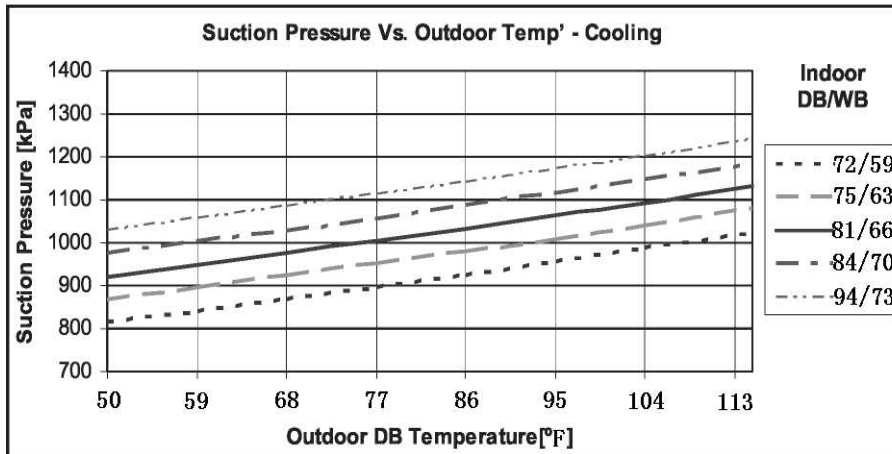

6.1.2 Discharge Pressure Curve

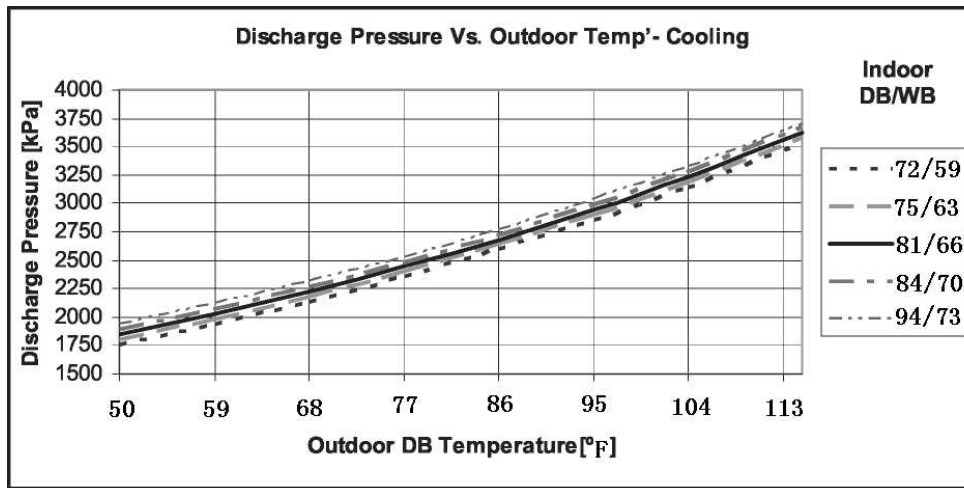

7. ELECTRICAL DATA

Model	TAS-09EH/O
Power Supply	1 PH, 115 VAC,60Hz
Connected to	Outdoor
Maximum Current	9.3A
Inrush Current	40A
Starting Current	1A
Circuit breaker	30A
Power supply wiring - No. x cross section	1 X 3 X 2.5 mm ²
Interconnecting cable - No. x cross section	2 X 4 X 1 mm ²

Model	TAS-12EH/O
Power Supply	1 PH, 115 VAC,60Hz
Connected to	Outdoor
Maximum Current	10.8A
Inrush Current	40A
Starting Current	1A
Circuit breaker	30A
Power supply wiring - No. x cross section	1 X 3 X 2.5 mm ²
Interconnecting cable - No. x cross section	2 X 4 X 1 mm ²

Model	TAS-18EH/O
Power Supply	1 PH, 230 VAC,60Hz
Connected to	Outdoor
Maximum Current	10.1A
Inrush Current	40A
Starting Current	1A
Circuit breaker	30A

Power supply wiring - No. x cross section	1 X 3 X 2.5 mm ²
Interconnecting cable - No. x cross section	2 X 4 X 1 mm ²

Model	TAS-24EH/O
Power Supply	1 PH, 230 VAC,60Hz
Connected to	Outdoor
Maximum Current	12.2A
Inrush Current	35A
Starting Current	1A
Circuit breaker	30A
Power supply wiring - No. x cross section	1 X 3 X 2.5 mm ²
Interconnecting cable - No. x cross section	2 X 4 X 1 mm ²

Model	TAS-18MVH/O
Power Supply	1 PH, 230 VAC,60Hz
Connected to	Outdoor
Maximum Current	10.5A
Inrush Current	40A
Starting Current	1A
Circuit breaker	20A
Power supply wiring - No. x cross section	1 X 3 X 2.5 mm ²
Interconnecting cable - No. x cross section	2 X 4 X 1 mm ²

Model	TAS-24MVH/O
Power Supply	1 PH, 230 VAC,60Hz
Connected to	Outdoor
Maximum Current	13A
Inrush Current	35A
Starting Current	1A
Circuit breaker	30A
Power supply wiring - No. x cross section	1 X 3 X 2.5 mm ²
Interconnecting cable - No. x cross section	2 X 4 X 1 mm ²

Note:

Inrush current is the current when power is up. (charging the DC capacitors at outdoor unit controller).

Starting current is the current when starting the compressor

NOTE

Power wiring cord should comply with local laws and electrical regulations requirements.

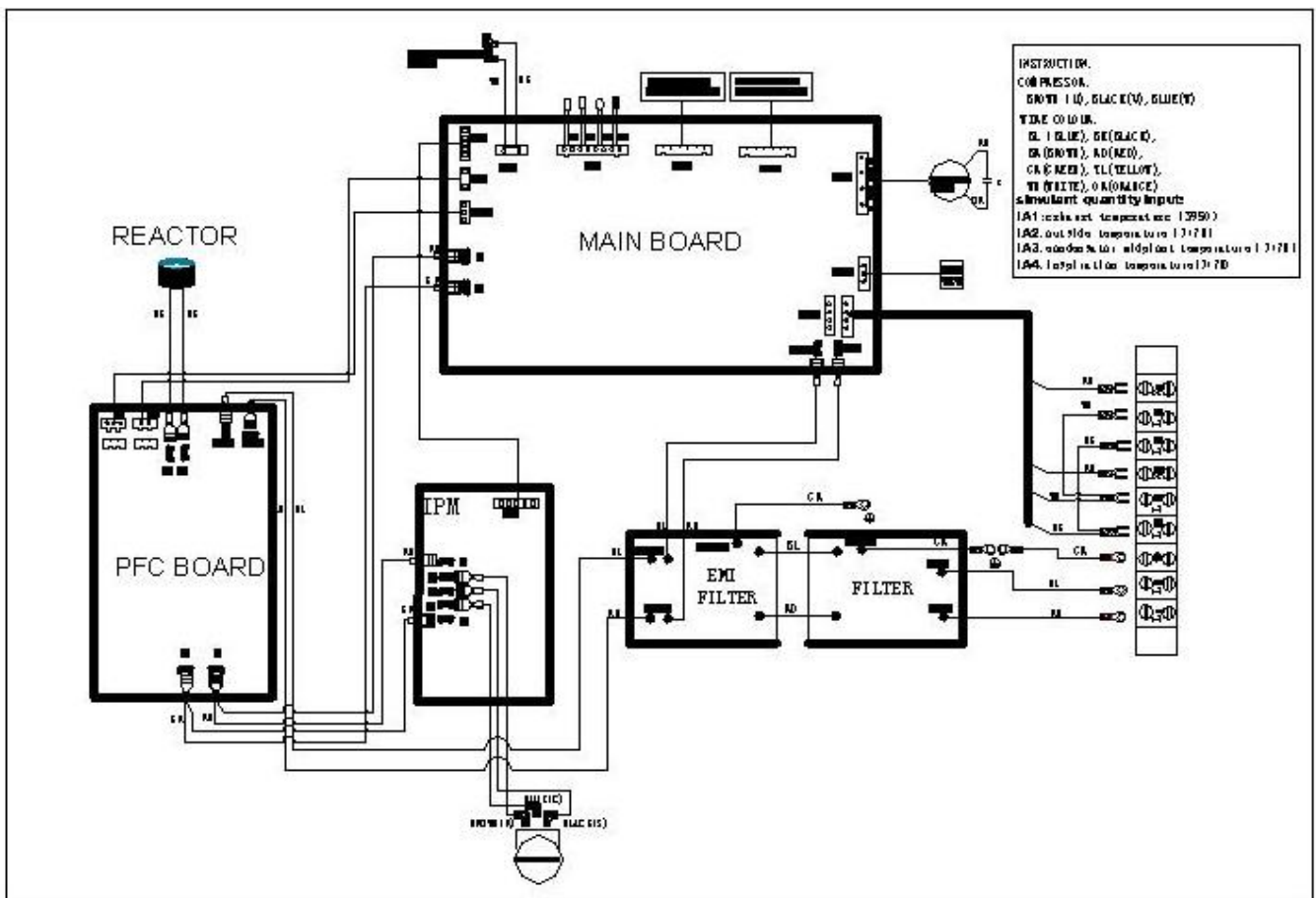

8.6 TAS-24MVH/O Wiring Diagram

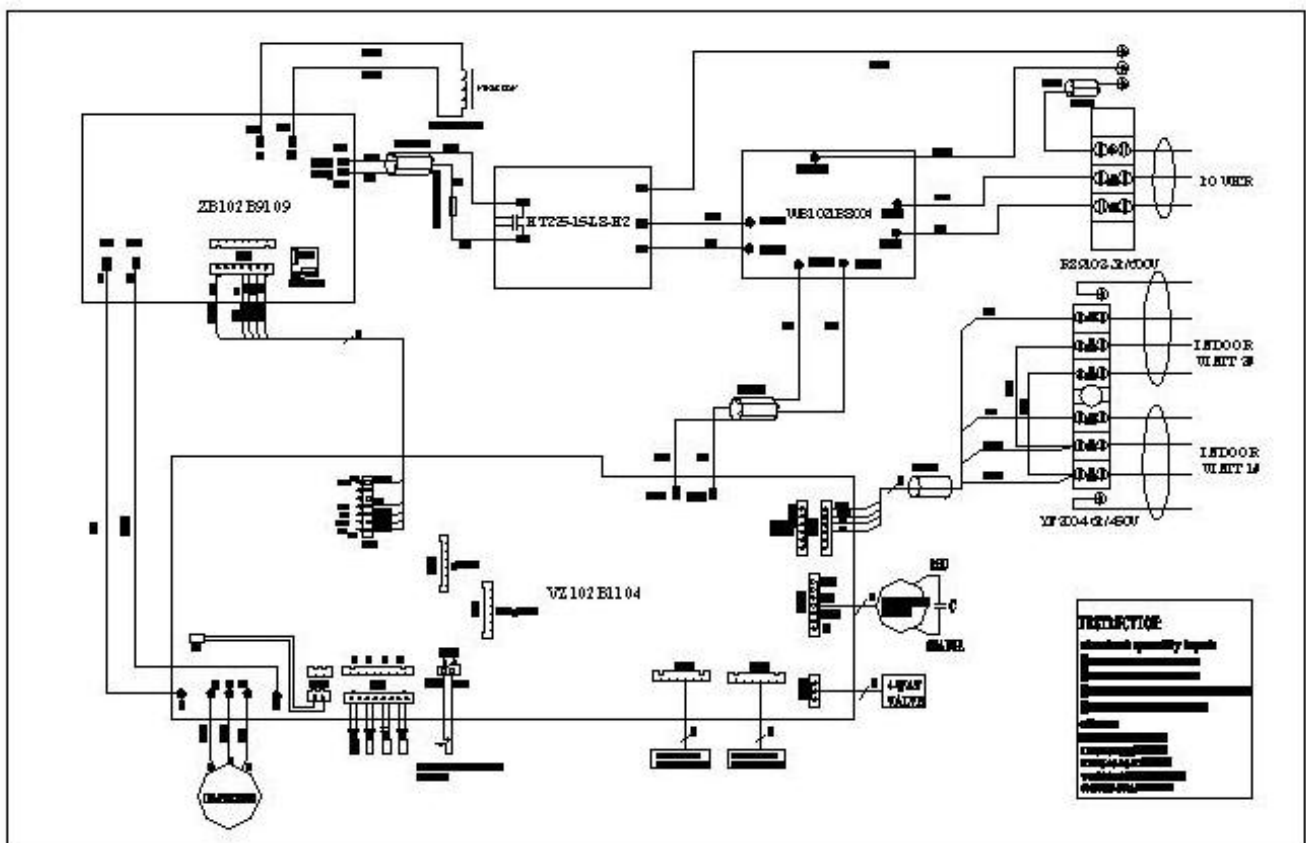

8.4 TAS-18MVH/O TAS-24MVH/O Indoor-Outdoor Wiring Diagram

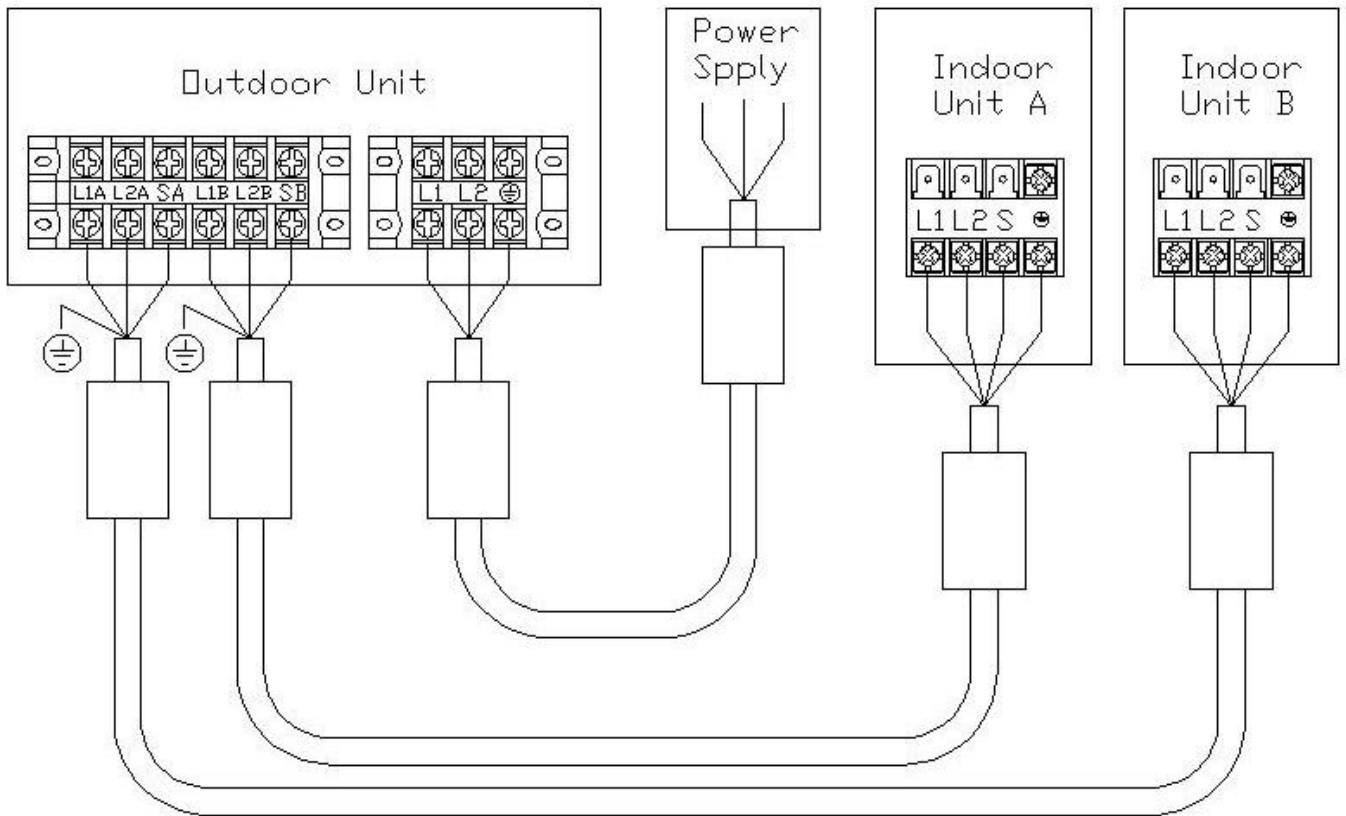

**8.5 TAS-09EH/O TAS-12EH/O TAS-18EH/O TAS-24EH/O
Indoor-Outdoor Wiring Diagram**

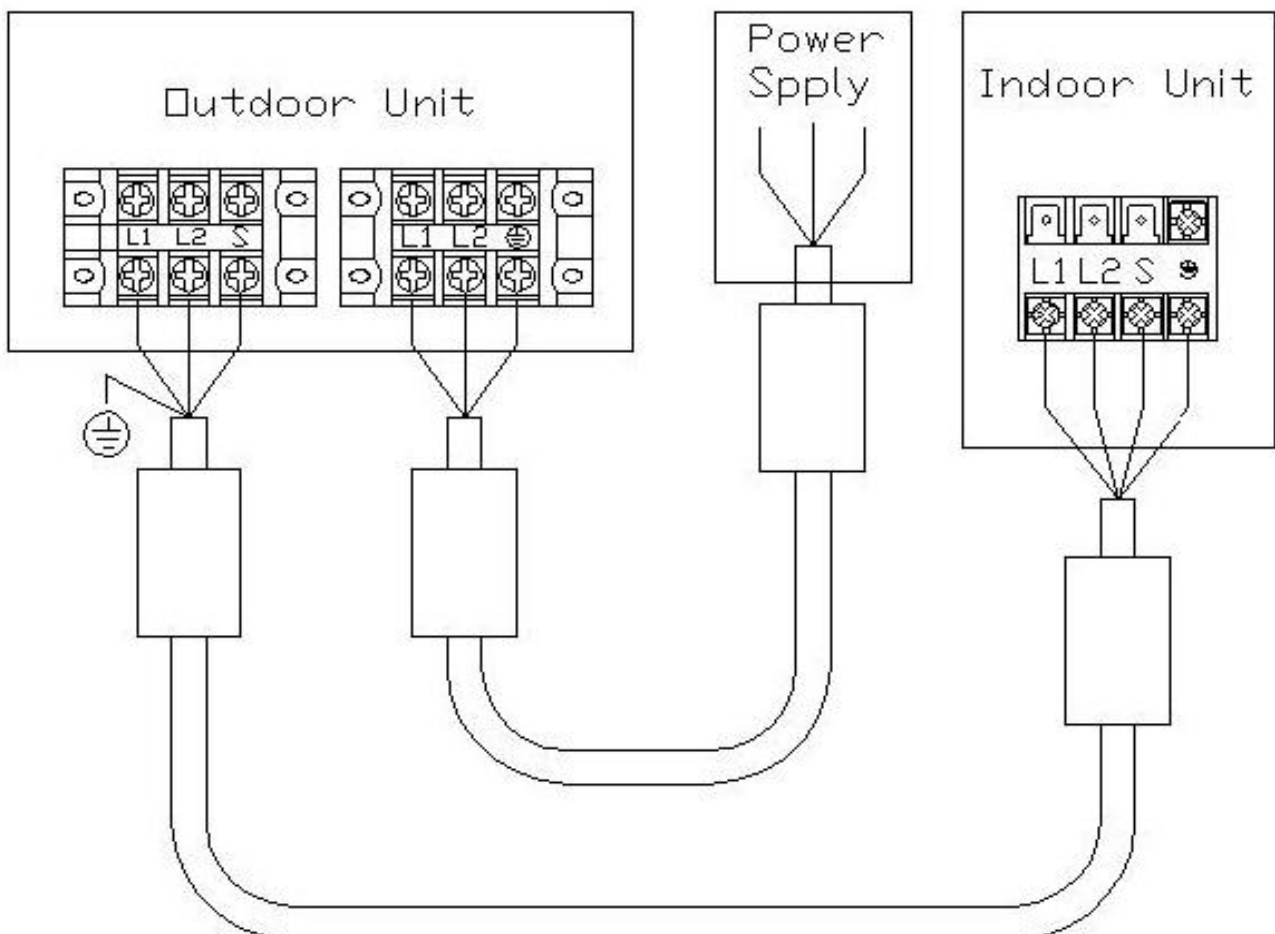

9. REFRIGERATION DIAGRAMS

9.1 TAS-09EH/O Refrigeration Diagram

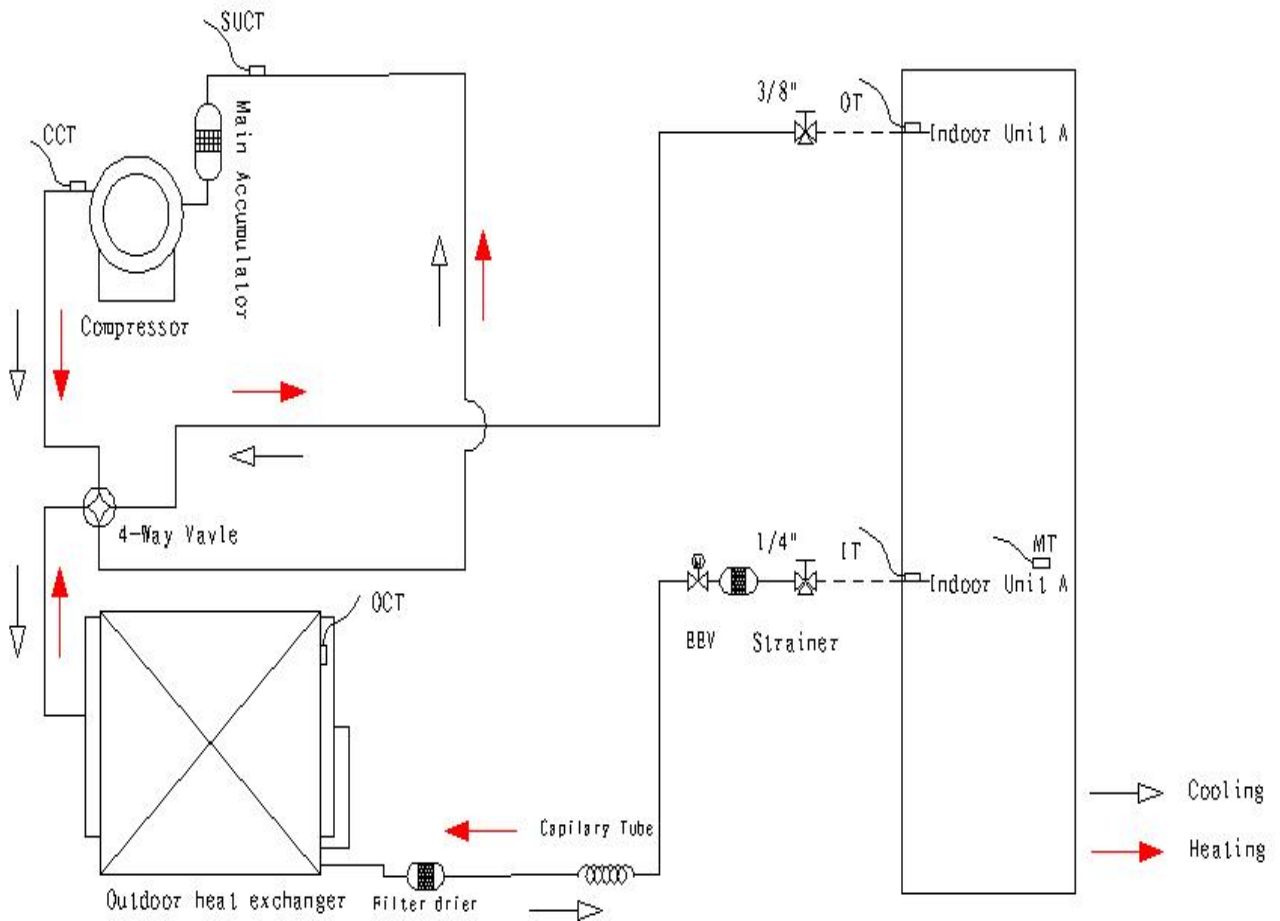

9.2 TAS-12EH/O Refrigeration Diagram

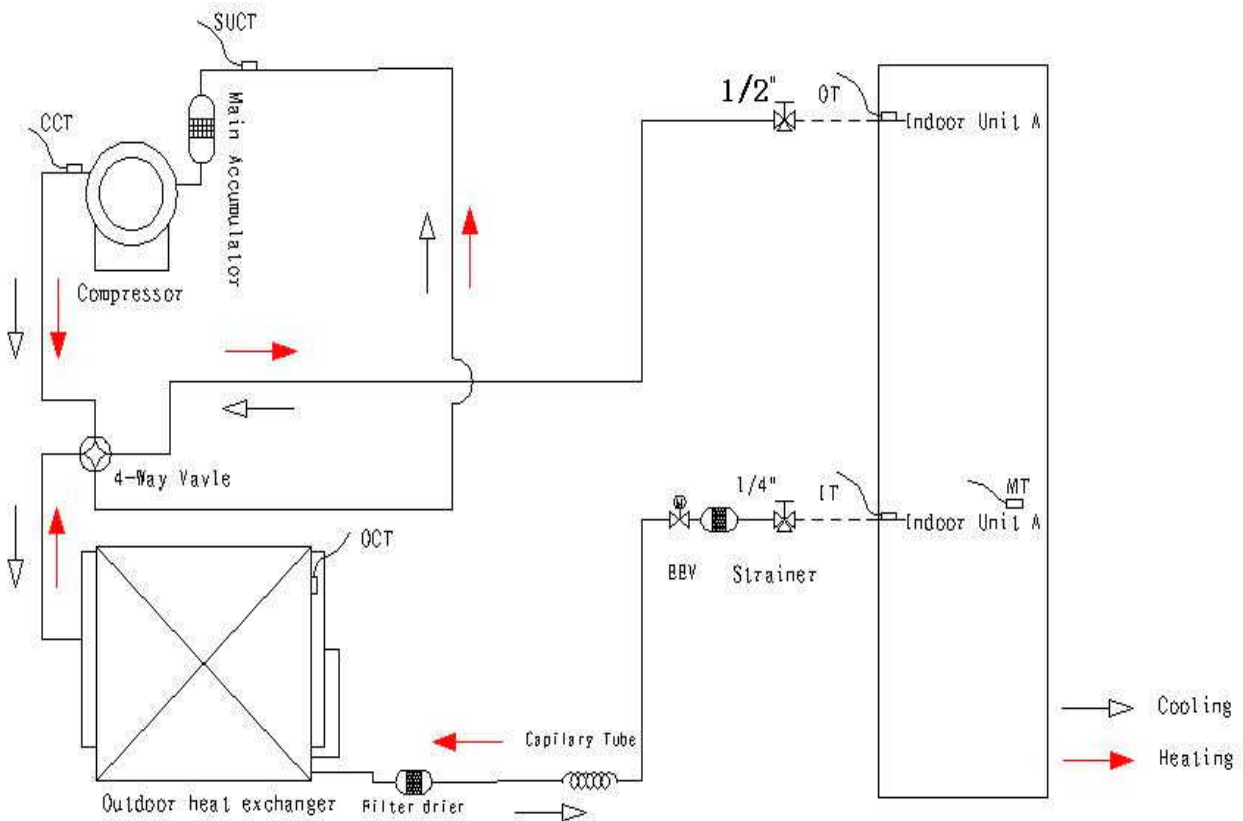

9.3 TAS-18VH/O TAS-24EH/O Refrigeration Diagram

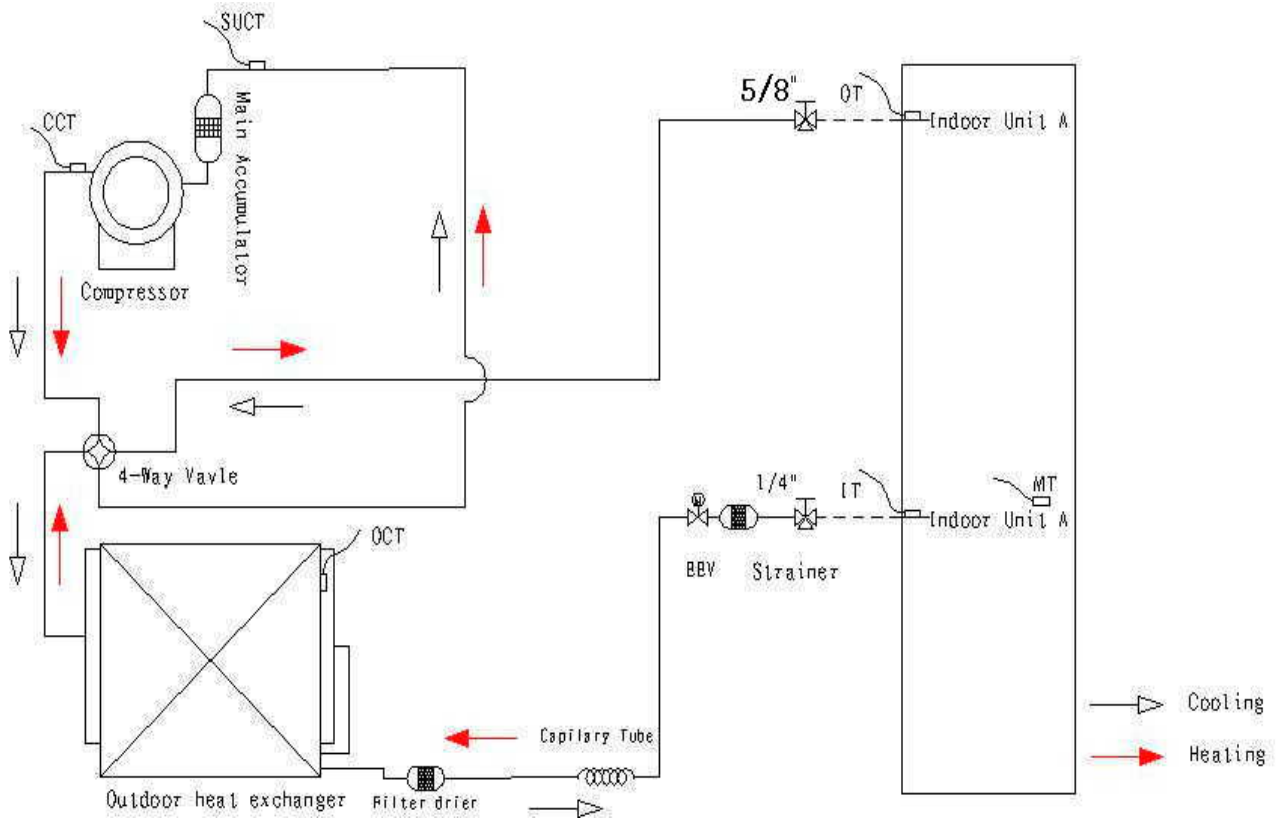

9.4 TAS-18MVH/O Refrigeration Diagram

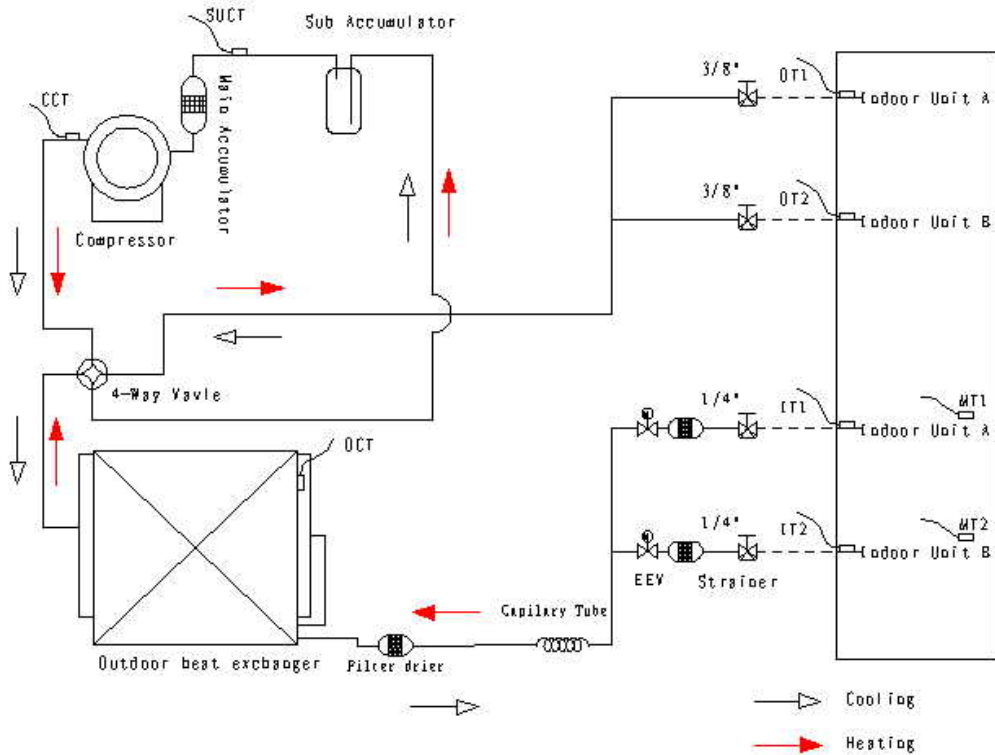

9.5 TAS-24MVH/O Refrigeration Diagram

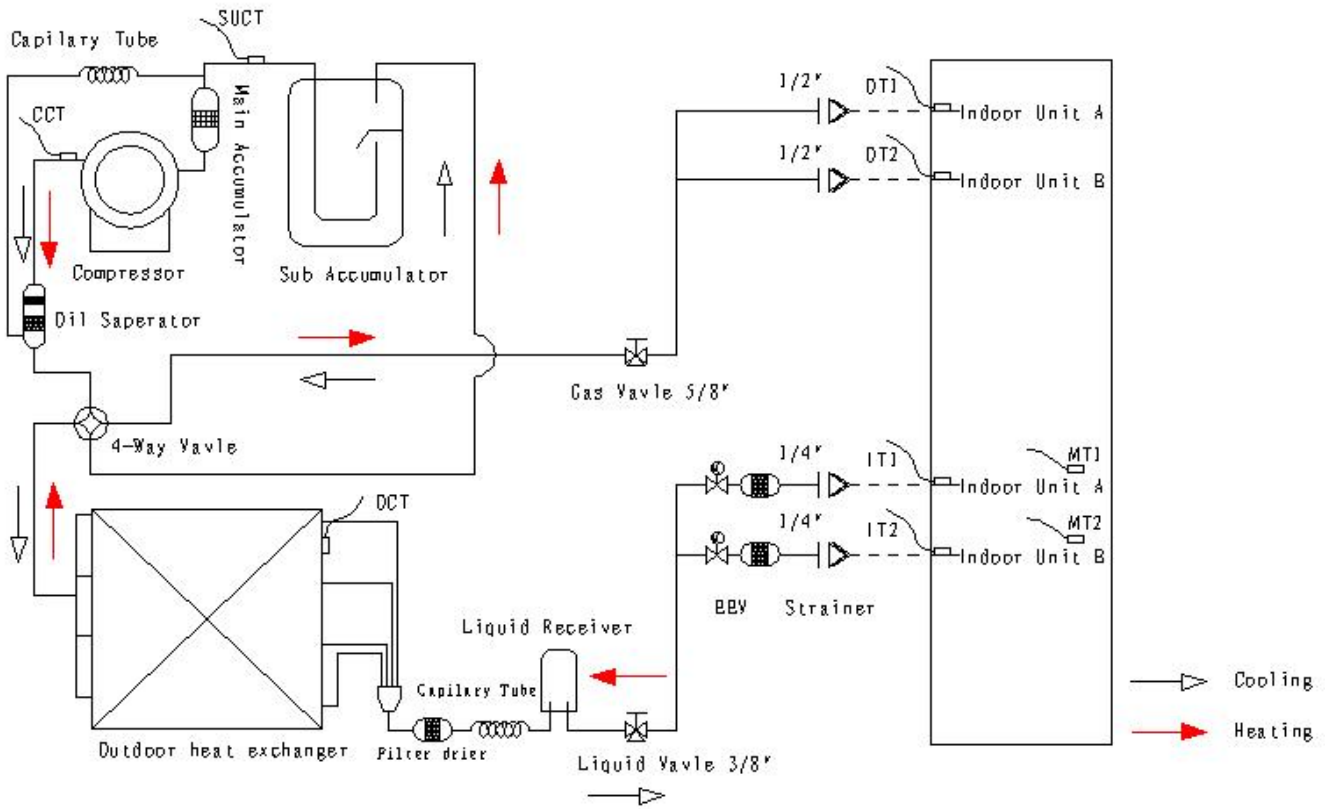

10. TUBING CONNECTIONS

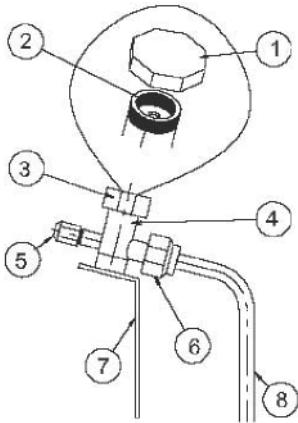
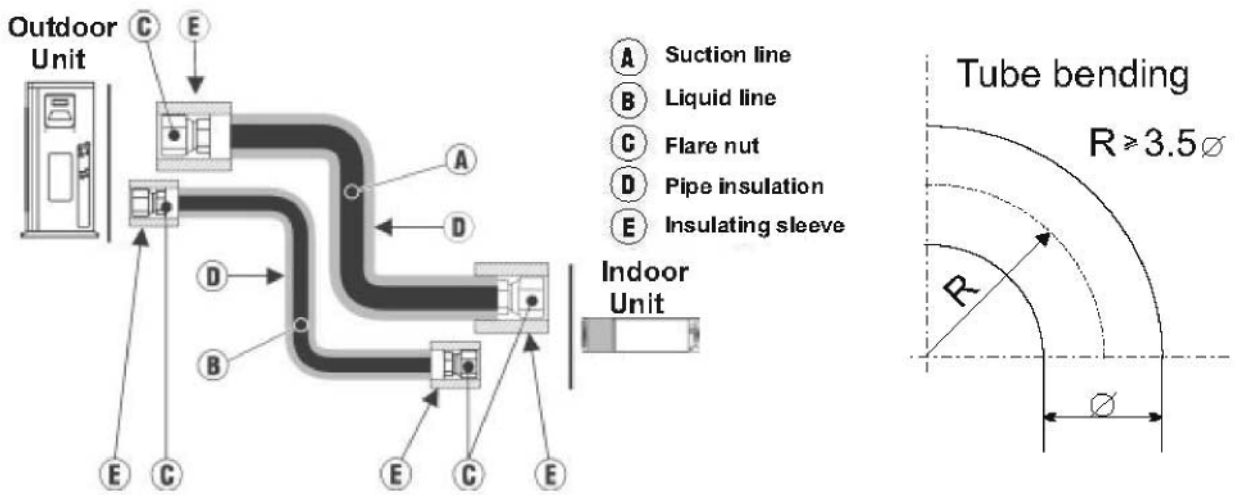

TUBE (Inch)	1/4"	~"	1/2"	~"	3/4"
TORQUE (Nm)					
Flare Nuts	11-13	40-45	60-65	70-75	80-85
Valve Cap	13-20	13-20	18-25	18-25	40-50
Service Port Cap	11-13	11-13	11-13	11-13	11-13

1. Valve Protection Cap-end
2. Refrigerant Valve Port (use Allen wrench to open/close)
3. Valve Protection Cap
4. Refrigerant Valve
5. Service Port Cap
6. Flare Nut
7. Unit Back Side
8. Copper Tube

When the outdoor unit is installed above the indoor unit an oil trap is required every 5m along the suction line at the lowest point of the riser. In case the indoor unit is installed above the outdoor, no trap is required

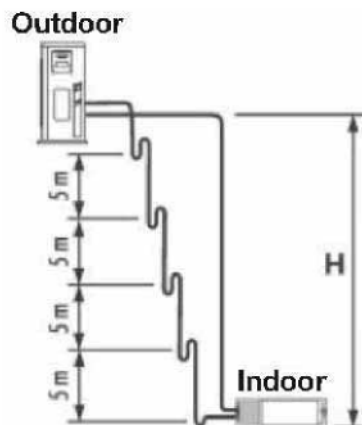

11. CONTROL SYSTEM

Function of Inverter indoor unit

一、summary

1. This control is use for DC Multi-Split air conditioners.
2. Power of indoor unit supply is 220-240V/50Hz, voltage range is 170V~270V.
3. Control precision of indoor temperature is $\pm 1.8^{\circ}\text{F}$.
4. Indoor fan motor is PG motor.
5. Control accord with :
 - GB5956-91 《safe requirement of air conditioner》
 - GB7725-2004《air conditioner》; GB3797-87《control equipment of electrical equipment》
 - Vibrancy test: frequency 50Hz, acceleration 2.5g
 - PCB ought to accord with GB4588.1 and GB4588.2
 - Electromagnetism compatibility ought to accord with relate standard of nation.

二. Base parameter

1. Use condition: ambient temperature $5^{\circ}\text{F}\sim 185^{\circ}\text{F}$, relative humidity =30-95%.
2. Receive distance of remote:<10m
3. Angle of remote:<120 degree
4. Control precision of temperature: $\pm 1.8^{\circ}\text{F}$
5. Speed precision of indoor fan motor: $\pm 10\text{RPM}$
6. Time precision: <0.1%

三. Major function of control

1. Remote

- Turn on/off
- Mode select
 - ◇ auto
 - ◇ cooling
 - ◇ dehumidify
 - ◇ heating
 - ◇ ventilation
- Indoor fan speed select
 - ◇ manual mode: high, middle, low speed
 - ◇ auto mode: accord difference of indoor room temp. and set temp. automatic select.
- Temperature setting
 - ◇ Cooling: $60^{\circ}\text{F}\sim 90^{\circ}\text{F}$, default is 77°F
 - ◇ Heating : $60^{\circ}\text{F}\sim 90^{\circ}\text{F}$, default is 77°F
 - ◇ Dehumidify: default is 77°F and it can' t adjust.
 - ◇ Auto: default is 77°F and it can' t adjust.
 - ◇ Ventilation: $60^{\circ}\text{F}\sim 90^{\circ}\text{F}$, default is 77°F
- Sleeping
 - ◇It can set or cancel 24HR sleep .
- Timer on or timer off
 - ◇ Timer can set 24HR on or off.
- Air flower control.
- Turbo running
- Hold key

2. Main PCB board

- five running modes
 - ✧Auto, cooling, heating, dehumidify, ventilation.
 - Timer function
 - Indoor temperature detect.
 - Indoor coil temperature detect.
- Indoor fan speed control
 - ✧cooling: turbo/high speed/middle speed/low speed/ lower speed
 - ✧heating: turbo/high speed/middle speed/low speed/ lower speed
- Indicate lamp
 - ✧ green—running indicate
 - ✧ yellow—timer indicate
 - ✧ red—turbo running
 - ✧ green—economic running
- Indoor temperature control
- Coil pipe of indoor unit overheat protection
- Coil pipe of indoor unit anti frost protection
- Sleep
- Swing
- Anti cold air in heating mode
- Indoor fan motor protection
- Fault display

DC Inverter 1:1

24000BTU:

mode	high	middle	low
Cooling speed	1280	1180	1080
Heating speed	1280	1180	1080

18000BTU:

mode	high	middle	low
Cooling speed	1230	1000	950
Heating speed	1230	1000	950

12000BTU:

mode	high	middle	low
Cooling speed	1000	900	750
Heating speed	1000	900	750

9000BTU:

mode	high	middle	low
Cooling	1300	1150	950

speed			
Heating speed	1300	1150	950

DC Inverter 1:2

PG motor speed:

12000BTU:

mode	higher	high	middle	low	lower
Cooling speed	1250	1200	950	850	850
Heating speed	1250	1200	950	850	750

9000BTU:

mode	higher	high	middle	low	lower
Cooling speed	1250	1150	950	750	750
Heating speed	1250	1150	950	750	750

四、operating mode

Air conditioner have four operating mode: auto, cooling, dehumidify, heating.

1. Cooling ($\Delta T = T_{\text{room temp.}} - T_{\text{set temp.}}$)

- range of set temp. 60°F~90°F;
- compressor running as below figure:

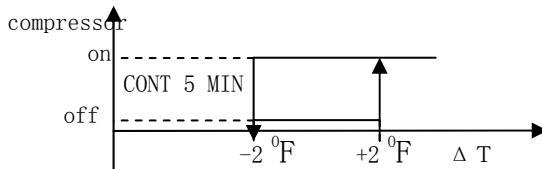

- ✧ It require outdoor unit to reduce power if indoor room temp. continuous less than set temp. for 5 minutes.
- ✧ Air blow function: indoor blower fan continuous running 20 seconds at low speed after air conditioner turn off in cooling mode. if the flap is swing, shutdown the flap after turn off indoor blower fan.
- ✧ Indoor blower fan can select one of four speed.
- Fan speed is determined by the difference of room temp. and set temp. in auto wind.

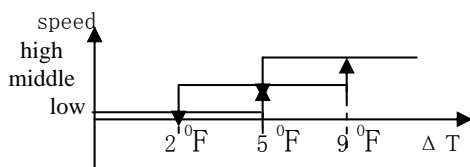

- It have anti freeze protection of indoor coil , fan motor fault protection, sensor fault protection, unit abnormal protection in cooling mode.

2. Dehumidify: ($\Delta T = T_{\text{room temp.}} - T_{\text{set temp.}}$)

- range of set temp.: default is 77°F and it can't change.
- The indoor blower fan is running at low speed for thirty seconds after air conditioner shutdown in dehumidify mode.

- The indoor blower fan is running at low speed and it can't change.
- Air conditioner haven't turbo and economic function in dehumidify mode.
 - Flap position: flap at 85 degree position and it can't change.
- It require indoor unit to reduce power if indoor room temp. continuous less than or equal to 15 degree for 5 minutes, when room temp. is more than or equal to 17 degree, it add the power of indoor unit.

3. Heating ($\Delta T = T_{\text{room temp.}} - T_{\text{set temp.}}$)

- Range of set temp. 60 °F~90 °F;
- Compressor running as below figure.

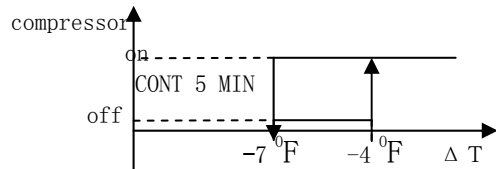

- ✧ It require outdoor unit to reduce power if indoor room temp. continuous more than set temp. for 5 minutes.
- ✧ Indoor blower fan continuous running for 30 seconds at current speed after indoor unit reduce power.
 - Indoor blower fan can select one of four speed.
 - Fan speed is determined by the difference of room temp. and set temp. in auto wind. (but anti cold wind is prior)

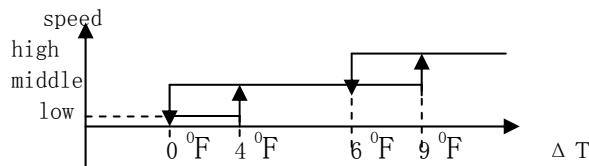

- Anti cold wind:
 - ✧ When air conditioner first power on or change mode, indoor blower fan didn't running. When the coil pipe temp. of indoor unit is more than 86 °F, start turning on indoor blower fan(lower speed).if the coil pipe temp. of indoor unit drop to less than or equal to 77 °F, it shutdown indoor blower fan.

✧ Heat wind control:

If coil pipe temp. of indoor unit is more than or equal to 90 °F, indoor blower fan is running at set speed.

If coil pipe temp. of indoor unit is less than 90 °F, indoor blower fan is running as below figure.

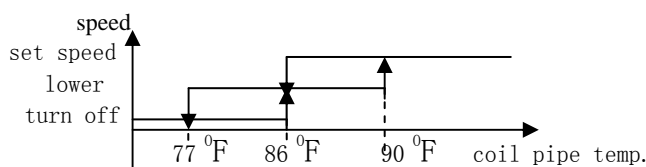

Note: ①When $T_p \leq 86$ °F, flap is open at 85° and is running at lower speed, when $T_p \geq 90$ °F, it is running at set speed and flap revert to prior state.

②If $T_p \leq 77$ °F, turn off indoor blower fan.

- Defrost control
 - ✧Indoor blower fan turn off when it enter defrost.
- Clear quantity of heat

- ✧ Turn off air conditioner in heating mode, if the coil pipe temp. of indoor unit is more than 104°F, indoor blower fan is running at low speed. If the coil pipe temp. of indoor unit is less than or equal to 104°F or turn off air conditioner over 2 minutes, It shutdown indoor blower fan.

4. Auto mode

- set temp. is 77°F and it can't change;
- Press emergency key in waiting state or select auto mode by remote, air conditioner enter auto mode and set temp. is 77°F.
- Indoor blower fan is running for 20 seconds at lower speed after select auto mode, the running lamp is light, it select correspond running mode accord to room temp. :
 room temp. >79°F, select cooling mode.
 room temp. <70°F, select heating mode.
 70°F ≤ room temp. ≤ 79°F, select ventilation mode.
 When the running mode has confirmed, it can't change, if it reenter auto mode, it select running mode again accord to room temp..
- When the mode of auto select is clash with other indoor unit running mode:
- ✧ If it auto select is cooling mode and other indoor unit is running heating mode, then it select ventilation mode.
- ✧ If it auto select is heating mode, but other indoor unit is running cooling mode, display error of mode clash.
- ✧ if it select is ventilation mode, then it running is ventilation.

5. Ventilation

- 1) Range of set temp. : 60°F -90°F.
- 2) Indoor blower fan is operate same as cooling mode.
- 3) Flap is operate same as cooling mode.
- 4) Indoor unit no power require in ventilation mode.

6. Timer and sleep

- timer
- ✧ Remote can set 1-24 hours timer on or timer off.
- ✧ Air conditioner is running .
 If set timer off, air conditioner is continuous running and display timer time, when timer time is end, it shutdown air conditioner.
- ✧ air conditioner is shutdown .
 If set timer on, air conditioner at waiting state, it display timer time. when timer time is end, it turn on air conditioner.
- ✧ when it set timer , the timer lamp is light and display set temp.
- sleep
- ✧ If set sleep, the sleep lamp is light, set temp. and fan speed can be adjust.
- ✧ Timer and sleep can set together, which time is end then perform this function.

7. Air flow control

Define: flap full open angle is 0° , and full close angle is 125° .

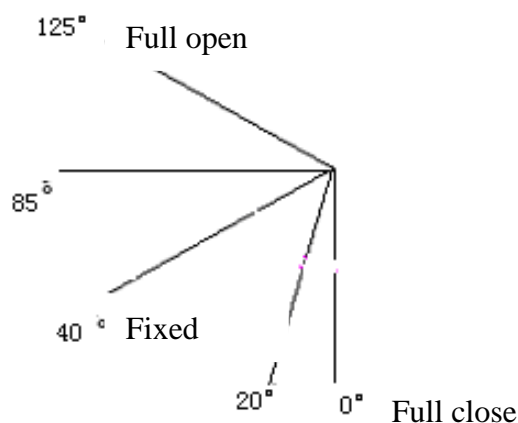

- Power on, flap run to full close position.
- Turn off air conditioner, flap run to full close position.
- Turn on air conditioner, flap first run to full open position, then run to correspond position.
- Fixed wind:
 - ✧ If turn on air conditioner and set fixed wind at first power on, flap first run to full open position then stop at 40° position.
 - ✧ If change to fixed wind from swing wind or natural wind, the flap stop at current position and store the position.
- Swing wind:
 - ✧ Flap start position is 20° .
 - ✧ Flap is running between 20° and 85° .
 - Natural wind is swing two cycle and stop 15 seconds, flap is stop at current position at that moment.
 - Flap stop at 85° at anti cold wind or defrost procedure in heating mode.
 - Flap stop at 85° in first 20 seconds of auto mode.
 - Flap is drive by step motor.

8. Turbo function

Turbo is use in cooling /heating/ventilation mode, the indoor blower fan is running at super speed.

- (1) enter condition: press turbo key of remote.
- (2) end condition:
 - ① running time more than or equal to 15 minutes.
 - ② press turbo key of remote again.
- (3) all restrict and protect condition are active in turbo running.
- (4) return to prior state after end turbo running.

五、Protection

1. Prevent frost of indoor coil pipe (cooling and dehumidify mode)

- ✧ When the temp. of middle coil pipe is less than or equal to 32°F, indoor blower fan is running at high speed, if the temp. less than or equal to 30°F for 5 minutes, it turn off compressor, when the temp. more than or equal to 45°F, it exit protection.

2. Overheat of indoor coil pipe(heating mode)

- ✧ When the temp. of middle coil pipe more than or equal to 135°F, indoor blower fan is running at high speed, if the temp. more than or equal to 149°F, it turn off outdoor unit, when the temp. less than or equal to 129°F, it exit protection.

3. Indoor fan motor fault(only PG motor)

✧ If no feedback signal continuous 30 seconds during PG motor running, it turn off air conditioner and display fan motor error.

4. Communicate fault

✧ If it can't receive correct signals after air conditioner has run for 60 seconds, it turn off air conditioner and display communicate error.

5. Indoor sensor fault

✧ When indoor sensor cut off or short, it shutdown air conditioner and display sensor error.

6. When outdoor unit is fault, indoor unit only display fault.

六、 Other function

Emergency key

Press emergency key after power on, air conditioner select auto mode, auto fan speed, natural wind, it set temp. is 77 °F. If press emergency key again, air conditioner is shutdown.

七、 Sound indication

1. The buzzer will sound when air conditioner turn on , turn off, power on or receive remote signal.

八、 Display

1. After turn on air conditioner, mode clash display **d1** and timer lamp flash (light one second, extinguish one second), defrost display **dF**, the running lamp flash (light one second, extinguish one second) indicate anti cold wind ,when air conditioner is normal running , the running lamp is light.

2. Set timer or sleep , the yellow lamp is light.

3. Outdoor unit and indoor unit fault display:

➤ Fault display of indoor unit:

fault	display
Communicate fault	F1
Fan motor fault	F4
Room temp. sensor fault	F2
Temp. sensor of coil pipe outlet fault	F3
Temp. sensor of coil pipe entrance fault	F3
Temp. sensor of coil pipe middle fault	F3

➤ Fault display of outdoor unit:

fault	display
Transducer module protection	P2
Over current	P3
Discharge temperature of compressor overheat, ambient temperature overheat	P4
DC voltage of outdoor unit abnormal	P7
Leakage or reverse valve fault	P8
Outdoor sensor fault	F6
Compressor drive fault	FC

九、 Test Model

1、Cooling

Condition	Entering Method
label Capacity	Pressing Tubro for 5 times+Setting temp. 77 °F
A2	Pressing Tubro for 5 times+Setting temp. 75 °F
B2	Pressing Tubro for 5 times+Setting temp. 73 °F
B1	Pressing Tubro for 5 times+Setting temp. 71 °F
F1	Pressing Tubro for 5 times+Setting temp. 69 °F
EV	Pressing Tubro for 5 times+Setting temp. 67 °F

A2: Indoor temp. 95 OF,Compressor max

B2: Indoor temp. 82 OF,Compressor max

B1: Indoor temp. 82 OF,Compressor min

F1: Indoor temp. 67 OF,Compressor min

EV: Indoor temp.87 OF,Compressor mid

2、Heating

Condition	Entering Method
label Capacity	Pressing Tubro for 5 times+Setting temp. 77 °F
H01	Pressing Tubro for 5 times+Setting temp. 79 °F
H11	Pressing Tubro for 5 times+Setting temp. 81 °F
H12	Pressing Tubro for 5 times+Setting temp. 83 °F
H22	Pressing Tubro for 5 times+Setting temp. 85 °F
H32	Pressing Tubro for 5 times+Setting temp. 87 °F
H2V	Pressing Tubro for 5 times+Setting temp. 89 °F

H01: Indoor temp. 62 °F, Compressor min

H11: Indoor temp. 47 °F, Compressor min

H12: Indoor temp. 47 °F, Compressor max

H22: Indoor temp. 35 °F, Compressor max

H32: Indoor temp. 17 °F, Compressor max

H2V: Indoor temp. 35 °F, Compressor mid

Function of Dual DC Inverter Type

一. System Frame Drawing

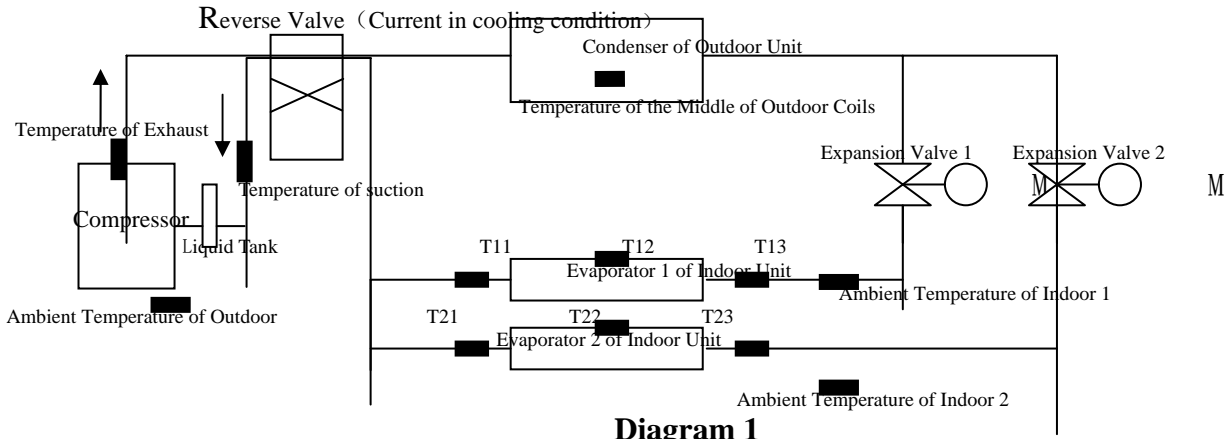

Diagram 1

二. Major Performance Index

- Voltage of Power Supply: AC220V $\pm 15\%$;
- Power of Controller: $\leq 15\text{W}$;
- Output of Three-phase Frequency Conversion:
 - Wire Voltage: 70V \sim 180V; Power: $\leq 5\text{KW}$; Frequency: 10Hz \sim 120Hz;
- Precision of Temperature Control: $\pm 1^\circ\text{C}$;
- Applicable Environment:
 - Temperature: $-20 \sim 55^\circ\text{C}$, Relative Humidity: $\leq 90\% \text{RH}$ (No dew);
- Conservation Environment:
 - Temperature: $-25 \sim 70^\circ\text{C}$, Relative Humidity: $\leq 95\% \text{RH}$ (No dew);
- Executive Standard: GB/T7725-2004 & GB4706.32-2000.

三. Input & Output of Outdoor Controller

- Outputs of one three-phase Frequency Conversion, two relays, one indicator led and one communication signal:
 - Controlling the three-phase output of compressor
 - Controlling the output of outdoor motor
 - Controlling the output of 4-way valve
 - Controlling the output of communication signals of indoor unit
 - Controlling the output of expansion valve
- Inputs of five analogue inputs (the temperature measuring points distributing as Diagram 1, all the analogues go through digital filter for disposal), and two switch signals and two communication signals:
 - Signal input of outdoor ambient temperature
 - Signal input of median temperature of outdoor coil
 - Signal input of discharge temperature of compressor
 - Signal input of suction temperature of compressor
 - Signal input of power supply voltage
 - over-heat protection signal of compressor
 - communication signal of indoor unit 1
 - communication signal of indoor unit 2
 - protection signal of outdoor IPM module

四. Operation in Cooling Mode

Control of Expansion Valve in Cooling Mode

1. Reset of Expansion Valve

In the first time , the expansion valves in all channels shall be shut down 600 steps, then the expansion valve corresponding to the indoor unit in normal communications with the outdoor unit shall be opened to standby mode steps. If accomplished, the outdoor unit shall be on standby mode, until the turn-on the indoor unit.

2. Adjustment of Expansion Valve

1) Setting of Basic Step

After the confirmation of the turn-on order of cooling mode, the expansion valve of the relevant indoor unit shall be set to the basic step and the other to zero step.

2) Adjustment of Expansion Valve according to the difference in temperature between the inlet and outlet of evaporator

During the first ten minutes of cooling mode, the expansion valve of the indoor unit at the request of cooling shall be set to the basic step. Ten minutes later, the expansion valve step and its adjust cycle shall be adjusted according to the difference in temperature between the inlet and outlet of evaporator.

Control of compressor' s frequency:

1. Range of compressor's frequency: $F_{min} \sim F_{max}$ (F_{min} : the lowest frequency, F_{max} : the highest frequency)
2. Frequency decrease protection of compressor: frequency decrease protection is prior during frequency adjustment of compressor (Frequency decrease protection have: high temperature of compressor discharge, high temperature of outdoor coil pipe, high temperature of indoor coil pipe, low temperature of compressor suction, over current)

Control of fan motor in cooling mode:

1. The fan motor of outdoor unit is ahead run 20 seconds before compressor turn on.;
2. After compressor turn off, the fan motor of outdoor unit delay 30 seconds.
3. The fan motor speed of outdoor unit as below table in normal running, it has 20 seconds delay after speed change.

Speed table of outdoor fan motor

indoor unit capacity outdoor ambient	<2hp	≥2hp	≥3hp
cooling	Speed grade		
$T < 66\text{ }^{\circ}\text{F}$	low	low	middle
$66\text{ }^{\circ}\text{F} \leq T < 81\text{ }^{\circ}\text{F}$	low	middle	high
$T \geq 81\text{ }^{\circ}\text{F}$	middle	high	high

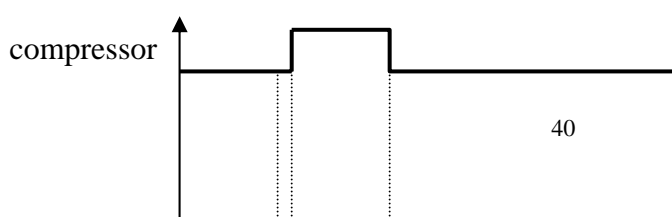

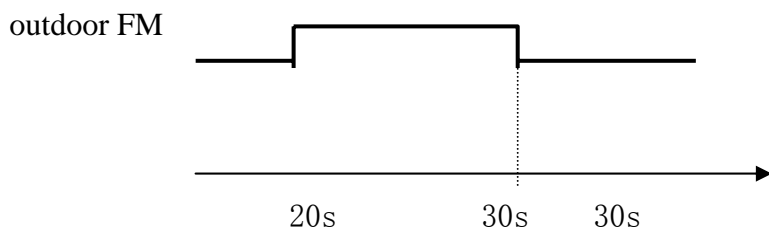

figure 3

五. Operation in Dehumidify Mode

Dehumidify mode is same as cooling mode.

六. Operation in heating Mode

Adjustment of Expansion Valve:

1. Reset of Expansion Valve

In the first time, the expansion valves in two channels shall be shut down 600 steps, then the expansion valve corresponding to the indoor unit in normal communications with the outdoor unit shall be opened to standby mode steps. If accomplished, the outdoor unit shall be on standby mode, until the turn-on the indoor unit.

2. Adjustment of Expansion Valve

1) Setting of Basic Step

After the confirmation of the turn-on order in heating mode, the expansion valve of the relevant indoor unit shall be set to the basic step.

2) Adjustment of Expansion Valve according to the difference in temperature between the inlet and outlet of evaporator

During the first ten minutes of heating mode, the expansion valve of the indoor unit shall be set to the basic step and can't adjust. Ten minutes later, the expansion valve step and its adjust cycle shall be adjusted according to the difference in temperature between the inlet and outlet of evaporator.

Control of compressor's frequency

Range of compressor's frequency: $F_{min} \sim F_{max}$ (F_{min} : the lowest frequency, F_{max} : the highest frequency)

Control of fan motor in heating mode: (figure 5)

1. The fan motor of outdoor unit is ahead run 20 seconds before compressor turn on.
2. After compressor turn off, the fan motor of outdoor unit delay 30 seconds.
3. The fan motor speed of outdoor unit as below table in normal running, it has 20 seconds delay after speed change.
4. The control of outdoor fan motor as figure 6 during defrost process.

Speed table of outdoor fan motor

indoor unit capacity outdoor ambient	<2hp	$\geq 2hp$	$\geq 3hp$
heating	Speed grade		
$T \geq 68^{\circ}F$	low	low	middle
$54^{\circ}F \leq T < 68^{\circ}F$	low	middle	high
$T < 54^{\circ}F$	middle	high	high

Control of reverse valve (figure 5)

1. The reverse valve is ahead run 20 seconds before compressor turn on.
2. After compressor turn off, the reverse valve delay 60 seconds shutdown.
3. The control of reverse valve as figure 6 during defrost process.

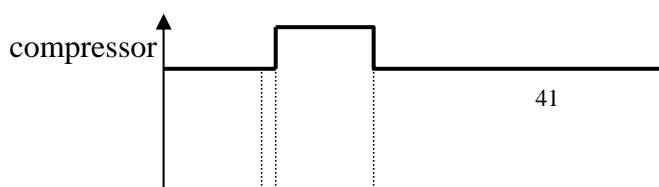

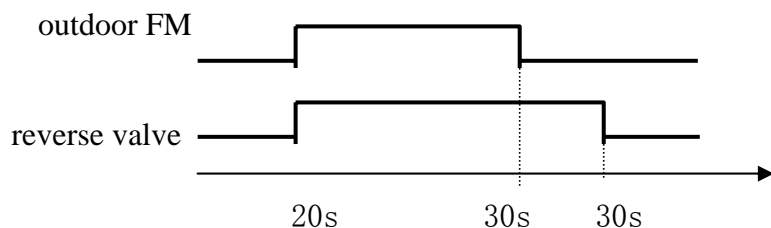

figure 5

七. Defrost of heating mode (figure 6)

1. Defrost start condition

If outdoor ambient is more than or equal to 61 °F, it can't defrost. When the time of defrost interval is end, outdoor coil pipe temp. and outdoor ambient temp. continuous meet all conditions for 5 minutes, it enter defrost process:

- 1) If outdoor ambient temp. less than or equal to 32 °F, when $T_{\text{盘}} \leq 0.8T_{\text{环}} + a$ °F (a is a adjust constant), it enter defrost process.
- 2) If outdoor ambient temp. more than 32 °F and less than or equal to 59 °F, when $T_{\text{盘}} \leq 0.2T_{\text{环}} + a$ °F, it enter defrost process.
- 3) If outdoor temp. sensor is failure, when outdoor coil temp. $T_{\text{盘}} \leq +a$ °F, it enter defrost process.
- 4) If coil temp. sensor of outdoor unit is failure, when defrost interval time is end, it enter defrost, the time of defrost is four minutes.
- 5) During the first ten minutes of outdoor running in heating mode, the time is clear and it judge whether outdoor coil pipe temp. and outdoor ambient temp. satisfy defrost condition, if the frequency of compressor is 25HZ and satisfy defrost condition, then if enter defrost process. After end defrost process or over 10 minutes it return normal running.

2. Defrost end condition

- 1) $T_{\text{盘}} \geq b$ °F (b is a adjust constant) or defrost time more than or equal to c minutes (c is a adjust constant), it exit defrost process.
- 2) When outdoor coil pipe sensor is failure, defrost time is four minutes, it exit defrost process after four minutes.

3. Interval time of defrost

- 1) Defrost interval time restriction: Max 120 minutes, Min 25 minutes.
- 2) The first frost interval time is 0 minute after heating.
- 3) The second defrost interval time is base on 60 minutes, it adjust according to below table.
- 4) Form second time, defrost interval time adjustment as below table.

Interval time (Td)	change
$T_d < 2$ minutes	Last interval time add 5 minutes
$3 \text{ minutes} \geq T_d \geq 2$ minutes	Same as last interval time
≥ 4 minutes	Last interval time reduce 5 minutes

4. Time sequence of defrost process (figure 6).

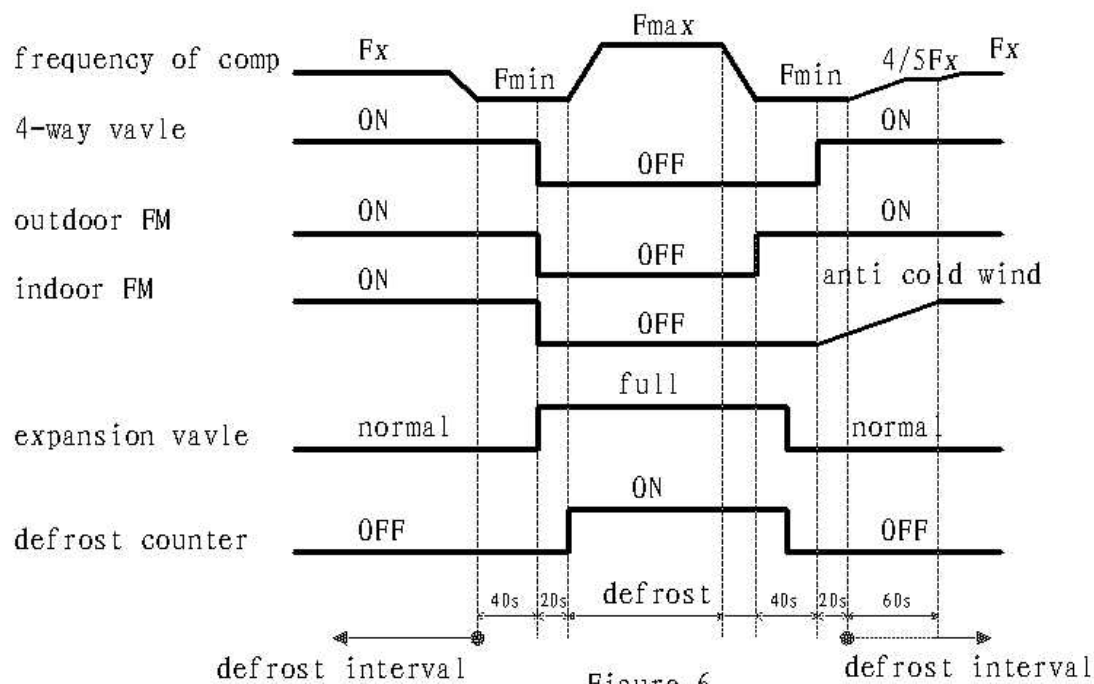

Figure 6

八. Control of oil return circle

1. Oil return circle period

When air conditioner has run for 10 minutes or accumulate time T_{msro} is end, it execute oil return circle once.

2. When compressor is running to oil return circle, the indoor unit which have communication is return oil, expand valve is open fully and compressor's frequency increase more than 3/5 of max frequency for 90 seconds, the expand valve of indoor unit which no communication is close.

九. Operation mode control of outdoor unit (dehumidify、cooling or heating)

The indoor unit can require cooling mode and dehumidify mode together, but it can't require cooling mode or dehumidify with heating mode together, the outdoor unit operate state is decided by the indoor unit which is applied first.

十. Protect function:

1. Delay protection of compressor

The compressor can't run after it stop within 3 minutes.

2. Fault protection of module

The air conditioner stop running immediately and display error code if the module is fault.

3. Protection of communicate fault

The control of outdoor unit can connect with all indoor units, when it power on, it sent data to each indoor unit continuously, if it receive a correct data from correspond indoor unit, then the indoor unit is exist. when the control of outdoor unit didn't receive communication data from indoor unit which is exist within 30 seconds, it will display communication fault. If all communication channels are failure, air conditioner will shutdown and display fault code.

4. Leakage or reverse valve fault

The air conditioner shutdown immediately when meet one of below conditions.

- 1) Heating: coil pipe temp. of outdoor unit can't decrease 3 degree within setting time and coil pipe temp. of indoor unit can't increase 3 degree all along.
- 2) Cooling: coil pipe temp. of outdoor unit can't increase 3 degree within setting time and coil pipe temp. of indoor unit can't decrease 3 degree all along.

5. High temp. protection of compressor discharge

- 1) The protection don't effect if the temp. sensor of compressor discharge fault.
- 2) The air conditioner stop running immediately and display error code when the temp. of compressor discharge more than T_{sd} .
- 3) The compressor decrease frequency until the temp. of compressor discharge less than 210°F if the temp. of compressor discharge more than 203°F . The compressor resume normal frequency when the temp. of compressor discharge less than 194°F .

6. Temperature switch protection of compressor

The air conditioner will shutdown immediately and display fault code if the temp. switch of compressor switch off.

7. High temp. protection of middle coil pipe of condenser

- 1) The protection don't effect if the temp. sensor of middle coil pipe fault.
- 2) The compressor decrease frequency until the temp. of middle coil pipe less than 136°F .if the temp. of middle coil pipe more than 134°F .
- 3) It resume normal frequency when the temp. of middle coil pipe less than 133°F .

8. High temp. protection of indoor coil pipe

- 1) The compressor decrease frequency until the temp. of indoor coil pipe more than $(T_{sce}-2)$ if the temp. of indoor coil pipe less than $(T_{sce}-2)$ in cooling mode.
The compressor decrease frequency until the temp. of indoor coil pipe less than $(T_{sce}+2)$ if the temp. of indoor coil pipe more than $(T_{sce}+2)$ in heating mode.
- 2) It resume normal frequency when the temp. of indoor coil pipe less than T_{sce} (cooling mode) or less than T_{she} (heating mode).

9. Low temp. protection of compressor suction

- 1) The protection don't effect if the temp. sensor of compressor suction fault or compressor don't run or in heating mode..
- 2) The compressor decrease frequency until the temp. of compress suction more than T_{ss} if the temp. of compressor suction less than T_{ss} . It resume normal frequency when the temp. of compressor suction more than $(T_{ss}+2)$.

10. Fault protection of outdoor sensor

The air conditioner is running at the frequency of less than $(3/5)*F_{max}$ and display fault code if the temp. sensor of compressor discharge fault, or the temp. sensor of outdoor middle coil pipe fault, or the temp. sensor of compressor suction fault, or the temp. sensor of outdoor ambient fault.

11. High temp. of ambient

- 1) The protection don't effect if the temp. sensor of outdoor ambient fault.
- 2) The air conditioner stop running immediately and display error code if outdoor ambient temp. more than 131°F or less than -4°F .

12. Over current protection of compressor

- 1) The air conditioner stop running immediately and display error code when input current more than or equal to I_{max} .
 - 2) The compressor decrease 2Hz per 3 seconds until input current less than or equal to $(I_{max}-13)$ when the input current more than $(I_{max}-13)$.
 - 2) The compressor decrease 1Hz per 3 seconds until input current less than or equal to $(I_{max}-16)$ when the input current more than $(I_{max}-16)$.
 - 3) It resume normal frequency when the input current less than or equal to $(I_{max}-20)$.
13. DC voltage of wire protection
- 1) The air conditioner stop running and display DC voltage abnormal when it less than 260V.
 - 2) The compressor decrease frequency and display FA6 when DC voltage less than 285V.
 - 3) The air conditioner resume normal running when DC voltage more than 290V.

十一、 Outdoor unit fault of indoor unit display

fault	display
Transducer module protection	P2
Over current	P3
Discharge temperature of compressor overheat, ambient temperature overheat	P4
DC voltage of outdoor unit abnormal	P7
Leakage or reverse valve fault	P8
Outdoor sensor fault	F6
Compressor drive fault	FC

12. TROUBLESHOOTING

WARNING!!!

When Power Up – the whole outdoor unit controller, including the wiring, is under HIGH VOLTAGE!!!

Never open the Outdoor unit before turning off the Power!!!

When turned off, the system is still charged (400V)!!!

It takes about 3 Min. to discharge the system.

Touching the controller before discharging may cause an electrical shock!!!

For safe handling of the controller please refer to section 1.6 below.

1.1 Air Conditioner Failures and Corrective Actions

F1:

- 1, Communicate wire cut off ,loose or wrong wiring---check wires
- 2, Communication interfere---check wires connection with circuit diagram.(earth line must be wired)。

F2:

- 1, Temp. sensor of indoor room short or cut off.---change sensor

F3:

- 1, Temp. sensor of indoor coil pipe outlet short or cut off.---change sensor.
- 2, Temp. sensor of indoor coil pipe entrance short or cut off.---change sensor.
- 3, Temp. sensor of indoor coil pipe middle short or cut off.---change sensor.

F4:

- 1, PG motor fault.---change motor. PG.
- 2, Fixed screw loose.---fix cross flow fan.
- 3, Communication interfere. (earth wire can't with communicate wire in same cable)---check cable.

F6:

- 1, Temp. sensor of discharge short or cut off.---change sensor.
- 2, Temp. sensor of suction short or cut off.---change sensor.
- 3, Temp. sensor of condenser middle short or cut off.---change sensor.

P2: (auto-restart)

- 1, over current protection of inverter module.
- 2, over voltage protection of inverter module.
- 3, high temp. protection of inverter module.

P3:

- 1, over load (outdoor ambient temp. more high).
- 2, Voltage over low.

P4:

- 1: discharge temp. too high.---maybe leak refrigerant, add refrigerant.
- 2: outdoor ambient temp. too high, if $(T < -4^{\circ}\text{F}, T > 131^{\circ}\text{F})$, it will alarm.
- 3: temp. switch of compressor cut off.。
- 4: Communication interfere. (earth wire can't with communicate wire in same cable)---check cable.

P7:

- 1, PFC board fault.---change PFC board.
- 2, Communication of main board and PFC board fault.---check wires of main board and PFC board.

P8:

- 1, Less refrigerant.---add refrigerant.
- 2, Coil pipe sensor can't contact with coil pipe.
- 3, 4-way valve fault.---change 4-way vavle fault.

13. EXPLODED VIEWS AND SPARE PARTS LISTS

13.1 outdoor unit : TAS-09EH/O

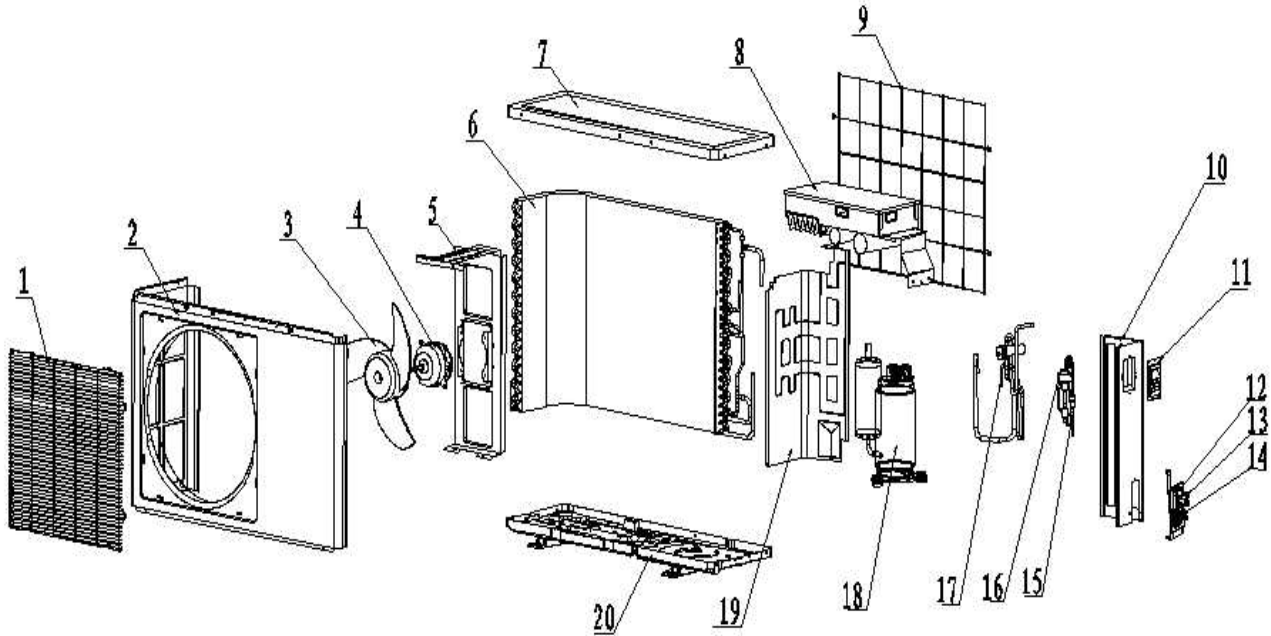

NO.	description	name	number	NO.	description	name	number
1	前网罩	Front Grill	1	11	电器盒盖	Top of the Electric box	1
2	面板	Front Plate	1	12	阀座板	Valve installation plate	1
3	轴流风轮	Axial flow fan	1	13	低压阀	Low-pressure valve	1
4	电机	Motor	1	14	高压阀	Ligh-pressure valve	1
5	电机支架	Motor support	1	15	毛细管组件	Capillary Assy	1
6	冷凝器	Condenser	1	16	电子膨胀阀	Electronic expansion valve	1
7	顶盖板	Top panel	1	17	四通阀组件	Four-way valve assembly	1
8	电控盒	Electric box	1	18	压缩机	Compressor	1
9	背网	Rear Grill	1	19	中隔板	Partition board	1
10	右侧板	Right panel	1	20	底盘	Base	1

13.2 outdoor unit : TAS-12EH/O

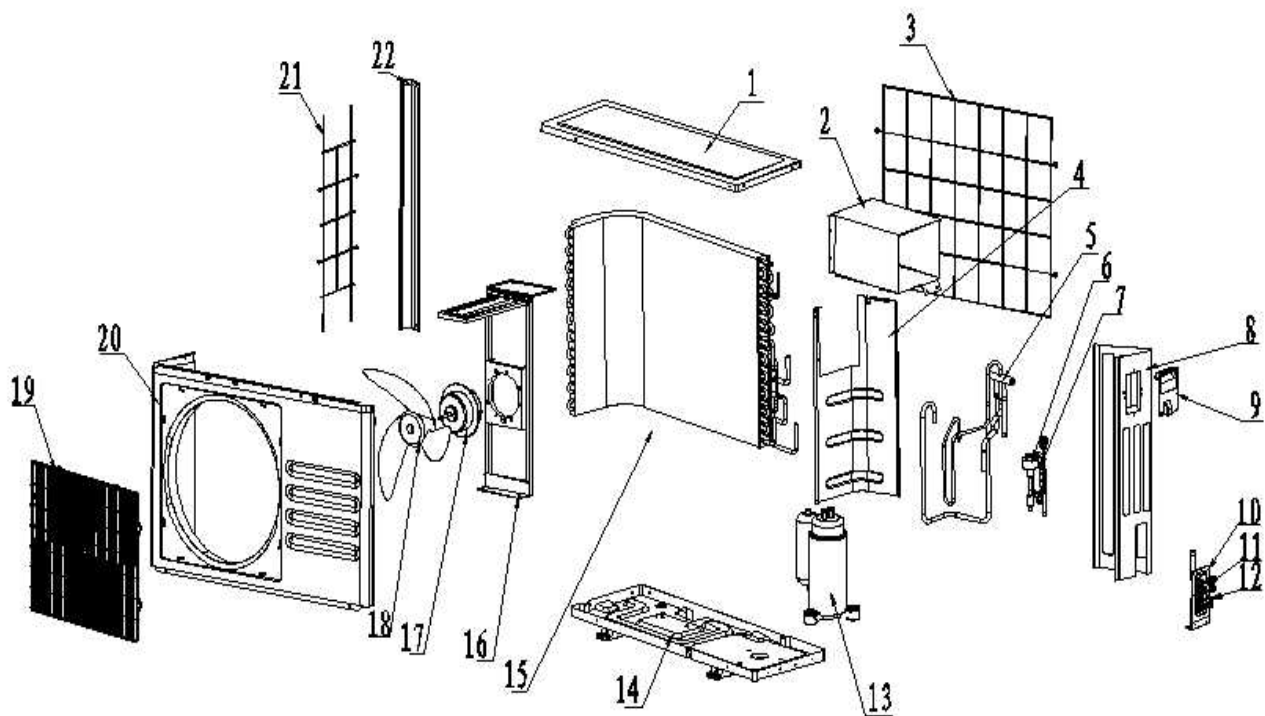

NO.	description	name	number	NO.	description	name	number
1	顶盖板	Top panel	1	12	高压阀	High-pressure valve	1
2	电控盒	Electric box	1	13	压缩机	Compressor	1
3	背网	Rear Grill	1	14	底盘	Base	1
4	中隔板	Partition board	1	15	冷凝器	Condenser	1
5	四通阀	Four-way valve	1	16	电机支架	Motor support	1
6	电子膨胀阀	Electronic expansion valve	1	17	电机	Motor	1
7	干燥过滤器	Desiccation filter	1	18	轴流风机	Axial flow fan	1
8	右侧板	Right panel	1	19	前网罩	Front Grill	1
9	大抽手	Large handle	1	20	前面板	Front Plate	1
10	阀座板	Valve installation plate	1	21	左护网	Left protect net	1
11	低压阀	Low-pressure valve	1	22	左侧板	Left panel	1

13.3 outdoor unit : TAS-18EH/O

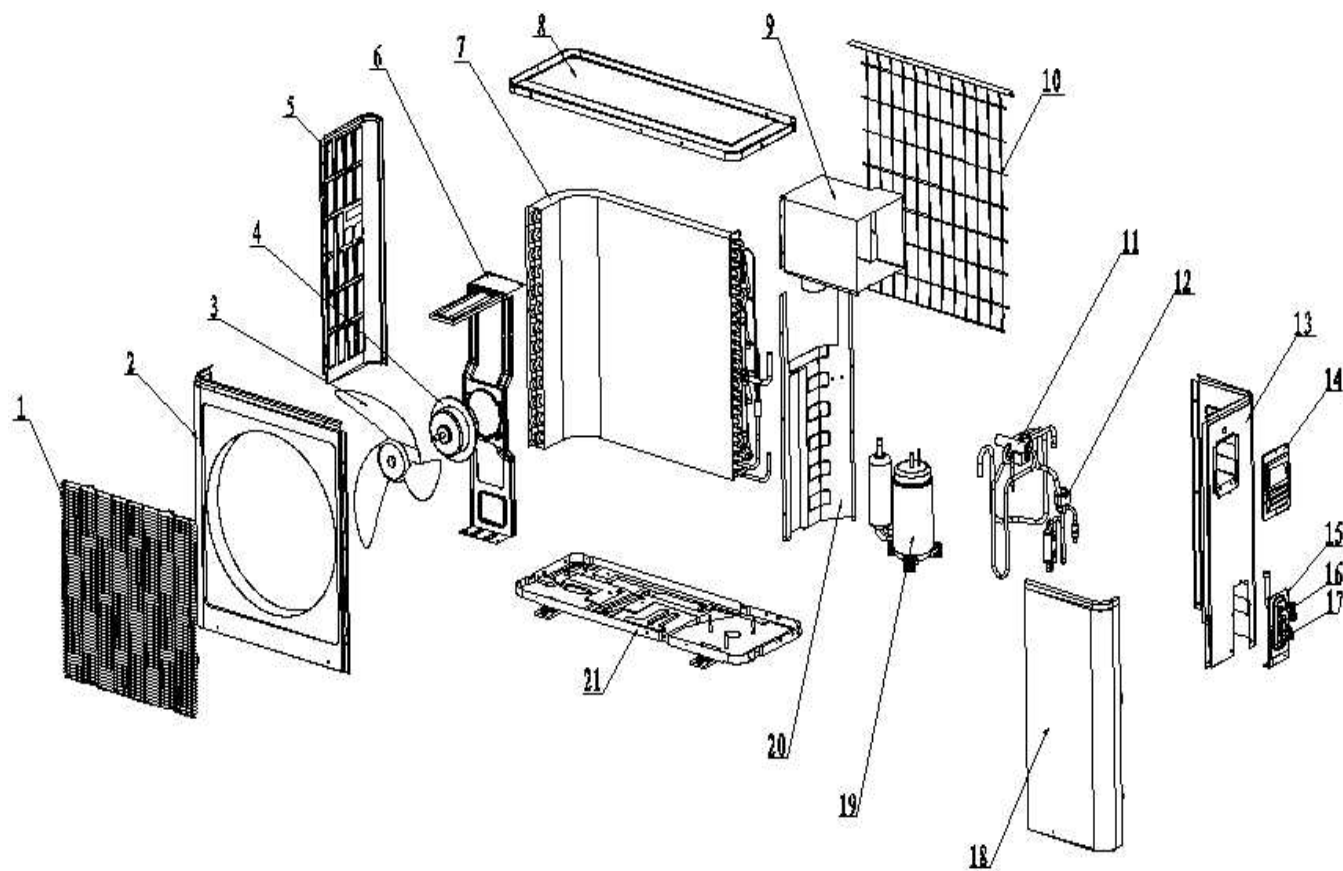

NO.	description	name	number	NO.	description	name	number
1	前网罩	Front Grill	1	11	四通阀组件	Four-way valve assembly	1
2	面 板	Front Plate	1	12	电子膨胀阀	Electronic expansion valve	1
3	轴流风轮	Axial flow fan	1	13	右侧板	Right panel	1
4	电 机	Motor	1	14	电器盒盖	Top of the Electric Box	1
5	左侧板	Left panel	1	15	阀座板	Valve installation plate	1
6	电机支架	Motor support	1	16	低压阀	Low-pressure valve	1
7	冷凝器	Condenser	1	17	高压阀	High-pressure valve	1
8	顶盖板	Top panel	1	18	维修板	Maintenance plate	1
9	电器盒	Electric box	1	19	压缩机	Compressor	1
10	背网	Rear Grill	1	20	中隔板	Partition board	1
				21	底盘	Base	1

13.4 outdoor unit : TAS-24EH/O

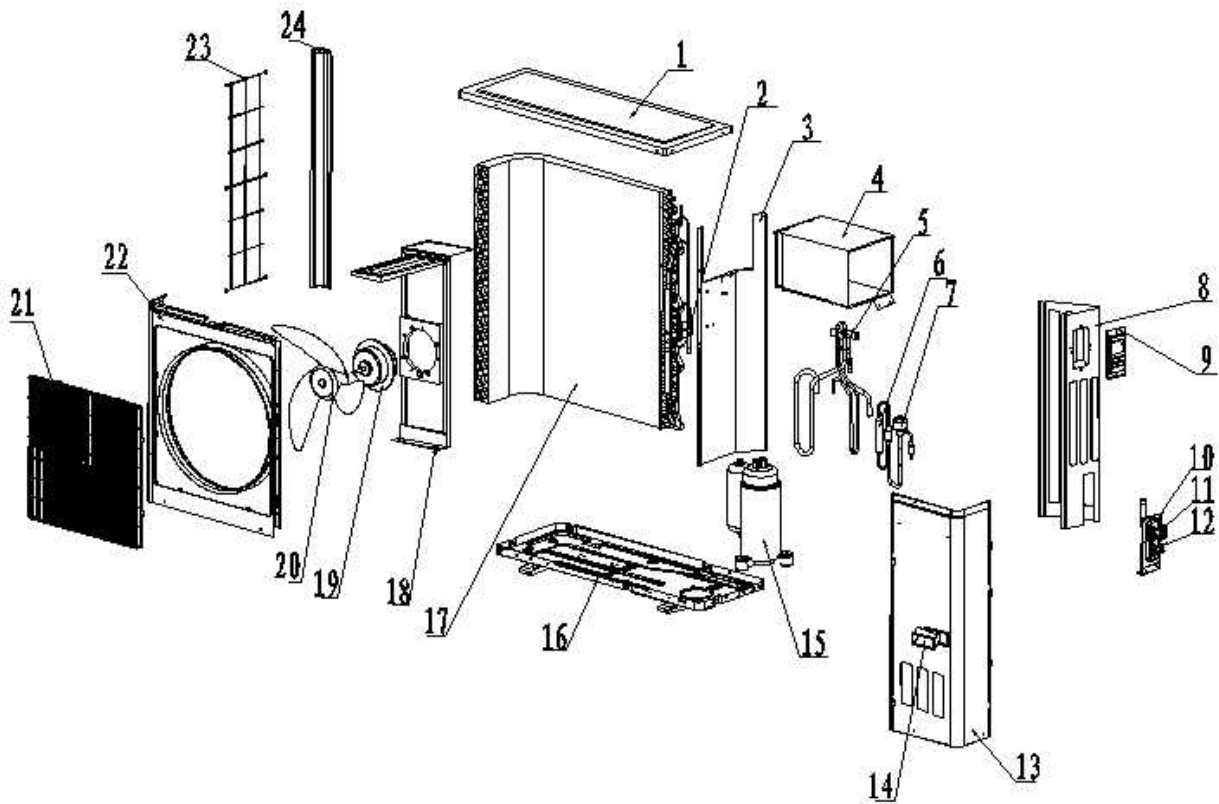

NO.	description	name	number	NO.	description	name	number
1	顶盖板	Top panel	1	13	维修板	Maintenance plate	1
2	减振块	Anti-vibration pad	1	14	小抽手	Small handle	2
3	中隔板	Partition board	1	15	压缩机	Compressor	1
4	电控盒	Electric box	1	16	底盘	Base	1
5	四通阀	Four-way valve	1	17	冷凝器	Condenser	1
6	干燥过滤器	Desiccation filter	1	18	电机支架	Motor support	1
7	电子膨胀阀	Electronic expansion valve	1	19	电机	Motor	1
8	右侧板	Right panel	1	20	轴流风机	Axial flow fan	1
9	电器盒盖	Top of the Electric box	1	21	前网罩	Front Grill	1
10	阀座板	Valve installation plate	1	22	前面板	Front Plate	1
11	低压阀	Low-pressure valve	1	23	左护网	Left protect net	1
12	高压阀	High-pressure valve	1	24	左侧板	Left panel	1

13.5 outdoor unit : TAS-18MVH/O

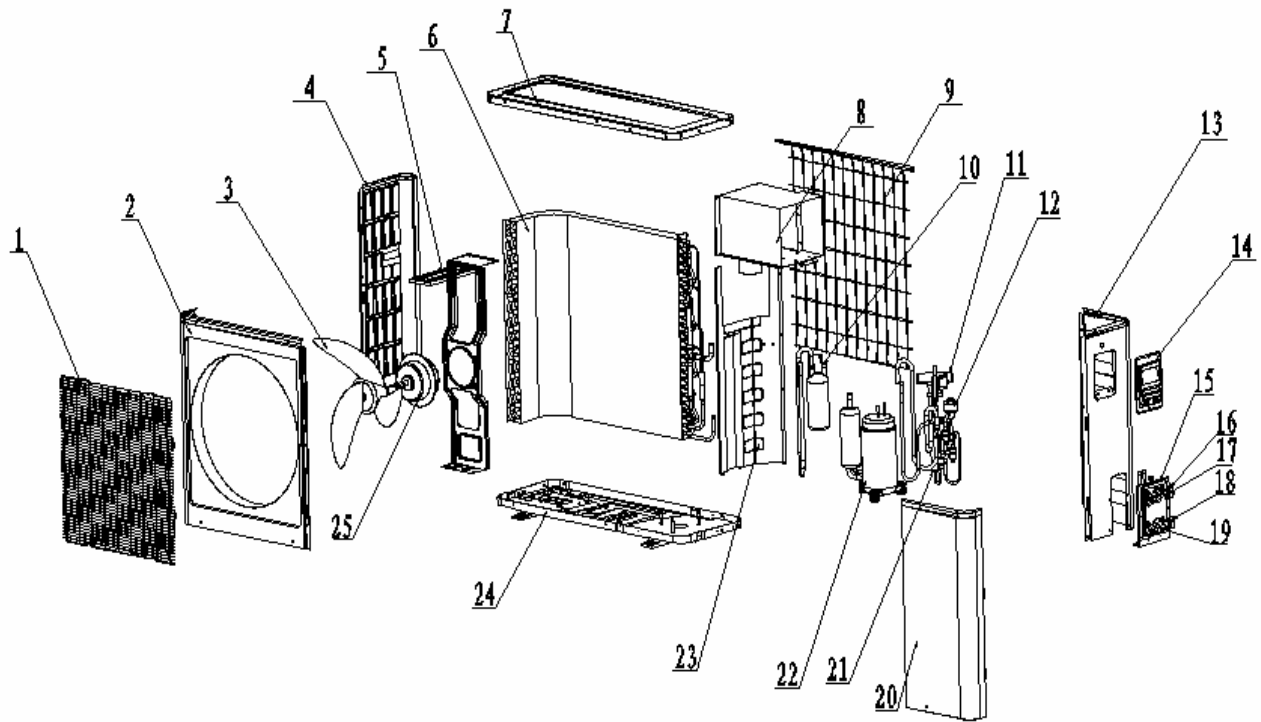

NO.	description	name	number	NO.	description	name	number
1	前网罩	Front Grill	1	14	电器盒盖	Top of the Electric Box	1
2	面 板	Front Plate	1	15	阀座板	Valve installation plate	1
3	轴流风轮	Axial flow fan	1	16	A 机 DN4 截止阀	DN4 valve	1
4	左侧板	Left panel	1	17	A 机 DN10 截止阀	DN10 valve	1
5	电机支架	Motor support	1	18	B 机 DN4 截止阀	DN4 valve	1
6	冷凝器	Condenser	1	19	B 机 DN10 截止阀	DN10 valve	1
7	顶盖板	Top panel	1	20	维修板	Maintenance plate	1
8	电器盒	Electric box	1	21	干燥过滤器	Desiccation filter	1
9	背网	Rear Grill	1	22	压缩机	Compressor	1
10	汽液分离器	Steam liquid segregator	1	23	中隔板	Partition board	1
11	四通阀组件	Four-way valve assembly	1	24	底盘	Base	1
12	电子膨胀阀	Electronic expansion valve	2	25	电 机	Motor	1
13	右侧板	Right panel	1				

13.6 outdoor unit : TAS-24MVH/O

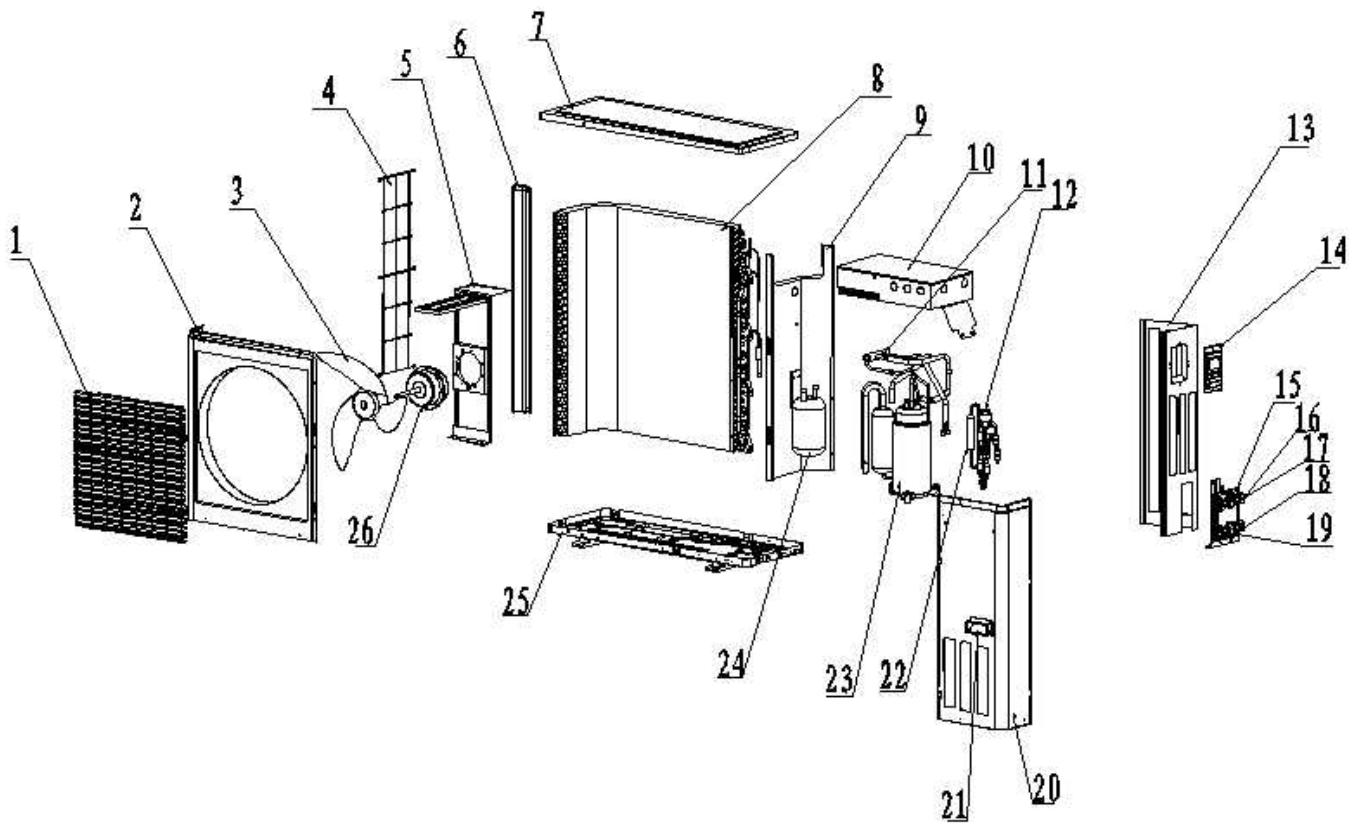

NO.	description	name	number	NO.	description	name	number
1	前网罩	Front Grill	1	14	电器盒盖	Top of the Electric Box	1
2	面 板	Front Plate	1	15	阀座板	Valve installation plate	1
3	轴流风轮	Axial flow fan	1	16	A 机 DN4 截止阀	DN4 valve	1
4	左护网	Left protect net	1	17	A 机 DN10 截止阀	DN10 valve	1
5	电机支架	Motor support	1	18	B 机 DN4 截止阀	DN4 valve	1
6	立 柱	Pillar	1	19	B 机 DN10 截止阀	DN10 valve	1
7	顶盖板	Top panel	1	20	维修板	Maintenance plate	1
8	冷凝器	Condenser	1	21	小抽手	Small handle	2
9	中隔板	Partition board	1	22	干燥过滤器	Desiccation filter	1
10	电器盒	Electric box	1	23	压缩机	Compressor	1
11	四通阀组件	Four-way valve assembly	1	24	油气分离器	Oil and steam separator	1
12	电子膨胀阀	Electronic expansion valve	2	25	底盘	Base	1
13	右侧板	Right panel	1	26	电 机	Motor	1

APPENDIX A

INSTALLATION AND OPERATION MANUAL

▶ INSTALLATION MANUAL CMV

Foreword

This instruction Manual is the universal-purpose version for the models of separate wall-mounted air conditioners manufactured by our Co. The appearance of the units that you purchase might be slightly different from the ones described in the Manual, but it does not affect your proper operations and usage.

Please read carefully the sections corresponding to the specific model you choose, and keep the Manual properly so as to facilitate your reference at later time.

IMPORTANT!

Please Read Before Starting

This air conditioning system meets strict safety and operating standards.

As the installer or service person, it is an important part of your job to install or service the system so it operates safely and efficiently.

For safe installation and trouble-free operation, you must:

- ? Carefully read this instruction booklet before beginning.
 - ? Follow each installation or repair step exactly as shown.
 - ? Observe all local, state, and national electrical codes.
- ? Pay close attention to all danger, warning, and caution notices given in this manual. **WARNING:** This symbol refers to a hazard or unsafe practice which can result in severe personal injury or death.

CAUTION: This symbol refers to a hazard or unsafe practice which can result in personal injury and the potential for product or property damage.

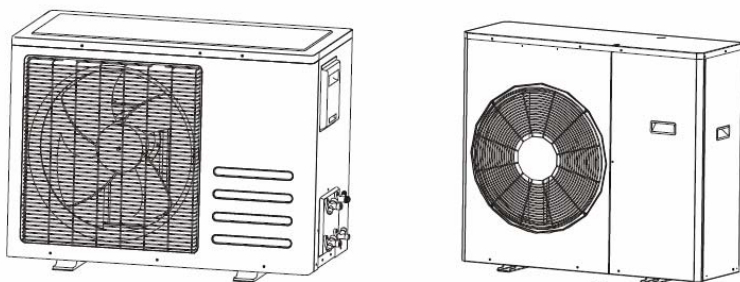

CONTENTS

LOCATION OF OUTDOOR UNIT	1
ELECTRICAL CONNECTION BETWEEN INDOOR AND OUTDOOR UNIT	3
INSTALLATION/SERVICE TOOLS (ONLY FOR R410A PRODUCT)	7
REFRIGERANT TUBING	9
FINAL TASKS	11

NOTE: This manual is for Multi split applications only.

For indoor units installation please refer to the installation manual supplied

within the indoor unit packa

1 LOCATION OF OUTDOOR UNIT

Select the location considering the following:

OUTDOOR UNIT

- 1 .The location must allow easy servicing and provide good air circulation as shown in fig2. 2.The unit may be suspended from a wall by a bracked(Optional)or located in a free standing position on the floor(preferably slightly elevated).
- 3.If the unit is suspended , ensure that the bracket is firmly connected and the wall is strong enough to withstand vibrations.
- 4.Unit location should not disturb neighbours with noise or exhaust air stream.
- 5.Place the mounting pads under the unit legs.
- 6.Refer to figure 2 for allowed installation distances.

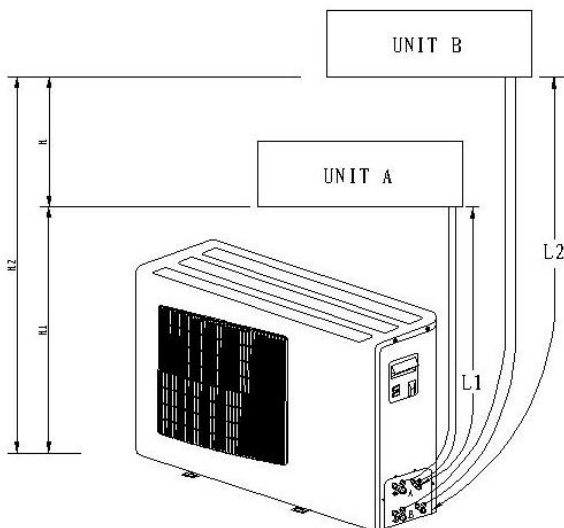
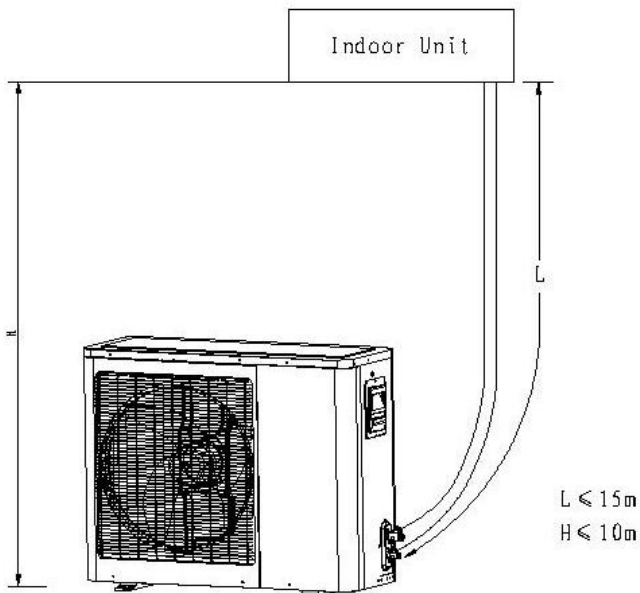

Fig 1

$$\begin{aligned} L1, L2 &\leq 25m \\ L1+L2 &\leq 30m \\ H1, H2 &\leq 10m \end{aligned}$$

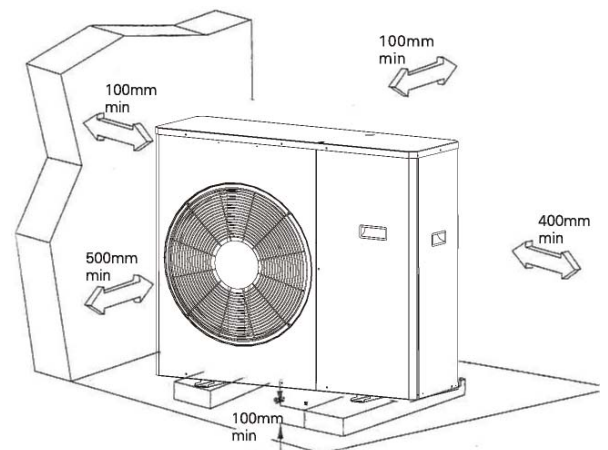

Fig 2

2 ELECTRICAL CONNECTION BETWEEN OUTDOOR AND INDOOR UNIT

ELECTRICAL REQUIREMENTS

Electrical wiring and connections should be made by qualified electricians and in accordance with local electrical codes and regulation. The air conditioner units must be grounded. The air conditioner units must be connected to an adequate power outlet from a separate branch circuit protected by a time delay circuit breaker, as specified on unit's nameplate. Voltage should not vary beyond $\pm 10\%$ of the rated voltage.

1. Remove the power supply cable that is connected to the indoor unit!

2. To connect the indoor units to the outdoor units, use the following electrical cables.

Electrical connections:

Power input cable: 1 group 3 wires $\times 2.5\text{mm}^2$

cable between indoor and

outdoor units: 1 group 4 wires $\times 1.0\text{mm}^2$

see Fig 6.7.8.9.10 for detail .

3. Prepare the cable ends for the power input and for the cables between outdoor and indoor units as shown in figure 3a and 3b respectively.

4. Connect the cable ends to the terminals of the indoor and outdoor units , as show in fig4, figs.

Please select corresponding connection according to the different indoor units. 5. Secure the multiple wire power cable with the cable clamps.

• Power input cable

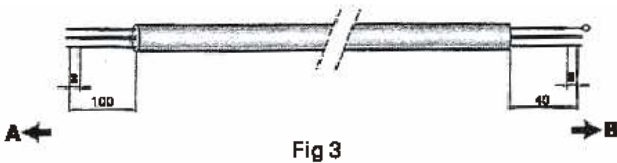

Fig 3

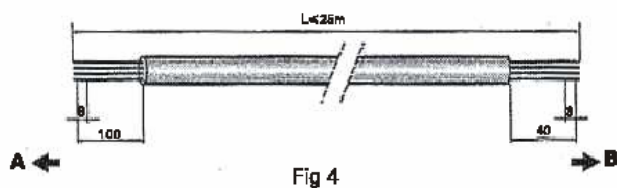

Fig 4

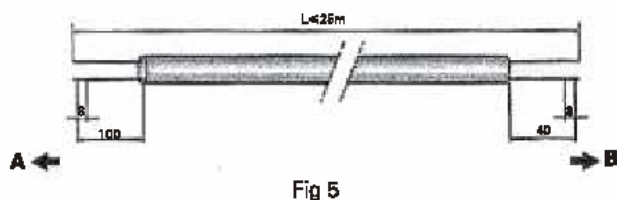

Fig 5

3 INSTALLATION/SERVICE TOOLS (ONLY FOR R410A PRODUCT)

CAUTION

New Refrigerant Air Conditioner Installation

This air conditioner adopts the new HFC refrigerant (R410A) which does not destroy ozone layer. R410A refrigerant is approx . 1.6 times of refrigerant R22. Accompanied with the adoption of the new refrigerant , the refrigeration machine oil has also been changed.

Therefore,during installation work, be sure that water , dust , former refrigerant , or refrigeration machine oil does not enter into the new type refrigerant R410A air conditioner circuit.The system must not be left open to the atmosphere for any reason for any period of time as the systems oil quickly absorbs moisture and will contaminate and damage the system.

A refrigerant liquid line drier is recommended.

To prevent mixing of refrigerant or refrigerating machine oil ,the sizes of conneting sections of charging port on main unit and installation tools are different from those used for the conventional refrigerant units. Accordingly,special tools are required for the new refrigerant (R410A) units, For connecting pipes use new and clean piping materials with high pressure fitting made for R410A only, so that water and/or dust does not enter.Moreover, do not use the existing piping because there are some problems with presure fittings and possible impurities in existing piping .

Changes in the product and components

In air conditioners using R410A ,in order to prevent any other refrigerant from being accedentially charged .the service port diameter size of the outdoor unit control valve (3 way valve) has been changed. (1/2 UNF 20 threads per inch)

- In order to increase the pressure resisting strength of the refrigerant piping ,flare processing diameter and opposing flare nuts sizes have been changed.(fot copper pipes with nomensions 1/2 and 5/8)

New tools for R410A

Nes tools for R410A	Applicable to R22 model	Chages
Gauge manifold	x	As the working pressure is high ,it is impossible to measure the working pressure using conventional gauges . In order to prevent any other refrigerant from being charged , the port diameters have been changed.
Charge hose	x	In order to increase pessure resisting strength. hose materials and port sizes have been changed(to 1 /2 UNF 20 threads per inch). When puchasing a charge hose,be sure to confirm the port size.
Electronic balance for refrigerant charging		As working pressure is. high and gasification speed is fat ,it is difficult to read the indicated value by means of charging cylinder ,as air bubbles occur.
Torque wrench (nominal dia.1/2,5/8)	x	The size of opposing flare nuts have been increased ,incidentally,a common wrench is used for nominal diameters 1/4 and 3/8.

Flare tool (clutch type)	0		By increasing the clamp bar'receiving hole size , strength of spring in the tool has been improved.
Gauge for projection adjustment	-		Used when flare is made by using conventional flare tool.
Vacuum pump adapter	0		Connected to conventional vacuum pump,it is necessary to use an adapter to prevent vacuum pump oil from flowing back into the charge hose , The charge hose connecting part has two ports-one for conventional refrigerant (7/16 UNF 20 theads per inch)and one for R41 OA ,if
Gas leakage detector	x		Exclusive for HFC refrigerant

- Incidentally,the "refrigerant cylinder"comes with the refrigerant designation(R410A)and protector coating in the U.S's ARI specified rose color (Ari color code; PMS 507).
- Also the "charge port and packing for refrigerant cylinder"requires 1/2 UNF 20 theads per inch corresponding to the charge pOse's port size.

4 REFRIGERANT TUBING

CONNECT THE INDOOR TO THE OUTDOOR UNIT

The indoor unit contains a small quantity of nitrogen. Do not unscrew the nuts from the unit until you are ready to

connect the tubing. The outdoor unit is supplied with sufficient refrigerant charge (R410A). Refer to outdoor unit nameplate.

To prevent crushing, bend tubes using a bending tool.

NOTE: Use refrigeration R410A type copper tubing only.

1. Open the valve cover.
2. Use tubing diameter that corresponds to the tubing diameter of the indoor and outdoor units. Note that the liquid and suction tubes have different diameters. (See tube size, torque tightening table.)
3. Place flare nuts on tube ends before preparing them with a flaring tool. Use the flare nuts that are mounted on the supplied outdoor and indoor units.
4. Connect the all ends of the tubing to the indoor and outdoor units. Notice the sign. All ends should correspond one by one.
5. Insulate each tube separately, and their unions, with at least 6mm thick of insulation. Wrap the

refrigerant tubing, drain hose and electric cables together with a vinyl tape (UV protected)

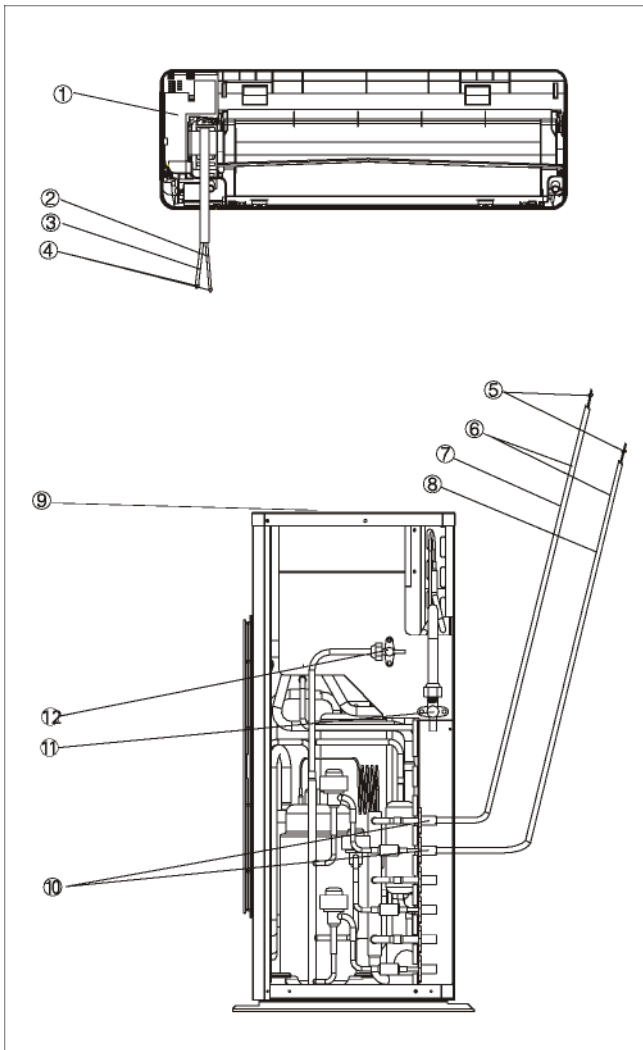

Fig 11

1. INDOOR UNIT
2. Liquid tube (small dia.)
3. Suction tube (large dia.)
4. Plugs
5. Flare nuts
6. Tubing between units
7. Suction tube
8. Liquid tube
9. OUTDOOR UNIT
10. Flare nuts
11. Suction valve (larger)
12. Liquid valve (small)

NOTE: 1. For unit use connections A, B and D
 2. For large indoor unit of 5.0KW Use the lower connection (unit D) and use the 3/8"-1/2" transition (supplied)
 3. The electric control channel must match the tube channel.

Caution!

When unscrewing the valve caps, do not stand in front of them or the spindles at any time, as the system is under pressure.

Tightening torques of unions and valve caops:

TUBE SIZE	TORQUE
Liquid line 1/4"	15-20 N.M.
Suction line 3/8"	30-35 N.M.
Suction line 1/2"	50-54 N.M.
Suction line 5/8"	75-78 N.M.

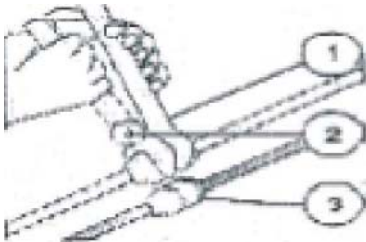

Fig 12
1. Wrench
2. Torque wrench
3. Union



Fig 13 To prevent refrigerant
leakage, coat the flared
surface with
refrigeration oil

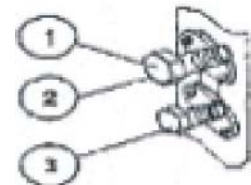
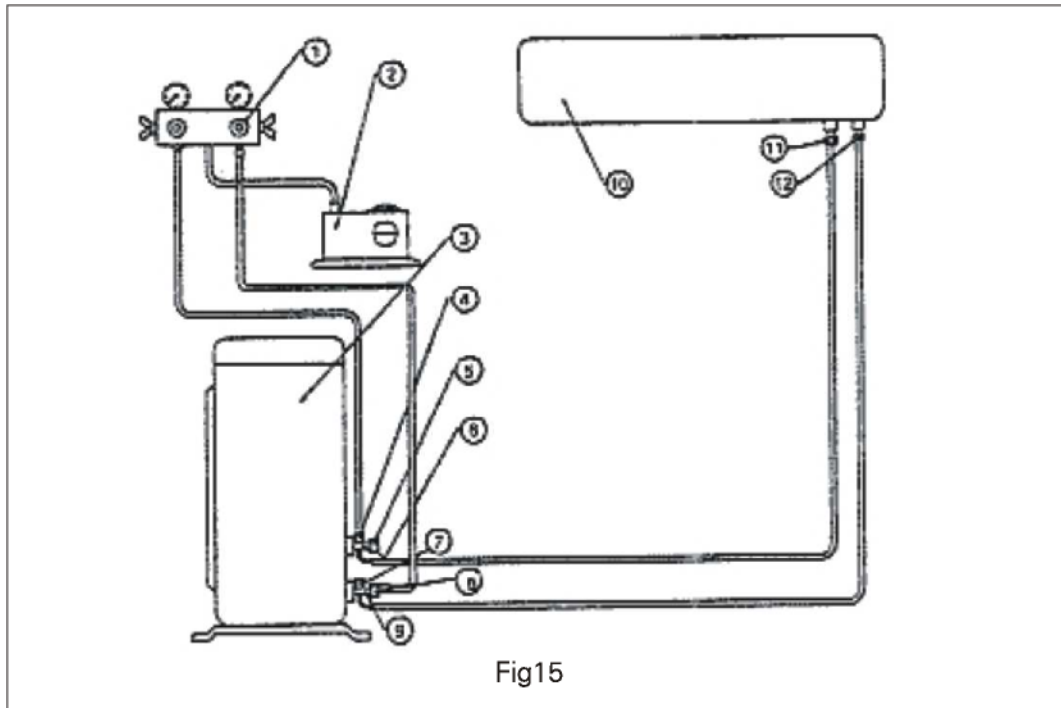

Fig 14 1. Suction
valve 2. Service port
3. Liquid valve

EVACUATION OF THE **REFRIGERATION** TUBES AND THE INDOOR UNIT

After connecting the unions of the indoor and outdoor units, evacuate the air from the tubes and indoor unit as follows:

1. Connect the charging hoses with a push pin to the low and high sides of the charging set and the service ports of the suction and liquid valves.
Be sure to connect the end of the charging hose with the push pin to the service ports.
2. Connect the center hose of the charging set to a vacuum pump.
3. Open Fully the low and high pressure sides of the manifold gauge valves.
4. Turn on the vacuum pump. Perform evacuating for at least 30 minutes and then confirm that the needle in the gauge moves from 0 MPa(0cm Hg) to -0.1 MPa(-76cm Hg).
5. Close the valves of the low and high sides of the charging set and turn off the vacuum pump. After few minutes, if the gauge needle has moved, there is a leak which must be found and repaired before moving to the next stage.
6. Disconnect the charging hose from the vacuum pump and from the service ports of the suction and liquid valves.
7. Tighten the service port caps of suction and liquid valves.
8. Remove the valve caps from all valves, and open them using a hexagonal Allen wrench,
9. Securely tighten the caps onto all of the valves.
10. Check for gas leaks from all the connecting position. Test with electronic leak detector or with a sponge immersed in soapy water for bubbles.



- | | | |
|-----------------|-----------------|-----------------------------|
| 1 .Charging set | 5.Cap | 9.Liquid valve |
| 2.Vacuum pump | 6.Suction valve | 10.INDOOR UNIT |
| 3.OUTDOOR UNIT | 7.Service valve | 11.Suction flare connection |
| 4.Service valve | 8.Cap | 12.Liquid flare connection |

5 FINAL TASKS

- 1 .Check all valve caps and ensure that they had tightened properly.Close the valve cover.
- 2.Fill gaps on the wall between hole sides and tubing with sealer.
- 3.Attach wiring and tubing to the wall with clamps where necessary.
- 4.Operate the unit for no less than 5 minutes at heating or cooling mode.
- 5.Explain filter removal,cleaning and installation.
- 6.Operate the air conditioner together with the customer and explain all functions.
- 7.Give the operating and installation manuals to the customer