

This Owner's Manual is provided and hosted by Appliance Factory Parts.



ADAMS SPT-300PS Owner's Manual

**[Shop genuine replacement parts for ADAMS
SPT-300PS](#)**



[Find Your ADAMS HVAC Parts - Select From 98 Models](#)

----- Manual continues below -----

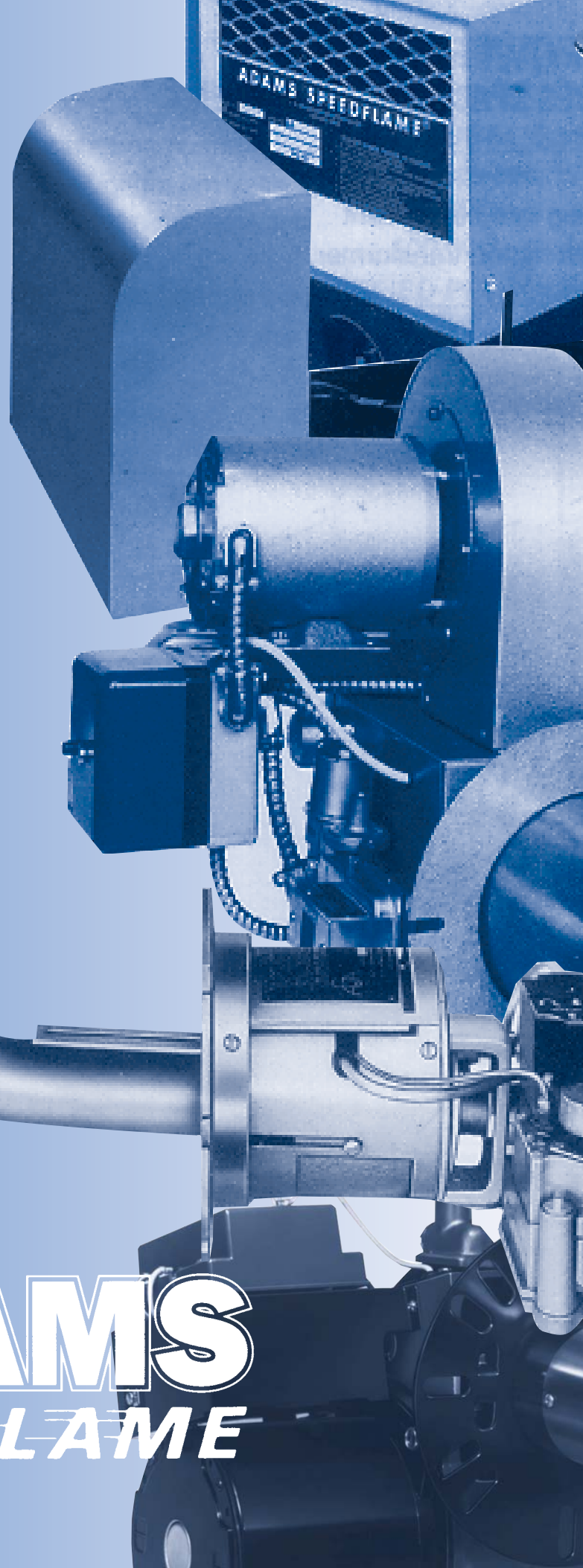
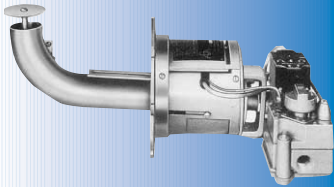
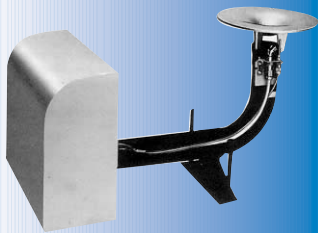
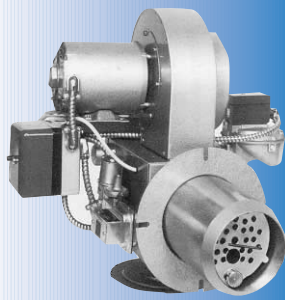

ADAMS

SPEEDFLAME

HU UPSHOT AND HA INSHOT BURNERS

Rugged cast iron adjustable venturi – places the flame in optimum location for oil furnaces.

Readily removable pilot, flame spreader and pilot lighter.

Durable pre-drilled steel mounting flange – for easy mounting.

Optional adjustable orifice available.

Gas Saver model available – pilot light is on only during heating cycle.

Optional collar flange reduces tube length.

SPT ECONOMY UPSHOT BURNER

Adjustable venturi length and height – places flame in optimum location for virtually all coal furnaces or boilers. Rugged cast iron flame spreader.

Extremely compact design – fits where other burners will not.

Trim plate mounting for ease of installation.

Optional adjustable orifice, extra length riser available.

Gas Saver model available – pilot light is on only during heating cycle.

HP-SPACESAVER POWER BURNER

**COMPACT DESIGN – SAVES SPACE –
ADJUSTABLE ORIFICE**

Fits the smallest enclosures.

Easily accessible air and firing rate adjustment.

Completely factory wired with motor, transformer, and terminal block mounting on slide out chassis.

Slide out gas valve and manifold.

Rugged steel mounting flange, 5" or 8" extension sleeve optional.

Constant or intermittent pilot.

G-2-POWER GAS BURNER

A revolutionary partial pre-mix system uses Adams unique eductor-venturi concept.

High static pressure capabilities assure firing even under adverse conditions.

For dependable direct spark ignition, the burner uses a separate high voltage transformer.

A special designed manifold permits external orifice changes without the need of disassembling the burner.

Six different stainless steel flame retention heads available to cover most input ranges.

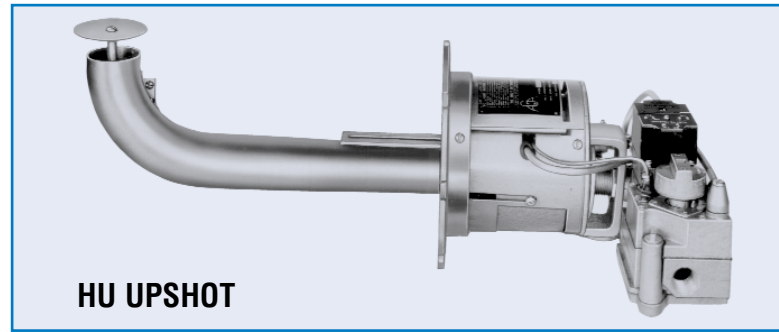

HU UPSHOT



HA INSHOT



SPT ECONOMY



HP-SPACESAVER

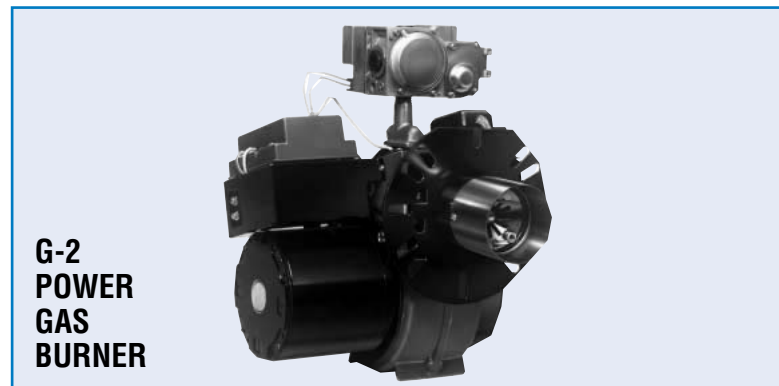

**G-2
POWER
GAS
BURNER**

GAS BURNERS

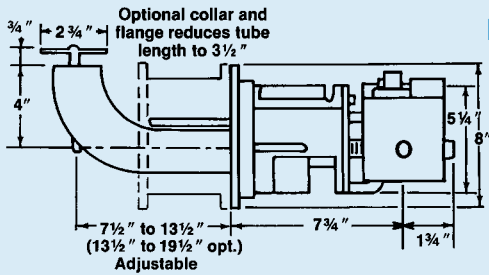

**Dimensions
HU Left Side**

Model	BTU/Hr. Input		Gas Pipe Connection	Approximate Shipping Wt.
	Maximum	Minimum		
NATURAL GAS				
HU-300	290,000	50,000	3/4"	16 lbs.
PROPANE GAS				
HU-250LP	250,000	50,000	3/4"	16 lbs.
GAS SAVER – NATURAL GAS				
HU-300PS	290,000	50,000	1/2"	18 lbs.

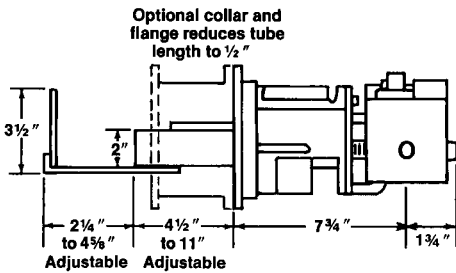

HA Left Side

Model	BTU/Hr. Input		Gas Pipe Connection	Approximate Shipping Wt.
	Maximum	Minimum		
NATURAL GAS				
HA-300	290,000	50,000	3/4"	16 lbs.
GAS SAVER – NATURAL GAS				
HA-300PS	290,000	50,000	1/2"	18 lbs.

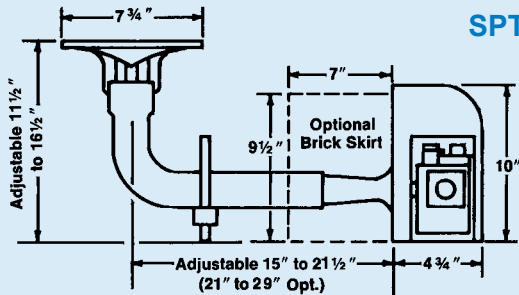

SPT Left Side

Model	BTU/Hr. Input		Gas Pipe Connection	Approximate Shipping Wt.
	Maximum	Minimum		
NATURAL GAS				
SPT-300	290,000	50,000	3/4"	18 lbs.
SPT-350	350,000	50,000	3/4"	19 lbs.
PROPANE GAS				
SPT-400LP	400,000	50,000	3/4"	18 lbs.
GAS SAVER – NATURAL GAS				
SPT-300PS	290,000	50,000	1/2"	20 lbs.

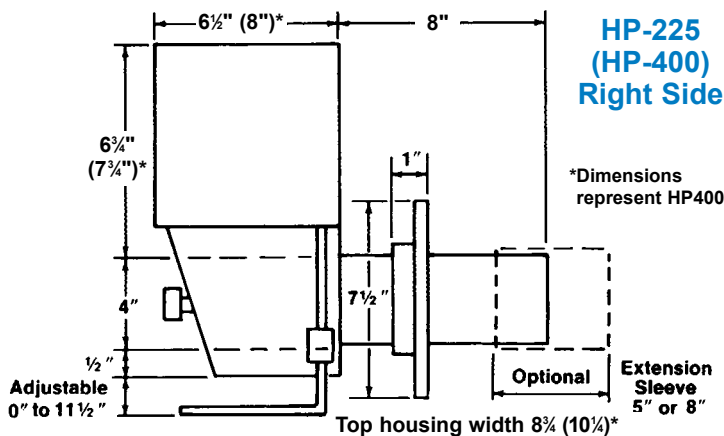

**HP-225
(HP-400)
Right Side**

Model	BTU/Hr. Input		Gas Pipe Connection	Approximate Shipping Wt.
	Maximum	Minimum		
NATURAL GAS				
HP-225	225,000	50,000	3/4"	26 lbs.
HP-225BPS	225,000	50,000	1/2"	26 lbs.
HP-400	400,000	100,000	3/4"	31 lbs.
HP-400BPS	400,000	100,000	3/4"	31 lbs.
LIQUEFIED PETROLEUM GAS				
HP-225LP	225,000	50,000	3/4"	26 lbs.
HP-225LPPS	225,000	50,000	1/2"	26 lbs.
HP-400LP	400,000	100,000	3/4"	30 lbs.
HP-400LPPS	400,000	100,000	1/2"	31 lbs.

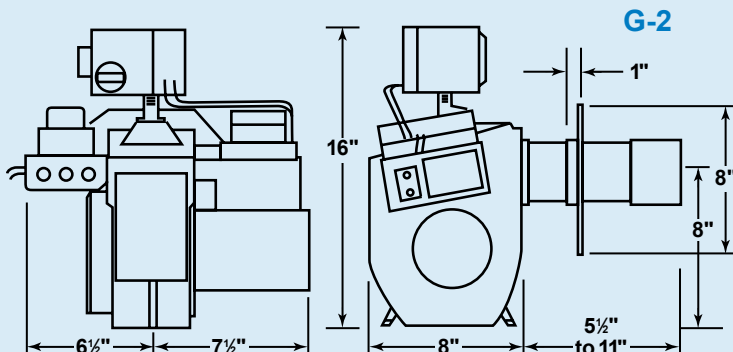

G-2

Model	BTU/Hr. Input		Gas Pipe Connection	Approximate Shipping Wt.
	Maximum	Minimum		
NATURAL OR PROPANE GAS				
G-2T	240,000	50,000	1/2"	35 lbs.
G-2SD	255,000	70,000	1/2"	34 lbs.

FORCED DRAFT GAS BURNERS

HP SERIES FORCED DRAFT CAPACITIES THRU 3,000,000 B.T.U.

Short flame for best performance in all applications. Fires into long combustion chambers but also into shortest chambers. Increases efficiency.

Vacuum mixing method (Patent No. 3589845). Eliminates pulsation or "lifting"

Quieter operation. Smoother lightoff.

Adjustable input with regulator located in the gas valve.

Flange or pedestal mounting.

U.L. listed with Honeywell or Fireye controls. Controls to meet F.M., I.R.I. (F.I.A.) or special local codes also available.

1/3 H.P. 3450 R.P.M. Motor to HP-1000

1/2 H.P. 3450 R.P.M. Motor on HP-1500

3/4 H.P. 3450 R.P.M. Motor on HP-2500 and HP-3500

Low gas pressure design. Requires only 2.0"- 5.0" W.C. pressure. Eliminates need for elevated pressure.



Bottom mounted blower HP-2500 and HP-3500 (optional).

Flange HP-800, 1000 (1500)

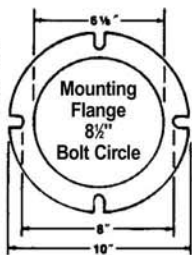

Flange HP-2500 HP-3500

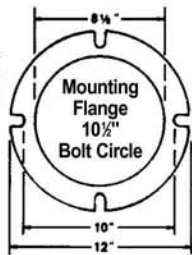

Model	BTU/Hr. Input		Gas Pipe Connection	Approximate Shipping Wt.
	Maximum	Minimum		
NATURAL GAS				
HP-800	800,000	300,000	1"	80 lbs.
HP-1000	1,000,000	300,000	1 1/4"	95 lbs.
HP-1500	1,700,000	500,000	1 1/4"	98 lbs.
LIQUEFIED PETROLEUM GAS				
HP-1000LP	1,000,000	300,000	1"	82 lbs.
HP-1500LP	1,700,000	500,000	1"	95 lbs.
NATURAL GAS				
HP-2500	2,500,000	1,000,000	2"	155 lbs.
HP-3500	3,500,000	1,000,000	2"	181 lbs.
LIQUEFIED PETROLEUM GAS				
HP-2500LP	2,500,000	1,000,000	1 1/4"	120 lbs.

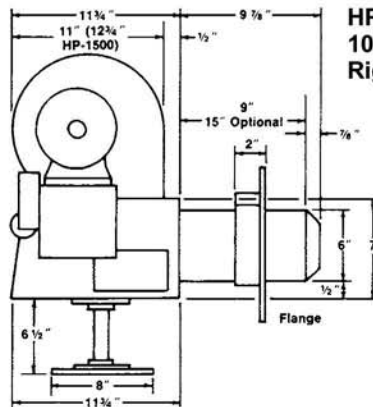

HP-800
1000 (1500)
Right Side

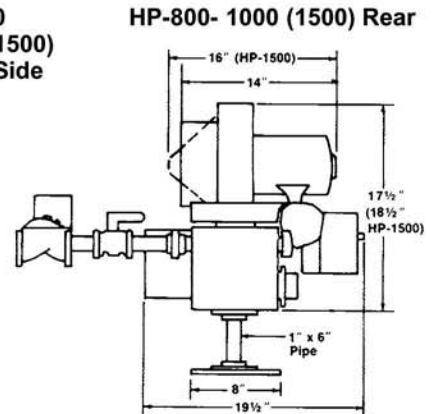

HP-800- 1000 (1500) Rear

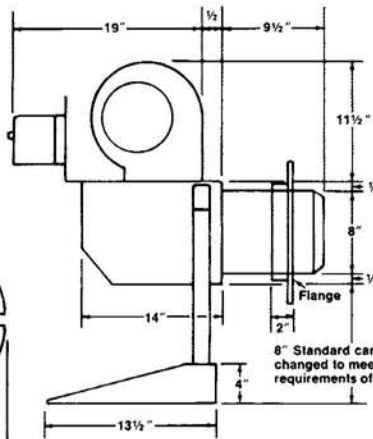

HP-2500
HP-3500
Right Side

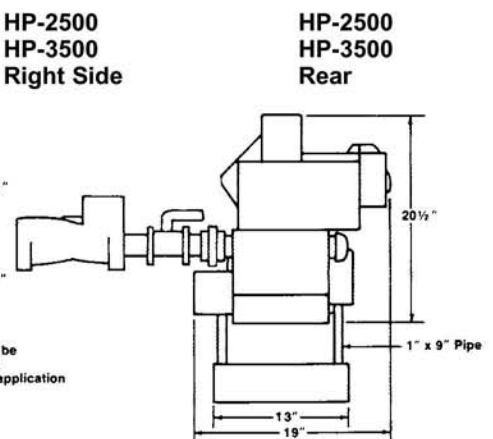

HP-2500
HP-3500
Rear

ADAMS

Manufacturing Company

9790 Midwest Ave. • Cleveland, Ohio 44125

Telephone (216) 587-6801

FAX (216) 587-6807



Distributed by