

This Owner's Manual is provided and hosted by [Appliance Factory Parts](#).



MAYTAG ESG9900 Owner's Manual

[Shop genuine replacement parts for MAYTAG ESG9900](#)

TUMBLER, TUMBLER FRONT & TUMBLER BACK

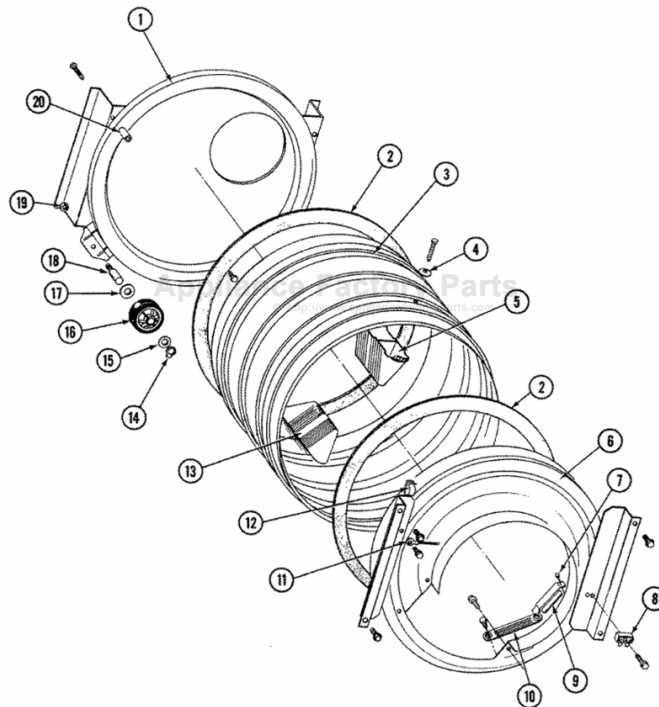

[Find Your MAYTAG Washer Parts - Select From 1759 Models](#)

----- Manual continues below part list -----

Available Replacement Parts for MAYTAG ESG9900

WP303396	G22095 THERMOSTAT AFTERMARKET
WP303395	303395 THERMOSTAT AFTERMARKET
214765	GASKET AFTERMARKET
WP314820	SEAL- TUMB DR
312535	WASHER DR AFTERMARKET
306508	KIT-BEARNG AW AFTERMARKET
306436	LATCH-DOOR DR
211100	NLA 08/18 AUTO FIBERWASHR
211047	USE WP6-2110472 NUT- CLAMP AW
210684	USE WP210684 PAD DR
203956	KIT-DAMPER DR
WP211232	SEAL DR
6-2095720	MOUNTING S AW AFTERMARKET
WP213045	DRAIN HOSE DR
WP6-2008160	PULLEY-MOTOR **new**
WP6-3033630	IDLER ARM AW
WPY312901	SEAL- BLOW DR
525	FILL VALVE CW151

STACK LAUNDRY

Repair Parts List

MODEL NUMBER

ESG9900

When requesting service or ordering parts, always provide the following information:

- Product Type
- Part Number
- Model Number
- Part Description

MAYTAG®

©2005 Maytag Services

Section: TUMBLER (FRONT & BACK)

Model: ESG9900

SECTION: TUMBLER, TUMBLER FRONT & TUMBLER BACK
MODEL: SE-SG9900

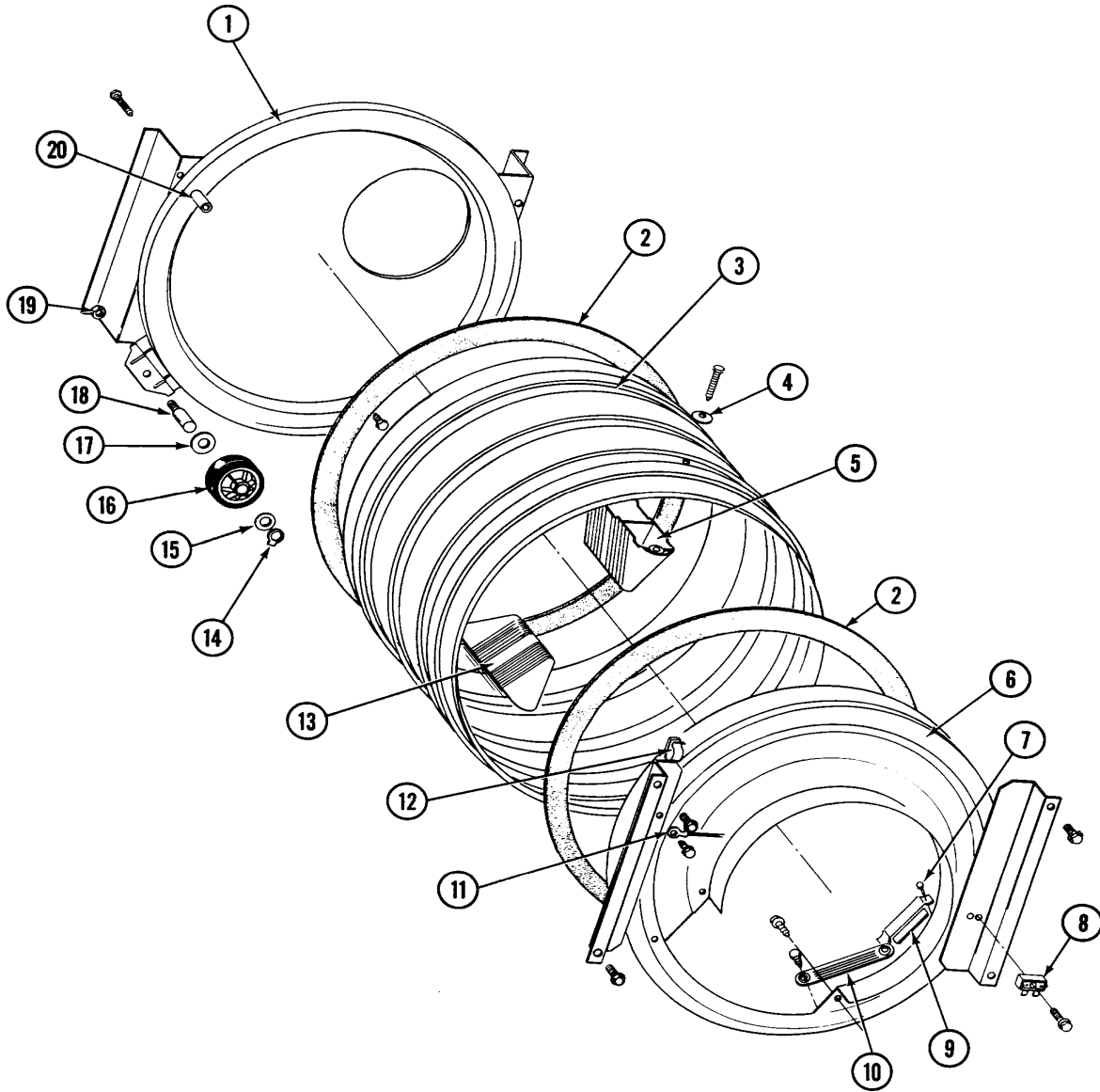

Issue Date: 8/90

Section: TUMBLER (FRONT & BACK)

No.	Part No.	Description	Series	Qty
-	N 313764	SCREW	00	4
1	306660	TUMBLER BACK Note: BACK, TUMBLER	00	1
2	314820	SEAL, TUMBLER	00	2
3	306664	TUMBLER COMPLETE Note: TUMBLER (COMPLETE)	00	1
3	314805	TUMBLER, W/RIBS W/O BAFFLES Note: TUMBLER (COMPLETE)	00	1
-	310759	SCREW	00	6
4	314158	WASHER	00	6
5	N 314807	TUMBLER BAFFLE - TALL Note: BAFFLE, TUMBLER (TALL)	00	2
-	310759	SCREW	00	6
-	N 313561	SCREW----NA Note: SCREW, INLET DUCT	00	1
-	314110	SCREW, INLET DUCT	00	4
6	306710	TUMBLER FRONT ASSEMBLY	00	1
-	310632	SCREW Note: SCREW, INLET DUCT	00	3
7	210720	RIVET	00	4
-	N 314554	SCREW	00	1
8	306130	SPARK GAP ASSEMBLY	00	1
9	306508	TUMBLER BEARING KIT	00	2
-	251119	SCREW	00	2
10	304997	SENSOR ASSEMBLY WITH SCREWS Note: SENSOR ASSEMBLY (W/SCREWS)	00	1
-	211294	SCREW	00	1
11	901220	WIRE, GROUND Note: GROUND WIRE	00	1
12	310376	CLIP, WIRE HARNESS	00	1
-	310759	SCREW	00	1
13	314806	TUMBLER BAFFLE - SHORT Note: BAFFLE, TUMBLER (SHORT)	00	1
14	410233	RING, RETAINING	00	2
15	312535	WASHER, ROLLER SHAFT	00	2
16	303373	BEARING & ROLLER ASSEMBLY Note: ROLLER (W/BEARING)	00	2
17	313347	WASHER, SPRING (ROLLER SHAFT) Note: WASHER, SPRING	00	2
18	312948	SHAFT, TUMBLER ROLLER	00	2
19	312538	NUT, ROLLER SHAFT	00	2
20	N 313915	COVER, THREAD	00	4

*Color Code (-)=Not Shown #=Series, Serial Prefix or Run No., N=Not Available

Section: INLET DUCT & HEATER ASSEMBLY (SE9900)

Model: ESG9900

SECTION: INLET DUCT & HEATER ASSEMBLY

MODEL: SE-SG9900

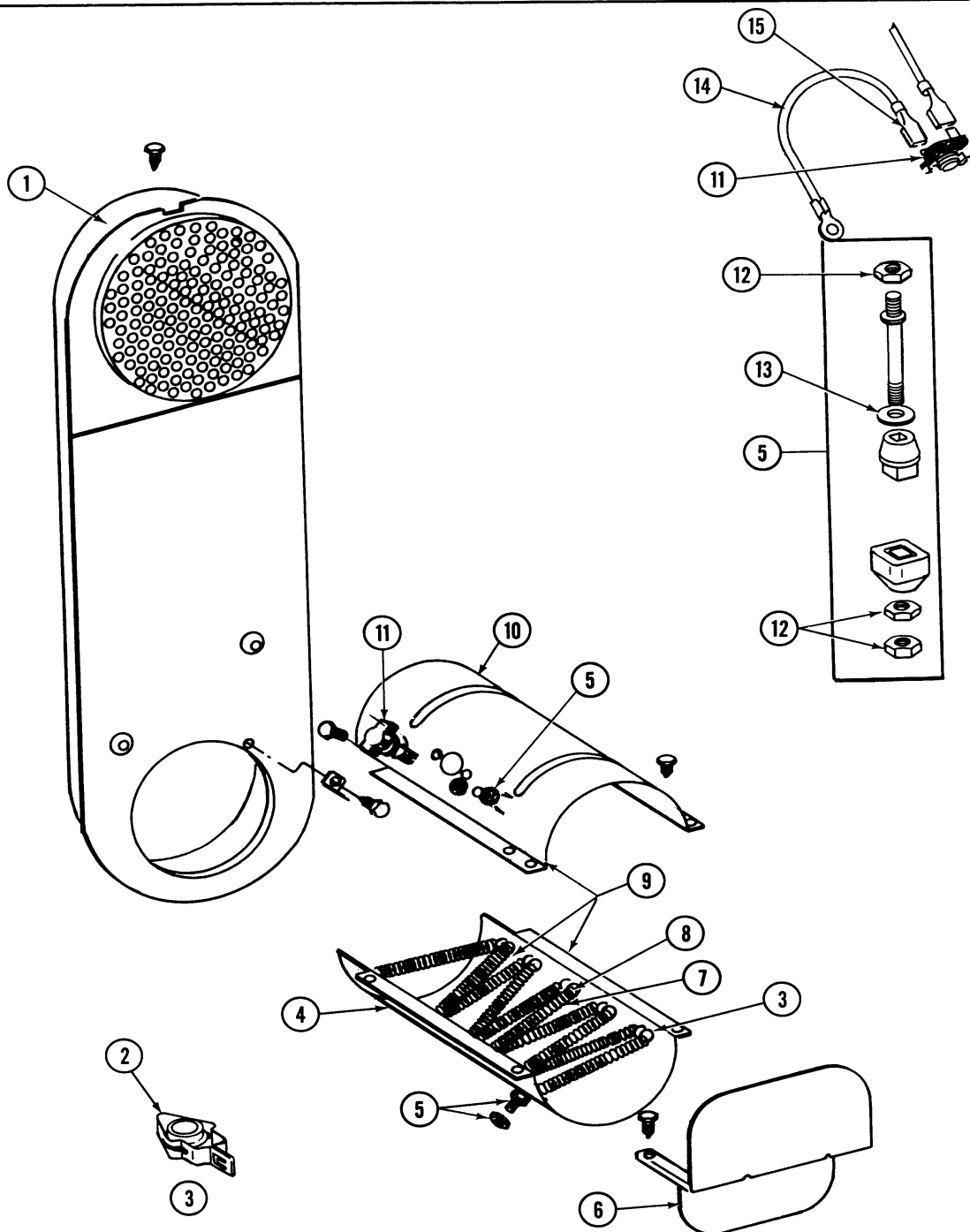

Issue Date: 8/90

18

MA55F1

Section: INLET DUCT & HEATER ASSEMBLY (SE9900)

No.	Part No.	Description	Series	Qty
1	303362	INLET DUCT ASSEMBLY - DE Note: INLET DUCT ASSEMBLY	00	1
2	313270	INSULATOR FOR HEATER ELEMEN Note: INSULATOR, HEATER ELEMENT	00	15
3	303881	CLIP AND INSULATOR ASSEMBLY Note: CLIP & INSULATOR ASSEMBLY	00	15
4	314501	HEATER ENCLOSURE-BOTTOM Note: ENCLOSURE, HEATER (BOTTOM)	00	1
-	211294	SCREW	00	1
5	304596	TERMINAL INSULATOR ASSEMBLY	00	2
-	211294	SCREW	00	2
6	314504	RADIANT SHIELD Note: SHIELD, RADIANT	00	1
7	314503	HEATER COIL 240 VOLT Note: COIL, HEATER (240V)	00	1
8	N 306378	HEATING ELEMENT KIT - 208V Note: HEATING ELEMENT KIT (208V)	00	1
9	306111	HEATER ASSEMBLY COMPLETE Note: HEATER ASSEMBLY (COMPLETE)	00	1
9	306379	HEATER ASSM. COMPLETE - 208 Note: (COMPLETE-208V)	00	1
10	N 314502	HEATER ENCLOSURE-TOP Note: ENCLOSURE, HEATER (TOP)	00	1
11	303396	THERMOSTAT, HI-LIMIT (ELEC)	00	1
-	211294	SCREW	00	2
11	303896	HI-LIMIT THERMOSTAT-CANADA Note: (CANADA)	00	1
12	311484	NUT, TERMINAL BLOCK	00	6
13	311093	WASHER, 7/32 INCH Note: WASHER (7/32")	00	2
14	304693	JUMPER WIRE Note: WIRE, JUMPER	00	1
15	210745	WIRE TERMINAL Note: TERMINAL, WIRE	00	1

*Color Code (-)=Not Shown #=Series, Serial Prefix or Run No., N=Not Available

Section: BASE, PUMP, MOTOR & COMPONENTS

No.	Part No.	Description	Series	Qty
1	215098	SHIELD, MOTOR	00	1
2	213100	BRACE, TUB	00	3
3	206707	TRANSMISSION, ORBITAL	00	1
4	211028	DEFLECTOR, WATER (DRIVE TUBE) Note: DEFLECTOR, WATER	00	1
5	203725	DAMPER W/BOLT & CLIP Note: DAMPER (W/BOLT & CLIP)	00	1
6	203956	DAMPER PAD KIT (W/POLY LUBE) Note: DAMPER PAD KIT (W/POLY LUBE)	00	1
7	N 205133	MOTOR EXTERNAL START SWITCH Note: SWITCH, MOTOR EXTERNAL START W/PROD. #2-1664-8, 2-5463	00	1
7	206505	SWITCH, MOTOR START Note: SWITCH, MOTOR EXTERNAL START W/PROD.#2-1664-11,2-5463-1	00	1
7	205132	SWITCH, MOTOR START Note: SWITCH, MOTOR EXTERNAL START W/PROD.#2-1664-4,2-1664-98, 2-1664-12, & 2-5463-2	00	1
8	201805	MOTOR (ONE SPEED)	00	1
9	210385	NUT, LOCK	00	4
10	302699	LEG, ADJUSTABLE (W/NUT)	00	4
11	210684	FOOT, RUBBER	00	4
12	214956	MOUNT, MOTOR/UPPER Note: PLATE, MOTOR MOUNT (UPR)	00	1
13	205999	MOTOR MOUNT ASSM COMPLETE Note: MOTOR MOUNT ASSY. (COMPLETE)	00	1
14	202718	TENSION SPRINGS Note: SPRINGS, TENSION	00	2
15	204998	GLIDE KIT (4 W/POLY LUBE) Note: GLIDE KIT (4 W/POLY LUBE)	00	1
16	205908	LOWER MOTOR MOUNT Note: MOUNT, MOTOR (LOWER)	00	1
17	311426	NUT, WASHERED LOCK Note: KEPS NUT, MOTOR BASE	00	3
18	200816	PULLEY, MOTOR (W/SET SCREW)	00	1
-	053241	SET SCREW, PULLEY	00	1
19	205000	GLIDE & SPRING KIT	00	1
20	203274	BASE WITH DAMPER PADS Note: BASE (W/DAMPER PADS)	00	1
21	901220	WIRE, GROUND Note: GROUND WIRE	00	1
-	210186	SCREW, GROUND WIRE TO BASE--NA	00	1
22	215365	HOSE	00	1
23	200461	HOSE CLAMP - 1-5/8 INCH Note: CLAMP, HOSE (1-5/8")	00	1
-	015408	SCREW, BEARING INSERT	00	1
24	202203	PUMP AS PAK	00	1
-	211880	SCREW, HEX HD #10 X 1/2 INC Note: SCREW (HEX HD #10 X 1/2")	00	3
25	202574	CLAMP, HOSE	00	1
26	213045	DRAIN HOSE-TUB TO PUMP Note: HOSE, OUTER TUB	00	1
27	211949	NUT, EYEBOLT	00	3
28	213120	EYE BOLT FOR CENTER SPRING Note: EYE BOLT, CENTER SPRING	00	3
29	015627	SCREW, HEX HD CAP 5/16 X 5/8	00	6
30	911852	WASHER, LOCK (BRACE)	00	6
31	213054	CENTERING SPRING - 3 USED Note: SPRING, CENTERING	00	3
32	213073	WASHER, DOUBLE Note: WASHER, DOUBLE	00	3
33	052785	NUT, BRACE TO DAMPER Note: NUT, BRACE TO DAMPER	00	6
34	052734	NUT Note: NUT, BRACE TO TUB	00	3
35	054867	WASHER, LOCK	00	3
36	212979	WASHER, TUB BRACE	00	6
37	211100	WASHER, CUSHION	00	3
38	054867	WASHER, LOCK	00	3
39	205254	BOLT & GASKET ASSEMBLY (LONG) Note: (LONG)	00	2
39	200744	BOLT & GASKET ASSY.(SHORT) Note: BOLT & GASKET ASSY. (SHORT)	00	1

*Color Code (-)=Not Shown #=Series, Serial Prefix or Run No., N=Not Available

Section: FRONT VIEW (ESE9900 & ESG9900)

Model: ESG9900

SECTION: FRONT VIEW
MODEL: ESE9900 - ESG9900

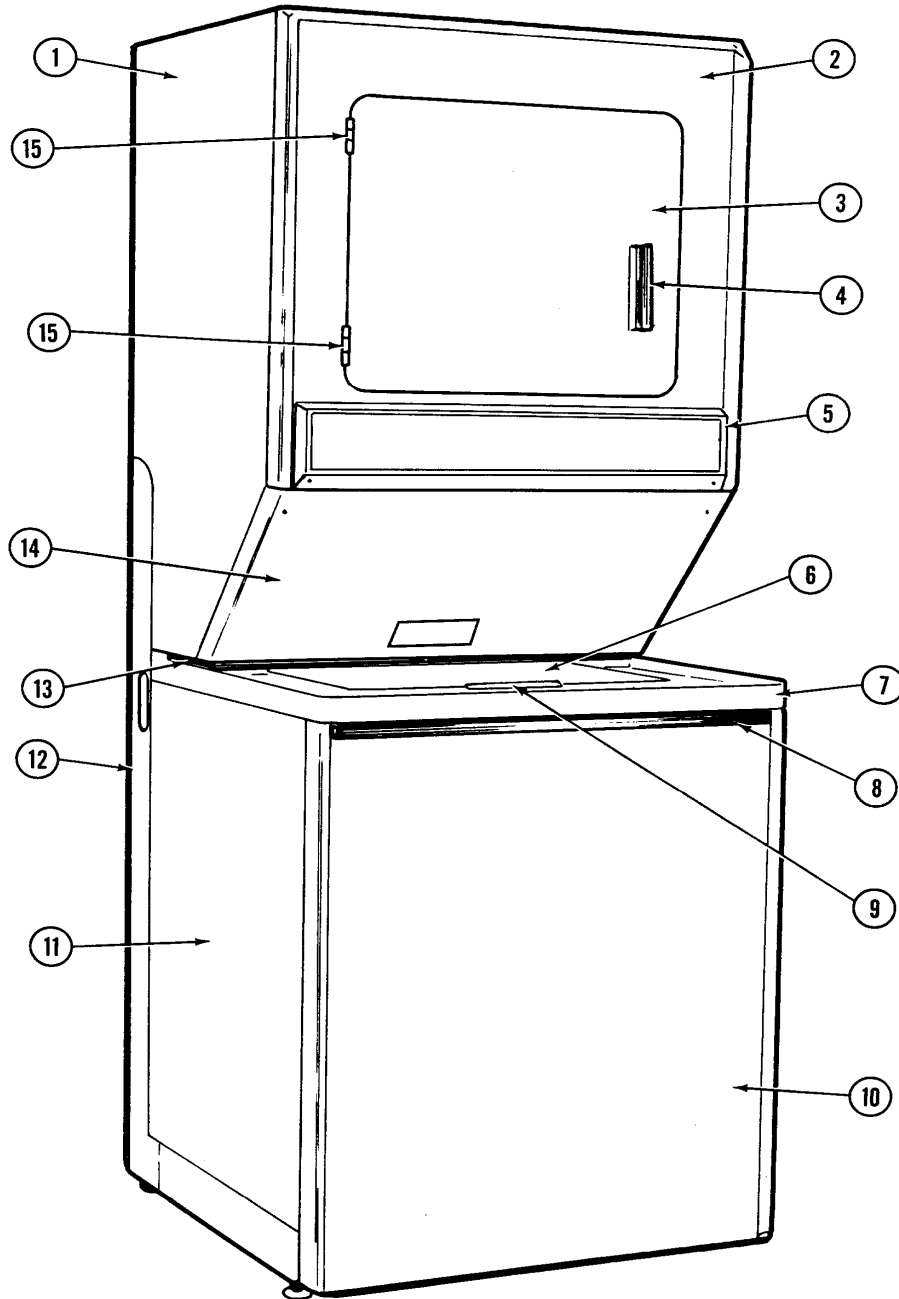

Issue Date: 1/91

Section: FRONT VIEW (ESE9900 & ESG9900)

No.	Part No.	Description	Series	Qty
1	N 308055	CABINET (WHT)	00	1
2	N 314474	FRONT PANEL-WHITE Note: PANEL, FRONT (WHT)	00	1
3	314475	PANEL, OUTER DOOR (WHT)	00	1
4	314476	HANDLE,DOOR Note: HANDLE, DOOR	00	1
-	210932	SCREW, #8 X 9/16 CTSK Note: SCREW, CONTROL PANEL	00	2
5	N 307966	CONTROL PANEL Note: PANEL, CONTROL	00	1
6	215251	LID-WHITE Note: LID (WHT)	00	1
7	N 207579	TOP COVER (WHITE) Note: COVER, TOP (WHT)	00	1
8	N 215266	TRIM, FRONT PANEL	00	1
9	206667	HANDLE WITH NUTS Note: HANDLE (W/NUTS)	00	1
10	207205	PANEL, FRONT (WHT)	00	1
11	N 207207	CABINET WHT Note: CABINET (WHT)	00	1
12	306110	STAND, DRYER (COMPLETE) (WHT) Note: STAND, DRYER (COMPLETE-WHT)	00	1
13	N 215245	BRIDGE FOR TOP COVER NA Note: BRIDGE, TOP COVER	00	1
14	N 307844	ACCESS PANEL (WHT) Note: PANEL, ACCESS (WHT)	00	1
15	N 304577	DOOR HINGE Note: HINGE, DOOR	00	2

*Color Code (-)=Not Shown #=Series, Serial Prefix or Run No., N=Not Available

Section: DOOR, FRT & CNTRL PNL ESE9900 & ESG99

No.	Part No.	Description	Series	Qty
1	314286	SEAL FOR FRONT PANEL Note: SEAL, FRONT PANEL	00	1
2	N 314474	FRONT PANEL-WHITE Note: PANEL, FRONT (WHT)	00	1
-	212277	SCREW, #8 X 1/2 INCH Note: SCREW (#8 X 1/2")	00	2
3	310376	CLIP, WIRE HARNESS	00	1
4	313927	INSTRUCTION LABEL Note: LABEL, INSTRUCTION	00	1
-	312960	SCREW - INLET DUCT Note: SCREW, INLET DUCT	00	1
5	306436	DOOR LATCH KIT	00	1
6	314609	CAUTION LABEL Note: LABEL, CAUTION	00	1
7	N 307856	WIRE HARNESS, MAIN (SG9900) Note: WIRE HARNESS (UPPER-GAS)	00	1
7	910768	CABLE STRAP-HARNESS TO BASE Note: STRAP, CABLE	00	1
7	N 306717	CNT. HARNESS MICROPROCESSOR Note: WIRE HARNESS, MICROPROCESSOR	00	1
7	N 307852	WIRE HARNESS, MAIN (SE9900) Note: WIRE HARNESS (UPPER-ELE.)	00	1
7	N 307854	WIRE HARNESS, MAIN (SE9900 CAN Note: WIRE HARNESS (UPPER-CAN-ELEC.)	00	1
7	N 312953	RECEPTACLE	00	23
8	N 314523	CLIP	00	1
-	212949	SCREW	00	1
9	306070	SPEAKER	00	1
10	912086	CLIP,SPEED Note: CLIP, SPEED	00	1
11	N 314561	AIR SEAL Note: SEAL, AIR	00	1
-	210932	SCREW, #8 X 9/16 CTSK Note: SCREW, CONTROL PANEL	00	2
12	N 307966	CONTROL PANEL Note: PANEL, CONTROL	00	1
13	N 314560	SEAL, MOISTURE	00	1
14	307965	TOUCHPAD WITH BRACKET Note: TOUCHPAD (W/BRACKET)	00	1
-	211294	SCREW	00	3
15	306069	CONTROL ASSEMBLY Note: CONTROL ASSEMBLY	00	1
16	912075	CIRCUIT BOARD SPACER Note: SPACER, CIRCUIT BOARD	00	6
17	912077	LOCKNUT	00	6
18	314482	FASTENER, SPRING	00	2
-	211294	SCREW	00	2
19	N 314481	MOUNTING BRACKET Note: BRACKET, MOUNTING	00	2
20	314748	NUT	00	2
21	N 314517	SHIELD FOR MICROPROCESSOR Note: SHIELD, MICROPROCESSOR	00	1
22	N 314486	LABEL	00	1
23	305753	SWITCH, DOOR	00	1
24	314475	PANEL, OUTER DOOR (WHT)	00	1
25	313910	CLIP, DOOR LINER TO OUTER PNL Note: CLIP, DOOR LINER	00	6
-	314062	SCREW	00	8
26	N 304577	DOOR HINGE Note: HINGE, DOOR	00	2
27	N 306676	INNER DOOR WITH KNOB Note: DOOR, INNER (W/KNOB)	00	1
28	314077	DOOR SEAL Note: SEAL, DOOR	00	1
29	313911	DOOR STRIKE RETAINER Note: RETAINER, DOOR STRIKE	00	1
30	214872	PALNUT, END CAP	00	1
31	314476	HANDLE,DOOR Note: HANDLE, DOOR	00	1

*Color Code (-)=Not Shown #=Series, Serial Prefix or Run No., N=Not Available

Section: CABINET, RELAYS (ESE9900 & ESG9900)

Model: ESG9900

SECTION: CABINET, RELAYS & DRYER STAND
 MODEL: ESE9900 - ESG9900

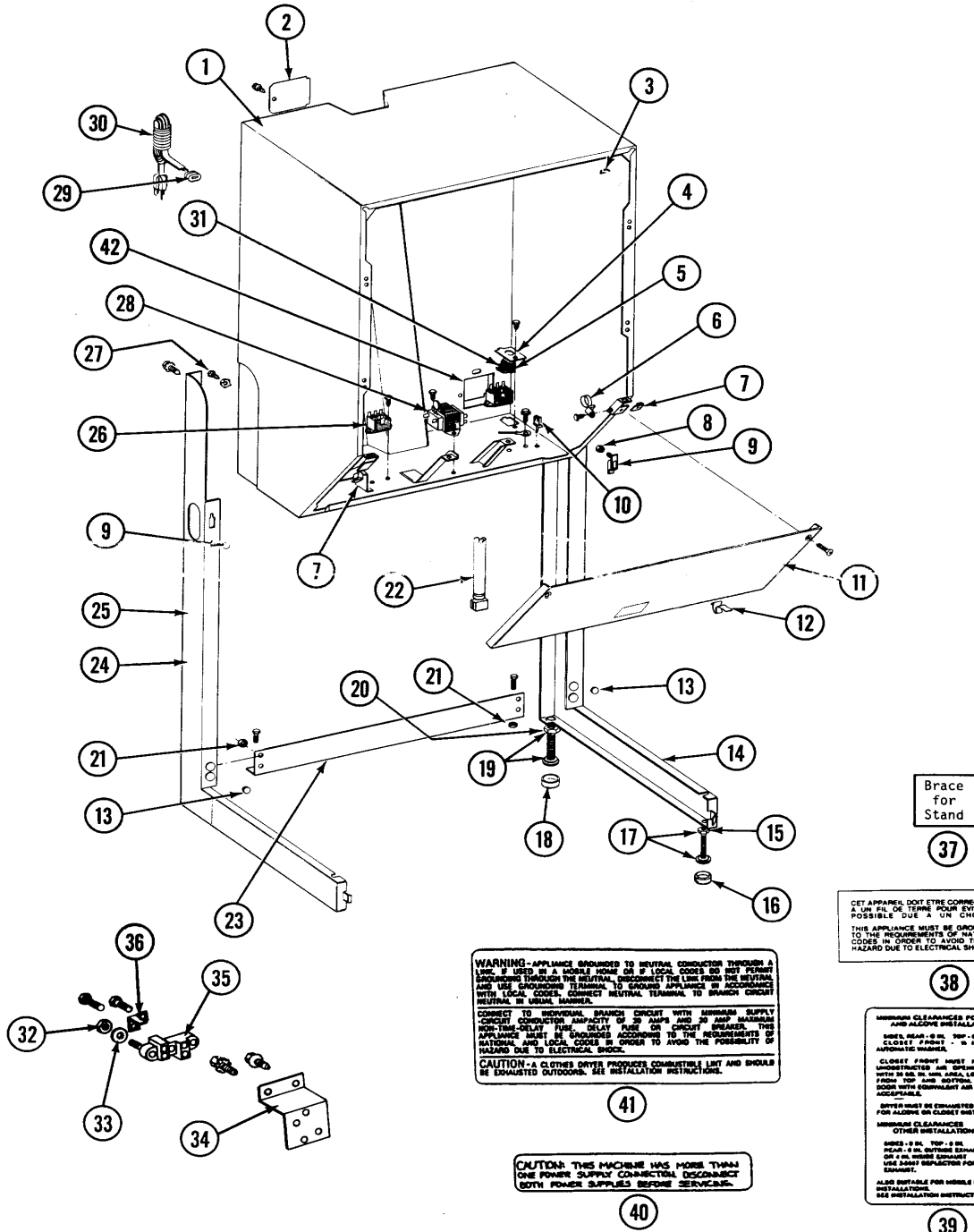

Brace for Stand
37

CET APPAREIL DOIT ETRE CORRECTEMENT BRANCHE A UN FIL DE TERRE POUR EVITER TOUT DANGER POSSIBLE DUE A UN CHOC ELECTRIQUE.
 THIS APPLIANCE MUST BE GROUNDED ACCORDING TO THE REQUIREMENTS OF NATIONAL AND LOCAL CODES IN ORDER TO AVOID THE POSSIBILITY OF HAZARD DUE TO ELECTRICAL SHOCK.

38

MINIMUM CLEARANCES FOR CLOSET AND ABOVE INSTALLATIONS
 6 IN. REAR - 6 IN. TOP - 6 IN. CLOSED CIRCUIT - 9 IN. FROM AUTOMATIC SWITCHES
 CLOSET FRONT MUST HAVE TWO UNOBSTRUCTED AIR OPENINGS, EACH WITH 20 IN. DIAM. LATERAL 1/2 IN. FROM TOP AND BOTTOM. LOWERED DOOR WITH EQUIVALENT AIR OPENING IS ACCEPTABLE.
 DRYER MUST BE DAMAGED TO BE OUTSIDE FOR ABOVE OR CLOSET INSTALLATION.
 MINIMUM CLEARANCES OTHER INSTALLATIONS
 6 IN. - 6 IN. TOP - 6 IN. REAR - 6 IN. FROM EXHAUST OR 4 IN. FROM EXHAUST AND SHIRT REFLECTOR FOR RANGE EXHAUST.
 ALSO SUITABLE FOR MOBILE HOME INSTALLATIONS. SEE INSTALLATION INSTRUCTIONS.

39

WARNING-APPLIANCE BRANCHED TO NEUTRAL CONDUCTOR THROUGH A SW. IS USED IN A MOBILE HOME OR LOCAL CODES DO NOT PERMIT BRANCHED THROUGH THE NEUTRAL. DISCONNECT THE LINE FROM THE NEUTRAL AND USE BRANCHED TERMINAL TO GROUND APPLIANCE IN ACCORDANCE WITH LOCAL CODES. CONNECT NEUTRAL TERMINAL TO BRANCH CIRCUIT NEUTRAL IN MOBILE HOMES.
 CONNECT TO INDIVIDUAL BRANCHED CIRCUIT WITH MINIMUM SUPPLY CIRCUIT CONDUCTOR CAPACITY OF 20 AMP AND 20 AMP MAXIMUM NON-TIME-DELAY FUSE, DELAY FUSE OR CIRCUIT BREAKER. THIS APPLIANCE MUST BE GROUNDED ACCORDING TO THE REQUIREMENTS OF NATIONAL AND LOCAL CODES IN ORDER TO AVOID THE POSSIBILITY OF HAZARD DUE TO ELECTRICAL SHOCK.
CAUTION-A CLOTHES DRYER PROVIDES COMMITTEE LIT AND SHOULD BE EXHAUSTED OUTDOORS. SEE INSTALLATION INSTRUCTIONS.

41

CAUTION-THIS MACHINE HAS MORE THAN ONE POWER SUPPLY CONNECTION. DISCONNECT BOTH POWER SUPPLIES BEFORE SERVICING.

40

Issue Date: 1/91

Section: CABINET, RELAYS (ESE9900 & ESG9900)

No.	Part No.	Description	Series	Qty
1	N 308055	CABINET (WHT)	00	1
-	N 313561	SCREW----NA	00	1
2	314470	COVER, TERMINAL	00	1
3	312548	FASTENER-ACCESS PANEL TO CA Note: FASTENER, ACCESS PANEL	00	2
4	N 314532	MOUNTING BRACKET Note: BRACKET, MOUNTING	00	1
-	211168	SCREW, #8 X 5/16 INCH Note: SCREW (#8 X 5/16")	00	1
5	901961	RELAY (4 CONTACT) Note: RELAY, HEATER	00	1
-	251119	SCREW	00	1
6	212458	WIRE RETAINER-PLASTIC Note: WIRE RETAINER (PLASTIC)	00	1
-	310632	SCREW	00	1
7	215075	FASTENER,CNTRL PNL TO CONSOLE Note: FASTENER, CONTROL PANEL	00	2
8	214872	PALNUT, END CAP	00	1
9	314489	GUIDE, PIN	00	1
10	N 313262	RETAINER, WIRE HARNESS	00	4
-	314477	SCREW, ACCESS PANEL	00	2
11	N 307844	ACCESS PANEL (WHT) Note: PANEL, ACCESS (WHT)	00	1
12	314482	FASTENER, SPRING	00	2
13	314498	PAD, DRYER LEG	00	3
14	306073	LEG ASSM, (RT-WHT) Note: LEG ASSEMBLY (RT-WHT)	00	1
15	052740	NUT	00	2
16	314137	FOOT, RUBBER	00	2
17	305086	ADJUSTABLE LEG & NUT	00	2
18	210684	FOOT, RUBBER	00	2
19	302699	LEG, ADJUSTABLE (W/NUT)	00	2
20	210385	NUT, LOCK	00	2
21	052721	NUT	00	4
22	N 306717	CNT. HARNESS MICROPROCESSOR Note: WIRE HARNESS, MICROPROCESSOR	00	1
-	214354	SCREW	00	2
23	N 314499	BRACE	00	1
24	N 306074	LEG ASSM, LEFT-WHITE Note: LEG ASSEMBLY (LT-WHT)	00	1
25	306110	STAND, DRYER (COMPLETE) (WHT) Note: STAND, DRYER (COMPLETE-WHT)	00	1
-	314663	SCREW	00	4
26	901961	RELAY (4 CONTACT)	00	1
-	251119	SCREW	00	1
27	303846	SCREW & WASHER ASSY. Note: SCREW & WASHER ASSEMBLY	00	1
28	306062	TRANSFORMER	00	1
-	212276	SCREW	00	1
29	N 314507	STRAIN RELIEF Note: RELIEF, STRAIN	00	1
30	302521	POWER CORD Note: CORD, POWER	00	1
30	305168	CORD, POWER (CANADA) Note: (CANADA)	00	1
31	314522	STRAIN RELIEF Note: RELIEF, STRAIN	00	1
-	211168	SCREW, #8 X 5/16 INCH Note: SCREW (#8 X 5/16")	00	1
32	311484	NUT, TERMINAL BLOCK Note: NUT, TERMINAL BLOCK	00	2
33	311270	WASHER, TERMINAL BLOCK	00	3
34	312904	BRACKET, TERMINAL BLOCK	00	1
-	N 313561	SCREW----NA	00	1
-	310632	SCREW	00	1
37	N 306128	BRACE FOR STAND-ACCESSORY Note: BRACE, STAND (ACCY.)	00	1
38	214519	LABEL, ELECTRICAL INSTRUCTION	00	1
39	N 314486	LABEL	00	1
40	314609	CAUTION LABEL Note: LABEL, CAUTION	00	1
41	N 314505	INSTRUCTION LABEL Note: LABEL, INSTRUCTION	00	1
-	N 313561	SCREW----NA	00	1
42	315275	TERMINAL COVER Note: COVER, TERMINAL	00	1

*Color Code (-)=Not Shown #=Series, Serial Prefix or Run No., N=Not Available

Section: ACCESS PNL & TUB LGT (ESE9900 & ESG9900)

Model: ESG9900

SECTION: ACCESS PANEL & TUB LIGHT ASSEMBLY

MODEL: ESE9900 - ESG9900

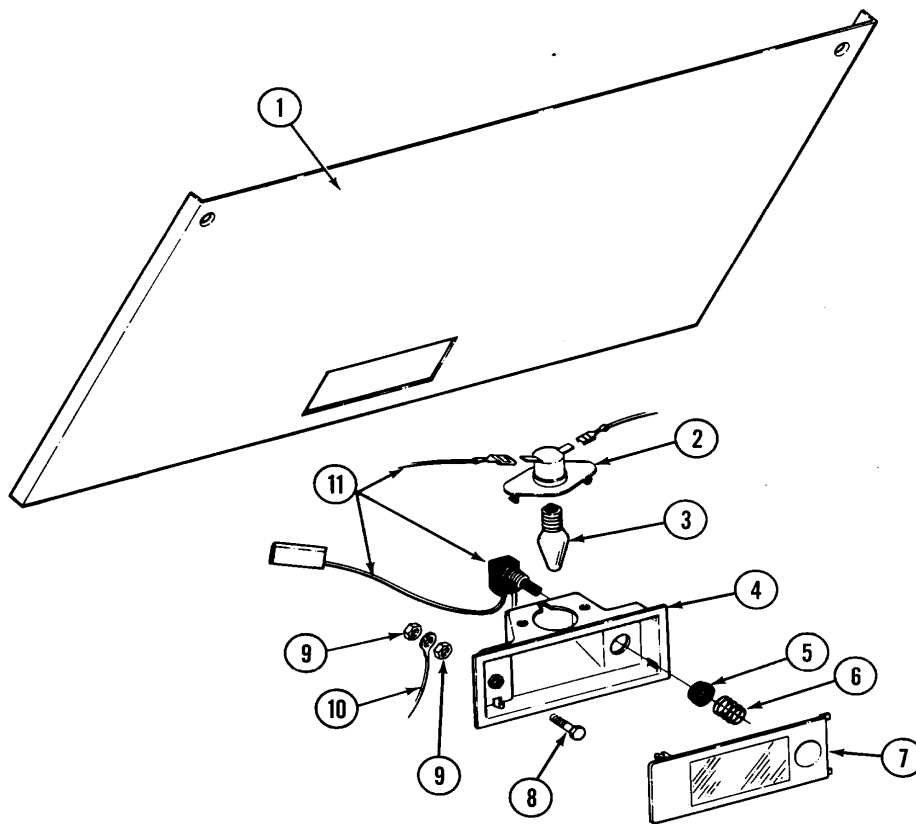

Issue Date: 1/91

10

MA87E1

Section: ACCESS PNL & TUB LGT (ESE9900 & ESG99

No.	Part No.	Description	Series	Qty
1	N 307844	ACCESS PANEL (WHT) Note: PANEL, ACCESS (WHT)	00	1
2	315198	LAMP HOLDER Note: HOLDER, LAMP	00	1
3	307100	LIGHT	00	1
4	315195	LAMP BRACKET Note: BRACKET, LAMP (WHT)	00	1
5	N 315197	NUT FOR TUB LIGHT SWITCH Note: NUT, TUB LIGHT SWITCH	00	1
6	N 315196	SPRING FOR TUB LIGHT Note: SPRING, TUB LIGHT	00	1
7	307845	LENS ASSEMBLY Note: LENS ASSEMBLY (WHT)	00	1
8	315211	SCREW Note: BOLT, LAMP BRACKET	00	1
9	912077	LOCKNUT	00	2
10	204807	GRND.WIRE,SUPP.PLTE TO TOP CVR Note: GROUND WIRE, SUPPORT PLATE	00	1
11	307847	SWITCH AND WIRE ASSEMBLY Note: SWITCH & WIRE ASSEMBLY	00	1

*Color Code (-)=Not Shown #=Series, Serial Prefix or Run No., N=Not Available

Section: TUMBLER (FRT & BACK) (ESE9900 & ESG9900)

Model: ESG9900

SECTION: TUMBLER, TUMBLER FRONT & TUMBLER BACK

MODEL: ESE9900 - ESG9900

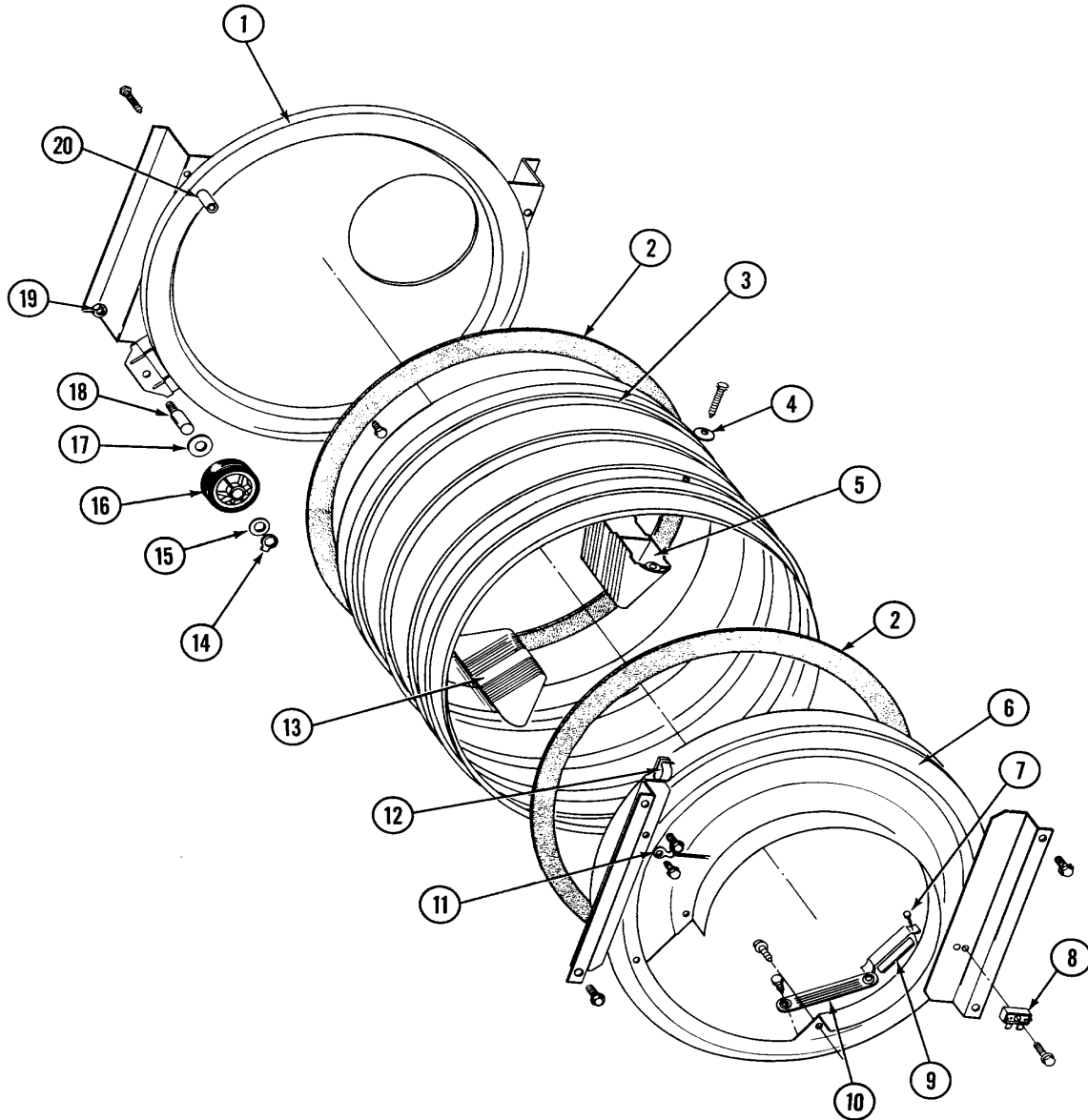

Issue Date: 1/91

12

MA87E3

Section: TUMBLER (FRT & BACK) (ESE9900 & ESG99)

No.	Part No.	Description	Series	Qty
-	211294	SCREW	00	1
1	306660	TUMBLER BACK Note: BACK, TUMBLER	00	1
- N	313764	SCREW	00	4
2	314820	SEAL, TUMBLER	00	2
-	310759	SCREW	00	6
3	314805	TUMBLER, W/RIBS W/O BAFFLES Note: TUMBLER (COMPLETE)	00	1
3	306664	TUMBLER COMPLETE Note: TUMBLER (COMPLETE)	00	1
4	314158	WASHER	00	6
5 N	314807	TUMBLER BAFFLE - TALL Note: BAFFLE, TUMBLER (TALL)	00	2
-	310759	SCREW	00	6
6	306710	TUMBLER FRONT ASSEMBLY	00	1
- N	313561	SCREW----NA Note: SCREW, INLET DUCT	00	1
-	314110	SCREW, INLET DUCT	00	4
-	310632	SCREW Note: SCREW, INLET DUCT	00	3
7	210720	RIVET	00	1
- N	314554	SCREW	00	1
8	306130	SPARK GAP ASSEMBLY	00	1
9	306508	TUMBLER BEARING KIT	00	2
10	304997	SENSOR ASSEMBLY WITH SCREWS Note: SENSOR ASSEMBLY (W/SCREWS)	00	1
-	251119	SCREW	00	2
-	211294	SCREW	00	1
11	901220	WIRE, GROUND Note: GROUND WIRE	00	1
12	310376	CLIP, WIRE HARNESS	00	1
-	310759	SCREW	00	6
13	314806	TUMBLER BAFFLE - SHORT Note: BAFFLE, TUMBLER (SHORT)	00	1
14	410233	RING, RETAINING	00	2
15	312535	WASHER, ROLLER SHAFT	00	2
16	303373	BEARING & ROLLER ASSEMBLY Note: ROLLER (W/BEARING)	00	2
17	313347	WASHER, SPRING (ROLLER SHAFT)	00	2
18	312948	SHAFT, TUMBLER ROLLER	00	2
19	312538	NUT, ROLLER SHAFT	00	2
20 N	313915	COVER, THREAD	00	4

*Color Code (-)=Not Shown #=Series, Serial Prefix or Run No., N=Not Available

Section: MOTOR & IDLER ASSY. (ESE9900 & ESG9900)

Model: ESG9900

SECTION: MOTOR & IDLER ASSEMBLY
MODEL: ESE9900 - ESG9900

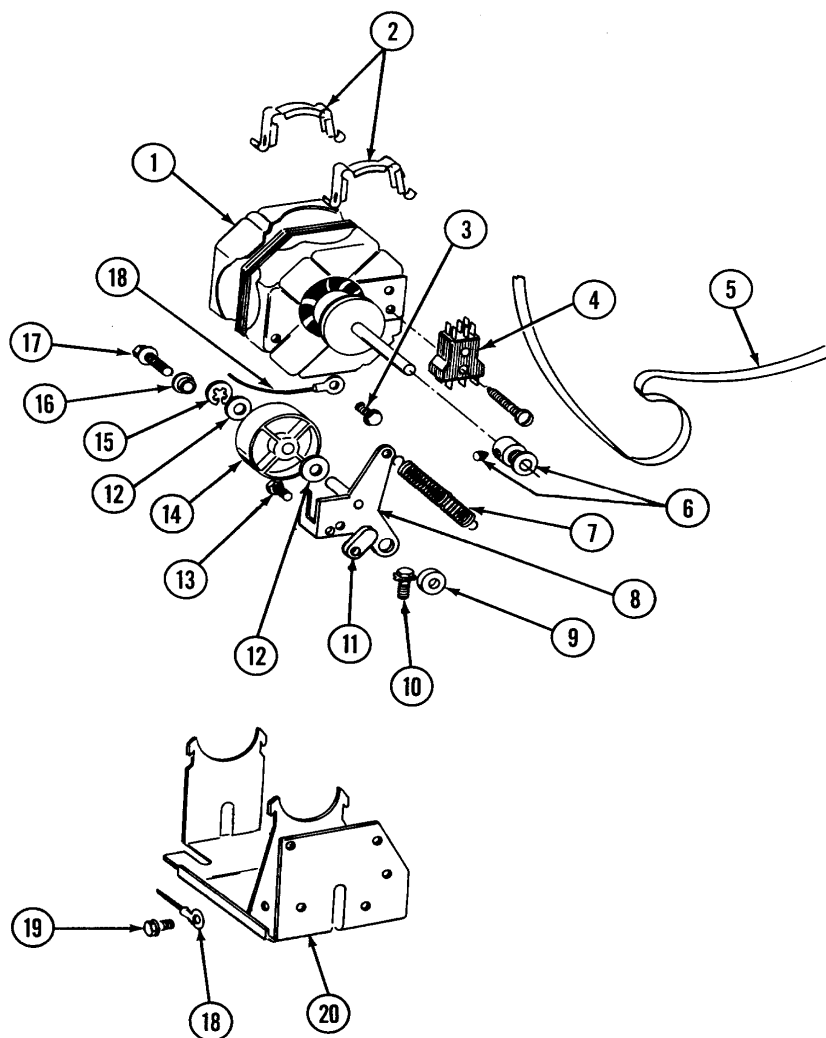

Issue Date: 1/91

14

MA87E5

Section: MOTOR & IDLER ASSY. (ESE9900 & ESG990

No.	Part No.	Description	Series	Qty
1	306055	MOTOR	00	1
2	015825	CLIP, MOTOR	00	2
3	211294	SCREW	00	1
4	303877	SWITCH, MOTOR Note: SWITCH, MOTOR EXTERNAL START (PROD.ID#3-6055-1)	00	1
4	N 306207	SWITCH, MOTOR START-PROD. Note: SWITCH, MOTOR EXTERNAL START (PROD.ID#3-6055,3-6055-2)	00	2
5	314774	BELT, DRUM	00	1
6	306099	MOTOR PULLEY WITH SET SCREW Note: MOTOR PULLEY (W/SET SCREW)	00	1
-	053241	SET SCREW, PULLEY	00	1
7	314473	SPRING FOR IDLER Note: SPRING, IDLER	00	1
8	303363	IDLER ARM & SHAFT ASSY. Note: IDLER ARM & SHAFT ASSEMBLY	00	1
9	314457	SPACER FOR IDLER ARM Note: SPACER, IDLER ARM	00	1
10	N 313561	SCREW----NA	00	2
11	314456	SPACER	00	1
12	312527	WASHER, IDLER SHAFT (QTY-1)	00	2
13	312057	SCREW,SPACER Note: SCREW, SPACER	00	1
14	303705	PULLEY, IDLER	00	1
15	312958	RETAINING RING, IDLER SHAFT	00	1
16	N 312894	SLEEVE, IDLER ARM	00	1
17	310842	SCREW	00	1
18	901220	WIRE, GROUND Note: GROUND WIRE	00	1
19	211294	SCREW	00	1
20	306054	SUPPORT, MOTOR	00	1

*Color Code (-)=Not Shown #=Series, Serial Prefix or Run No., N=Not Available

Section: BLOWER HOUSING/THERM (ESE9900 & ESG9900)

Model: ESG9900

SECTION: BLOWER HOUSING, THERMOSTATS & LINT SCREEN

MODEL: SE7800 SG7800

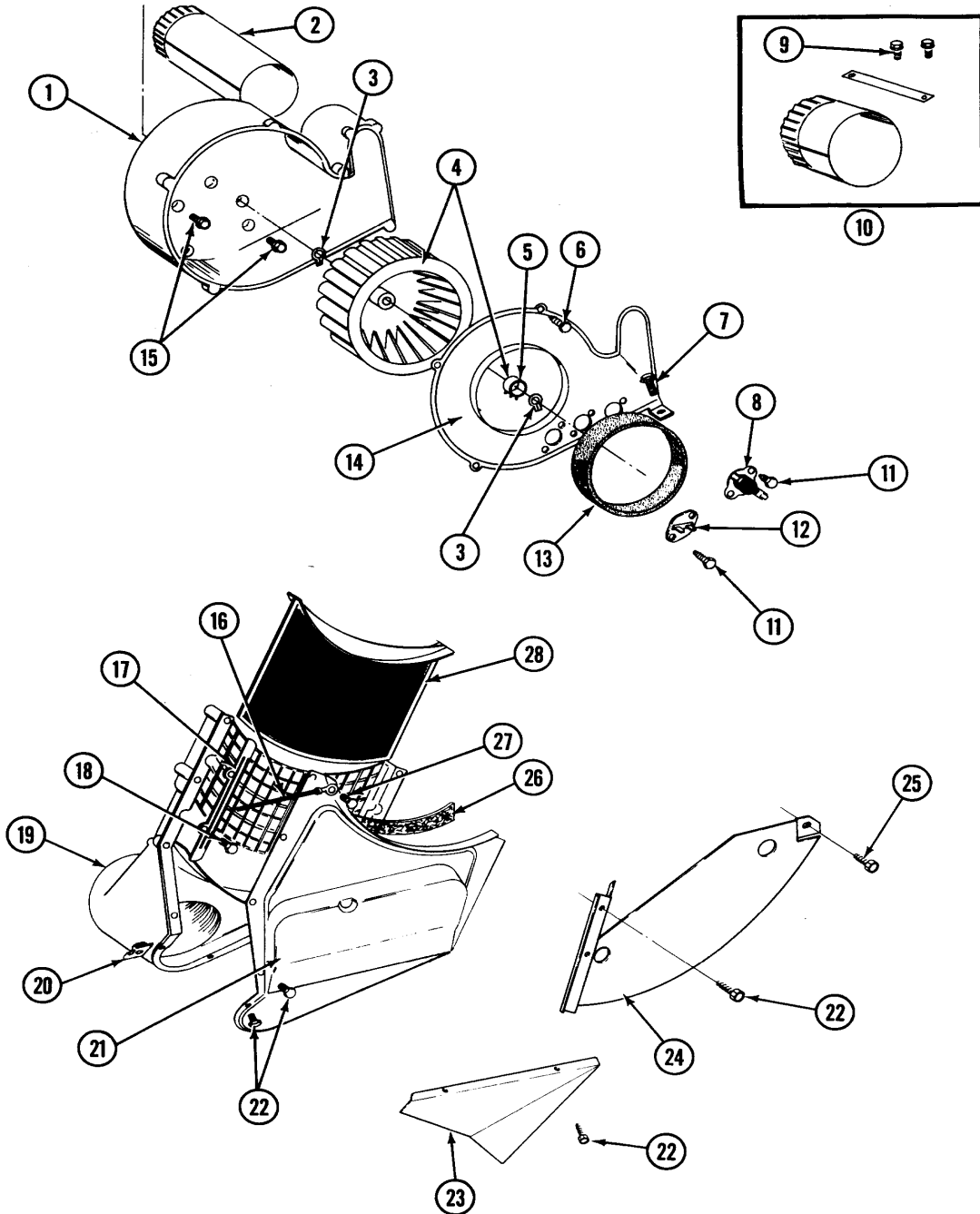

Issue Date: 12/90

16

MA87B5

Section: BLOWER HOUSING/THERM (ESE9900 & ESG)

No.	Part No.	Description	Series	Qty
1	312893	HOUSING, BLOWER	00	1
2	306637	EXHAUST DUCT ASSEMBLY	00	1
3	410233	RING, RETAINING	00	2
4	303836	BLOWER WHEEL ASSEMBLY & CLAMP Note: IMPELLER, BLOWER (W/CLAMP)	00	1
5	312967	CLAMP, BLOWER HOUSING	00	1
6	312961	SCREW	00	6
7	N 313561	SCREW----NA	00	3
8	306056	THERMISTOR TEMP CONTROL Note: TEMP. CONTROL, THERMISTOR	00	1
9	310632	SCREW	00	2
10	306643	DUCT W/BRACKET & SCREWS Note: EXTENSION, DUCT (W/CLIPS)	00	1
11	211294	SCREW	00	4
12	306060	THERMOSTAT	00	1
13	314848	SCREW	00	2
14	306604	CUT-OFF, THERMAL	00	1
15	312901	SEAL, BLOWER	00	1
16	314846	COVER, BLOWER HOUSING	00	1
17	310632	SCREW	00	4
18	901220	WIRE, GROUND Note: GROUND WIRE	00	1
19	313795	GUIDE FOR LINT SCREEN Note: GUIDE, LINT SCREEN	00	2
20	312961	SCREW	00	2
21	314801	OUTLET DUCT & GRID	00	1
22	315274	FASTENER ON OUTLET DUCT Note: FASTENER, OUTLET DUCT	00	3
23	314485	OUTLET DUCT AND GRID Note: OUTLET DUCT & GRID	00	1
24	312961	SCREW	00	8
25	315239	SHIELD FOR OUTLET DUCT	00	1
26	313796	LINT SEAL	00	1
27	310557	WASHER	00	1
27	312961	SCREW	00	1
28	306666	LINT SCREEN Note: SCREEN, LINT	00	1

*Color Code (-)=Not Shown #=Series, Serial Prefix or Run No., N=Not Available

Section: INLET DUCT, GAS VALVE & EXT. (ESG9900)

Model: ESG9900

SECTION: INLET DUCT, GAS VALVE & EXTENSION

MODEL: ESG9900

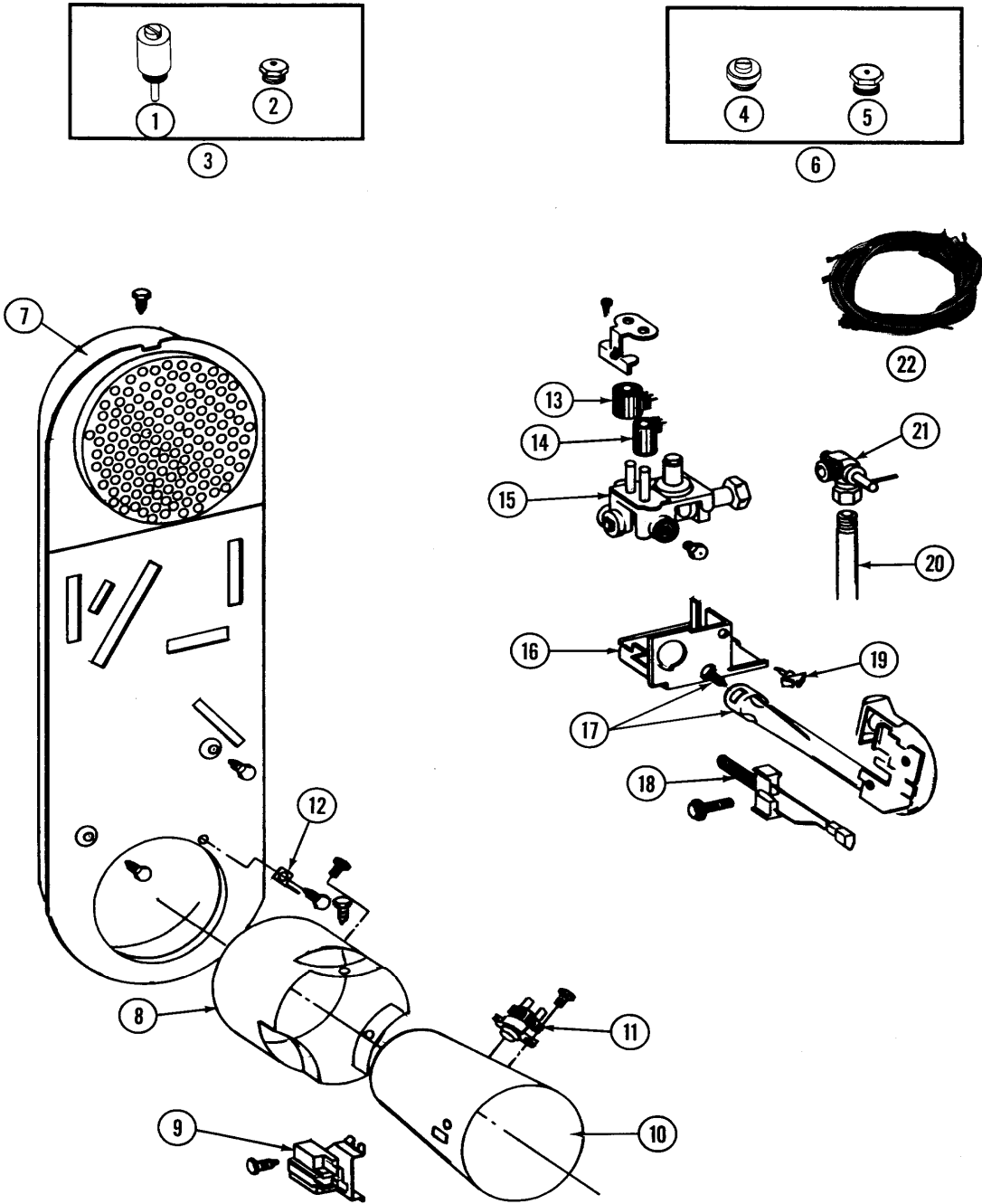

Issue Date: 1/91

20

MA87E11

Section: INLET DUCT, GAS VALVE & EXT. (ESG9900)

No.	Part No.	Description	Series	Qty
1	306184	PLUG, BLOCKING (LPG REGULATOR) Note: PLUG, BLOCKING (LPG REGULATOR)	00	1
2	N 311640	ORIFICE FOR MAIN BURNER Note: ORIFICE, MAIN BURNER	00	1
3	306205	CONVERSION KIT-NAT. TO LPG Note: CONVERSION KIT (NAT. TO LPG)	00	1
4	314602	LEAK LIMITER (LPG) Note: LIMITER, LEAK (LPG)	00	1
5	314603	MAIN BURNER ORIFICE-NAT Note: MAIN BURNER ORIFICE (NAT)	00	1
6	306206	CONVERSION KIT-LPG TO NAT. Note: CONVERSION KIT (LPG TO NAT.)	00	1
-	211294	SCREW	00	3
7	303369	INLET DUCT ASSEMBLY - DG Note: INLET DUCT ASSEMBLY	00	1
-	211294	SCREW	00	3
8	314509	COMBUSTION CONE EXTENSION Note: EXTENSION, COMBUSTION CONE	00	1
-	211294	SCREW	00	1
9	303377	SENSOR, RADIANT	00	1
-	211294	SCREW	00	3
10	303368	CONE, COMBUSTION	00	1
-	211294	SCREW	00	1
11	303395	THERMOSTAT, HI-LIMIT (GAS)	00	1
12	312890	RETAINER, HEATER CHAMBER	00	1
-	211294	SCREW	00	2
13	306106	COIL, HOLDING & BOOSTER	00	1
14	306105	COIL, SECONDARY	00	1
15	306084	VALVE, GAS	00	1
-	314082	SCREW	00	1
16	314508	BRACKET FOR GAS VALVE Note: BRACKET, GAS VALVE	00	1
-	251119	SCREW	00	1
17	306162	BURNER ASSEMBLY WITH SCREW Note: BURNER ASSEMBLY (W/SCREW)	00	1
18	304970	IGNITER ASSY, GAS VALVE	00	1
-	304971	SCREW	00	1
19	N 313262	RETAINER, WIRE HARNESS	00	1
20	N 310454	MANIFOLD, 2 INCH Note: MANIFOLD (2")	00	1
21	306086	ANGLE SHUT OFF FOR GAS VALV Note: ANGLE SHUT OFF, GAS VALVE	00	1
22	306090	WIRE HARNESS FOR GAS VALVE Note: WIRE HARNESS, GAS VALVE	00	1

*Color Code (-)=Not Shown #=Series, Serial Prefix or Run No., N=Not Available

Section: TOP COVER (ESE9900 & ESG9900)

Model: ESG9900

SECTION: TOP COVER, LID & LID LOCK ASSEMBLY
MODEL: ESE9900 - ESG9900

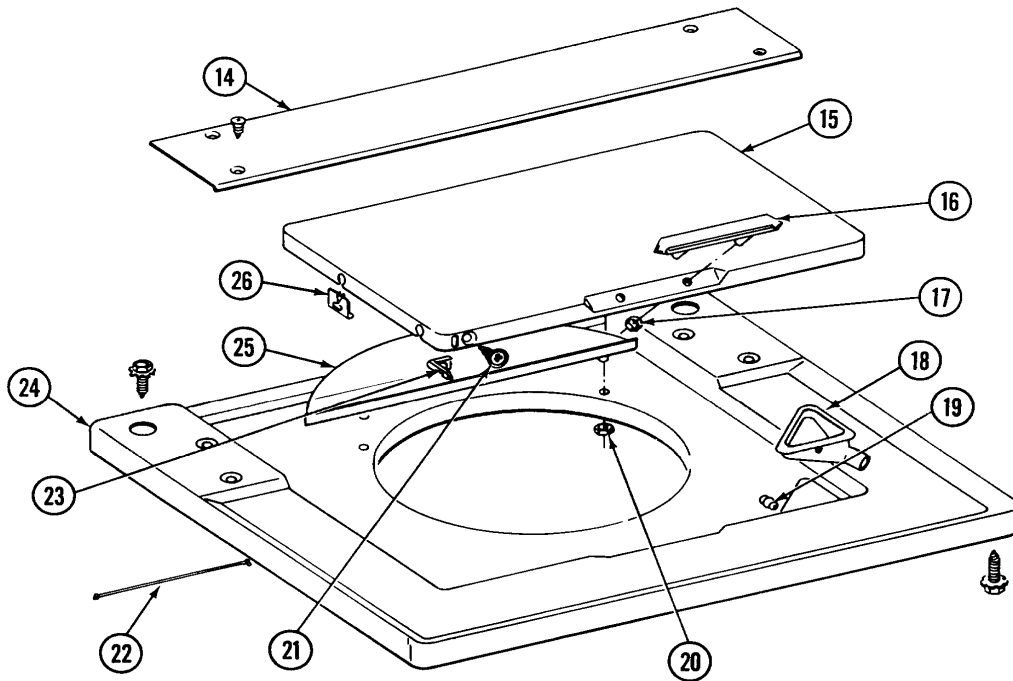
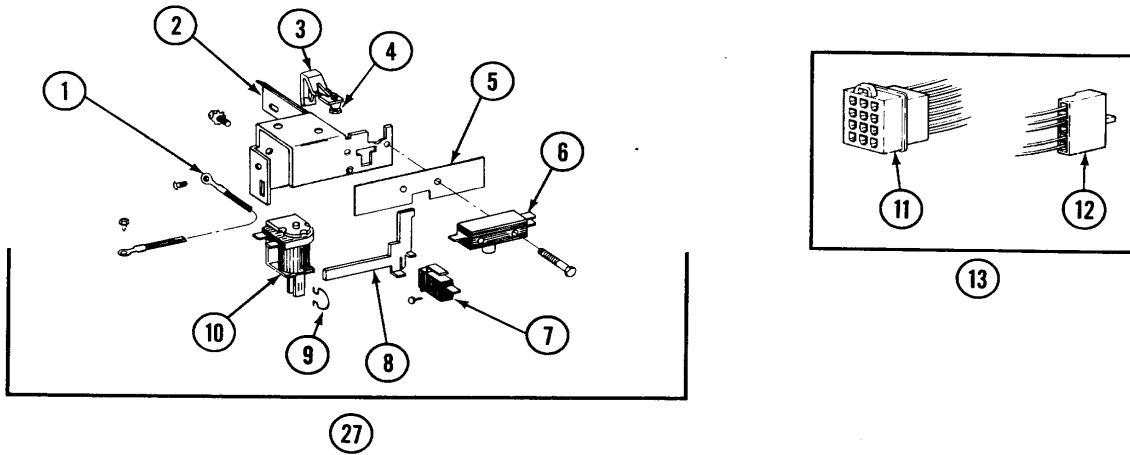

Issue Date: 1/91

22

MA87E13

Section: TOP COVER (ESE9900 & ESG9900)

No.	Part No.	Description	Series	Qty
1	204807	GRND.WIRE,SUPP.PLTE TO TOP CVR Note: GROUND WIRE, SUPPORT PLATE	00	1
-	211252	SCREW	00	1
2	N 215379	BRACKET, LID SWITCH/LATCH Note: LID SWITCH & LATCH BRACKET	00	1
3	215378	LID SWITCH LEVER Note: LEVER, LID SWITCH	00	1
4	213648	SCREW, HEX HD #8 X 5/8 Note: SCREW (HEX HD #8 X 5/8")	00	1
5	215270	MOISTURE BARRIER Note: BARRIER, MOISTURE	00	1
6	205415	SWITCH, LID (W/O TUB LIGHT)	00	1
-	N 215381	SCREW	00	2
7	206417	LOCK SWITCH Note: SWITCH, LOCK	00	1
-	912012	SCREW	00	1
8	215268	LID LATCH LEVER Note: LEVER, LID LATCH	00	1
9	N 215292	SPRING FOR SOLENOID Note: SPRING, SOLENOID	00	1
10	212951	SCREW, #6-32 X 1/4 INCH Note: SCREW (#6-32 X 1/4")	00	2
10	206416	SOLENOID	00	1
-	N 213076	PIN FOR PLUG Note: PIN, PLUG	00	12
11	215539	PIN HOUSING Note: HOUSING, PIN	00	1
12	206420	EDGE CONNECTOR ASSEMBLY	00	1
13	206849	D.C. WIRE HARNESS Note: WIRE HARNESS (DC)	00	1
-	314664	SCREW	00	2
14	N 215245	BRIDGE FOR TOP COVER NA Note: BRIDGE, TOP COVER	00	1
15	215251	LID-WHITE Note: LID (WHT)	00	1
16	206667	HANDLE WITH NUTS Note: HANDLE (W/NUTS)	00	1
-	215550	STUD FOR LID HANDLE Note: STUD, LID HANDLE	00	2
17	215551	PALNUT	00	2
-	215374	GASKET FOR BLEACH CUP Note: GASKET, BLEACH CUP	00	1
18	215579	CUP, BLEACH (WHITE) Note: CUP, BLEACH (WHT)	00	1
19	215247	BUMPER FOR LID Note: BUMPER, LID	00	2
20	215249	PALNUT-RETAINER Note: PALNUT, RETAINER	00	3
-	212087	SCREW, #6 X 1/2 INCH Note: SCREW (#6 X 1/2")	00	1
21	211500	WASHER,BRACKE TO TOP COVER Note: WASHER, BRACKET	00	1
22	N 215274	TOP COVER RESTRAINT Note: RESTRAINT, TOP COVER	00	1
23	N 215254	LATCH HOOK Note: HOOK, LATCH	00	1
-	214354	SCREW	00	4
24	N 207579	TOP COVER (WHITE) Note: TOP COVER (WHT)	00	1
25	215246	SPLASH SHIELD Note: SHIELD, SPLASH	00	1
26	215253	KEY HOLE GLIDE Note: GLIDE, KEY HOLE	00	4
27	207578	LID LATCH ASSEMBLY	00	1

*Color Code (-)=Not Shown #=Series, Serial Prefix or Run No., N=Not Available

Section: CABINET (ESE9900 & ESG9900)

Model: ESG9900

SECTION: CABINET, TOP COVER & WATER VALVE - REAR VIEW
MODEL: ESE9900 - ESG9900

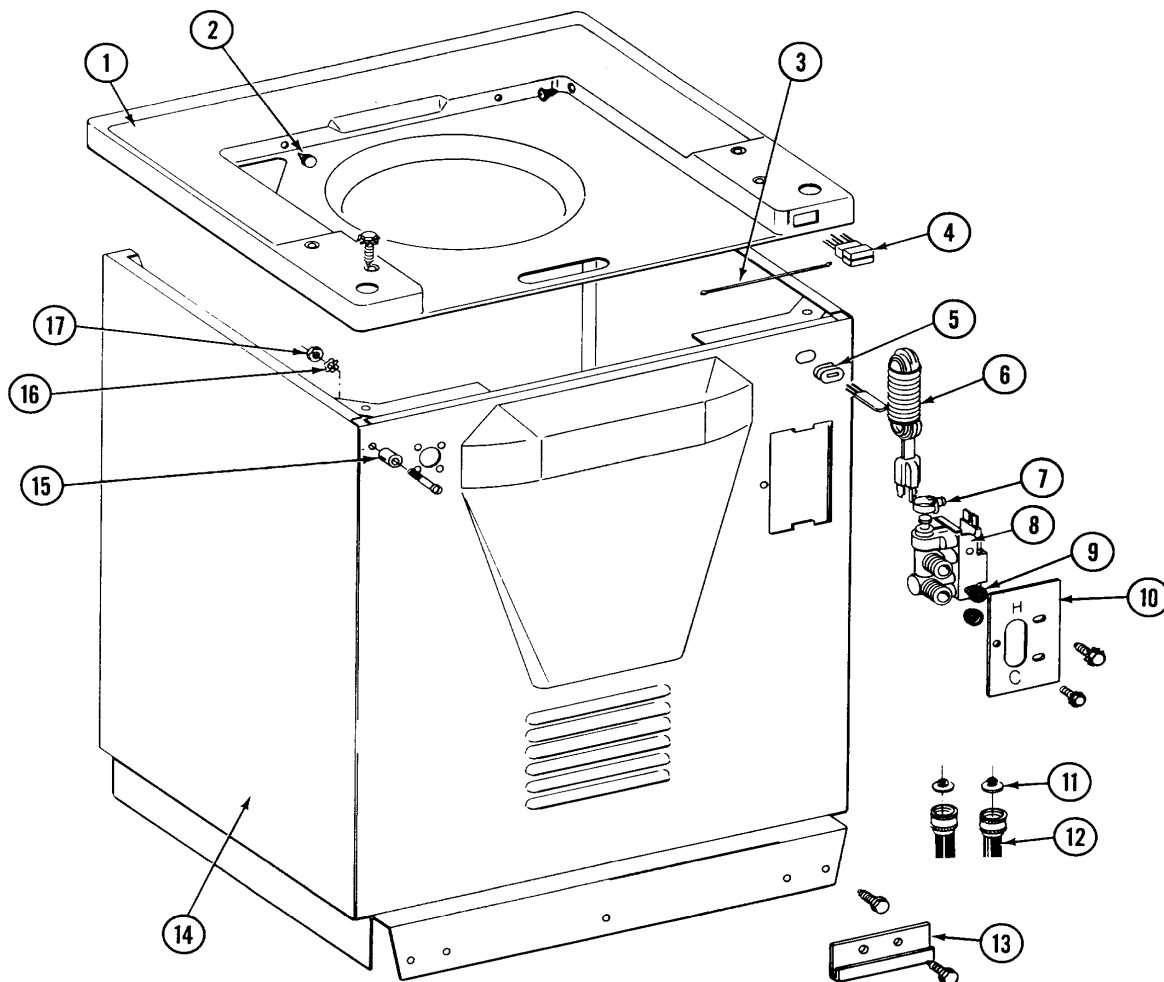

Issue Date: 1/91

26

MA87F3

Section: CABINET (ESE9900 & ESG9900)

No.	Part No.	Description	Series	Qty
1	N 207579	TOP COVER (WHITE) Note: COVER, TOP (WHT)	00	1
-	214354	SCREW	00	4
2	215247	BUMPER FOR LID Note: BUMPER, LID	00	2
3	N 215274	TOP COVER RESTRAINT Note: RESTRAINT, TOP COVER	00	1
4	206420	EDGE CONNECTOR ASSEMBLY	00	1
-	215539	PIN HOUSING Note: HOUSING, PIN	00	1
-	N 213076	PIN FOR PLUG Note: PIN, PLUG	00	12
4	206849	D.C. WIRE HARNESS Note: WIRE HARNESS (DC)	00	1
5	211881	GROMMET, CORD	00	1
-	N 315459	CLIP, POWER CORD	00	1
6	N 206424	POWER CORD Note: CORD, POWER	00	1
-	313559	SCREW	00	1
7	201575	HOSE CLAMP Note: CLAMP, HOSE	00	1
-	N 313561	SCREW---NA	00	2
8	206413	WATER VALVE-DC Note: VALVE, WATER	00	1
9	214337	SCREEN, VALVE	00	2
-	212276	SCREW	00	1
10	215264	BRACKET FOR WATER VALVE Note: BRACKET, WATER VALVE	00	1
11	200961	SCREEN WASHER, INLET HOSE	00	2
12	200672	INLET HOSE ASSY. Note: INLET HOSE ASSEMBLY	00	2
13	N 215278	GLIDE FOR WASHER Note: GLIDE, WASHER	00	2
14	N 207207	CABINET WHT Note: CABINET (WHT)	00	1
-	215277	SCREW	00	1
15	215276	BUSHING	00	1
16	310557	WASHER	00	1
17	052659	HEX. NUT, #8-32 Note: NUT (HEX #8-32")	00	1

*Color Code (-)=Not Shown #=Series, Serial Prefix or Run No., N=Not Available

Section: CABINET & FRT PNL (ESE9900 & ESG9900)

Model: ESG9900

SECTION: CABINET & FRONT PANEL
MODEL: ESE9900 - ESG9900

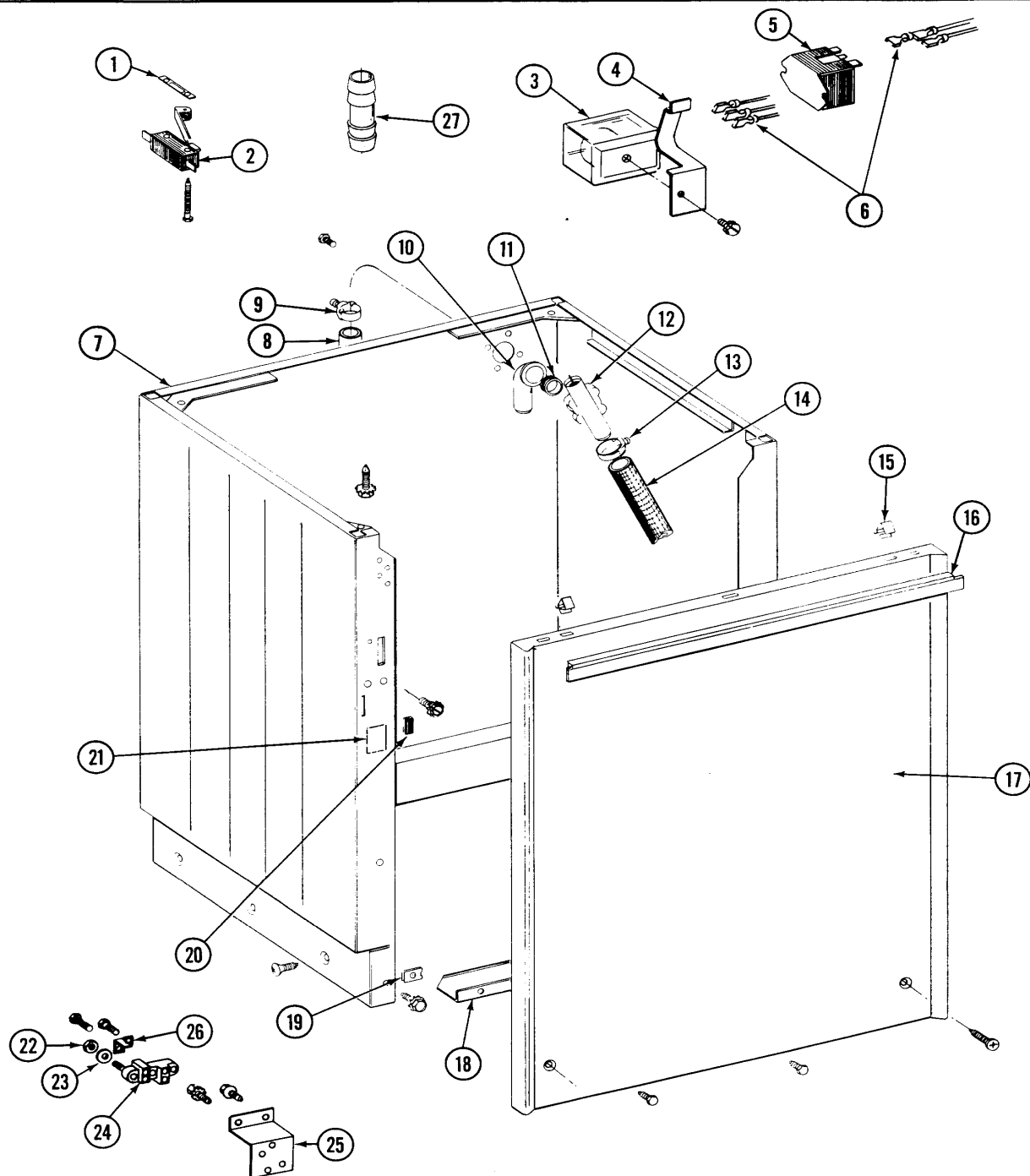

Issue Date: 1/91

24

MA87F1

Section: CABINET & FRT PNL (ESE9900 & ESG9900)

No.	Part No.	Description	Series	Qty
1	210866	TWIN SPEED NUT Note: NUT, TWIN SPEED	00	1
2	202476	UNBALANCE SWITCH Note: SWITCH, UNBALANCE	00	1
-	213501	SCREW, #6-20 X 1-1/8 INCH Note: SCREW (#6-20 X 1-1/8")	00	2
3	206421	RELAY-MOTOR REVERSING Note: RELAY, MOTOR REVERSING	00	1
-	212949	SCREW	00	1
4	215273	SPRING CLIP Note: CLIP, SPRING	00	1
5	901961	RELAY (4 CONTACT)	00	1
6	206423	LOWER WIRE HARNESS-AC Note: WIRE HARNESS (LOWER)	00	1
7	N 207207	CABINET WHT Note: CABINET (WHT)	00	1
-	213122	SCREW,CBNT.TO FRNT OF BASE--NA Note: SCREW, CABINET	00	2
-	213007	SCREW, CABINET	00	6
-	N 059149	(7/8" I.D. CARTON OF 50 FT.)	00	1
8	216017	HOSE, DRAIN (7/8" I.D.)	01	1
8	215279	HOSE, DRAIN	00	1
9	200461	HOSE CLAMP - 1-5/8 INCH Note: CLAMP, HOSE (1-5/8")	00	1
10	216016	ELBOW, SIPHON BREAK	00	1
10	214764	SIPHON BREAK ELBOW Note: ELBOW, SIPHON BREAK	00	1
11	214765	GASKET, SIPHON BREAK	00	1
12	206638	SIPHON BREAK(W/CLAMP) Note: SIPHON BREAK (W/CLAMP)	00	1
-	014874	SCREW	00	4
13	202574	CLAMP, HOSE	00	1
14	215365	HOSE	00	1
15	215711	FASTENER, SPRING	00	2
16	N 215266	TRIM, FRONT PANEL	00	1
17	207205	PANEL, FRONT (WHT)	00	1
-	213123	SCREW, #10 X 7/8 INCH----SUB Note: SCREW (#10 X 7/8")	00	2
18	213846	GUARD, BELT	00	1
-	211294	SCREW	00	3
19	213280	FRONT PANEL BRACKET/FASTENER Note: NUT, SPEED	00	2
20	214376	SPACER, FRONT PANEL	00	2
21	314609	CAUTION LABEL Note: LABEL, CAUTION	00	1
22	311484	NUT, TERMINAL BLOCK	00	2
23	311270	WASHER, TERMINAL BLOCK	00	3
24	400008	BLOCK, TERMINAL	00	1
25	312904	BRACKET, TERMINAL BLOCK	00	1
26	312184	STRAP, GROUND	00	1
27	216015	HOSE COUPLING Note: COUPLING, HOSE	00	1

*Color Code (-)=Not Shown #=Series, Serial Prefix or Run No., N=Not Available

Section: TUB COVER (ESE9900 & ESG9900)

Model: ESG9900

SECTION: TUB COVER, WATER VALVE & WATER INJECTOR ASSEMBLY

MODEL: ESE9900 - ESG9900

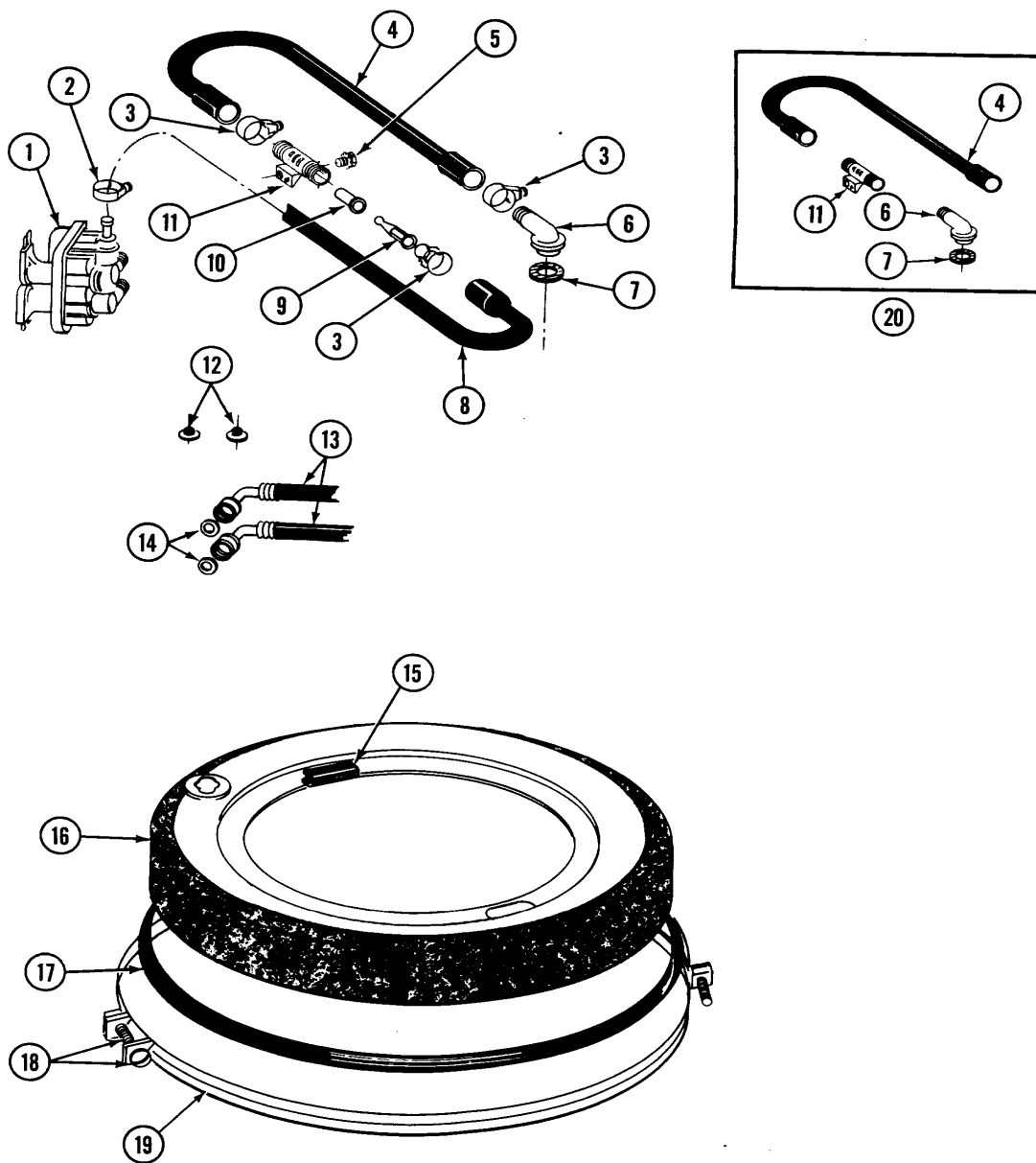

Issue Date: 1/91

Section: TUB COVER (ESE9900 & ESG9900)

No.	Part No.	Description	Series	Qty
1	205613	WATER VALVE Note: VALVE, WATER	00	1
2	201575	HOSE CLAMP Note: CLAMP, HOSE	00	1
3	202515	HOSE CLAMP - 1-1/16 INCH Note: CLAMP, HOSE (1-1/16")	00	3
4	215234	INJECTOR FILL HOSE Note: FILL HOSE, INJECTOR	00	1
5	310632	SCREW	00	1
6	215235	INJECTOR TUBE Note: TUBE, INJECTOR	00	1
7	215233	SEAL FOR INJECTOR TUBE Note: SEAL, INJECTOR TUBE	00	1
8	213013	HOSE, INJECTOR Note: HOSE, INJECTOR	00	1
9	213015	INJECTOR NOZZLE Note: NOZZLE, INJECTOR	00	1
10	213016	VALVE FOR INJECTOR SUB Note: VALVE, INJECTOR	00	1
11	213057	SLEEVE FOR INJECTOR Note: SLEEVE, INJECTOR	00	1
12	200961	SCREEN WASHER, INLET HOSE Note: SCREEN WASHER, INLET HOSE	00	2
13	200672	INLET HOSE ASSY. Note: INLET HOSE ASSEMBLY	00	2
14	013783	GASKET, INLET HOSE Note: WASHER, INLET HOSE	00	2
15	013783	GASKET, INLET HOSE Note: WASHER, INLET HOSE	00	2
16	207775	TUB COVER ASSY Note: TUB COVER ASSEMBLY	00	1
17	211232	SEAL	00	1
18	205529	NUT & BOLT KIT FOR TUB CLAM Note: TUB CLAMP NUT & BOLT KIT	00	2
19	200846	CLAMP - TUB COVER Note: CLAMP, TUB COVER	00	2
20	206531	INJECTOR HOSE KIT	00	1

*Color Code (-)=Not Shown #=Series, Serial Prefix or Run No., N=Not Available

Section: TUB (ESE9900 & ESG9900)

Model: ESG9900

SECTION: INNER TUB, OUTER TUB, AGITATOR & WATER LEVEL SWITCH
MODEL: ESE9900 - ESG9900

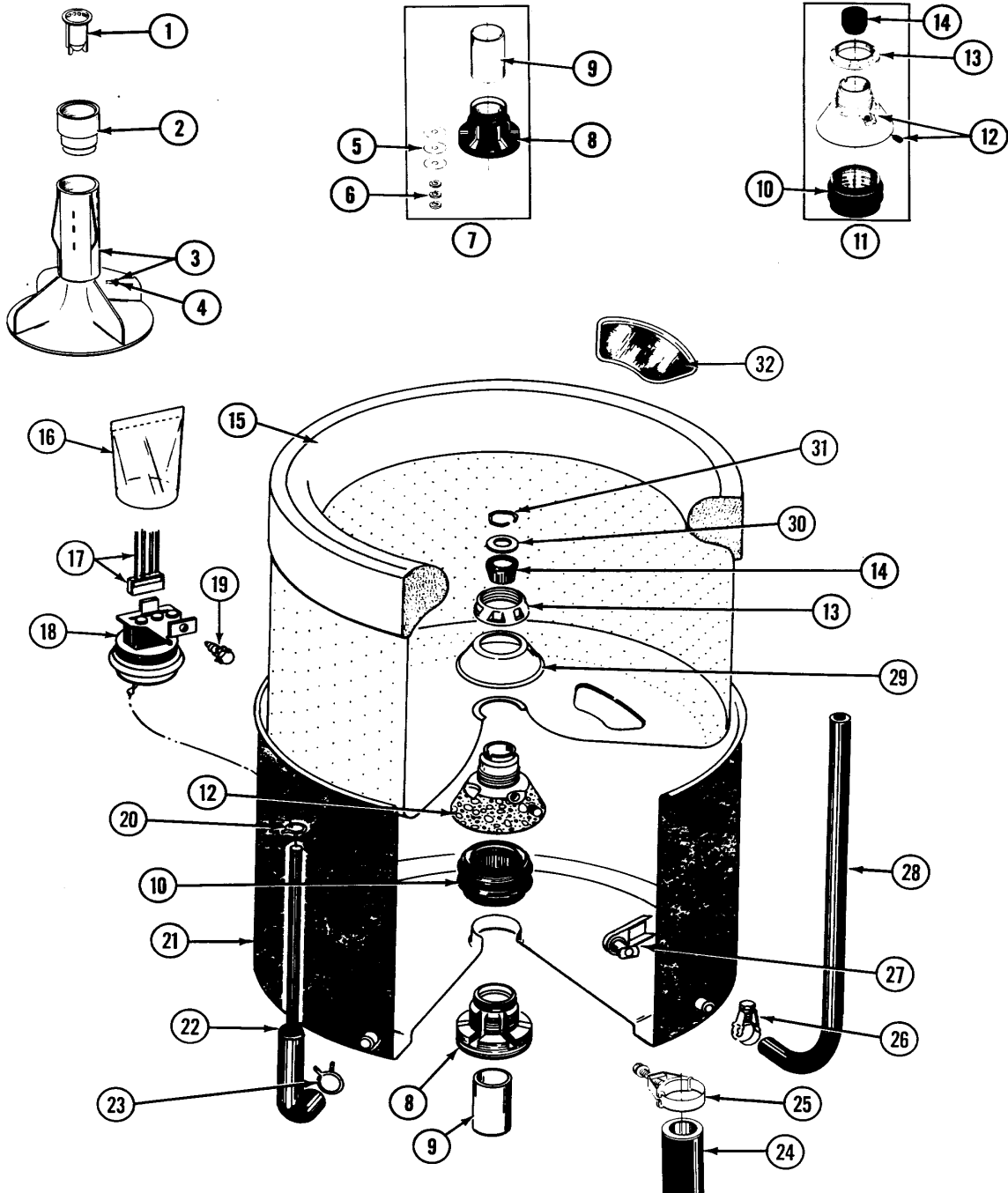

Issue Date: 1/91

Section: TUB (ESE9900 & ESG9900)

No.	Part No.	Description	Series	Qty
1	215733	DISPENSING CUP Note: CUP, DISPENSING	00	1
2	215721	DISPENSING CAP Note: CAP, DISPENSING	00	1
3	207538	AGITATOR W/LOCK SCREW Note: AGITATOR (W/LOCK SCREW)	00	1
4	206478	SCREW & WASHER FOR AGITATOR Note: SCREW & WASHER, AGITATOR	00	1
5	211100	WASHER, CUSHION	00	3
6	054867	WASHER, LOCK	00	1
7	204013	TUB BEARING REPAIR KIT	00	1
8	200824	BEARING, TUB	00	1
9	211130	LINER, TUB BEARING	00	1
10	201537	SEAL AND SPRING Note: SEAL & SPRING	00	1
11	204012	MOUNTING STEM REPAIR KIT	00	1
12	202521	MOUNTING STEM Note: STEM, MOUNTING	00	1
13	211047	NUT, CLAMPING (INNER TUB)	00	1
14	0A4298	SEAL, AGITATOR DRIVE SHAFT	00	1
15	N 207830	INNER TUB W/PLUG Note: TUB, INNER (W/PLUG)	00	1
16	215081	POLY BAG Note: BAG, POLY	00	1
17	206849	D.C. WIRE HARNESS Note: WIRE HARNESS (DC)	00	1
18	206418	WATER LEVEL SWITCH-DIGITAL Note: SWITCH, WATER LEVEL (DIGITAL)	00	1
19	313559	SCREW	00	1
20	410296	CLAMP,WATER LEVEL SWTCH TUBE Note: CLAMP, WATER LEVEL SWITCH TUBE	00	1
21	206405	OUTER TUB Note: TUB, OUTER	00	1
22	215258	AIR DOME AND TUBE Note: AIR DOME & TUBE	00	1
23	211641	CLAMP, 1-1/16" Note: CLAMP (1-1/16")	00	1
24	213045	DRAIN HOSE-TUB TO PUMP Note: HOSE, OUTER TUB	00	1
25	200900	CLAMP, SPRAY ARM HOSE	00	1
26	205161	CLAMP - 15/16" Note: CLAMP, BLEACH HOSE	00	1
27	214434	SPOUT, DEFLECTOR	00	1
28	214495	TUBE, INLET TO TUB Note: TUBE, INLET	00	1
29	211210	WASHER,CLAMPING NUT(STAINLESS) Note: WASHER, CLAMPING NUT	00	1
30	015666	WASHER,RETAINING(CENTER SEAL)- Note: WASHER, RETAINING	00	1
31	015667	RETAINING RING	00	1
32	207219	FILTER, SELF-CLEANING	00	2

*Color Code (-)=Not Shown #=Series, Serial Prefix or Run No., N=Not Available

Section: TRANSMISSION (ESE9900 & ESG9900)

Model: ESG9900

SECTION: TRANSMISSION - ORBITAL

MODEL: ESE9900 - ESG9900

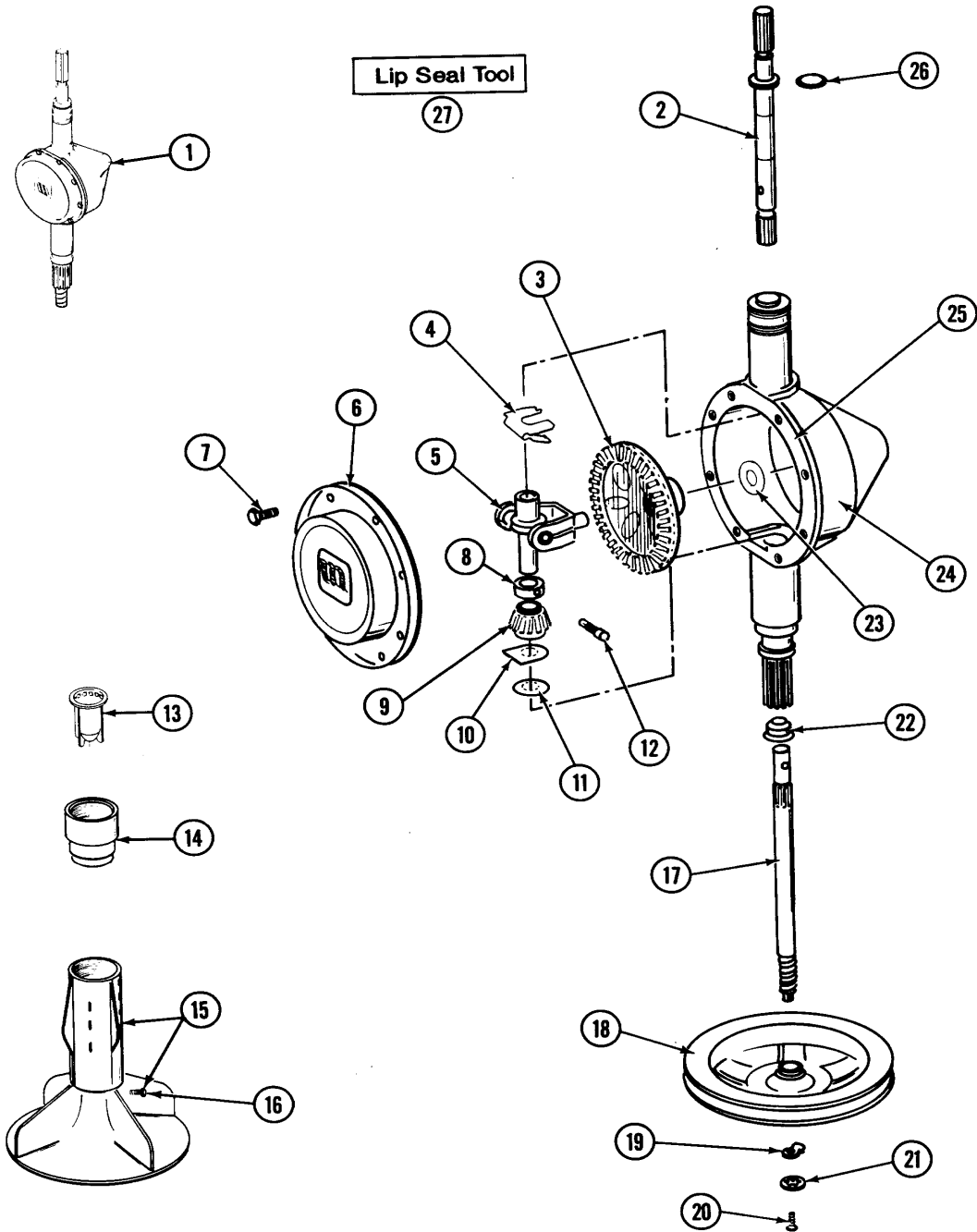

Issue Date: 1/91

32

MA87F9

Section: TRANSMISSION (ESE9900 & ESG9900)

No.	Part No.	Description	Series	Qty
1	206707	TRANSMISSION, ORBITAL	00	1
2	207153	SHAFT, AGITATOR (W/SPRING)	00	1
3	206713	GEAR, BEVEL	00	1
4	215581	SPRING, AGITATOR SHAFT	00	1
5	206685	BLOCK, TORQUE AND YOKE ASSEMBL	00	1
6	206628	COVER, TRANSMISSION	00	1
7	215417	SCREW, TRANSMISSION COVER	00	8
8	215415	COLLAR, LOWER Note: COLLAR (LOWER)	00	1
9	215401	PINION	00	1
10	215395	PLATE, CLUTCH	00	1
11	211483	WASHER, SPLINED	00	1
12	206629	PIN, COLLAR	00	1
13	215733	DISPENSING CUP Note: CUP, DISPENSING	00	1
14	215721	DISPENSING CAP Note: CAP, DISPENSING	00	1
15	207538	AGITATOR W/LOCK SCREW Note: AGITATOR (W/LOCK SCREW)	00	1
16	206478	SCREW & WASHER FOR AGITATOR Note: SCREW & WASHER, AGITATOR	00	1
17	215410	CENTER SHAFT - LARGER Note: SHAFT, CENTER (LARGER)	00	1
18	211059	PULLEY, DRIVE	00	1
19	211089	LUG, STOP	00	1
20	211375	SCREW,STOP LUG(CENTER SHAFT) Note: SCREW, STOP LUG	00	1
21	211090	WASHER, LOCK	00	1
22	206602	SEAL, LIP (CENTER SHAFT)	00	1
23	215394	WASHER, BEVEL GEAR	00	1
24	206624	HOUSING, TRANSMISSION	00	1
25	058700	SILASTIC,ADH.SEALANT Note: SILASTIC, ADHESIVE SEALANT	00	1
26	210690	SEAL, RUBBER	00	1
27	N 038228	LIP SEAL TOOL Note: TOOL, LIP SEAL	00	1

*Color Code (-)=Not Shown #=Series, Serial Prefix or Run No., N=Not Available

Section: BASE (ESE9900 & ESG9900)

Model: ESG9900

SECTION: BASE, TUB BRACES, DAMPER ASSEMBLY & TRANSMISSION
MODEL: ESE9900 - ESG9900

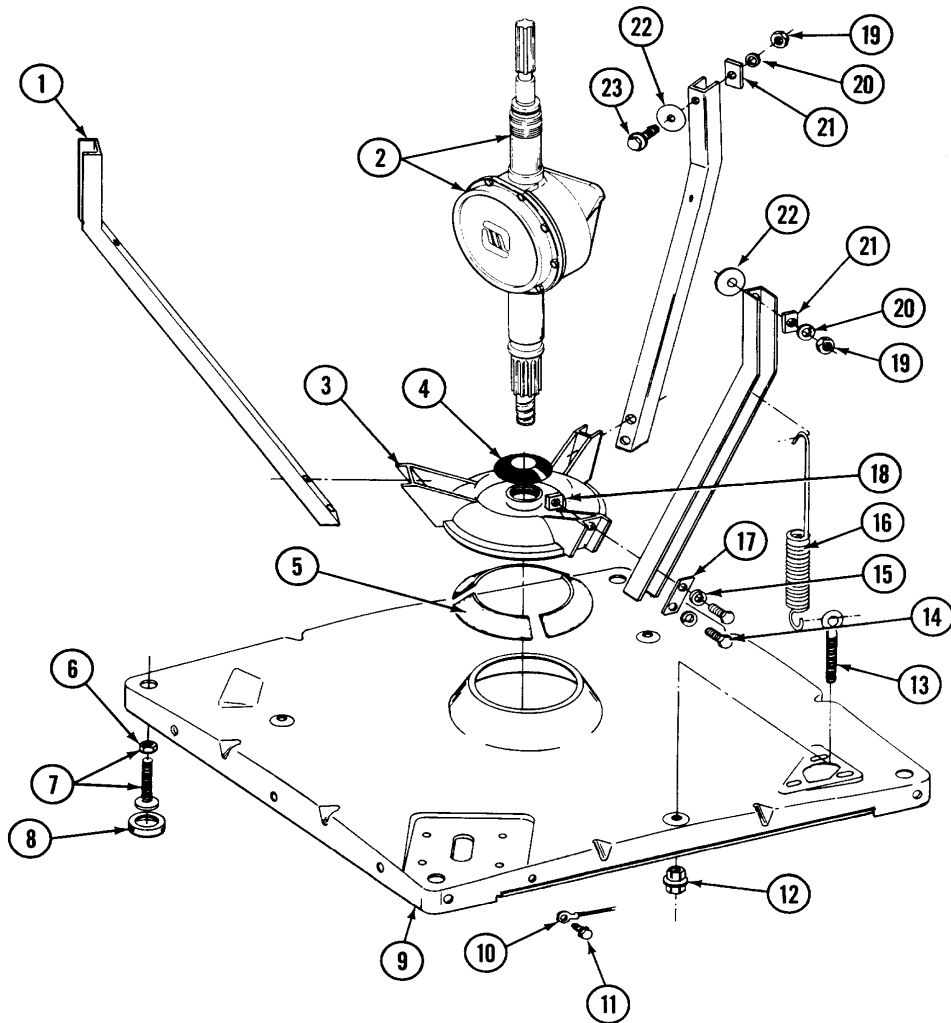

Issue Date: 1/91

Section: BASE (ESE9900 & ESG9900)

No.	Part No.	Description	Series	Qty
1	213100	BRACE, TUB	00	1
2	206707	TRANSMISSION, ORBITAL	00	1
3	203725	DAMPER W/BOLT & CLIP Note: DAMPER (W/BOLT & CLIP)	00	1
4	211028	DEFLECTOR,WATER (DRIVE TUBE) Note: DEFLECTOR, WATER	00	1
5	203956	DAMPER PAD KIT (W/POLY LUBE)	00	1
6	210385	NUT, LOCK	00	4
7	302699	LEG, ADJUSTABLE (W/NUT)	00	4
8	210684	FOOT, RUBBER	00	4
9	203274	BASE WITH DAMPER PADS Note: BASE, DAMPER PADS	00	1
10	204807	GRND.WIRE,SUPP.PLTE TO TOP CVR Note: GROUND WIRE, SUPPORT PLATE	00	1
11	210186	SCREW, GROUND WIRE TO BASE--NA Note: SCREW, GROUND WIRE	00	1
12	211949	NUT, EYEBOLT	00	3
13	213120	EYE BOLT FOR CENTER SPRING Note: EYE BOLT, CENTER SPRING	00	3
14	015627	SCREW, HEX HD CAP 5/16 X 5/8	00	6
15	911852	WASHER, LOCK (BRACE)	00	6
16	213054	CENTERING SPRING - 3 USED Note: SPRING, CENTERING	00	3
17	213073	WASHER, DOUBLE Note: WASHER, DOUBLE	00	3
18	052785	NUT,BRACE TO DAMPER Note: NUT, BRACE TO DAMPER	00	6
19	052734	NUT Note: NUT, BRACE TO TUB	00	3
20	054867	WASHER, LOCK	00	3
21	212979	WASHER, TUB BRACE	00	3
22	211100	WASHER, CUSHION	00	3
23	200744	BOLT & GASKET ASSY.(SHORT) Note: BOLT & GASKET ASSY. (SHORT)	00	1
23	205254	BOLT & GASKET ASSEMBLY (LONG) Note: (LONG)	00	2

*Color Code (-)=Not Shown #=Series, Serial Prefix or Run No., N=Not Available

Section: MOTOR & PUMP ASSY (ESE9900 & ESG9900)

Model: ESG9900

SECTION: MOTOR & PUMP ASSEMBLY

MODEL: ESE9900 - ESG9900

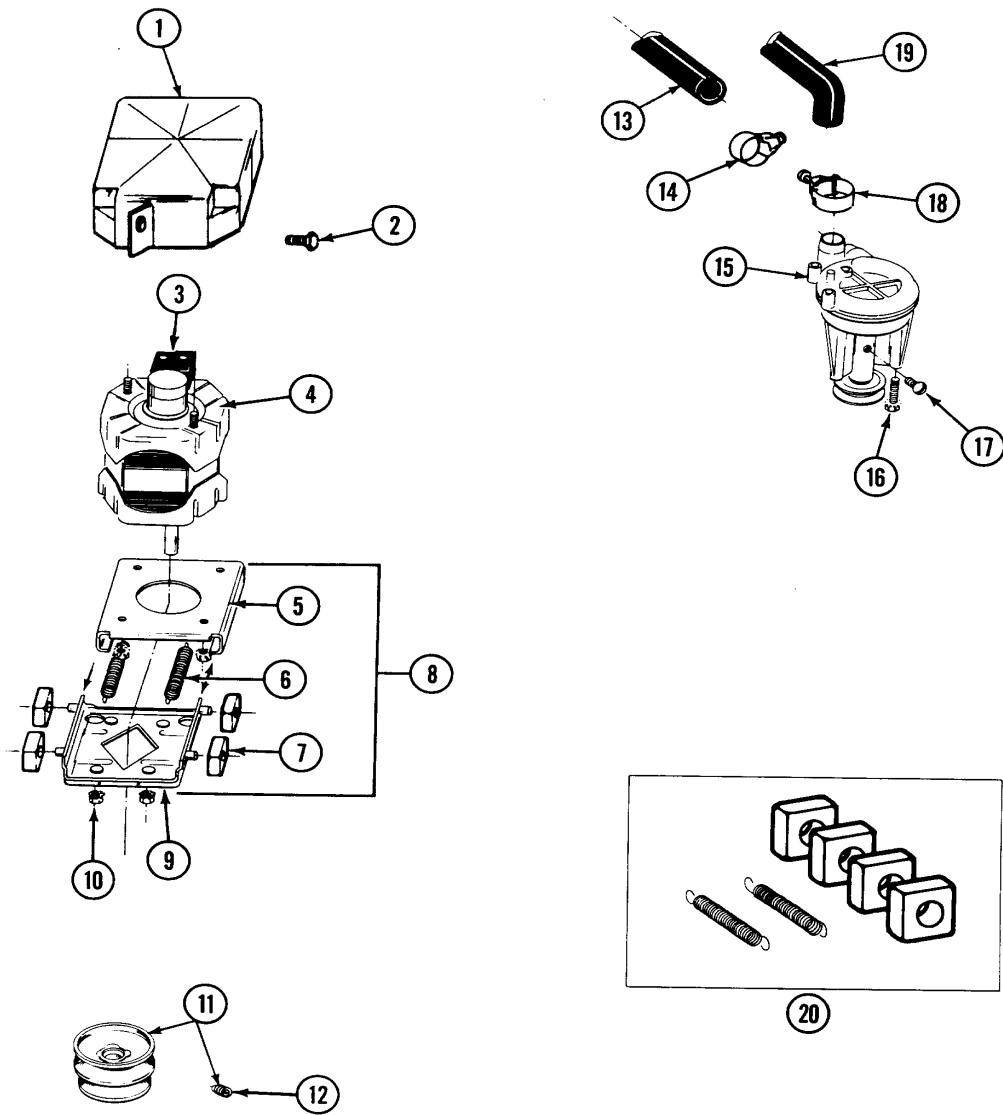

Issue Date: 1/91

Section: MOTOR & PUMP ASSY (ESE9900 & ESG9900)

No.	Part No.	Description	Series	Qty
1	215098	SHIELD, MOTOR	00	1
2	213121	SCREW	00	1
3	N 205133	MOTOR EXTERNAL START SWITCH Note: SWITCH, MOTOR EXTERNAL START (PROD.ID#2-1664-8, 2-5463)	00	1
3	206505	SWITCH, MOTOR START Note: SWITCH, MOTOR EXTERNAL START (PROD.ID#2-1664-11,2-5463-1)	00	1
3	205132	SWITCH, MOTOR START Note: SWITCH, MOTOR EXTERNAL START (PROD.ID#2-1664-4,2-1664-9, 2-1664-12,2-5463-2)	00	1
4	201805	MOTOR (ONE SPEED)	00	1
5	214956	MOUNT, MOTOR/UPPER Note: PLATE, MOTOR MOUNT (UPPER)	00	1
6	202718	TENSION SPRINGS Note: SPRINGS, TENSION	00	1
7	204998	GLIDE KIT (4 W/POLY LUBE)	00	1
8	205999	MOTOR MOUNT ASSM COMPLETE Note: MOTOR MOUNT ASSY. (COMPLETE)	00	1
9	205908	LOWER MOTOR MOUNT Note: MOUNT, MOTOR (LOWER)	00	1
10	311426	NUT, WASHERED LOCK Note: KEPS NUT, MOTOR BASE	00	3
11	200816	PULLEY, MOTOR (W/SET SCREW)	00	1
12	053241	SET SCREW, PULLEY	00	1
13	215365	HOSE	00	1
14	200461	HOSE CLAMP - 1-5/8 INCH Note: CLAMP, HOSE (1-5/8")	00	1
15	202203	PUMP AS PAK	00	1
16	211880	SCREW, HEX HD #10 X 1/2 INC Note: SCREW (HEX HD #10 X 1/2")	00	1
17	015408	SCREW, BEARING INSERT	00	1
18	202574	CLAMP, HOSE	00	1
19	212989	HOSE, OUTER TUB TO PUMP Note: HOSE, OUTER TUB	00	1
20	205000	GLIDE & SPRING KIT	00	1

*Color Code (-)=Not Shown #=Series, Serial Prefix or Run No., N=Not Available

Section: CLUTCH, BRAKE & BELTS (ESE9900, ESG9900)

Model: ESG9900

SECTION: CLUTCH, BRAKE & BELTS

MODEL: ESE9900 - ESG9900

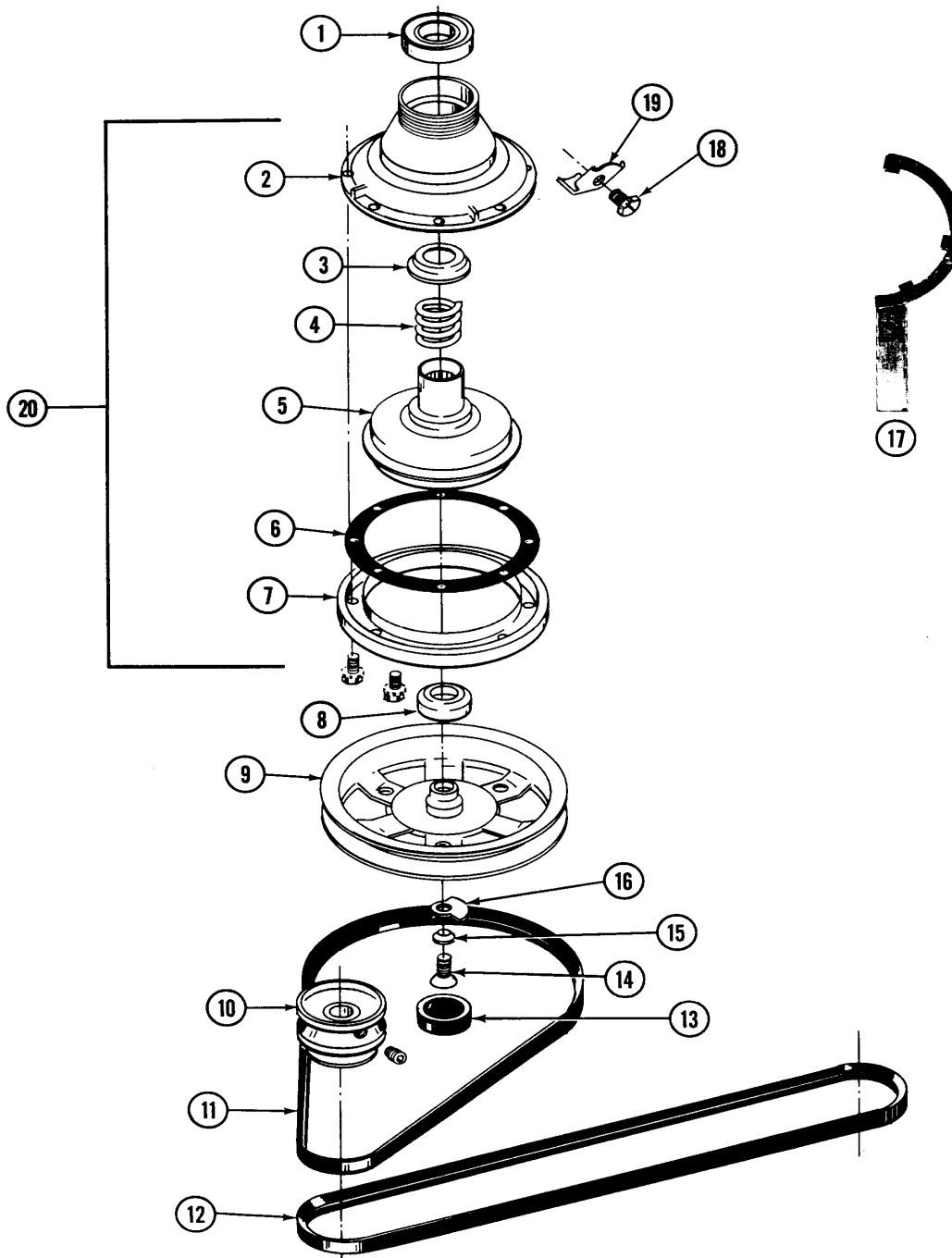

Issue Date: 1/91

Section: CLUTCH, BRAKE & BELTS (ESE9900, ESG99)

No.	Part No.	Description	Series	Qty
1	200720	BALL BEARING, RADIAL	00	1
2	211045	HOUSING, BRAKE	00	1
3	211039	RETAINER, BRAKE SPRING	00	1
4	211041	SPRING, BRAKE	00	1
5	201126	ROTOR, BRAKE (W/FACING)	00	1
6	211042	GASKET, BRAKE DRUM	00	1
-	211000	SCREW,HEX HEAD (BRAKE DRUM) Note: SCREW, BRAKE DRUM (HEX HD)	00	8
7	211043	DRUM, BRAKE	00	1
8	200835	BEARING, BRAKE ROTOR	00	1
9	211059	PULLEY, DRIVE	00	1
-	053241	SET SCREW, PULLEY	00	1
10	200816	PULLEY, MOTOR (W/SET SCREW)	00	1
11	211125	V BELT,DRIVE PULLEY Note: V BELT, DRIVE PULLEY	00	1
12	211124	V BELT, PUMP	00	1
13 N	211038	CAP, OIL RETAINER	00	1
14	211375	SCREW,STOP LUG(CENTER SHAFT) Note: SCREW, STOP LUG	00	1
15	211090	WASHER, LOCK	00	1
16	211089	LUG, STOP	00	1
17	038315	TOOL, BRAKE PKG ASSY Note: TOOL, BRAKE PACKAGE ASSY.	00	1
18	213326	SCREW, RETAINING CLIP Note: BOLT, RETAINING CLIP	00	1
19	213325	CLIP, RETAINER	00	1
20	201190	BRAKE ASSEMBLY Note: PACKAGE, BRAKE	00	1

*Color Code (-)=Not Shown #=Series, Serial Prefix or Run No., N=Not Available