

Repair Parts List

MODEL NUMBER

GA104

WASHER

When requesting service or ordering parts, always provide the following information:

- Product Type
- Part Number
- Model Number
- Part Description

MAYTAG®

©2005 Maytag Services

Section: CONTROL PANEL

Model: GA104

Section: CONTROL PANEL

P/N 16000218

Models: A104 A183 A282

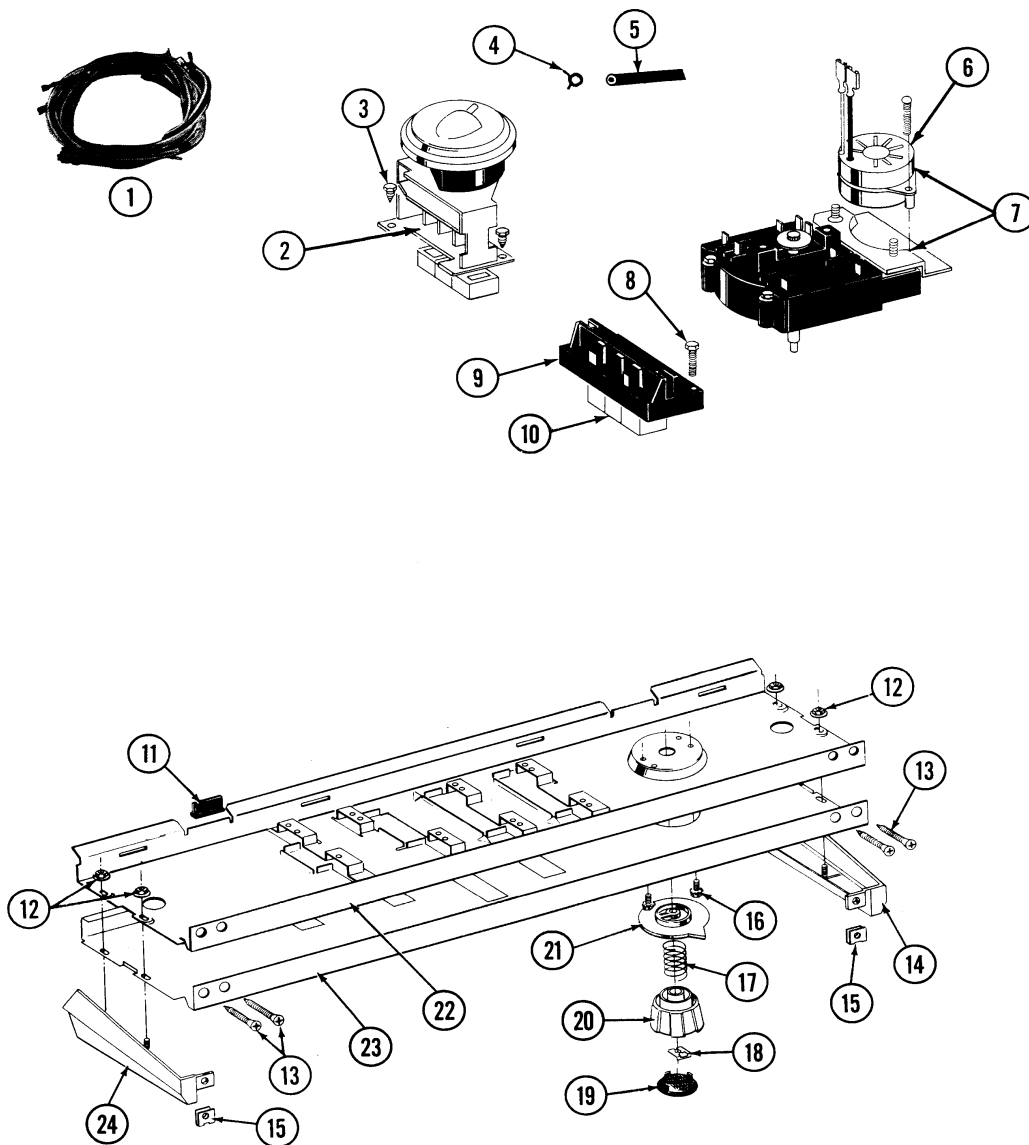

11/91

Section: CONTROL PANEL

No.	Part No.	Description	Series	Qty
1	N 206239	WIRE HARNESS Note: HARNESS, WIRE	00	1
2	206513	WATER LEVEL CONTROL SWITCH Note: SWITCH, WATER LEVEL	00	1
3	211168	SCREW, #8 X 5/16 INCH	00	2
4	410296	CLAMP,WATER LEVEL SWTCH TUBE Note: CLAMP, TUBE	00	1
5	212942	AIR DOME AND TUBE Note: AIR DOME & TUBE	00	1
6	205033	TIMER MOTOR 120-60 Note: MOTOR, TIMER (120-60)	00	1
7	206686	TIMER	00	1
8	213117	SCREW-TEMP. SWITCH TO PANEL Note: SCREW, TEMP SWITCH	00	2
9	206216	WATER TEMPERATURE SWITCH Note: SWITCH, TEMPERATURE	00	1
10	215211	BUTTON FOR SWITCH Note: BUTTON, SWITCH	00	1
11	N 214897	PAD, CONTROL PANEL	00	2
12	214872	PALNUT, END CAP	00	4
13	210932	SCREW, #8 X 9/16 CTSK Note: SCREW, PANEL & END CAP (CHR)	00	4
14	214816	END CAP F/CONTROL PANEL-RH Note: CAP, END (RH)	00	1
15	214894	FASTENER, END CAP	00	2
16	213966	SCREW-TIMER TO CONTROL PANE Note: SCREW, TIMER	00	1
17	211065	SPRING, TIMER KNOB	00	1
18	211605	RETAINER, TIMER KNOB	00	1
19	214806	CAP FOR TIMER KNOB Note: CAP, TIMER KNOB	00	1
20	215162	TIMER KNOB Note: KNOB, TIMER	00	1
21	215161	TIMER DIAL INDICATOR Note: INDICATOR, TIMER DIAL	00	1
22	214818	BACK UP PLATE Note: PLATE, BACK UP	00	1
23	N 206570	CONTROL PANEL Note: PANEL, CONTROL	00	1
24	N 214815	END CAP F/CONTROL PANEL-LH Note: CAP, END (LH)	00	1

*Color Code (-)=Not Shown #=Series, Serial Prefix or Run No., N=Not Available

Section: TOP

Model: GA104

Section: TOP
Models: ALL MODELS

P/N 1600021

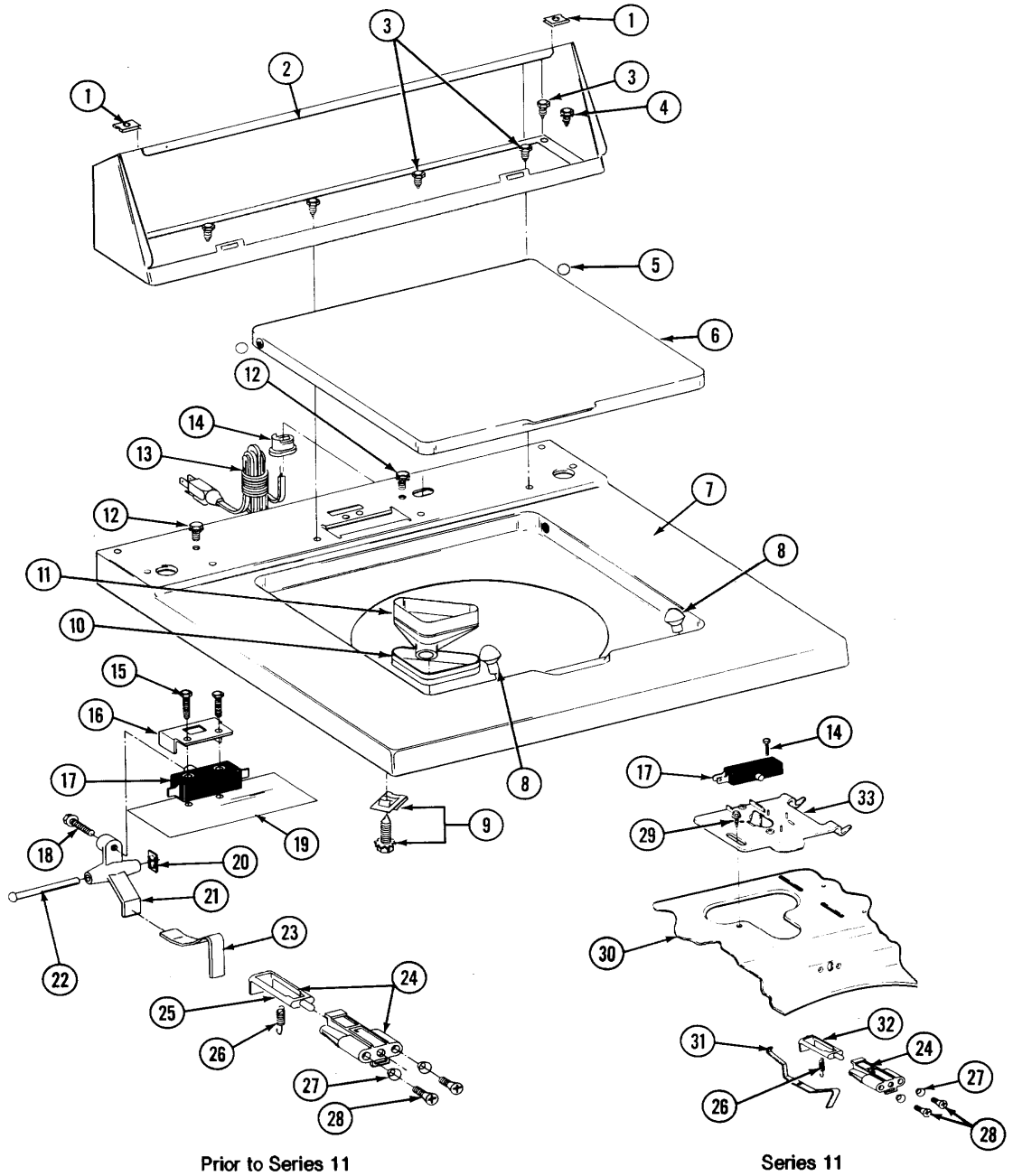

11/91

Section: TOP

No.	Part No.	Description	Series	Qty
1	215075	FASTENER,CNTRL PNL TO CONSOLE Note: FASTENER, CONTROL PANEL	00	2
2	N 205635	CONSOLE (WHT) Note: CONSOLE (WHT)	00	1
2	N 205635L	CONSOLE (ALM) Note: (ALM)	00	1
2	N 205635M	CONSOLE (HVST WHEAT) Note: (H. WHEAT)	00	1
3	211294	SCREW Note: SCREW	00	5
4	N 313551	SCREW, CONSOLE GROUND	00	1
5	211726	HINGE, BALL	00	2
6	N 212073M	LID-HARVEST WHEAT Note: (H. WHEAT)	00	1
6	212073	LID-WHITE Note: LID (WHT)	00	1
6	212073L	LID-ALMOND Note: (ALM)	00	1
7	N 205538M	TOP COVER-HARVEST WHEAT Note: (H. WHEAT)	00	1
7	N 205538L	TOP COVER-ALMOND Note: (ALM)	00	1
7	N 205538	TOP COVER-WHITE Note: TOP COVER, (WHT)	00	1
8	212716	BUMPER, LID	00	2
9	204445	SCREW & FASTENER ASY. Note: SCREW & FASTENER ASSEMBLY	00	2
10	214436	GASKET Note: PART NOT USED	00	1
11	214437	BLEACH INLET Note: PART NOT USED	00	1
12	210186	SCREW, GROUND WIRE TO BASE--NA Note: SCREW, GROUND WIRE	00	2
13	204590	POWER CORD Note: CORD, POWER	00	1
14	211881	GROMMET, CORD	00	1
15	213501	SCREW, #6-20 X 1-1/8 INCH	00	2
16	214898	COVER FOR LID SWITCH Note: COVER, LID SWITCH	00	1
17	205415	SWITCH, LID (W/O TUB LIGHT)	00	1
18	911267	SCREW, PUMP COVER	00	1
19	214987	MOISTURE BARRIER FOR SWITCH Note: BARRIER, MOISTURE	00	1
20	410635	FASTENER Note: FASTENER, PIN	00	1
21	214813	LEVER FOR LID SWITCH Note: LEVER, LID SWITCH	00	1
22	214805	PIN FOR UNBALANCE LEVER Note: PIN, UNBALANCE LEVER	00	1
23	215236	UNBALANCE LEVER Note: LEVER, UNBALANCE	00	1
24	204968	PLUNGER & BRACKET ASSEMBLY	00	1
25	213718	LID SWITCH PLUNGER Note: PLUNGER, LID SWITCH	00	1
26	213720	SPRING Note: SPRING, LEVER	00	1
27	211500	WASHER,BRACKE TO TOP COVER Note: WASHER, BRACKET	00	2
28	910182	SCREW Note: SCREW	00	2
29	207159	SCREW Note: SCREW	00	1
30	N 207172	TOP COVER Note: TOP COVER (WHT)	11	1
30	N 207172M	TOP COVER ASSY HVT WHEAT Note: (H. WHEAT)	11	1
30	N 207172L	TOP COVER ASSY ALM---NA Note: (ALM)	11	1
31	215704	UNBALANCE LEVER	11	1
32	N 215700	LID SWITCH PLUNGER Note: PLUNGER, LID SWITCH	11	1
33	Y215699	BRACKET,SWITCH & FUSE Note: BRACKET, SWITCH & FUSE	11	1

*Color Code (-)=Not Shown #=Series, Serial Prefix or Run No., N=Not Available

Section: CABINET

Model: GA104

Section: CABINET
Models: ALL MODELS

P/N 160002

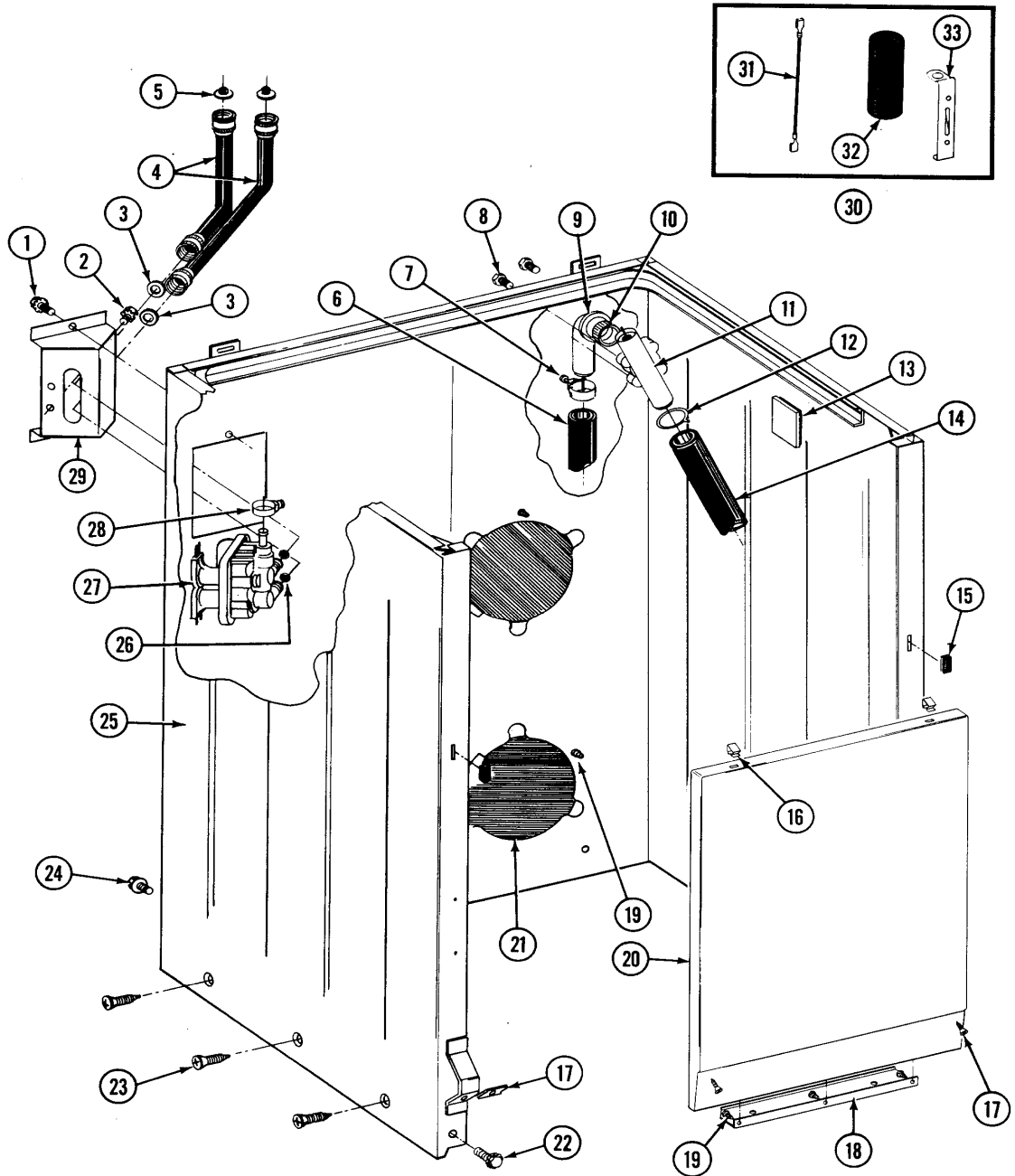

11/91

16

MA67D3

Section: CABINET

No.	Part No.	Description	Series	Qty
1	212276	SCREW	00	1
2	N 313561	SCREW----NA	00	2
3	Y013783	GASKET, INLET HOSE Note: WASHER, INLET HOSE	00	2
4	202860	INLET HOSE ASSY. Note: INLET HOSE ASSEMBLY	00	2
5	200961	SCREEN WASHER, INLET HOSE	00	2
6	215279	HOSE, DRAIN	00	1
7	200461	HOSE CLAMP - 1-5/8 INCH Note: CLAMP, HOSE (1-5/8 INCH)	00	1
8	Y014874	SCREW	00	4
9	214764	SIPHON BREAK ELBOW Note: ELBOW, SIPHON BREAK	00	1
10	214765	GASKET, SIPHON BREAK	00	1
11	206638	SIPHON BREAK(W/CLAMP) Note: BREAK, SIPHON (W/CLAMP)	00	1
12	200461	HOSE CLAMP - 1-5/8 INCH Note: CLAMP, HOSE (1-5/8 INCH)	00	1
13	215058	PAD, CABINET BUMPER	00	2
14	214767	HOSE,PUMP TO SIPHON BREAK Note: HOSE, PUMP	00	1
15	214376	SPACER, FRONT PANEL	00	2
16	212982	FASTENER, PANEL	00	2
17	204439	SCREW & FSTNER ASSY(FRT.PANEL) Note: SCREW & FSTNER ASSY (FT.PNL)	00	2
18	213846	GUARD, BELT	00	1
19	211294	SCREW	00	5
20	N 212998M	FRONT PANEL-HARVEST WHEAT Note: (H. WHEAT)	00	1
21	N 211878	PLATE, ACCESS	00	2
22	213122	SCREW,CBNT.TO FRNT OF BASE--NA Note: SCREW, CABINET (FRONT)	00	2
23	213007	SCREW, CABINET	00	6
24	213121	SCREW	00	3
25	N 203319M	CABINET-HARVEST WHEAT Note: (H. WHEAT)	00	1
26	214337	SCREEN, VALVE	00	2
27	205613	WATER VALVE Note: VALVE, WATER	00	1
28	201575	HOSE CLAMP Note: CLAMP, HOSE	00	1
29	214812	BRACKET,WATER VALVE Note: BRACKET, WATER VALVE	00	1
30	206103	CAPACITOR KIT	00	1
31	203237	#17 WIRE WITH TERMINAL Note: #17 WIRE W/TERMINAL	00	1
32	200832	CAPACITOR	00	1
33	211149	CLIP, CAPACITOR	00	1

*Color Code (-)=Not Shown #=Series, Serial Prefix or Run No., N=Not Available

Section: TUB\WATER INLET

Model: GA104

Section: TUB-WATER INLET & TUB COVER

P/N 160002

Models: ALL MODELS

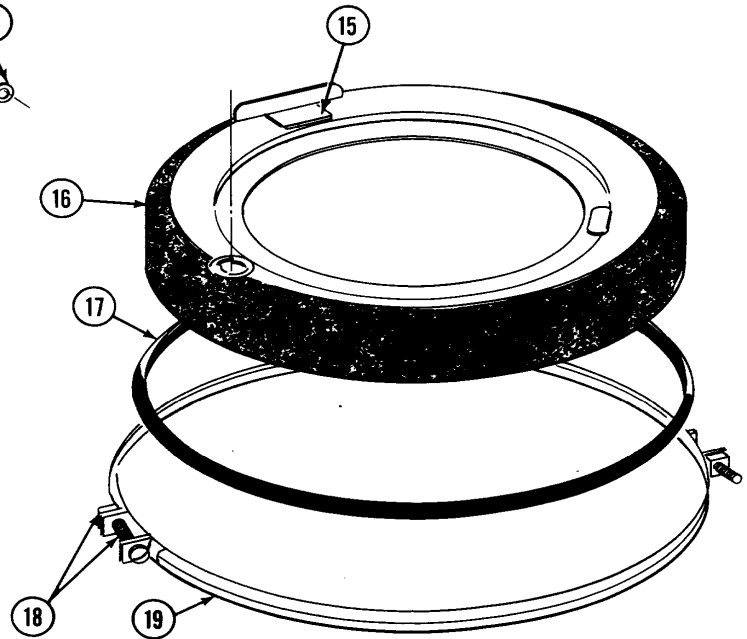
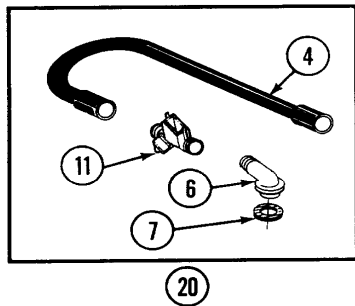
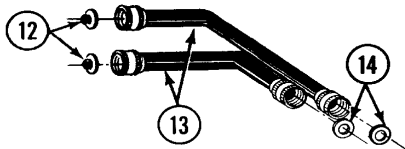
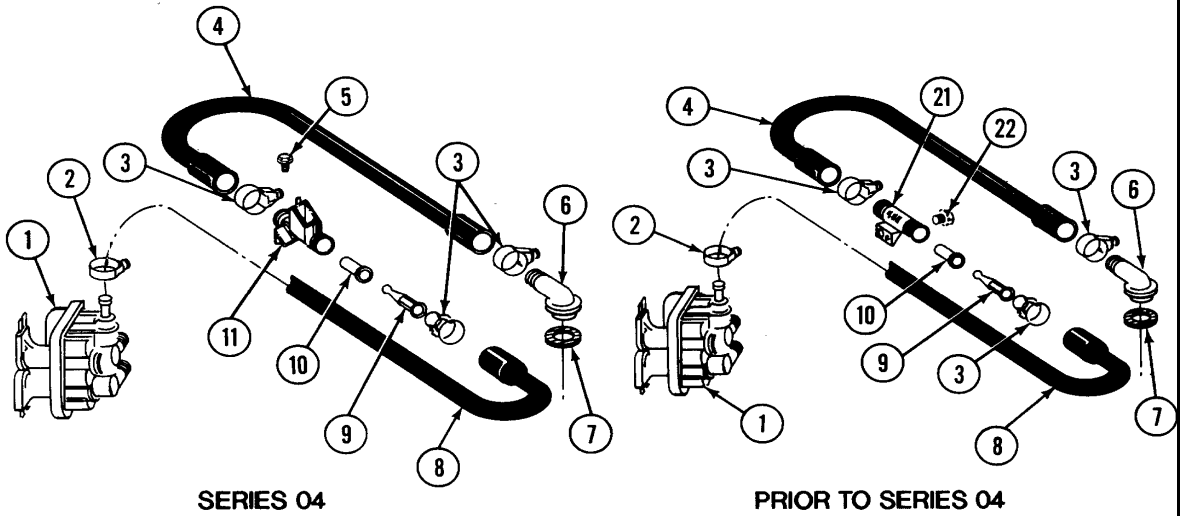

11/91

18

MA67D5

Section: TUB\WATER INLET

No.	Part No.	Description	Series	Qty
1	205613	WATER VALVE Note: VALVE, WATER	00	1
2	201575	HOSE CLAMP Note: CLAMP, HOSE	00	1
3	202515	HOSE CLAMP - 1-1/16 INCH Note: CLAMP, HOSE (1-1/16 INCH)	00	3
4	215234	INJECTOR FILL HOSE Note: HOSE, INJECTOR FILL	00	1
5	312620	SEMS SCREW, #10-16 X 1/2"	00	1
6	215235	INJECTOR TUBE Note: TUBE, INJECTOR	00	1
7	215233	SEAL FOR INJECTOR TUBE Note: SEAL, INJECTOR TUBE	00	1
8	213013	HOSE, INJECTOR Note: HOSE, INJECTOR	00	1
9	213015	INJECTOR NOZZLE Note: NOZZLE, INJECTOR	00	1
10	213016	VALVE FOR INJECTOR SUB Note: VALVE, INJECTOR	00	1
11	215447	SLEEVE FOR INJECTOR Note: SLEEVE, INJECTOR	04	1
12	200961	SCREEN WASHER, INLET HOSE	00	2
13	202860	INLET HOSE ASSY. Note: INLET HOSE ASSEMBLY	00	2
14	Y013783	GASKET, INLET HOSE Note: WASHER, INLET HOSE	00	2
15	215232	UNBALANCE BUMPER Note: BUMPER, UNBALANCE	00	1
16	206380	TUB COVER Note: COVER, TUB	00	1
17	211232	SEAL	00	1
18	205529	NUT & BOLT KIT FOR TUB CLAM Note: NUT & BOLT KIT, TUB CLAM	00	2
19	200846	CLAMP - TUB COVER Note: CLAMP, TUB COVER	00	2
20	206683	INJECTOR HOSE KIT	00	1
21	213057	SLEEVE FOR INJECTOR Note: SLEEVE, INJECTOR	00	1
22	310632	SCREW	00	1

*Color Code (-)=Not Shown #=Series, Serial Prefix or Run No., N=Not Available

Section: TUB (INNER & OUTER)

Model: GA104

Section: TUB-INNER & OUTER

P/N 160002

Models: ALL MODELS

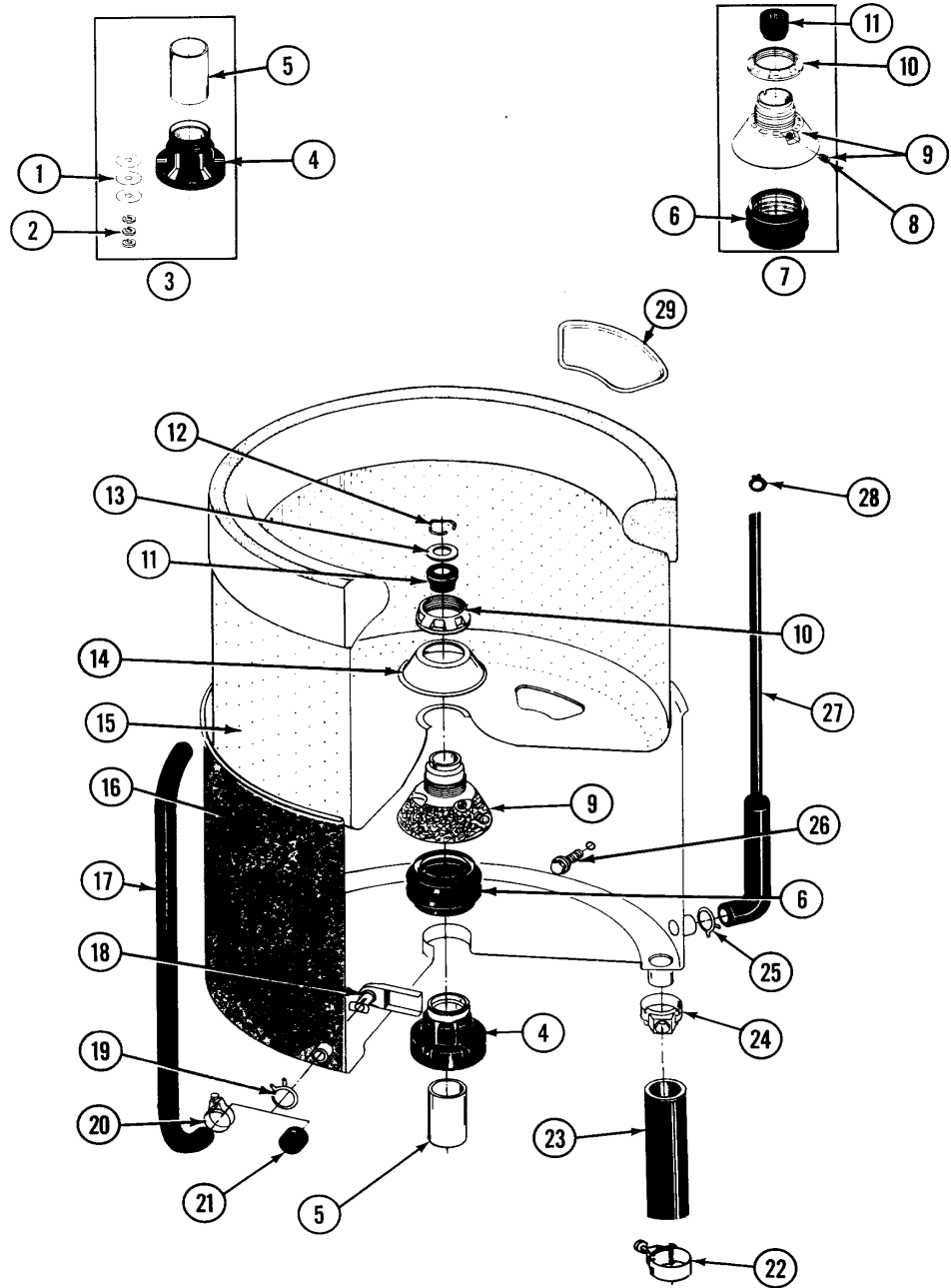

11/91

20

MA67D7

Section: TUB (INNER & OUTER)

No.	Part No.	Description	Series	Qty
1	211100	WASHER, CUSHION	00	3
2	Y054867	WASHER, LOCK	00	3
3	204013	TUB BEARING REPAIR KIT	00	1
4	200824	BEARING, TUB	00	1
5	211130	LINER, TUB BEARING	00	1
6	201537	SEAL AND SPRING Note: SEAL & SPRING	00	1
7	204012	MOUNTING STEM REPAIR KIT	00	1
8	211618	SET SCREW, MTG. STEM	00	1
9	202521	MOUNTING STEM Note: STEM, MOUNTING	00	1
10	211047	NUT, CLAMPING (INNER TUB)	00	1
11	Y0A4298	SEAL, AGITATOR DRIVE SHAFT	00	1
12	Y015667	RETAINING RING	00	1
13	015666	WASHER,RETAINING(CENTER SEAL)- Note: WASHER, RETAINING (CNTR SL)	00	1
14	211210	WASHER,CLAMPING NUT(STAINLESS) Note: WASHER, CLAMPING NUT	00	1
15	N 201523	INNER TUB Note: TUB, INNER	00	1
16	205486	TUB, OUTER	00	1
18	214434	SPOUT, DEFLECTOR	00	1
19	214739	SPRING HOSE CLAMP Note: CLAMP, SPRING HOSE	00	1
20	205161	CLAMP - 15/16" Note: CLAMP, BLEACH HOSE	00	1
21	214725	CAP FOR SPOUT-OUTER TUB Note: CAP, SPOUT (OUTER TUB)	00	1
22	200461	HOSE CLAMP - 1-5/8 INCH Note: CLAMP, HOSE (1-5/8 INCH)	00	1
23	Y212989	HOSE, OUTER TUB TO PUMP Note: HOSE, OUTER TUB	00	1
24	200900	CLAMP, SPRAY ARM HOSE	00	1
25	211641	CLAMP, 1-1/16" Note: CLAMP (1-1/16")	00	1
26	200744	BOLT & GASKET ASSY.(SHORT)	00	1
26	205254	BOLT & GASKET ASSEMBLY (LONG)	00	2
27	212942	AIR DOME AND TUBE Note: AIR DOME & TUBE	00	1
28	410296	CLAMP,WATER LEVEL SWTCH TUBE Note: CLAMP, WATER LVL SWITCH TUBE	00	1

*Color Code (-)=Not Shown #=Series, Serial Prefix or Run No., N=Not Available

Section: TRANSMISSION (HELICAL DRIVE)

Model: GA104

Section: TRANSMISSION-HELICAL DRIVE
Models: ALL MODELS

P/N 1600021

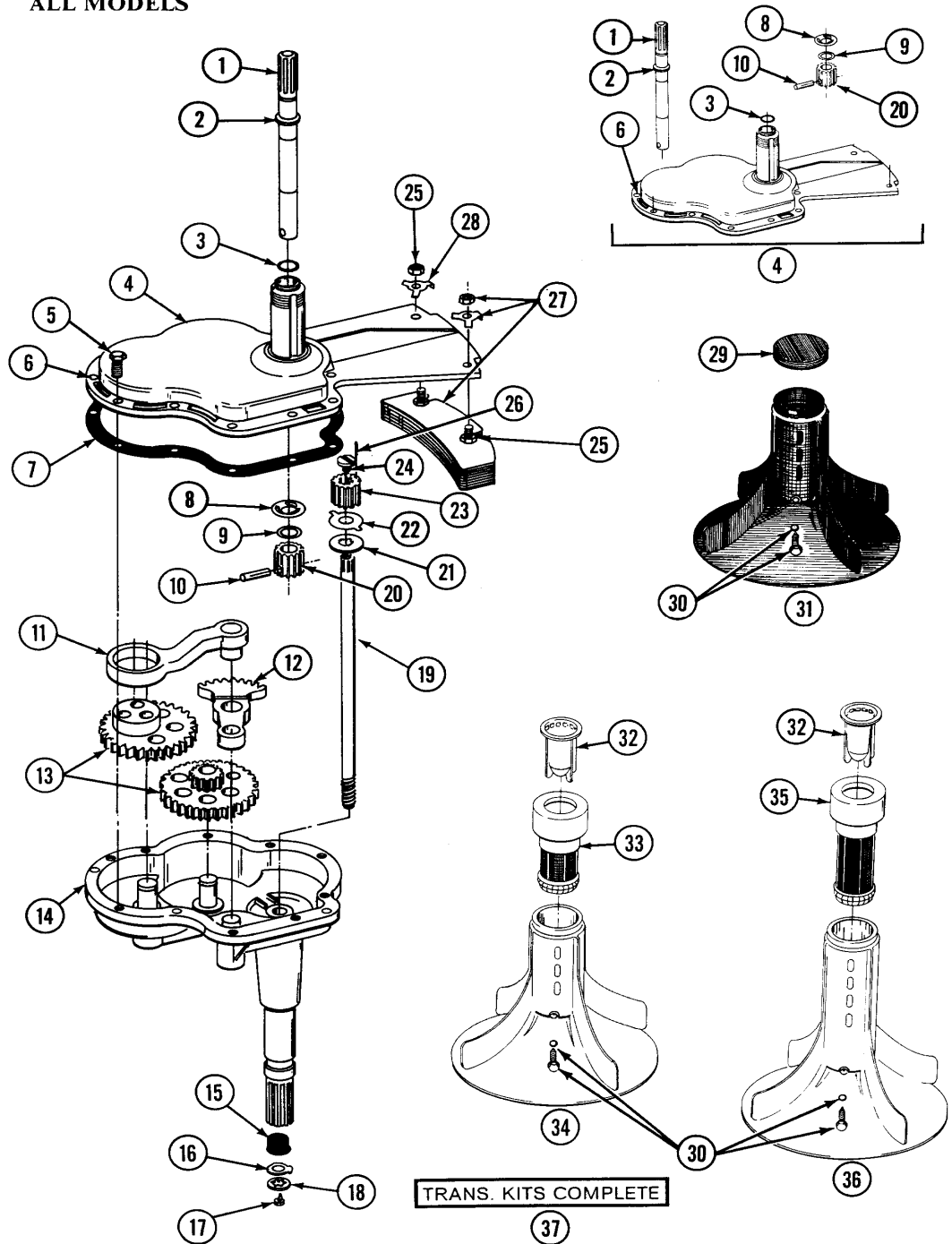

11/91

Section: TRANSMISSION (HELICAL DRIVE)

No.	Part No.	Description	Series	Qty
1	200730	AGITATOR SHAFT Note: SHAFT, AGITATOR	00	1
2	014839	COLLAR-DRIVE SHAFT Note: COLLAR, DRIVE SHAFT	00	1
3	210690	SEAL, RUBBER	00	1
4	N 200813	GEAR CASE COVER ASSEMBLY	00	1
5	Y015629	BOLT, GRINDING CHAMBER-DRAI Note: BOLT, GRINDING CHAMBER	00	10
6	N 015639	DOWEL PIN Note: PIN, DOWEL	00	2
7	210632	GASKET	00	1
8	Y015902	SPRING FOR AGITATOR Note: SPRING, AGITATOR	00	1
9	Y014827	WASHER-CENTER SHAFT Note: WASHER, CENTER SHAFT	00	1
10	210183	GROOV-PIN, 1/4 X 1-1/4 Note: GROOV-PIN, 1/4 X 1-1/4	00	1
11	N 201463	PITMAN WITH WRIST PIN Note: PITMAN W/WRIST PIN	00	1
12	N 210670	SEGMENT Note: SEGMENT	00	1
13	204967	GEAR KIT-POWER FIN AGITATOR	00	1
14	N 203162	GEAR HOUSING W/STUDS & TUBE	00	1
15	206602	SEAL, LIP (CENTER SHAFT) Note: SEAL, LIP (CNTR SHFT)	00	1
16	211089	LUG, STOP	00	1
17	211375	SCREW,STOP LUG(CENTER SHAFT) Note: SCREW,STOP LUG (CNTR SHAFT)	00	1
18	211090	WASHER, LOCK	00	1
19	212988	CENTER SHAFT Note: SHAFT, CENTER	00	1
20	210054	PINION Note: PINION	00	1
21	211483	WASHER, SPLINED	00	1
22	211484	LUG WASHER Note: WASHER, LUG	00	1
23	210315	PINION Note: PINION	00	1
24	211486	SCREW, 3/8-16 X 1/2 INCH	00	1
25	Y052740	NUT Note: NUT, COUNTERWEIGHT	00	4
26	N 211487	GROOV-PIN	00	1
27	N 205811	COUNTERWEIGHT	00	1
28	N 210172	LOCK WASHER Note: WASHER, LOCK	00	2
29	214705	AGITATOR CAP Note: CAP, AGITATOR	00	1
30	206478	SCREW & WASHER FOR AGITATOR Note: SCREW & WASHER, AGITATOR	00	1
31	201379	AGITATOR - BLACK Note: AGITATOR, BLACK	00	1
32	212815	DISPENSER CUP Note: CUP, DISPENSER	00	1
33	203320	LINT FILTER - DISPENSER Note: FILTER, LINT	00	1
34	205054	AGITATOR Note: AGITATOR, TURQUOISE	00	1
37	203383	TRANS & CENTER ASSM. REG TU Note: TRANS & CENTER ASSM. (REG)	00	1

*Color Code (-)=Not Shown #=Series, Serial Prefix or Run No., N=Not Available

Section: TRANSMISSION-ORBITAL

Model: GA104

Section: TRANSMISSION-ORBITAL

P/N 1600021

Models: ALL MODELS

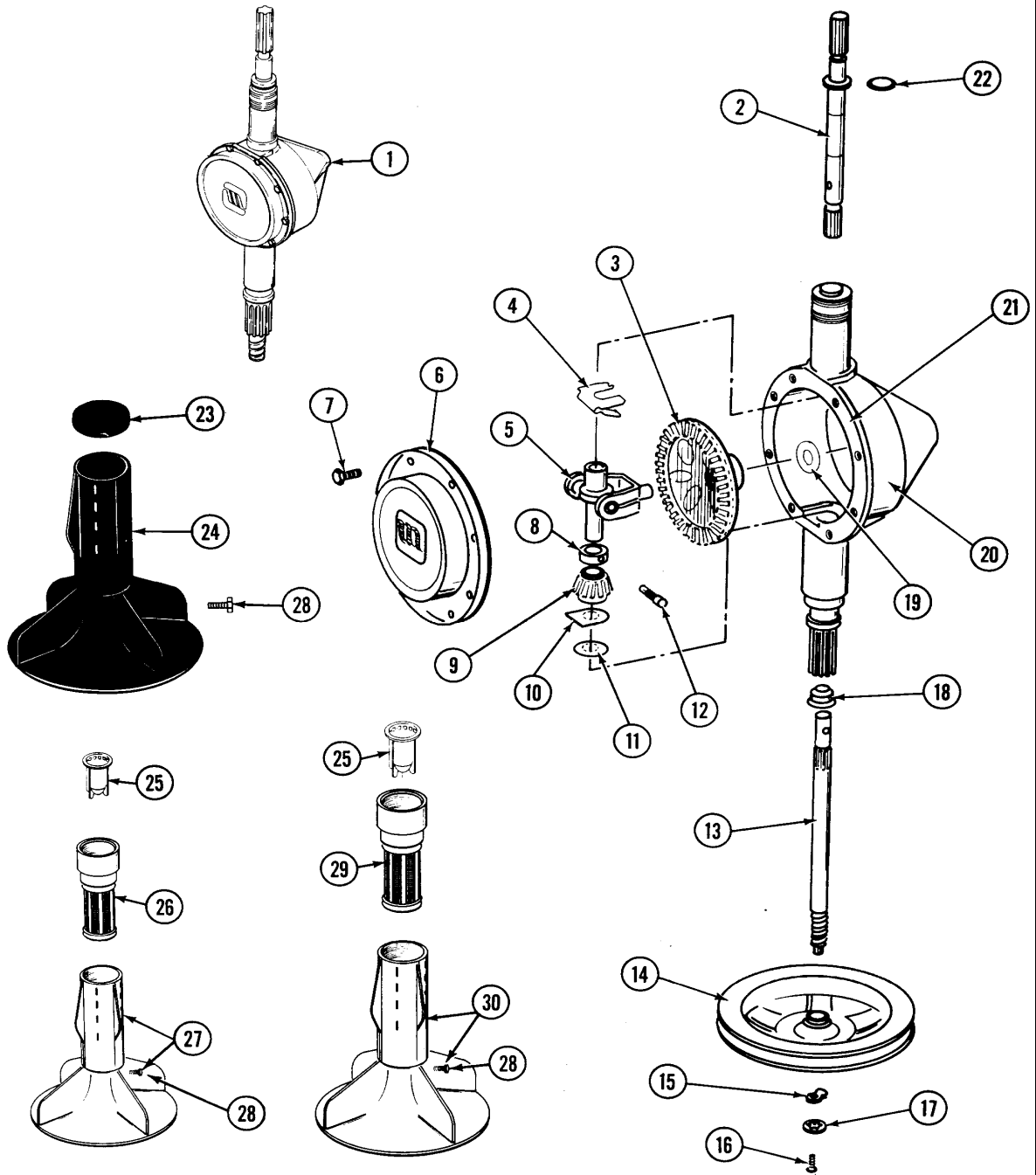

11/91

24

MA67D11

Section: TRANSMISSION-ORBITAL

No.	Part No.	Description	Series	Qty
1	206708	TRANSMISSION	10	1
2	207153	SHAFT, AGITATOR (W/SPRING)	10	1
3	206713	GEAR, BEVEL	10	1
4	215581	SPRING, AGITATOR SHAFT	10	1
5	206685	BLOCK, TORQUE AND YOKE ASSEMBL Note: TORQUE, BLOCK & YOKE	10	1
6	206628	COVER, TRANSMISSION	10	1
7	215417	SCREW, TRANSMISSION COVER	10	8
8	215415	COLLAR, LOWER	10	1
9	215401	PINION	10	1
10	215395	PLATE, CLUTCH	10	1
11	211483	WASHER, SPLINED	10	1
12	206629	PIN, COLLAR	10	1
13 N	215411	SHAFT, CENTER	10	1
14	211059	PULLEY, DRIVE	10	1
15	211089	LUG, STOP	10	1
16	211375	SCREW,STOP LUG(CENTER SHAFT) Note: SCREW,STOP LUG (CNTR SHAFT)	10	1
17	211090	WASHER, LOCK	10	1
18	206602	SEAL, LIP (CENTER SHAFT)	10	1
19	215394	WASHER, BEVEL GEAR	10	1
20	206625	HOUSING, TRANSMISSION	10	1
21	Y058700	SILASTIC,ADH.SEALANT Note: SILASTIC, ADH. SEALANT	10	1
22	210690	SEAL, RUBBER	10	1
23	215532	AGITATOR CAP - BLACK Note: AGITATOR CAP, BLACK	10	1
24	207119	AGITATOR W/LOCK SCREW	10	1
25	215733	DISPENSING CUP Note: CUP, DISPENSING	10	1
26	Y207427	LINT FILTER SHALLOW Note: FILTER, LINT SHALLOW	10	1
27	207538	AGITATOR W/LOCK SCREW	10	1
28	206478	SCREW & WASHER FOR AGITATOR Note: SCREW & WASHER, AGITATOR	10	1

*Color Code (-)=Not Shown #=Series, Serial Prefix or Run No., N=Not Available

Section: BASE

Model: GA104

Section: BASE

P/N 160002

Models: ALL MODELS

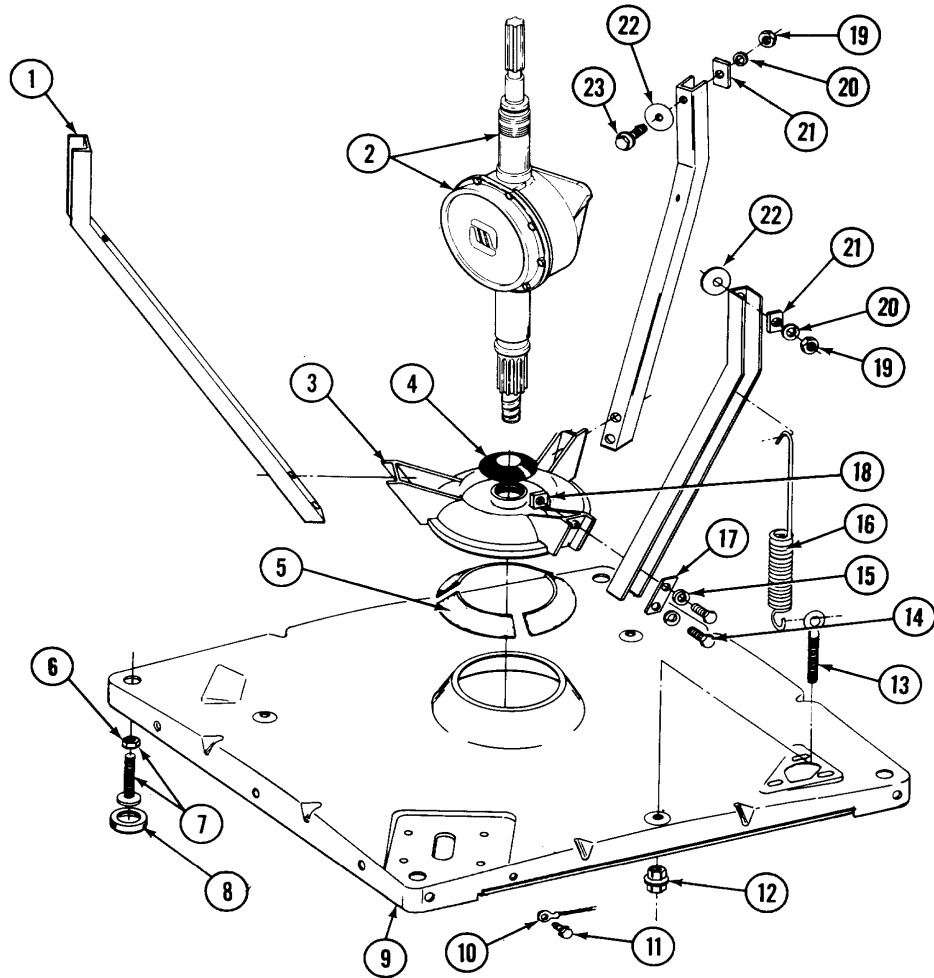

11/91

26

MA67D13

Section: BASE

No.	Part No.	Description	Series	Qty
1	213100	BRACE, TUB	00	3
2	206708	TRANSMISSION	00	1
3	203725	DAMPER W/BOLT & CLIP	00	1
4	211028	DEFLECTOR,WATER (DRIVE TUBE) Note: DEFLECTOR, WATER (DRIVE TUBE)	00	1
5	203956	DAMPER PAD KIT (W/POLY LUBE)	00	1
6	210385	NUT, LOCK	00	4
7	302699	LEG, ADJUSTABLE (W/NUT)	00	4
8	210684	FOOT, RUBBER	00	4
9	203274	BASE WITH DAMPER PADS Note: BASE W/DAMPER PADS	00	1
10	204807	GRND.WIRE,SUPP.PLTE TO TOP CVR Note: GROUND WIRE, SUPP. PLATE	00	1
11	210186	SCREW, GROUND WIRE TO BASE--NA Note: SCREW, GROUND WIRE	00	1
12	211949	NUT, EYEBOLT	00	3
13	213120	EYE BOLT FOR CENTER SPRING Note: EYE BOLT, CENTER SPRING	00	3
14	Y015627	SCREW, HEX HD CAP 5/16 X 5/8	00	6
15	911852	WASHER, LOCK (BRACE)	00	6
16	213054	CENTERING SPRING - 3 USED Note: CENTERING SPRING	00	3
17	213073	WASHER, DOUBLE Note: WASHER, DOUBLE (BRACE)	00	3
18	Y052785	NUT,BRACE TO DAMPER Note: NUT, BRACE (DAMPER)	00	6
19	Y052734	NUT Note: NUT, BRACE (TUB)	00	3
20	Y054867	WASHER, LOCK	00	3
21	212979	WASHER, TUB BRACE	00	3
22	211100	WASHER, CUSHION	00	3
23	205254	BOLT & GASKET ASSEMBLY (LONG)	00	2
23	200744	BOLT & GASKET ASSY.(SHORT) Note: BOLT & GASKET ASSEMBLY (SHORT)	00	1

*Color Code (-)=Not Shown #=Series, Serial Prefix or Run No., N=Not Available

Section: MOTOR & PUMP ASSY.

Model: GA104

Section: MOTOR & PUMP ASSEMBLY

P/N 1600021

Models: ALL MODELS

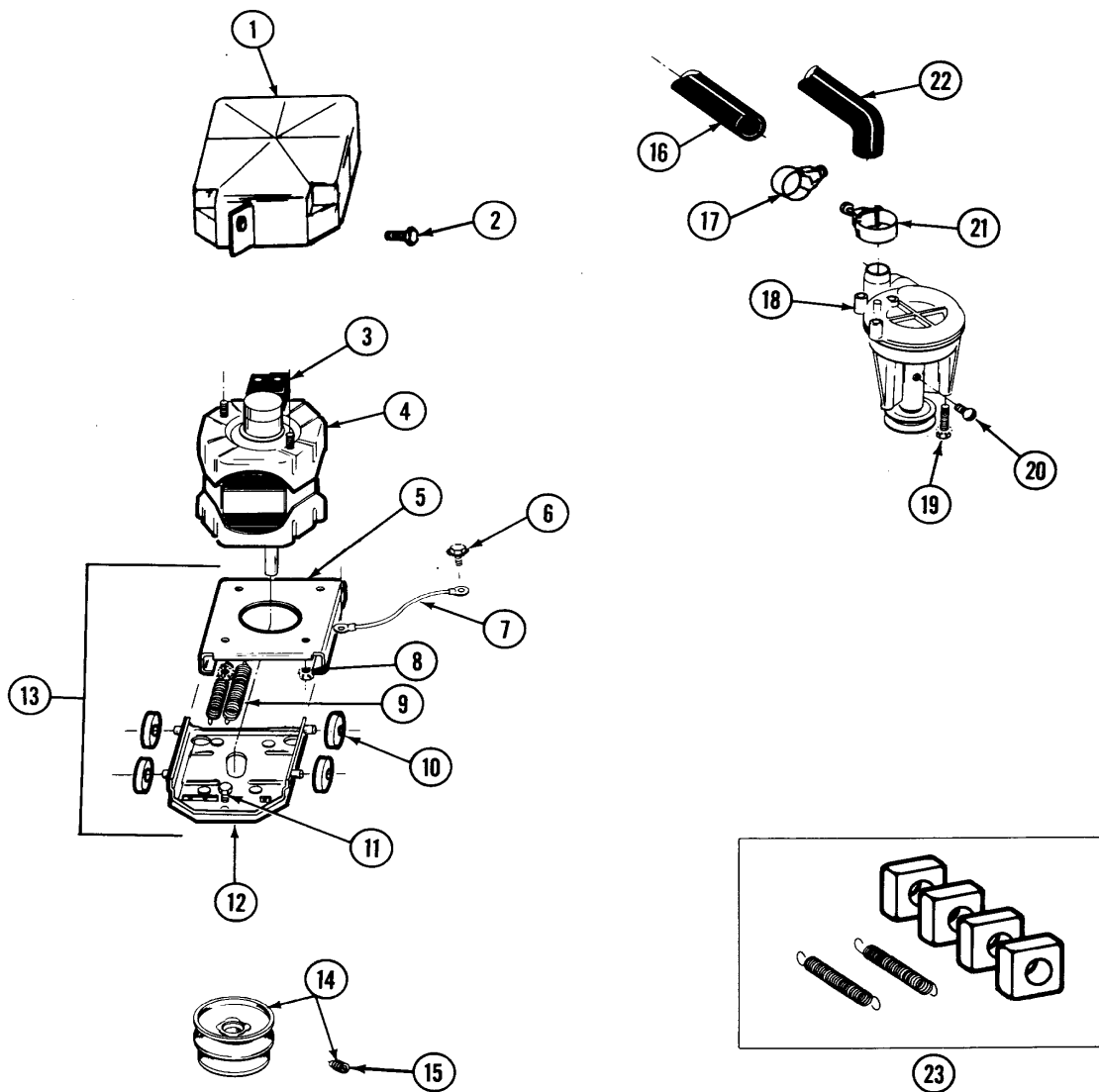

11/91

Section: MOTOR & PUMP ASSY.

No.	Part No.	Description	Series	Qty
1	215098	SHIELD, MOTOR	00	1
2	213121	SCREW	00	1
3	N 205133	MOTOR EXTERNAL START SWITCH Note: SWITCH, MOTOR START (PROD.#2-1664-8 & #2-5463)	00	1
3	206505	SWITCH, MOTOR START Note: (PROD. #2-1664-11, #2-1664-13 & #2-5463-1)	00	1
3	205132	SWITCH, MOTOR START Note: (PROD.#2-1664-4, #2-1664-9, #2-1664-10, #2-1664-12 & #2-5463-2)	00	1
4	201805	MOTOR (ONE SPEED)	00	1
5	214956	MOUNT, MOTOR/UPPER	00	1
6	210186	SCREW, GROUND WIRE TO BASE--NA Note: SCREW, GROUND WIRE	00	1
7	901220	WIRE, GROUND	00	1
8	311426	NUT, WASHERED LOCK Note: KEPS NUT, MOTOR BASE	00	4
9	202718	TENSION SPRINGS Note: SPRINGS, TENSION	00	1
10	204998	GLIDE KIT (4 W/POLY LUBE)	00	1
11	N 313561	SCREW---NA	00	3
12	205908	LOWER MOTOR MOUNT Note: MOUNT, LOWER MOTOR	00	1
13	205999	MOTOR MOUNT ASSM COMPLETE Note: MOTOR MOUNT ASSEMBLY	00	1
14	200816	PULLEY, MOTOR (W/SET SCREW)	00	1
15	Y053241	SET SCREW, PULLEY	00	1
16	214767	HOSE,PUMP TO SIPHON BREAK Note: HOSE, PUMP	00	1
17	200461	HOSE CLAMP - 1-5/8 INCH Note: CLAMP, HOSE (1-5/8 INCH)	00	1
18	202203	PUMP AS PAK	00	1
19	211880	SCREW, HEX HD #10 X 1/2 INC Note: SCREW, HEX HD #10 X 1/2"	00	3
20	Y015408	SCREW, BEARING INSERT	00	1
21	202574	CLAMP, HOSE Note: CLAMP, HOSE	00	1
22	Y212989	HOSE, OUTER TUB TO PUMP Note: HOSE, OUTER TUB	00	1
23	205000	GLIDE & SPRING KIT	00	1

*Color Code (-)=Not Shown #=Series, Serial Prefix or Run No., N=Not Available

Section: CLUTCH, BRAKE & BELTS

Model: GA104

Section: CLUTCH, BRAKE & BELTS

P/N 1600021

Models: ALL MODELS

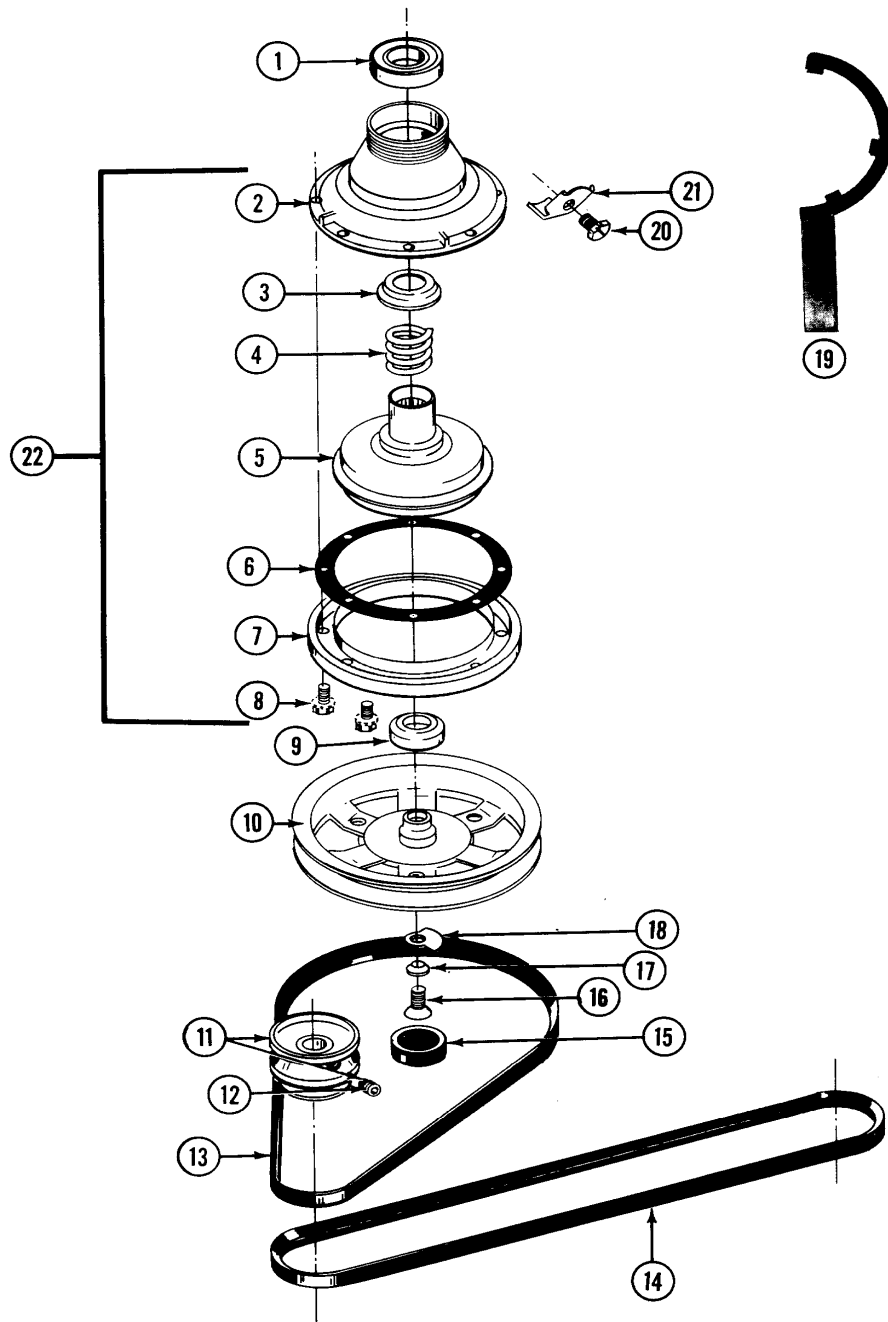

11/91

30

MA67E3

Section: CLUTCH, BRAKE & BELTS

No.	Part No.	Description	Series	Qty
1	200720	BALL BEARING, RADIAL	00	1
2	211045	HOUSING, BRAKE	00	1
3	211039	RETAINER, BRAKE SPRING	00	1
4	211041	SPRING, BRAKE	00	1
5	201126	ROTOR, BRAKE (W/FACING)	00	1
6	211042	GASKET, BRAKE DRUM	00	1
7	211043	DRUM, BRAKE	00	1
8	211000	SCREW,HEX HEAD (BRAKE DRUM) Note: SCREW, HEX HEAD (BRAKE DRUM)	00	8
9	200835	BEARING, BRAKE ROTOR	00	1
10	211059	PULLEY, DRIVE	00	1
11	200816	PULLEY, MOTOR (W/SET SCREW)	00	1
12	Y053241	SET SCREW, PULLEY	00	1
13	211125	V BELT,DRIVE PULLEY Note: V BELT, DRIVE PULLEY	00	1
14	211124	V BELT, PUMP	00	1
15	N 211038	CAP, OIL RETAINER	00	1
16	211375	SCREW,STOP LUG(CENTER SHAFT) Note: SCREW,STOP LUG (CNTR SHAFT)	00	1
17	211090	WASHER, LOCK	00	1
18	211089	LUG, STOP	00	1
19	Y038315	TOOL, BRAKE PKG ASSY	00	1
20	213326	SCREW, RETAINING CLIP Note: BOLT, RETAINING CLIP	00	1
21	213325	CLIP, RETAINER	00	1
22	201190	BRAKE ASSEMBLY	00	1

*Color Code (-)=Not Shown #=Series, Serial Prefix or Run No., N=Not Available