

# WASHER

## Repair Parts List

MODEL NUMBER  
GA25CS

When requesting service or ordering parts, always provide the following information:

- Product Type
- Part Number
- Model Number
- Part Description

**MAYTAG**®

©2005 Maytag Services

Section: CONTROL PANEL, TOP CVR & LID SWITCH (00)

Model: GA25CS

**MODEL A25CS**

**CS CONTROL PANEL, TOP COVER**

**& LID SWITCH**

**PRIOR TO SERIES 12**

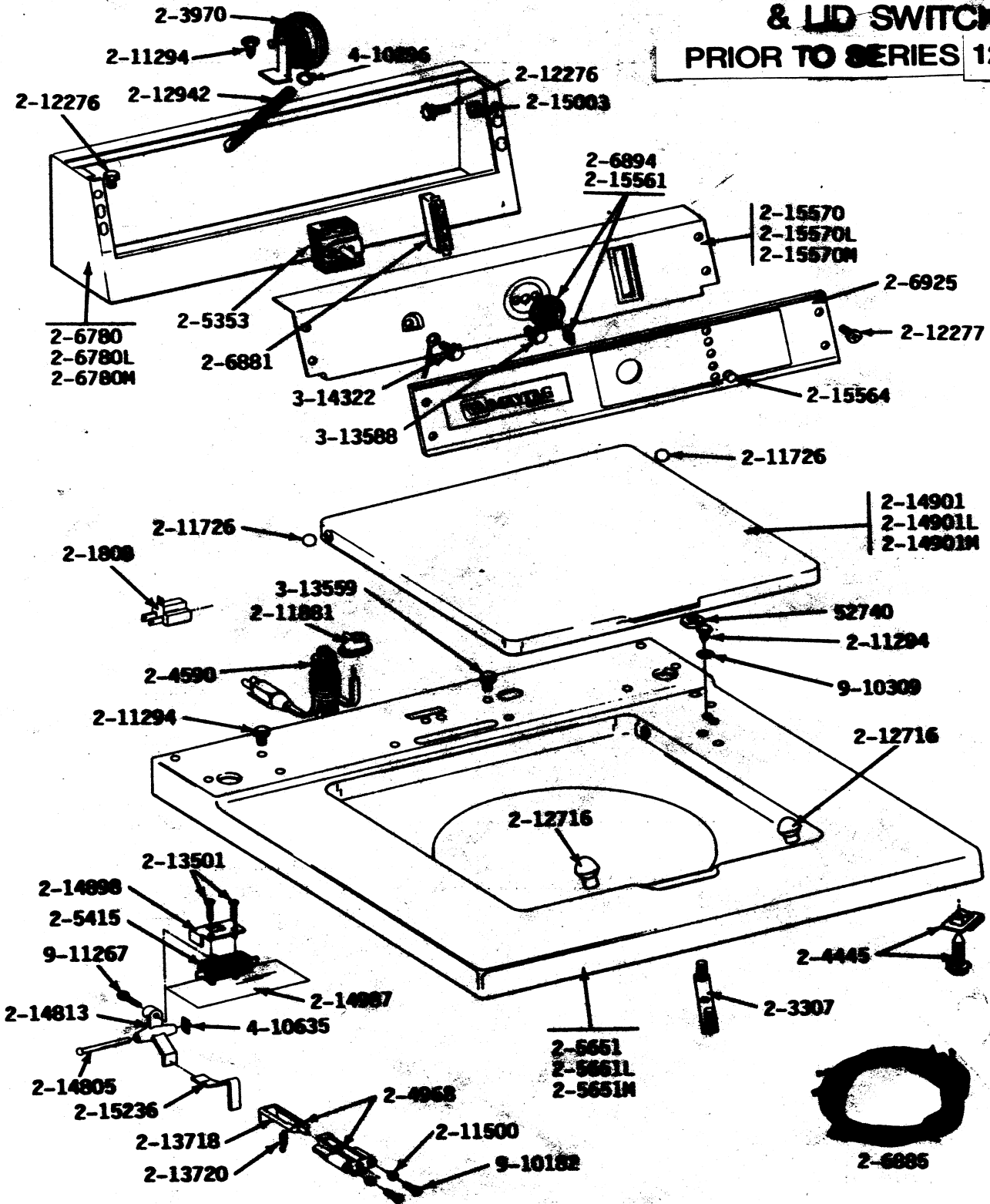

MA70A3

## Section: CONTROL PANEL, TOP CVR & LID SWTCH (0

No.	Part No.	Description	Series	Qty
1	052740	NUT	00	1
2	N 201808	CONVERTER	00	1
3	N 203307	MTG. STRAP----NA	00	1
4	203970	SWITCH	00	1
5	204445	SCREW & FASTENER ASY.	00	1
6	204590	POWER CORD	00	1
7	204968	PLUNGER & BRACKET ASSEMBLY	00	1
8	205353	SWITCH, TEMP.	00	1
9	205415	SWITCH, LID (W/O TUB LIGHT)	00	1
10	N 205651M	TOP COVER-HARVEST WHEAT	00	1
11	N 206780M	CONTROL COVER ASSY	00	1
12	211881	GROMMET, CORD	00	1
13	N 206885	WIRE HARNESS	00	1
14	206894	KNOB W/BUMP	00	1
15	N 206925	CONTROL PANEL WITH LENS - CS &	00	1
16	211294	SCREW	00	1
17	211500	WASHER,BRACKE TO TOP COVER	00	1
18	211726	HINGE, BALL	00	1
19	211881	GROMMET, CORD	00	1
20	212276	SCREW	00	1
21	212277	SCREW, #8 X 1/2 INCH	00	1
22	212716	BUMPER, LID	00	1
23	212942	AIR DOME AND TUBE	00	1
24	213501	SCREW, #6-20 X 1-1/8 INCH	00	1
25	213718	LID SWITCH PLUNGER	00	1
26	213720	SPRING	00	1
27	214805	PIN FOR UNBALANCE LEVER	00	1
30	N 214901M	LID-HARVEST WHEAT	00	1
31	214987	MOISTURE BARRIER FOR SWITCH	00	1
32	215003	FASTENER	00	1
33	215236	UNBALANCE LEVER	00	1
36	N 215570M	BACKUP PLATE - HARV WHEAT	00	1
37	313559	SCREW	00	1
38	313588	SCREW	00	1
39	314322	SCREW, #8-32 X 3/8 INCH	00	1
40	410296	CLAMP,WATER LEVEL SWTCH TUBE	00	1
41	410635	FASTENER	00	1
42	910182	SCREW	00	1
43	910309	WASHER	00	1
44	911267	SCREW, PUMP COVER	00	1

\*Color Code (-)=Not Shown #=Series, Serial Prefix or Run No., N=Not Available

Section: CONTROL PANEL, TOP CVR & LID SWITCH (12)

Model: GA25CS

**MODEL A25CS**

**CS CONTROL PANEL, TOP COVER**

**& LID SWITCH  
SERIES 12**

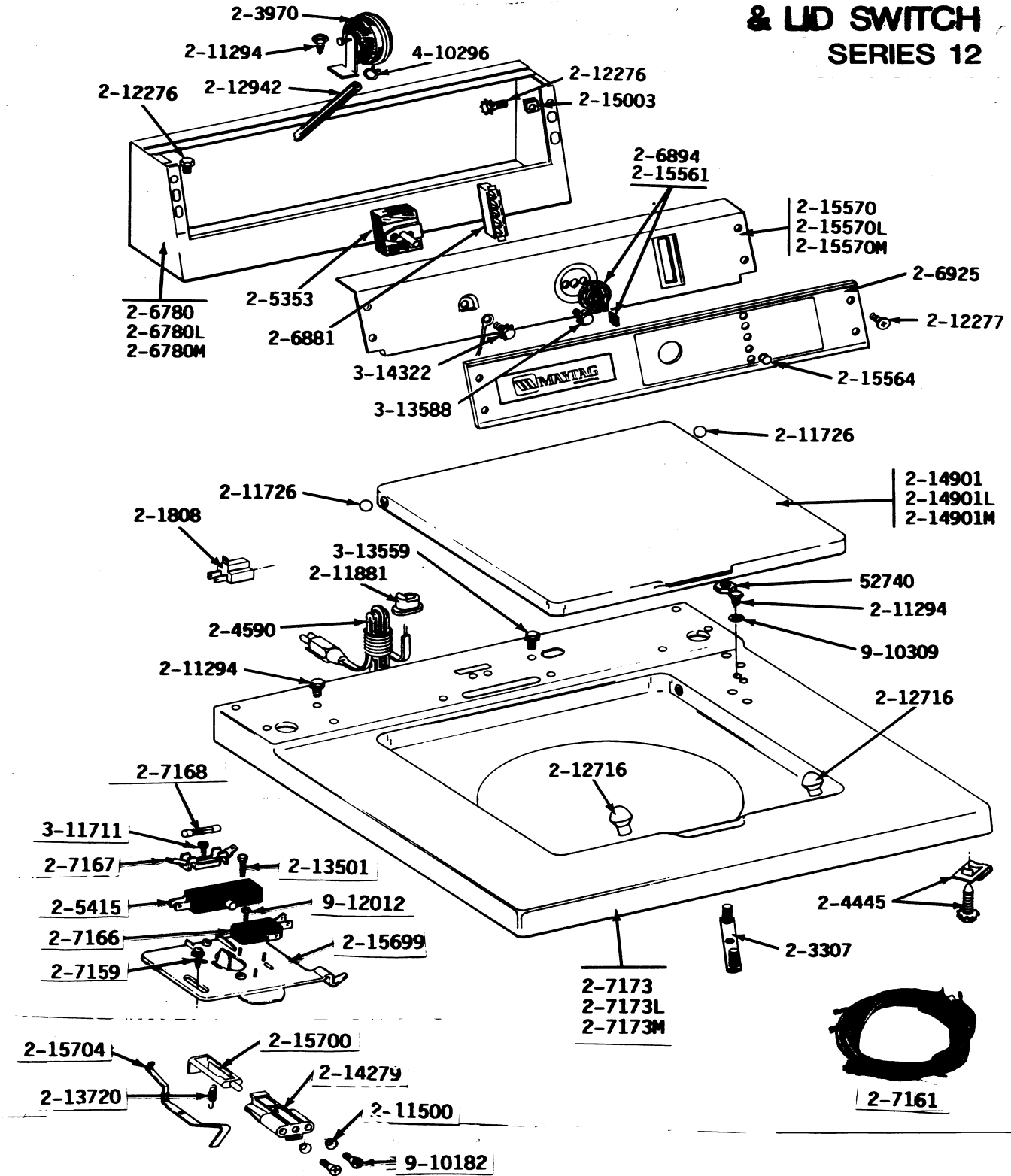

MA70A5

**Section: CONTROL PANEL, TOP CVR & LID SWTCH (1**

No.	Part No.	Description	Series	Qty
1	052740	NUT	12	1
2	N 201808	CONVERTER	12	1
3	N 203307	MTG. STRAP----NA	12	1
4	203970	SWITCH	12	1
5	204445	SCREW & FASTENER ASY.	12	1
6	204590	POWER CORD	12	1
7	205353	SWITCH, TEMP.	12	1
8	205415	SWITCH, LID (W/O TUB LIGHT)	12	1
9	N 206780M	CONTROL COVER ASSY	12	1
10	206881	INDICATOR, 5 LIGHT 115V	12	1
11	206894	KNOB W/BUMP	12	1
12	N 206925	CONTROL PANEL WITH LENS - CS &	12	1
13	207159	SCREW	12	1
14	207161	WIRE HARNESS	12	1
15	207166	SWITCH, CHECK	12	1
16	207167	BLOCK, FUSE	12	1
17	207168	FUSE	12	1
18	N 207173M	TOP COVER ASSY WVT WHEAT	12	1
19	211294	SCREW	12	1
20	211500	WASHER,BRACKE TO TOP COVER	12	1
21	211726	HINGE, BALL	12	1
22	211881	GROMMET, CORD	12	1
23	212276	SCREW	12	1
24	212277	SCREW, #8 X 1/2 INCH	12	1
25	212716	BUMPER, LID	12	1
26	212942	AIR DOME AND TUBE	12	1
27	213501	SCREW, #6-20 X 1-1/8 INCH	12	1
28	213720	SPRING	12	1
29	214279	BRACKET F/LID SWITCH PLUNGE	12	1
30	N 214901M	LID-HARVEST WHEAT	12	1
31	215003	FASTENER	12	1
32	215561	LID BUMPER	12	1
33	215564	LENS, INDICATOR (AMBER)	12	1
34	N 215570M	BACKUP PLATE - HARV WHEAT	12	1
35	215699	BRACKET,SWITCH & FUSE	12	1
36	N 215700	LID SWITCH PLUNGER	12	1
37	215704	UNBALANCE LEVER	12	1
38	311711	SCREW	12	1
39	313559	SCREW	12	1
40	313588	SCREW	12	1
41	314322	SCREW, #8-32 X 3/8 INCH	12	1
42	410296	CLAMP,WATER LEVEL SWTCH TUBE	12	1
43	910182	SCREW	12	1
44	910309	WASHER	12	1
45	912012	SCREW	12	1

\*Color Code (-)=Not Shown #=Series, Serial Prefix or Run No., N=Not Available

Section: CONTROL CENTER

Model: GA25CS

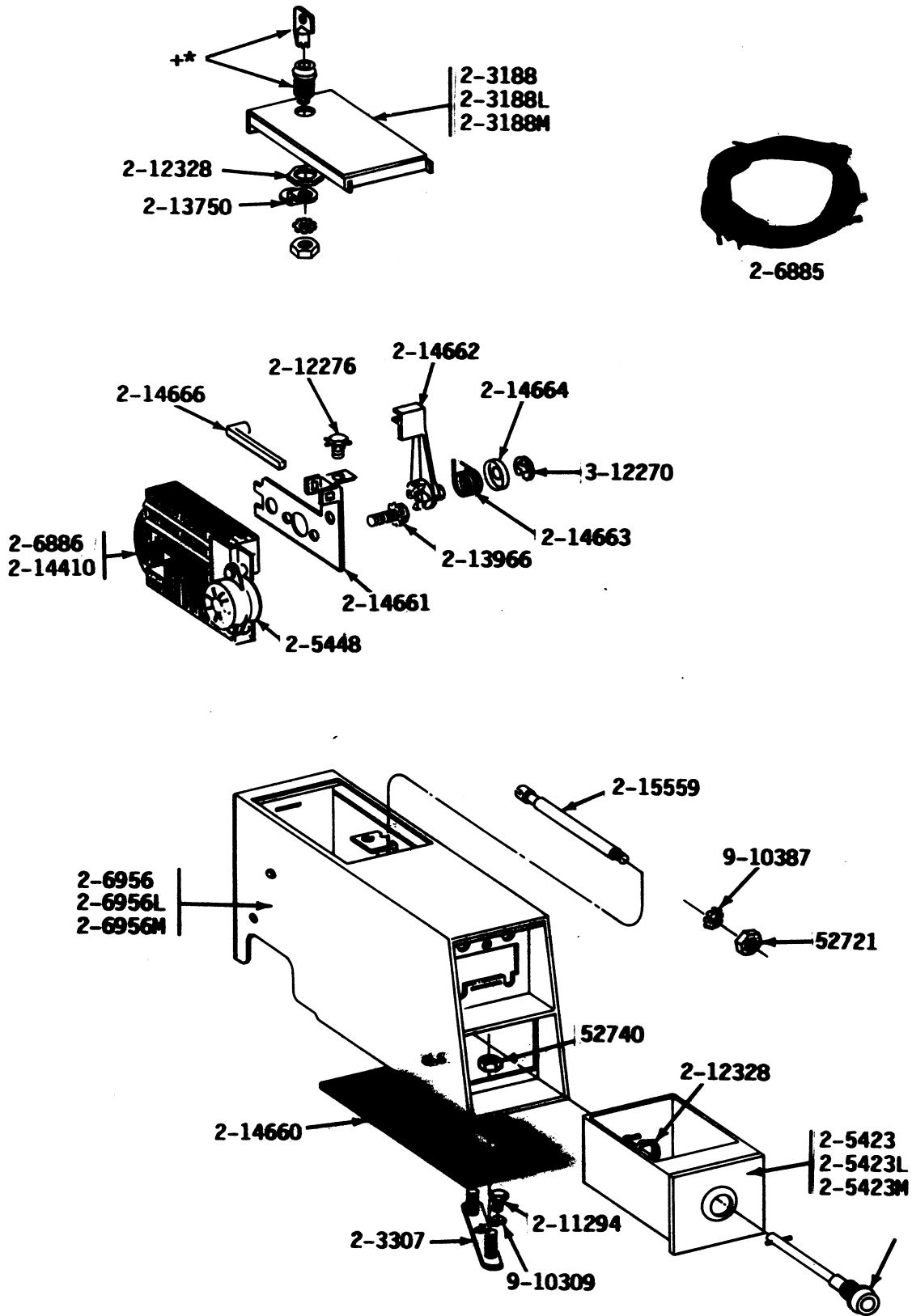

MA70A7

## Section: CONTROL CENTER

No.	Part No.	Description	Series	Qty
1	052721	NUT	00	1
2	052740	NUT	00	1
3	203188M	ACCESS DOOR-HARVEST WHEAT	00	1
4	N 203307	MTG. STRAP----NA	00	1
5	N 205423M	COIN BOX-HARVEST WHEAT	00	1
6	205448	TIMER MOTOR 120-60	00	1
7	N 206885	WIRE HARNESS	00	1
8	206886	TIMER	00	1
9	206917	TIMER & ACUTATOR ASY	00	1
10	N 206956M	COIN METER ASSY-HARV WHEAT--NA	00	1
11	211294	SCREW	00	1
12	212276	SCREW	00	1
13	212328	NUT, HEX	00	1
14	213750	LOCKING CAM	00	1
15	213966	SCREW-TIMER TO CONTROL PANE	00	1
16	214410	TIMER CAUTION LABEL	00	1
17	214660	GASKET, METER CASE	00	1
18	214661	BRACKET FOR TIMER	00	1
19	214662	PIVOT ARM FOR TIMER	00	1
20	214663	SPRING FOR TIMER LEVER	00	1
21	214664	SPRING RETAINER FOR TIMER	00	1
22	214666	ARM, ACTUATOR	00	1
23	215559	BOLT, LOCKING	00	1
24	312270	E CLIP	00	1
25	910309	WASHER	00	1
26	910387	LOCK WASHER	00	1

\*Color Code (-)=Not Shown #=Series, Serial Prefix or Run No., N=Not Available

Section: MAYTAG COIN SLIDE

Model: GA25CS

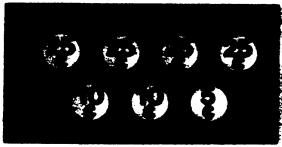

2-14648

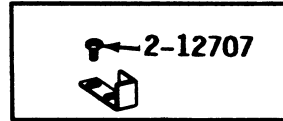

2-12707

2-5469

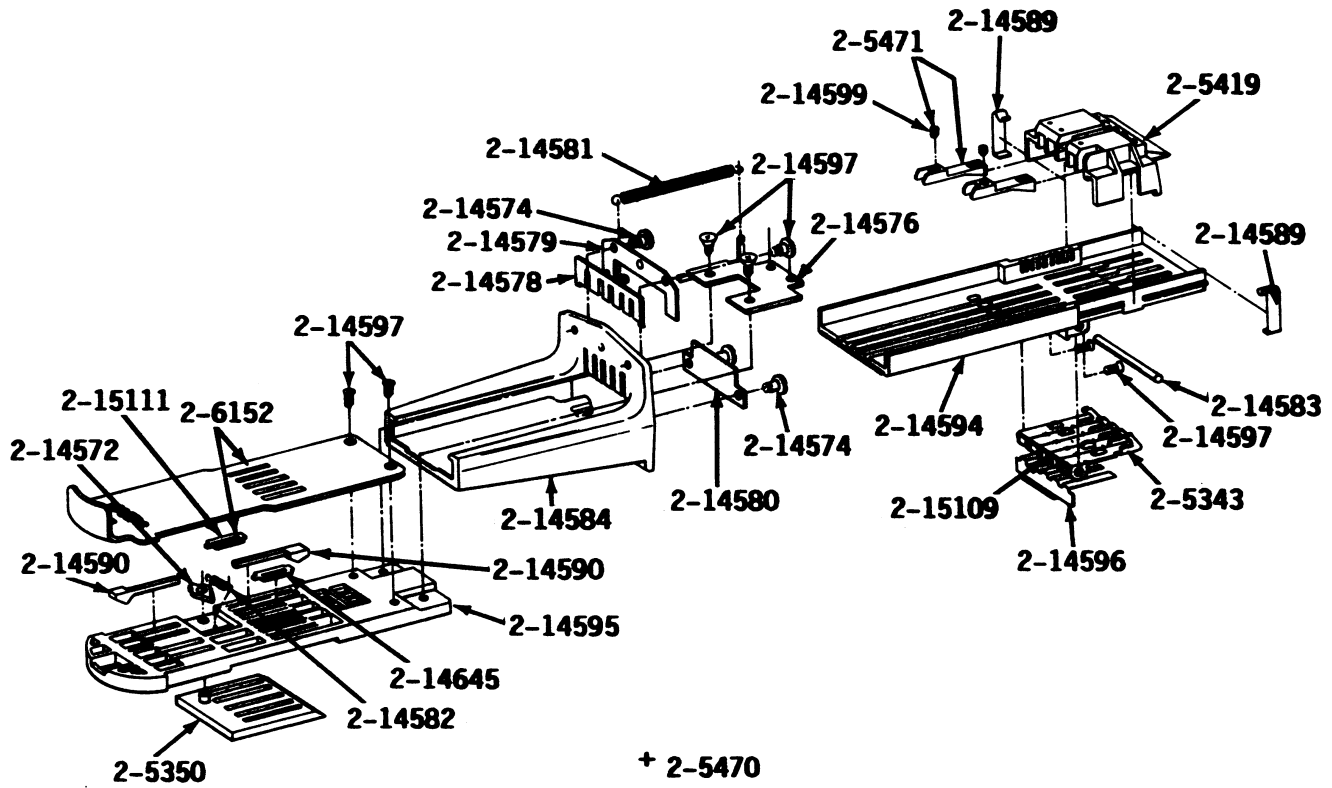

+ 2-5470  
Maytag Coin Slide  
Complete

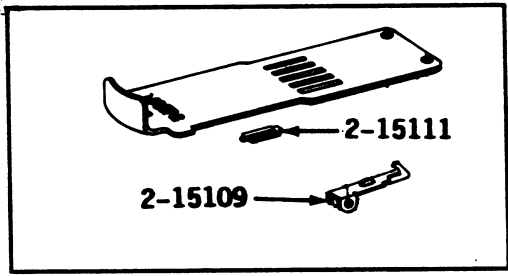

2-15111

2-15109

2-6152



## Section: MAYTAG COIN SLIDE

No.	Part No.	Description	Series	Qty
1	205343	LOWER GAGE ARM ASSEMBLY	00	1
2	205350	STOP BLOCK ASSEMBLY	00	1
3	N 205419	MEASURING BLOCK ASSEMBLY	00	1
4	205469	ACTUATOR KIT FOR COIN SLIDE	00	1
5	N 205470	MAYTAG COIN SLIDE	00	1
6	N 205471	MOVABLE COIN GAGE	00	1
7	N 206152	SLIDE PLATE W/NICKEL INSERT	00	1
8	212707	SCREW	00	1
9	214572	RATCHET ARM	00	1
10	N 214574	STUD FOR COIN SLIDE	00	1
11	N 214576	END BRACKET FOR SLIDE	00	1
12	214578	GATE FOR COIN OPENING	00	1
13	N 214579	RETAINER FOR GATE	00	1
14	N 214580	RETAINER FOR GAGE SPRING	00	1
15	214581	RETURN SPRING	00	1
16	214582	SPRING FOR RATCHET ARM	00	1
17	N 214583	PIN FOR LOWER GAGE ARM	00	1
18	214584	HOUSING FOR COIN SLIDE	00	1
19	214589	SPRING CLIP	00	1
20	N 214590	PLUG FOR COIN OPENING	00	1
21	214594	BASE INSERT FOR HOUSING	00	1
22	N 214595	SLIDE BODY	00	1
23	214596	SPRING FOR LOWER GAGE ARM	00	1
24	214597	SCREW	00	1
25	N 214599	SET SCREW FOR GAGE	00	1
26	N 214645	DIME INSERT	00	1
27	214648	COINAGE DECAL	00	1
28	N 215109	LOWER GAGE ARM	00	1
29	N 215111	NICKEL INSERT	00	1

\*Color Code (-)=Not Shown #=Series, Serial Prefix or Run No., N=Not Available

Section: CABINET, WATER VALVE, HOSES & FRNT PANEL

Model: GA25CS

**ALL MODELS**

**CABINET, WATER VALVE, HOSES AND FRONT PANEL**

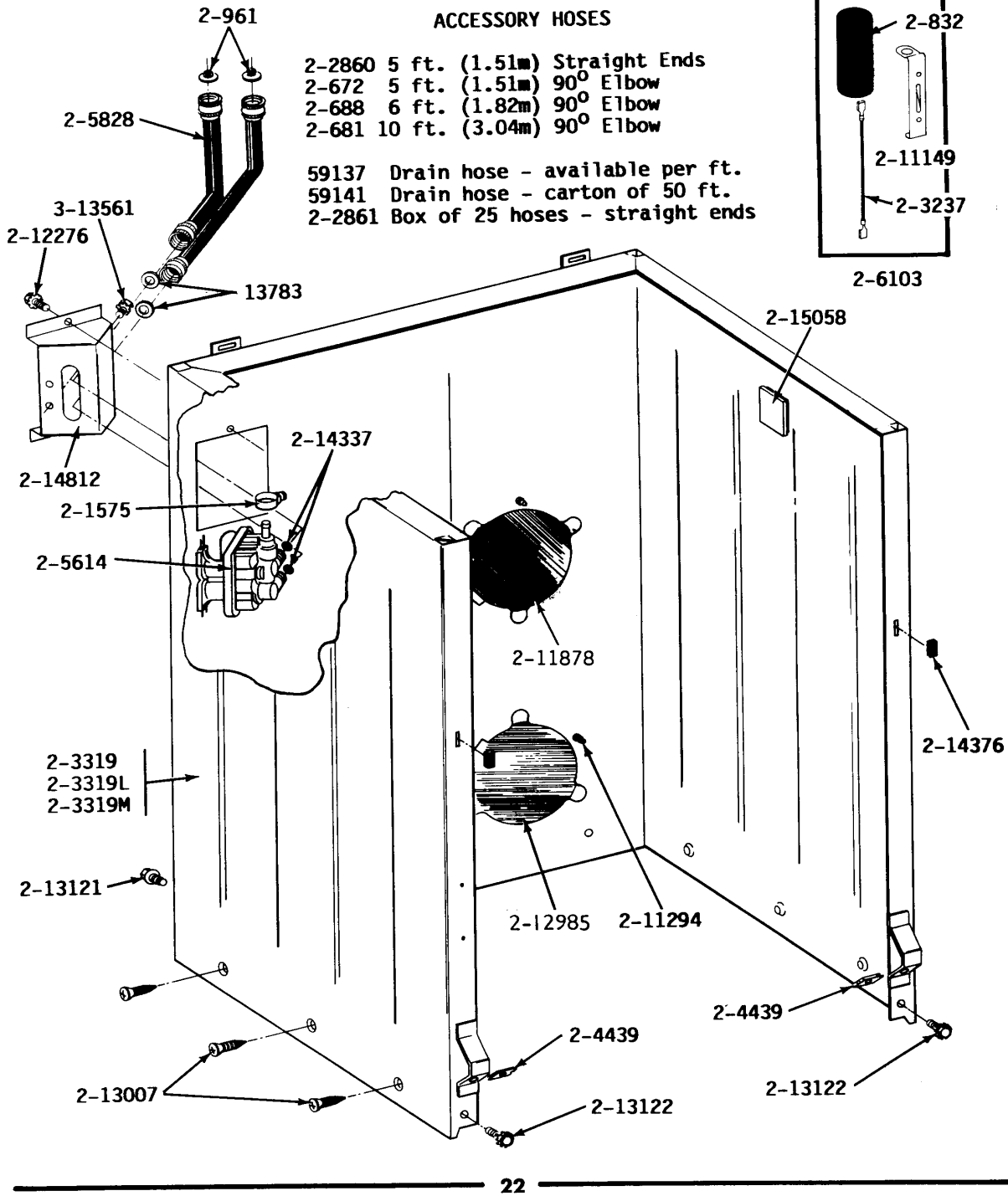

MA70B9

**Section: CABINET, WATER VALVE, HOSES & FRNT P**

No.	Part No.	Description	Series	Qty
1	013783	GASKET, INLET HOSE	00	1
2	N 059137	HOSE 31/32" PER FOOT BRANCH ST	00	1
3	059141	CTN. 50 FT. 31/32 DRAIN HOS	00	1
4	200461	HOSE CLAMP - 1-5/8 INCH	00	1
5	200672	INLET HOSE ASSY.	00	1
6	200681	INLET HOSE, HOT 10 FT.	00	1
7	200688	INLET HOSE, HOT 6 FT.	00	1
8	200832	CAPACITOR	00	1
9	200908	HOSE CLAMP - 1-1/2 INCH	00	1
10	200961	SCREEN WASHER, INLET HOSE	00	1
11	201112	SIPHON BREAK KIT	00	1
12	201575	HOSE CLAMP	00	1
13	202860	INLET HOSE ASSY.	00	1
14	202861	CARTON OF 25 HOSE, 5'	00	1
15	203237	#17 WIRE WITH TERMINAL	00	1
16	N 203319M	CABINET-HARVEST WHEAT	00	1
17	204439	SCREW & FSTNER ASSY(FRT.PANEL)	00	1
18	205614	WATER VALVE 120V 60HZ	00	1
19	205828	HOSE, INLET ASSY.	00	1
20	206103	CAPACITOR KIT	00	1
21	211111	HOSE COUPLING	00	1
22	211149	CLIP, CAPACITOR	00	1
23	211294	SCREW	00	1
24	211448	CLAMP	00	1
25	N 211878	PLATE, ACCESS	00	1
26	212276	SCREW	00	1
27	212982	FASTENER, PANEL	00	1
28	212985	PLATE, ACCESS (W/HOLE)	00	1
29	N 212998M	FRONT PANEL-HARVEST WHEAT	00	1
30	213007	SCREW, CABINET	00	1
31	213121	SCREW	00	1
32	213122	SCREW,CBNT.TO FRNT OF BASE--NA	00	1
33	213846	GUARD, BELT	00	1
34	214337	SCREEN, VALVE	00	1
35	214376	SPACER, FRONT PANEL	00	1
36	214768	DRAIN HOSE, 4 FOOT	00	1
37	214812	BRACKET,WATER VALVE	00	1
38	215057	DRAIN HOSE	00	1
39	215058	PAD, CABINET BUMPER	00	1
40	310842	SCREW	00	1
41	N 313561	SCREW----NA	00	1

\*Color Code (-)=Not Shown #=Series, Serial Prefix or Run No., N=Not Available

Section: TUB, AGITATOR, MOUNTING STEM & SEAL

Model: GA25CS

**ALL MODELS** TUB, AGITATOR, MOUNTING STEM AND SEALS

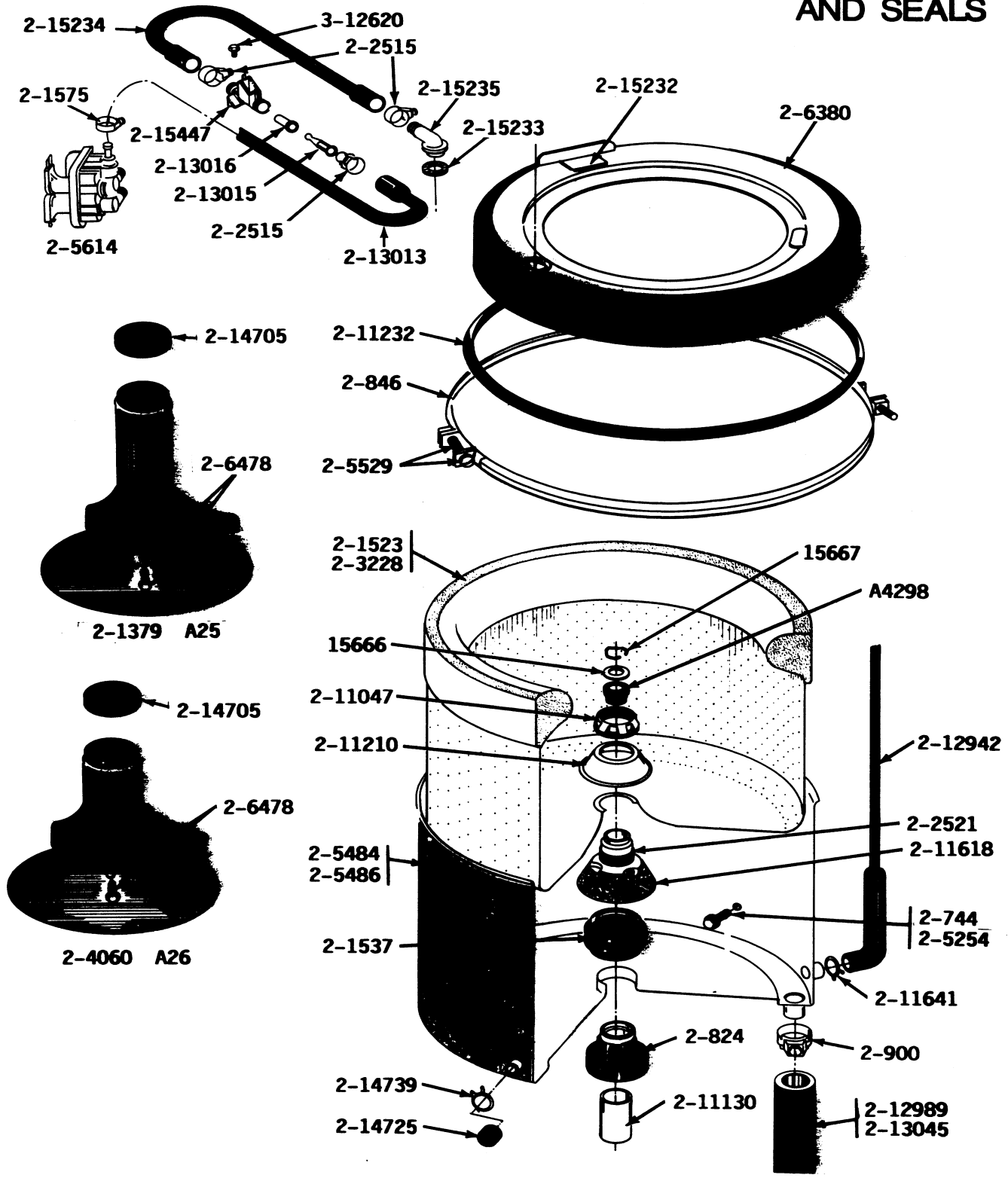

MA70B11

## Section: TUB, AGITATOR, MOUNTING STEM & SEAL

No.	Part No.	Description	Series	Qty
1	0A4298	SEAL, AGITATOR DRIVE SHAFT	00	1
2	015666	WASHER,RETAINING(CENTER SEAL)-	00	1
3	015667	RETAINING RING	00	1
4	200744	BOLT & GASKET ASSY.(SHORT)	00	1
5	200824	BEARING, TUB	00	1
6	200846	CLAMP - TUB COVER	00	1
7	200900	CLAMP, SPRAY ARM HOSE	00	1
8	201379	AGITATOR - BLACK	00	1
9	N 201523	INNER TUB	00	1
10	201537	SEAL AND SPRING	00	1
11	201575	HOSE CLAMP	00	1
12	202515	HOSE CLAMP - 1-1/16 INCH	00	1
13	202521	MOUNTING STEM	00	1
15	204012	MOUNTING STEM REPAIR KIT	00	1
16	204013	TUB BEARING REPAIR KIT	00	1
18	205254	BOLT & GASKET ASSEMBLY (LONG)	00	1
19	205484	OUTER TUB Note: PART NOT USED	00	1
20	205486	TUB, OUTER	00	1
21	205529	NUT & BOLT KIT FOR TUB CLAM	00	1
22	205614	WATER VALVE 120V 60HZ	00	1
23	206380	TUB COVER	00	1
24	206478	SCREW & WASHER FOR AGITATOR	00	1
25	206683	INJECTOR HOSE KIT	00	1
26	211047	NUT, CLAMPING (INNER TUB)	00	1
27	211100	WASHER, CUSHION	00	1
28	211130	LINER, TUB BEARING	00	1
29	211210	WASHER,CLAMPING NUT(STAINLESS)	00	1
30	211232	SEAL	00	1
31	211618	SET SCREW, MTG. STEM	00	1
32	211641	CLAMP, 1-1/16"	00	1
33	212942	AIR DOME AND TUBE	00	1
34	212989	HOSE, OUTER TUB TO PUMP	00	1
35	213013	HOSE, INJECTOR	00	1
36	213015	INJECTOR NOZZLE	00	1
37	213016	VALVE FOR INJECTOR SUB	00	1
38	213045	DRAIN HOSE-TUB TO PUMP Note: PART NOT USED	00	1
39	214705	AGITATOR CAP	00	1
40	214725	CAP FOR SPOUT-OUTER TUB	00	1
41	214739	SPRING HOSE CLAMP	00	1
42	215232	UNBALANCE BUMPER	00	1
43	215233	SEAL FOR INJECTOR TUBE	00	1
44	215234	INJECTOR FILL HOSE	00	1
45	215235	INJECTOR TUBE	00	1
46	215447	SLEEVE FOR INJECTOR	00	1
47	312620	SEMS SCREW, #10-16 X 1/2"	00	1

\*Color Code (-)=Not Shown #=Series, Serial Prefix or Run No., N=Not Available

Section: TRANSMISSION (SERIES 00)

Model: GA25CS

**ALL MODELS**

**TRANSMISSION**

PRIOR TO SERIES 10

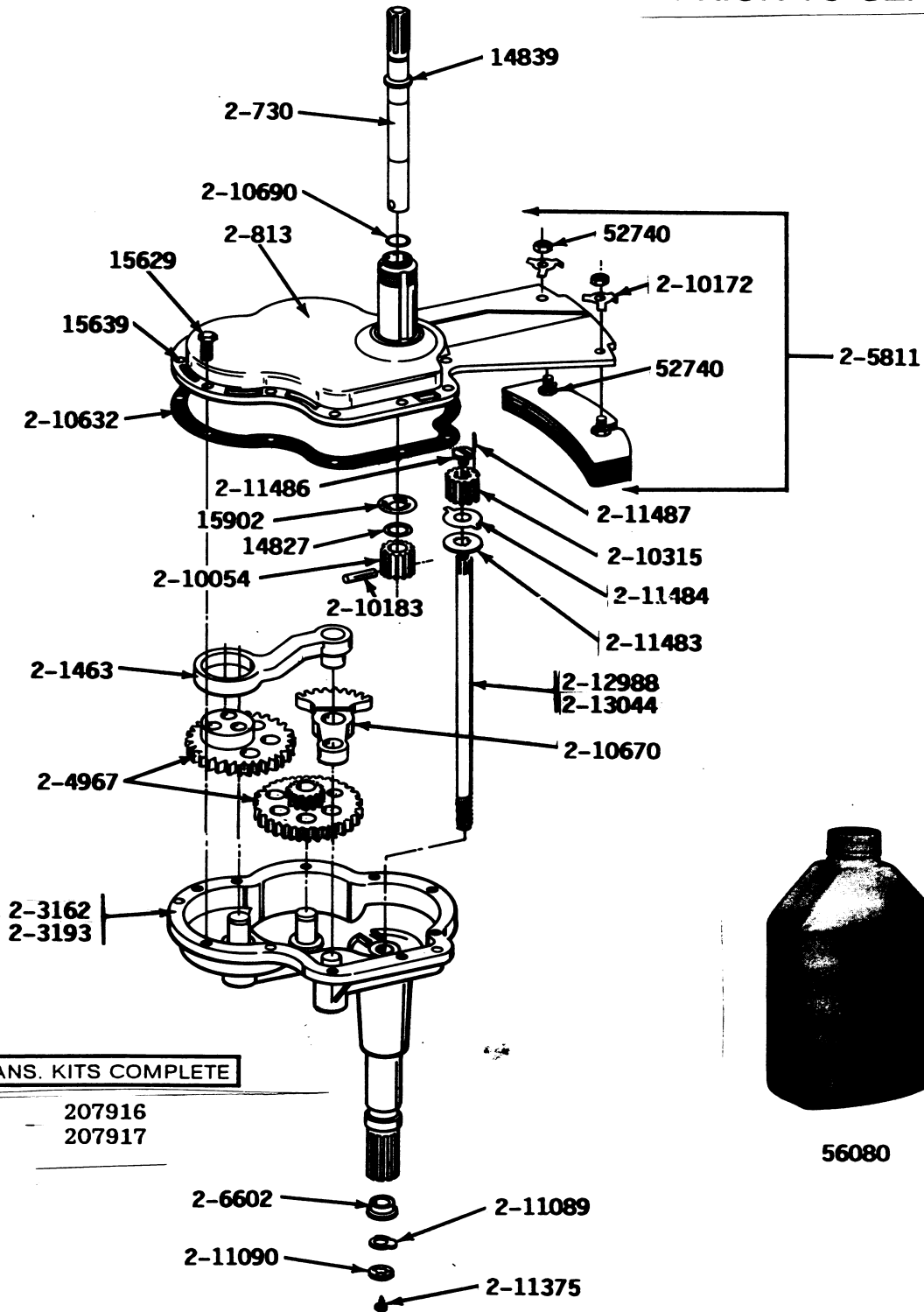

TRANS. KITS COMPLETE

207916  
207917

MA70B13

## Section: TRANSMISSION (SERIES 00)

No.	Part No.	Description	Series	Qty
1	014827	WASHER-CENTER SHAFT	00	1
2	014839	COLLAR-DRIVE SHAFT	00	1
3	015629	BOLT, GRINDING CHAMBER-DRAI	00	1
4	N 015639	DOWEL PIN	00	1
5	015902	SPRING FOR AGITATOR	00	1
6	052740	NUT	00	1
7	056080	TRANS LUBE - AUTO, 34 OZ.	00	1
8	200730	AGITATOR SHAFT	00	1
9	N 200813	GEAR CASE COVER ASSEMBLY	00	1
10	N 201463	PITMAN WITH WRIST PIN	00	1
11	N 203162	GEAR HOUSING W/STUDS & TUBE	00	1
13	204967	GEAR KIT-POWER FIN AGITATOR	00	1
14	N 205811	COUNTERWEIGHT	00	1
15	206602	SEAL, LIP (CENTER SHAFT)	00	1
16	210054	PINION	00	1
17	N 210172	LOCK WASHER	00	1
18	210183	GROOV-PIN, 1/4 X 1-1/4	00	1
19	210315	PINION	00	1
20	210632	GASKET	00	1
21	N 210670	SEGMENT	00	1
22	210690	SEAL, RUBBER	00	1
23	211089	LUG, STOP	00	1
24	211090	WASHER, LOCK	00	1
25	211375	SCREW,STOP LUG(CENTER SHAFT)	00	1
26	211483	WASHER, SPLINED	00	1
27	211484	LUG WASHER	00	1
28	211486	SCREW, 3/8-16 X 1/2 INCH	00	1
29	N 211487	GROOV-PIN	00	1
30	212988	CENTER SHAFT	00	1

\*Color Code (-)=Not Shown #=Series, Serial Prefix or Run No., N=Not Available

Section: ORBITAL TRANSMISSION (SERIES 10)

Model: GA25CS

**ALL MODELS** **ORBITAL TRANSMISSION**

SERIES 10

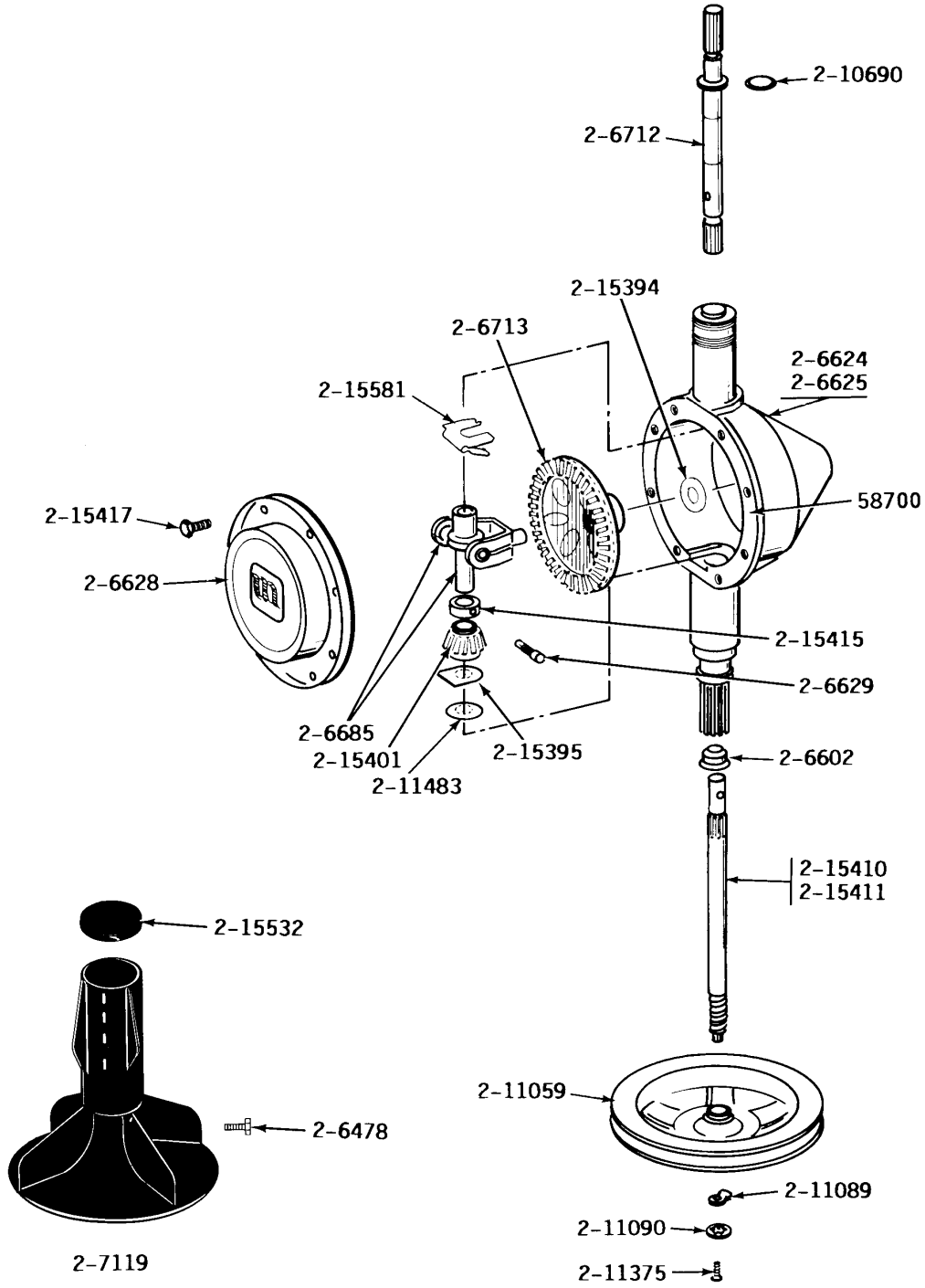



## Section: ORBITAL TRANSMISSION (SERIES 10)

No.	Part No.	Description	Series	Qty
1	058700	SILASTIC,ADH.SEALANT	10	1
2	206478	SCREW & WASHER FOR AGITATOR	10	1
3	206602	SEAL, LIP (CENTER SHAFT)	10	1
4	206624	HOUSING, TRANSMISSION	10	1
5	206625	HOUSING, TRANSMISSION	10	1
6	206628	COVER, TRANSMISSION	10	1
7	206629	PIN, COLLAR	10	1
8	206685	BLOCK, TORQUE AND YOKE ASSEMBL	10	1
9	206712	ASSEMBLY, AGITATOR SHAFT	10	1
10	206713	GEAR, BEVEL	10	1
11	207119	AGITATOR W/LOCK SCREW	10	1
12	210690	SEAL, RUBBER	10	1
13	211059	PULLEY, DRIVE	10	1
14	211089	LUG, STOP	10	1
15	211090	WASHER, LOCK	10	1
16	211375	SCREW,STOP LUG(CENTER SHAFT)	10	1
17	211483	WASHER, SPLINED	10	1
18	215394	WASHER, BEVEL GEAR	10	1
19	215395	PLATE, CLUTCH	10	1
20	215401	PINION	10	1
21	215410	CENTER SHAFT - LARGER	10	1
22 N	215411	SHAFT, CENTER	10	1
23	215415	COLLAR, LOWER	10	1
24	215417	SCREW, TRANSMISSION COVER	10	1
25	215532	AGITATOR CAP - BLACK	10	1
26	215581	SPRING, AGITATOR SHAFT	10	1

\*Color Code (-)=Not Shown #=Series, Serial Prefix or Run No., N=Not Available

Section: BASE, PUMP, MOTOR & COMPONENTS

Model: GA25CS

**ALL MODELS** BASE, PUMP, MOTOR AND COMPONENTS

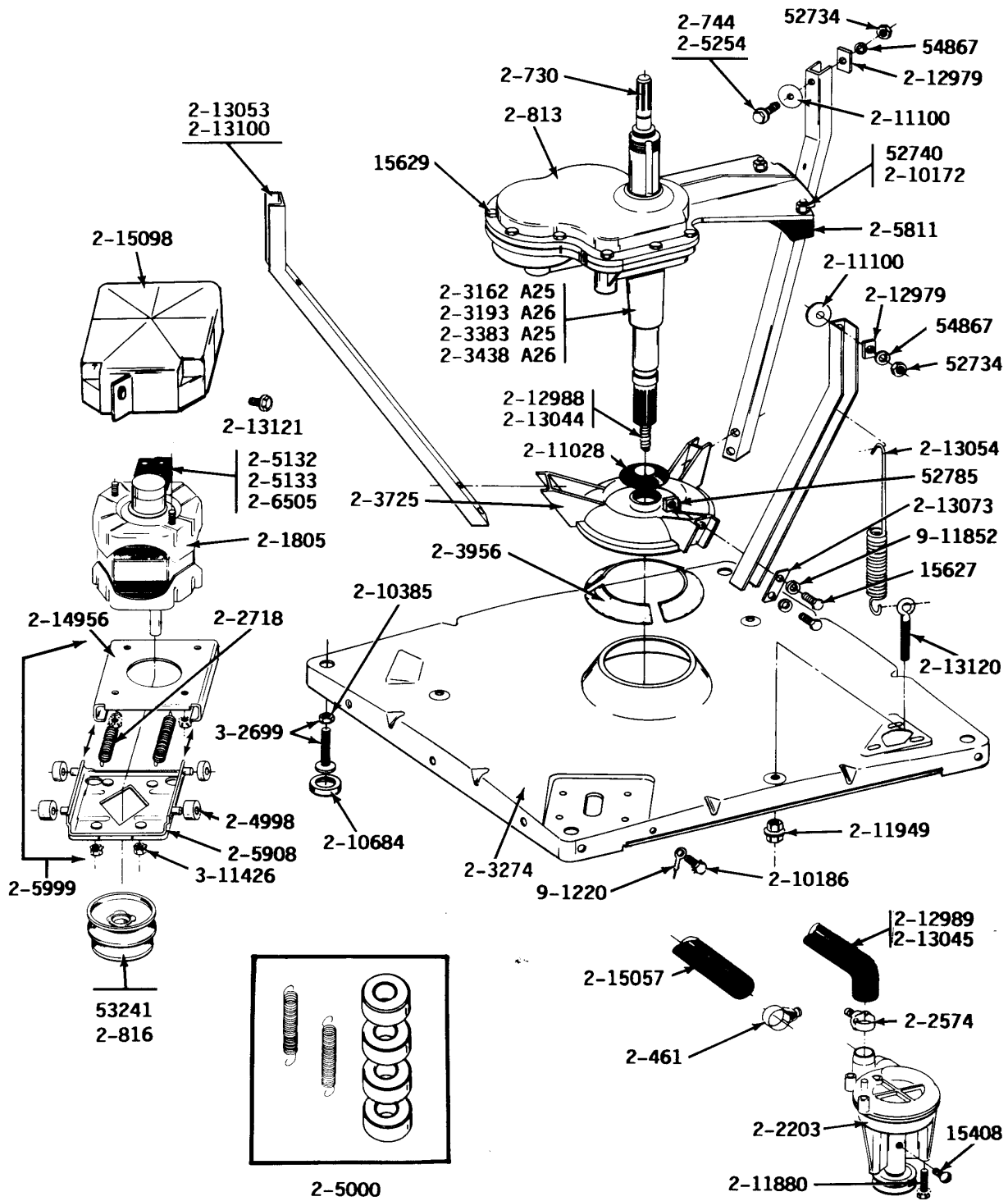

## Section: BASE, PUMP, MOTOR & COMPONENTS

No.	Part No.	Description	Series	Qty
1	015408	SCREW, BEARING INSERT	00	1
2	015627	SCREW, HEX HD CAP 5/16 X 5/8	00	1
3	015629	BOLT, GRINDING CHAMBER-DRAI	00	1
4	052734	NUT	00	1
5	052785	NUT,BRACE TO DAMPER	00	1
6	053241	SET SCREW, PULLEY	00	1
7	054867	WASHER, LOCK	00	1
8	200461	HOSE CLAMP - 1-5/8 INCH	00	1
9	200730	AGITATOR SHAFT	00	1
10	200744	BOLT & GASKET ASSY.(SHORT)	00	1
11	N 200813	GEAR CASE COVER ASSEMBLY	00	1
12	200816	PULLEY, MOTOR (W/SET SCREW)	00	1
13	201805	MOTOR (ONE SPEED)	00	1
14	202203	PUMP AS PAK	00	1
15	202574	CLAMP, HOSE	00	1
16	202718	TENSION SPRINGS	00	1
17	N 203162	GEAR HOUSING W/STUDS & TUBE	00	1
18	N 203193	GEAR HOUSING W/STUDS & TUBE	00	1
19	203274	BASE WITH DAMPER PADS	00	1
20	203383	TRANS & CENTER ASSM. REG TU	00	1
22	203725	DAMPER W/BOLT & CLIP	00	1
23	203956	DAMPER PAD KIT (W/POLY LUBE)	00	1
24	204998	GLIDE KIT (4 W/POLY LUBE)	00	1
25	205000	GLIDE & SPRING KIT	00	1
26	205132	SWITCH, MOTOR START Note: SWITCH, MOTOR START PROD. NO. 2-1664-4, 2-1664-9, 2-1664-10 2-1664-12 AND 2-5463-2	00	1
27	N 205133	MOTOR EXTERNAL START SWITCH Note: SWITCH, MOTOR START PROD. NO. 2-1664-8 AND 2- 5463	00	1
28	205254	BOLT & GASKET ASSEMBLY (LONG)	00	1
29	N 205811	COUNTERWEIGHT	00	1
30	205908	LOWER MOTOR MOUNT	00	1
31	205999	MOTOR MOUNT ASSM COMPLETE	00	1
32	206505	SWITCH, MOTOR START Note: SWITCH, MOTOR START PROD. NO. 2-1664-11 AND 2-5463-1	00	1
33	N 210172	LOCK WASHER	00	1
34	210186	SCREW, GROUND WIRE TO BASE--NA	00	1
35	210385	NUT, LOCK	00	1
36	210684	FOOT, RUBBER	00	1
37	211028	DEFLECTOR,WATER (DRIVE TUBE)	00	1
38	211100	WASHER, CUSHION	00	1
39	211880	SCREW, HEX HD #10 X 1/2 INC	00	1
40	211949	NUT, EYEBOLT	00	1
41	212979	WASHER, TUB BRACE	00	1
42	212988	CENTER SHAFT	00	1
43	212989	HOSE, OUTER TUB TO PUMP	00	1
47	213054	CENTERING SPRING - 3 USED	00	1
48	213073	WASHER, DOUBLE	00	1
49	213100	BRACE, TUB	00	1
50	213120	EYE BOLT FOR CENTER SPRING	00	1
51	213121	SCREW	00	1
52	214956	MOUNT, MOTOR/UPPER	00	1
53	215057	DRAIN HOSE	00	1
54	215098	SHIELD, MOTOR	00	1
55	302699	LEG, ADJUSTABLE (W/NUT)	00	1
56	311426	NUT, WASHERED LOCK	00	1
57	901220	WIRE, GROUND	00	1
58	911852	WASHER, LOCK (BRACE)	00	1

\*Color Code (-)=Not Shown #=Series, Serial Prefix or Run No., N=Not Available

Section: CLUTCH, BRAKE & BELTS

Model: GA25CS

**ALL MODELS** CLUTCH, BRAKE AND BELTS

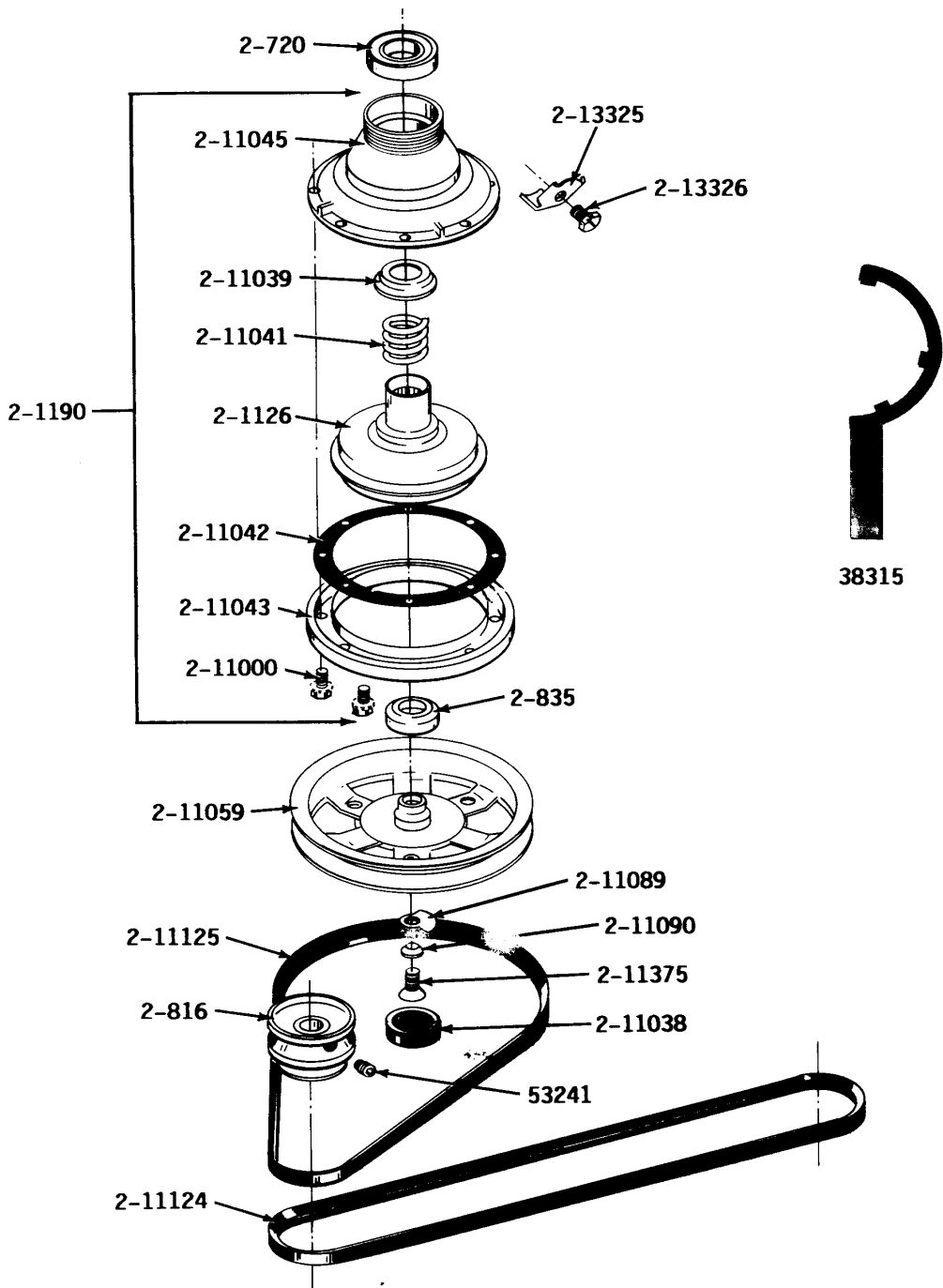

## Section: CLUTCH, BRAKE & BELTS

No.	Part No.	Description	Series	Qty
1	038315	TOOL, BRAKE PKG ASSY	00	1
2	053241	SET SCREW, PULLEY	00	1
3	200720	BALL BEARING, RADIAL	00	1
4	200816	PULLEY, MOTOR (W/SET SCREW)	00	1
5	200835	BEARING, BRAKE ROTOR	00	1
6	201126	ROTOR, BRAKE (W/FACING)	00	1
7	201190	BRAKE ASSEMBLY	00	1
8	211000	SCREW,HEX HEAD (BRAKE DRUM)	00	1
9	N 211038	CAP, OIL RETAINER	00	1
10	211039	RETAINER, BRAKE SPRING	00	1
11	211041	SPRING, BRAKE	00	1
12	211042	GASKET, BRAKE DRUM	00	1
13	211043	DRUM, BRAKE	00	1
14	211045	HOUSING, BRAKE	00	1
15	211059	PULLEY, DRIVE	00	1
16	211089	LUG, STOP	00	1
17	211090	WASHER, LOCK	00	1
18	211124	V BELT, PUMP	00	1
19	211125	V BELT,DRIVE PULLEY	00	1
20	211375	SCREW,STOP LUG(CENTER SHAFT)	00	1
21	213325	CLIP, RETAINER	00	1
22	213326	SCREW, RETAINING CLIP	00	1

\*Color Code (-)=Not Shown #=Series, Serial Prefix or Run No., N=Not Available