

# MAYTAG GA283 Owner's Manual

[Shop genuine replacement parts for MAYTAG GA283](#)

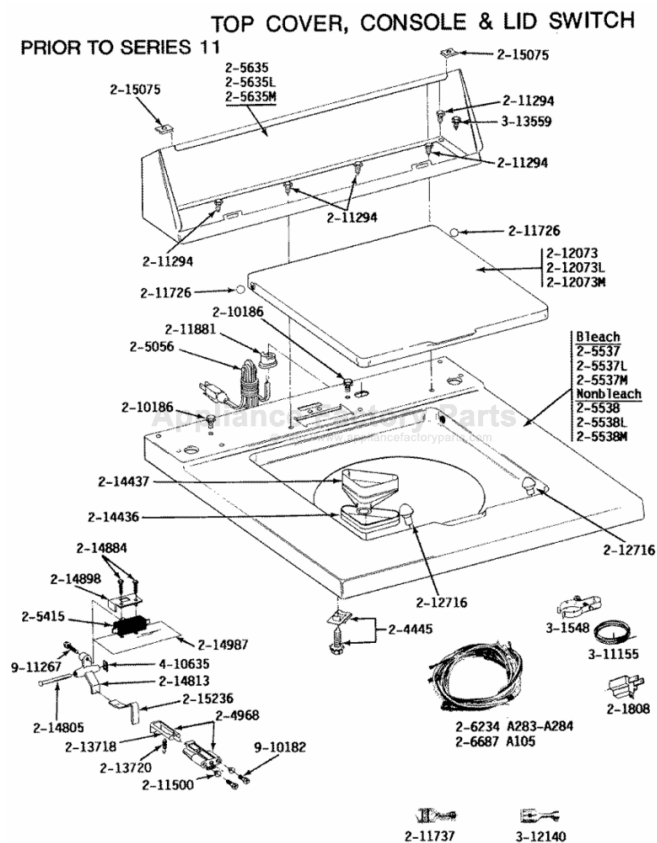

[Find Your MAYTAG Washer Parts - Select From 1759 Models](#)

----- Manual continues below part list -----

## Available Replacement Parts for MAYTAG GA283

<a href="#">214765</a>	GASKET AFTERMARKET
<a href="#">211100</a>	NLA 08/18 AUTO FIBERWASHR
<a href="#">211047</a>	USE WP6-2110472 NUT- CLAMP AW
<a href="#">210684</a>	USE WP210684 PAD DR
<a href="#">210315</a>	NLA 3/14 PINION
<a href="#">203956</a>	KIT-DAMPER DR
<a href="#">WP211232</a>	SEAL DR
<a href="#">6-2095720</a>	MOUNTING S AW AFTERMARKET
<a href="#">WP211726</a>	BALL DR
<a href="#">WP6-2008160</a>	PULLEY-MOTOR **new**
<a href="#">525</a>	FILL VALVE CW151

# WASHER

## Repair Parts List

MODEL NUMBER

GA283

When requesting service or ordering parts, always provide the following information:

- Product Type
- Part Number
- Model Number
- Part Description

**MAYTAG**®

©2005 Maytag Services

Section: TOP COVER, CONSOLE & LID SWITCH

Model: GA283

**MODELS A105-A283-A284**

**TOP COVER, CONSOLE & LID SWITCH**

PRIOR TO SERIES 11

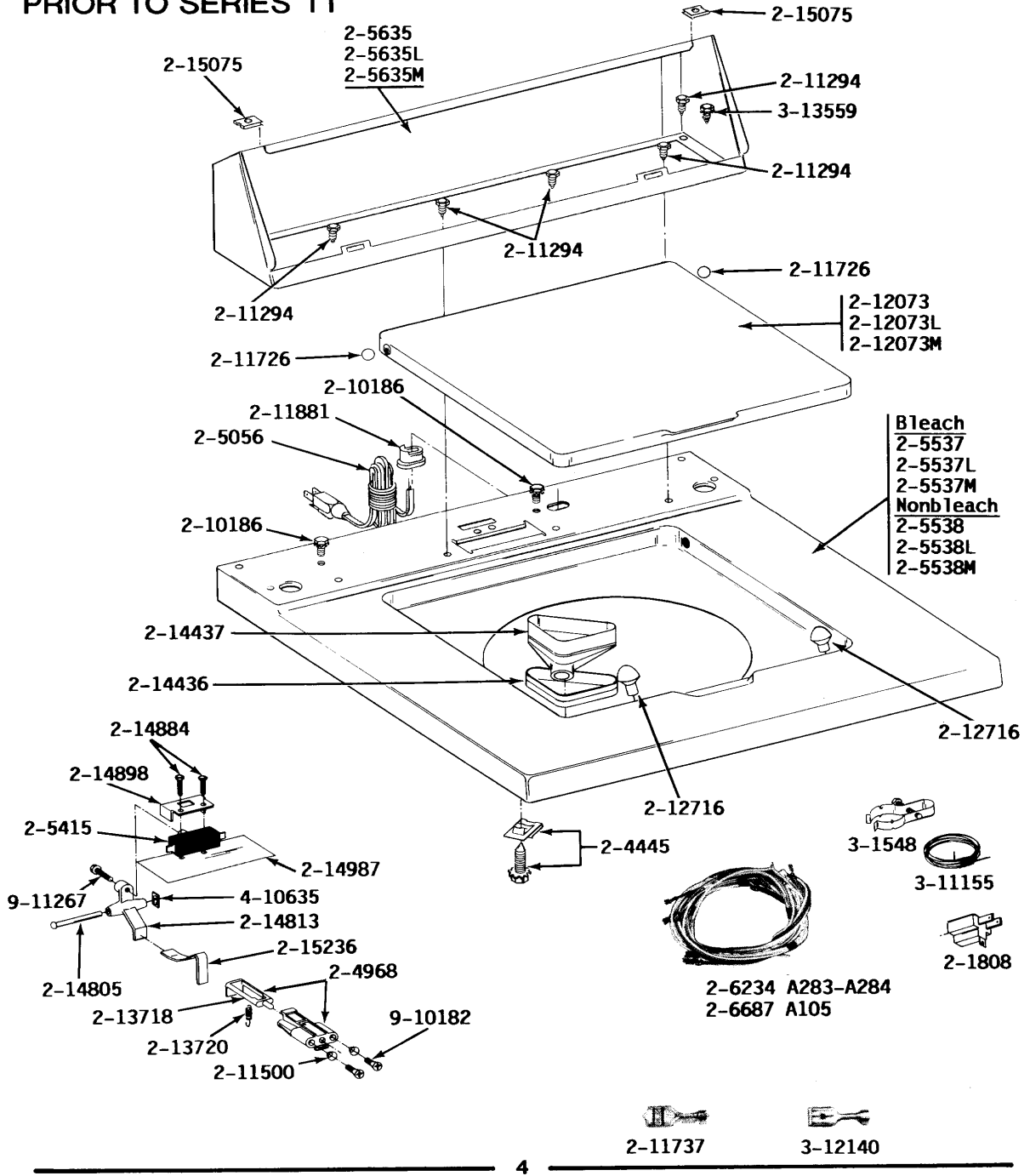

MA67A5

## Section: TOP COVER, CONSOLE & LID SWITCH

No.	Part No.	Description	Series	Qty
1	N 201808	CONVERTER	00	1
2	204445	SCREW & FASTENER ASY. Note: SCREW & FASTENER ASSEMBLY	00	1
3	204968	PLUNGER & BRACKET ASSEMBLY	00	1
4	205056	CORD, POWER	00	1
5	205415	SWITCH, LID (W/O TUB LIGHT)	00	1
8	N 205538M	TOP COVER-HARVEST WHEAT Note: (HVST WHEAT)	00	1
11	N 205635M	CONSOLE (HVST WHEAT) Note: (HVST WHEAT)	00	1
12	N 206234	WIRE HARNESS Note: HARNESS, WIRE	00	1
13	210186	SCREW, GROUND WIRE TO BASE--NA	00	2
14	211294	SCREW Note: SCREW, CONSOLE	00	5
15	211500	WASHER,BRACKE TO TOP COVER Note: WASHER, BRACKET	00	2
16	211726	HINGE, BALL	00	2
17	211737	WIRE CONNECTOR Note: CONNECTOR, WIRE	00	1
18	211881	GROMMET, CORD	00	1
36	N 212073M	LID-HARVEST WHEAT Note: (HVST WHEAT)	00	1
37	212716	BUMPER, LID	00	2
38	213718	LID SWITCH PLUNGER Note: PLUNGER, LID SWITCH	00	1
39	213720	SPRING Note: SPRING, UNBALANCE LEVER	00	1
40	214805	PIN FOR UNBALANCE LEVER Note: PIN, UNBALANCE LEVER	00	1
41	214813	LEVER FOR LID SWITCH Note: LEVER, LID SWITCH	00	1
42	214884	SCREW - LID SWITCH Note: SCREW, LID SWITCH	00	2
43	214898	COVER FOR LID SWITCH Note: COVER, LID SWITCH	00	1
43	215075	FASTENER,CNTRL PNL TO CONSOLE Note: FASTENER, CONTROL PANEL	00	2
44	215236	UNBALANCE LEVER Note: LEVER, UNBALANCE	00	1
44	214987	MOISTURE BARRIER FOR SWITCH Note: MOISTURE BARRIER, SWITCH	00	1
45	301548	CLAMP, GROUND (W/SCREW)	00	1
46	311155	GROUND WIRE Note: WIRE, GROUND	00	1
47	312140	WIRE CONNECTOR Note: CONNECTOR, WIRE	00	1
48	313559	SCREW Note: SCREW, CONSOLE	00	1
49	410635	FASTENER Note: FASTENER, LID SWITCH	00	1
50	910182	SCREW Note: SCREW, BRACKET	00	2
51	911267	SCREW, PUMP COVER	00	1

\*Color Code (-)=Not Shown #=Series, Serial Prefix or Run No., N=Not Available

Section: CABINET, WATER VALVE, HOSES & FRNT PANEL

Model: GA283

**MODELS A105-A283-A284**

**CABINET, WATER VALVE, HOSES & FRONT PANEL**

ACCESSORY HOSES

- 2-5828 4 ft. Straight Ends
- 2-672 5 ft. 90° Elbow
- 2-688 6 ft. 90° Elbow
- 2-681 10 ft. 90° Elbow
- 2-2861 Box of (25) 5 ft. straight end hoses,  
(25) gaskets, (25) screens

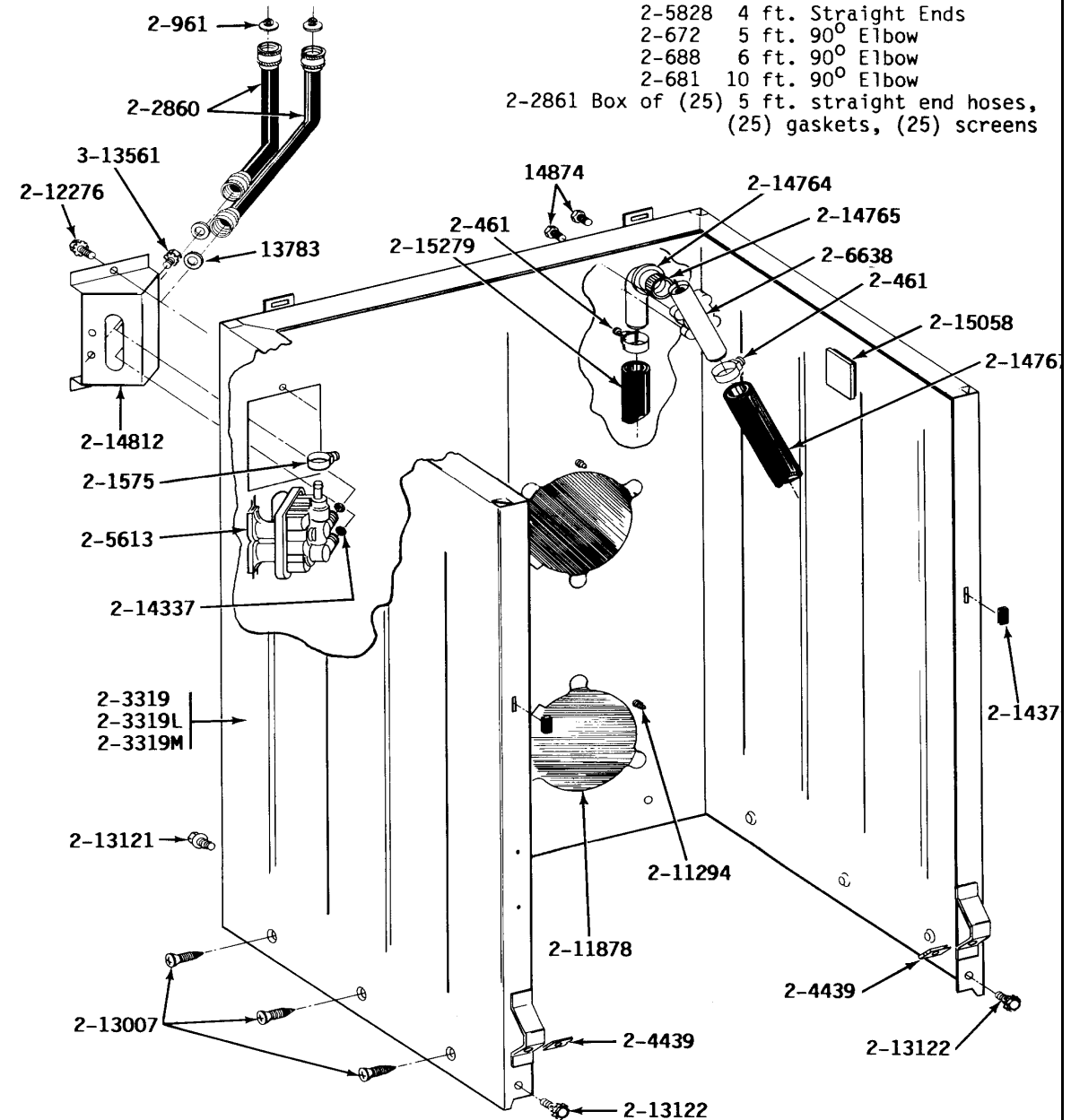

**Section: CABINET, WATER VALVE, HOSES & FRNT P**

No.	Part No.	Description	Series	Qty
1	Y013783	GASKET, INLET HOSE	00	1
2	Y014874	SCREW	00	4
3	200461	HOSE CLAMP - 1-5/8 INCH Note: CLAMP HOSE (1-5/8 INCH)	00	1
4	200672	INLET HOSE ASSY. Note: INLET HOSE ASSEMBLY	00	1
5	200681	INLET HOSE, HOT 10 FT. Note: HOSE, INLET (HOT 10 FT)	00	1
6	200688	INLET HOSE, HOT 6 FT. Note: HOSE, INLET (HOT 6 FT)	00	1
7	200832	CAPACITOR	00	1
8	200961	SCREEN WASHER, INLET HOSE	00	1
9	201575	HOSE CLAMP Note: CLAMP, HOSE	00	1
10	202860	INLET HOSE ASSY. Note: INLET HOSE ASSEMBLY	00	1
11	202861	CARTON OF 25 HOSE, 5'	00	1
12	203237	#17 WIRE WITH TERMINAL Note: WIRE, #17 WITH TERMINAL	00	1
15 N	203319M	CABINET-HARVEST WHEAT Note: (HVST WHEAT)	00	1
16	204439	SCREW & FSTNER ASSY(FRT.PANEL)	00	1
17	205613	WATER VALVE Note: VALVE, WATER	00	1
18	205828	HOSE, INLET ASSY. Note: HOSE, INLET ASSEMBLY	00	1
19	206103	CAPACITOR KIT	00	1
20	206638	SIPHON BREAK(W/CLAMP)	00	1
21	211149	CLIP, CAPACITOR	00	1
22	211294	SCREW Note: SCREW, ACCESS PLATE	00	5
23 N	211878	PLATE, ACCESS	00	2
24	212276	SCREW Note: SCREW, BRACKET	00	1
25	212982	FASTENER, PANEL	00	1
28 N	212998M	FRONT PANEL-HARVEST WHEAT Note: (HVST WHEAT)	00	1
29	213007	SCREW, CABINET	00	6
30	213121	SCREW Note: SCREW, CABINET BASE	00	3
31	213122	SCREW,CBNT.TO FRNT OF BASE--NA Note: SCREW,CABINET BASE FRONT	00	2
32	213846	GUARD, BELT	00	1
33	214337	SCREEN, VALVE	00	1
34	214376	SPACER, FRONT PANEL	00	1
35	214764	SIPHON BREAK ELBOW Note: ELBOW, SIPHON BREAK	00	1
36	214765	GASKET, SIPHON BREAK	00	1
37	214767	HOSE,PUMP TO SIPHON BREAK	00	1
38	214812	BRACKET,WATER VALVE	00	1
39	215058	PAD, CABINET BUMPER	00	1
40	215279	HOSE, DRAIN	00	1
41 N	313561	SCREW----NA Note: SCREW, BRACKET	00	2

\*Color Code (-)=Not Shown #=Series, Serial Prefix or Run No., N=Not Available

Section: TUB, AGITATOR, MOUNTING STEM & SEAL

Model: GA283

**MODELS A105-A283-A284**

**TUB, AGITATOR, MOUNTING STEM & SEALS**

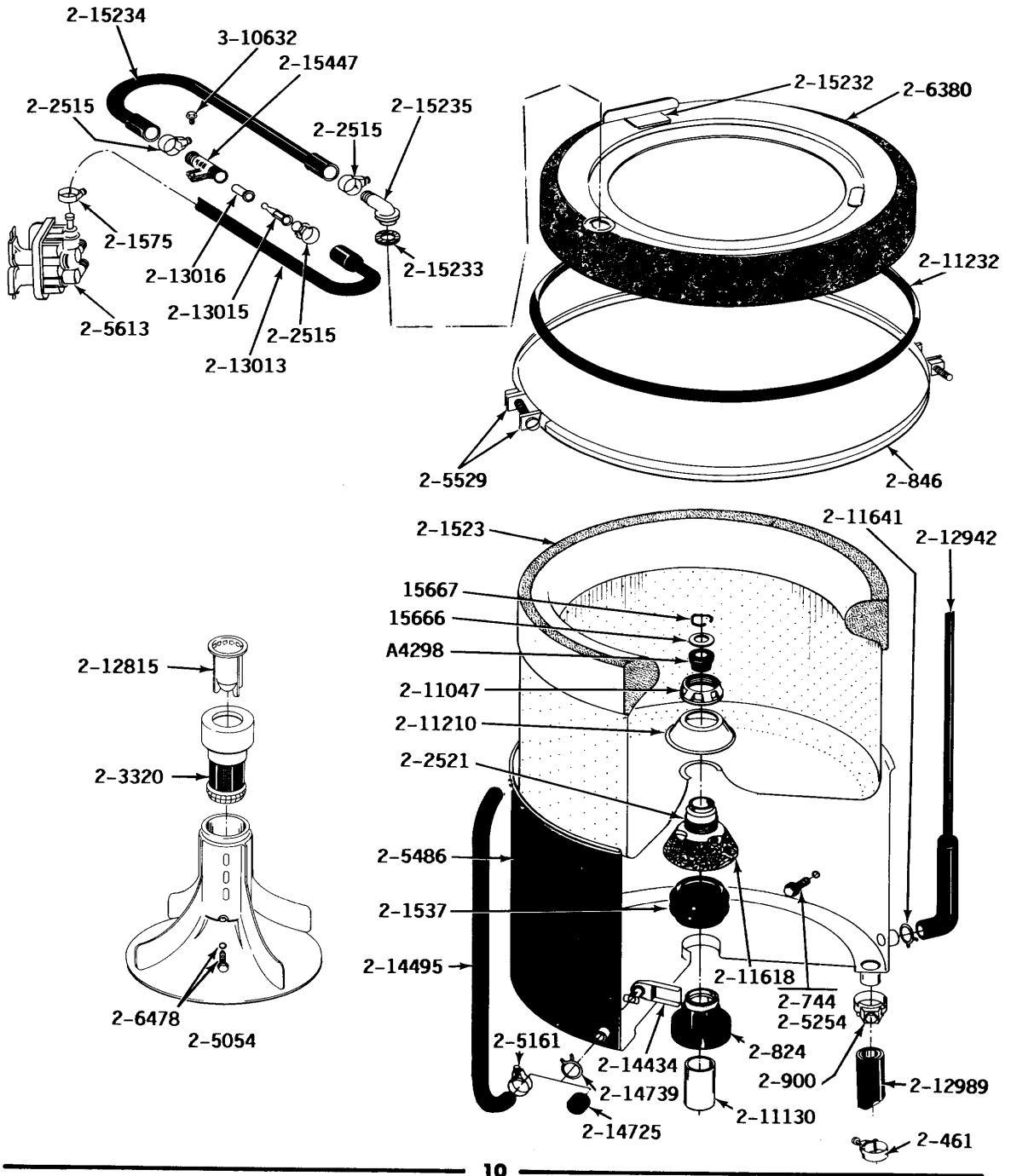

MA67A11

## Section: TUB, AGITATOR, MOUNTING STEM & SEAL

No.	Part No.	Description	Series	Qty
1	Y0A4298	SEAL, AGITATOR DRIVE SHAFT	00	1
2	015666	WASHER,RETAINING(CENTER SEAL)-	00	1
3	Y015667	RETAINING RING	00	1
4	Y054867	WASHER, LOCK	00	1
5	200461	HOSE CLAMP - 1-5/8 INCH Note: CLAMP, HOSE (1-5/8 INCH)	00	1
6	200744	BOLT & GASKET ASSY.(SHORT)	00	1
7	200824	BEARING, TUB	00	1
8	200846	CLAMP - TUB COVER Note: CLAMP, TUB COVER	00	1
9	200900	CLAMP, SPRAY ARM HOSE	00	1
10	N 201523	INNER TUB Note: TUB, INNER	00	1
11	201537	SEAL AND SPRING Note: SEAL & SPRING	00	1
12	201575	HOSE CLAMP Note: CLAMP, HOSE	00	1
13	202515	HOSE CLAMP - 1-1/16 INCH Note: CLAMP, HOSE (1-1/16 INCH)	00	1
14	202521	MOUNTING STEM Note: STEM, MOUNTING	00	1
15	203320	LINT FILTER - DISPENSER Note: FILTER, LINT	00	1
16	204012	MOUNTING STEM REPAIR KIT	00	1
17	204013	TUB BEARING REPAIR KIT	00	1
18	205054	AGITATOR	00	1
19	205161	CLAMP - 15/16" Note: CLAMP, BLEACH HOSE	00	1
20	205254	BOLT & GASKET ASSEMBLY (LONG)	00	1
21	205486	TUB, OUTER	00	1
22	205529	NUT & BOLT KIT FOR TUB CLAM	00	1
23	205613	WATER VALVE Note: VALVE, WATER	00	1
24	206380	TUB COVER Note: COVER, TUB	00	1
25	206478	SCREW & WASHER FOR AGITATOR Note: SCREW & WASHER, AGITATOR	00	1
27	211047	NUT, CLAMPING (INNER TUB)	00	1
28	211100	WASHER, CUSHION	00	1
29	211130	LINER, TUB BEARING	00	1
30	211210	WASHER,CLAMPING NUT(STAINLESS)	00	1
31	211232	SEAL	00	1
32	211618	SET SCREW, MTG. STEM	00	1
33	211641	CLAMP, 1-1/16"	00	1
34	212815	DISPENSER CUP Note: CUP, DISPENSER	00	1
35	212942	AIR DOME AND TUBE	00	1
36	Y212989	HOSE, OUTER TUB TO PUMP	00	1
37	213013	HOSE, INJECTOR Note: HOSE, INJECTOR	00	1
38	213015	INJECTOR NOZZLE Note: NOZZLE, INJECTOR	00	1
39	213016	VALVE FOR INJECTOR SUB Note: VALVE, INJECTOR	00	1
42	214725	CAP FOR SPOUT-OUTER TUB	00	1
43	214739	SPRING HOSE CLAMP Note: CLAMP, SPRING HOSE	00	1
44	215232	UNBALANCE BUMPER Note: BUMPER, UNBALANCE	00	1
45	215233	SEAL FOR INJECTOR TUBE Note: SEAL, INJECTOR TUBE	00	1
46	215234	INJECTOR FILL HOSE Note: HOSE, INJECTOR FILL	00	1
47	215235	INJECTOR TUBE Note: TUBE, INJECTOR	00	1
48	215447	SLEEVE FOR INJECTOR Note: SLEEVE, INJECTOR	00	1
49	310632	SCREW Note: SCREW, INJECTOR SLEEVE	00	1

\*Color Code (-)=Not Shown #=Series, Serial Prefix or Run No., N=Not Available

Section: TRANSMISSION

Model: GA283

**MODELS A105-A283-A284**

**TRANSMISSION**

PRIOR TO SERIES 10

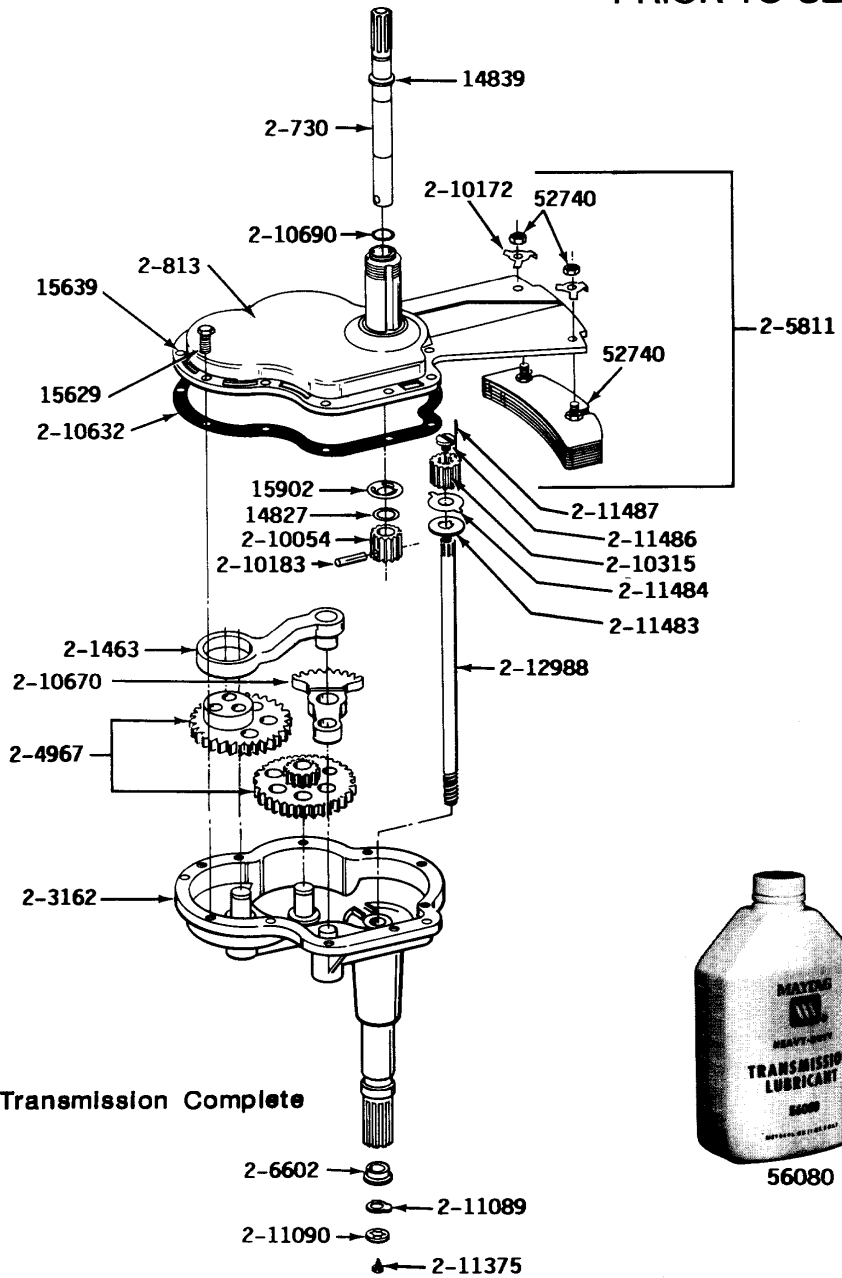

\* 2-3383 Transmission Complete

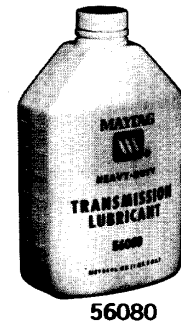

\*Transmission Complete-Includes Orb. Trans., Lint Filter, Agitator W/Lock Screw, Dispensing Cup & Instructions

## Section: TRANSMISSION

No.	Part No.	Description	Series	Qty
1	Y014827	WASHER-CENTER SHAFT Note: WASHER, CENTER SHAFT	00	1
2	014839	COLLAR-DRIVE SHAFT Note: COLLAR, DRIVE SHAFT	00	1
3	Y015629	BOLT, GRINDING CHAMBER-DRAI	00	1
4	Y015629	BOLT, GRINDING CHAMBER-DRAI	00	10
5	N 015639	DOWEL PIN Note: PIN, DOWEL	00	1
6	Y015902	SPRING FOR AGITATOR Note: SPRING, AGITATOR	00	1
7	Y052740	NUT Note: NUT, COUNTERWEIGHT	00	1
8	056080	TRANS LUBE - AUTO, 34 OZ.	00	1
9	200730	AGITATOR SHAFT Note: SHAFT, AGITATOR	00	1
10	N 200813	GEAR CASE COVER ASSEMBLY	00	1
11	N 201463	PITMAN WITH WRIST PIN Note: GEAR, PITMAN (W/ PIN)	00	1
12	N 203162	GEAR HOUSING W/STUDS & TUBE Note: HOUSING, GEAR W/STUDS & TUBE	00	1
13	203383	TRANS & CENTER ASSM. REG TU Note: TRANSMISSION ASSEMBLY	00	1
14	204967	GEAR KIT-POWER FIN AGITATOR Note: GEAR KIT, POWER FIN AGITATOR	00	1
15	N 205811	COUNTERWEIGHT	00	1
16	206602	SEAL, LIP (CENTER SHAFT)	00	1
17	210054	PINION	00	1
18	N 210172	LOCK WASHER Note: WASHER, LOCK	00	1
19	210183	GROOV-PIN, 1/4 X 1-1/4	00	1
20	210286	SEAL	00	1
21	210315	PINION Note: PINION, CENTER SHAFT	00	1
22	210632	GASKET Note: GASKET, COVER	00	1
23	N 210670	SEGMENT Note: SEGMENT, GEAR	00	1
24	210690	SEAL, RUBBER	00	1
25	211089	LUG, STOP	00	1
26	211090	WASHER, LOCK	00	1
27	211375	SCREW,STOP LUG(CENTER SHAFT)	00	1
28	211483	WASHER, SPLINED	00	1
29	211484	LUG WASHER	00	1
30	211486	SCREW, 3/8-16 X 1/2 INCH	00	1
31	N 211487	GROOV-PIN	00	1
32	212988	CENTER SHAFT Note: SHAFT, CENTER	00	1

\*Color Code (-)=Not Shown #=Series, Serial Prefix or Run No., N=Not Available

Section: ORBITAL TRANSMISSION (SERIES 10)

Model: GA283

**MODELS A105-A283-A284**

**ORBITAL TRANSMISSION**

SERIES 10

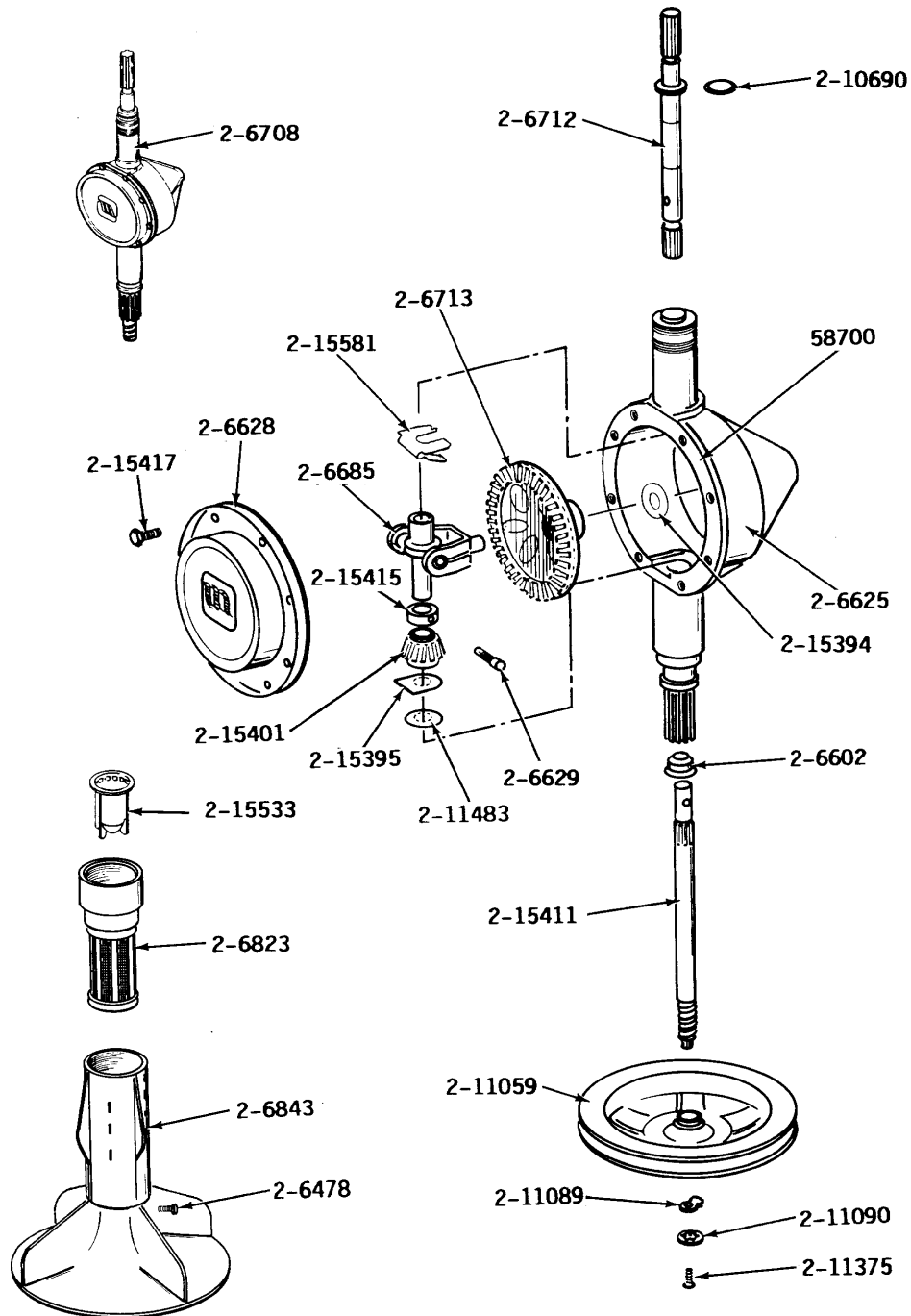

## Section: ORBITAL TRANSMISSION (SERIES 10)

No.	Part No.	Description	Series	Qty
1	Y058700	SILASTIC,ADH.SEALANT	10	1
2	206478	SCREW & WASHER FOR AGITATOR Note: SCREW & WASHER, AGITATOR	10	1
3	206602	SEAL, LIP (CENTER SHAFT)	10	1
4	206625	HOUSING, TRANSMISSION	10	1
5	206628	COVER, TRANSMISSION	10	1
6	206629	PIN, COLLAR	10	1
7	206685	BLOCK, TORQUE AND YOKE ASSEMBL Note: BLOCK & YOKE, TORQUE	10	1
8	206708	TRANSMISSION	10	1
9	206712	ASSEMBLY, AGITATOR SHAFT	10	1
10	206713	GEAR, BEVEL	10	1
11	206823	LINT FILTER - DISPENSER Note: FILTER, LINT	10	1
12	206843	AGITATOR W/LOCK SCREW/O-RIN	10	1
13	210690	SEAL, RUBBER	10	1
14	211059	PULLEY, DRIVE	10	1
15	211089	LUG, STOP	10	1
16	211090	WASHER, LOCK	10	1
17	211375	SCREW,STOP LUG(CENTER SHAFT)	10	1
18	211483	WASHER, SPLINED	10	1
19	215394	WASHER, BEVEL GEAR	10	1
20	215395	PLATE, CLUTCH	10	1
21	215401	PINION	10	1
22 N	215411	SHAFT, CENTER	10	1
23	215415	COLLAR, LOWER	10	1
24	215417	SCREW, TRANSMISSION COVER	10	8
25	215533	DISPENSER CUP Note: CUP, DISPENSER	10	1
26	215581	SPRING, AGITATOR SHAFT	10	1

\*Color Code (-)=Not Shown #=Series, Serial Prefix or Run No., N=Not Available



## Section: BASE, PUMP, MOTOR & COMPONENTS

No.	Part No.	Description	Series	Qty
1	Y015408	SCREW, BEARING INSERT	00	1
2	Y015627	SCREW, HEX HD CAP 5/16 X 5/8	00	1
3	Y015629	BOLT, GRINDING CHAMBER-DRAI	00	10
4	Y052734	NUT	00	1
5	Y052740	NUT Note: NUT, COUNTERWEIGHT	00	1
6	Y052785	NUT,BRACE TO DAMPER	00	1
7	Y053241	SET SCREW, PULLEY	00	1
8	N Y054866	LOCK WASHER	00	1
9	Y054867	WASHER, LOCK	00	1
10	200461	HOSE CLAMP - 1-5/8 INCH Note: CLAMP, HOSE (1-5/8 INCH)	00	1
11	200730	AGITATOR SHAFT Note: SHAFT, AGITATOR	00	1
12	200744	BOLT & GASKET ASSY.(SHORT)	00	1
13	N 200813	GEAR CASE COVER ASSEMBLY	00	1
14	200816	PULLEY, MOTOR (W/SET SCREW)	00	1
15	201807	MOTOR - TWO SPEED 120-60	00	1
16	202203	PUMP AS PAK	00	1
17	202574	CLAMP, HOSE	00	1
18	202718	TENSION SPRINGS Note: SPRINGS, TENSION	00	1
19	N 203162	GEAR HOUSING W/STUDS & TUBE	00	1
20	203274	BASE WITH DAMPER PADS	00	1
21	203383	TRANS & CENTER ASSM. REG TU	00	1
22	203725	DAMPER W/BOLT & CLIP	00	1
23	203956	DAMPER PAD KIT (W/POLY LUBE)	00	1
24	204807	GRND.WIRE,SUPP.PLTE TO TOP CVR Note: WIRE, GROUND MOTOR/BASE	00	1
25	204998	GLIDE KIT (4 W/POLY LUBE)	00	1
26	205000	GLIDE & SPRING KIT	00	1
27	205131	SWITCH, MOTOR START Note: PROD. #2-1666-2, #2-1666-11, #2-1666-12, #2-1666-13 & #2-5464-2	00	1
28	205132	SWITCH, MOTOR START Note: PROD. #2-1664-4, #2-1664-9 #2-1664-10, #2-1664-12 & #2-5463-2	00	1
29	N 205133	MOTOR EXTERNAL START SWITCH Note: SWITCH, MOTOR START PROD. #2-1664-8 & #2-5463	00	1
30	N 205134	MOTOR EXTERNAL START SWITCH Note: SWITCH, MOTOR START PROD. #2-1666-8	00	1
31	205254	BOLT & GASKET ASSEMBLY (LONG) Note: BOLT & GASKET ASSY.(LONG)	00	1
32	N 205811	COUNTERWEIGHT	00	1
33	205908	LOWER MOTOR MOUNT Note: MOUNT, LOWER MOTOR	00	1
34	205999	MOTOR MOUNT ASSM COMPLETE Note: MOTOR MOUNT ASSEMBLY	00	1
35	206504	MOTOR EXTERNAL START SWITCH Note: SWITCH, MOTOR START PROD. #2-1666-13 & #2-5464-1	00	1
36	206505	SWITCH, MOTOR START Note: PROD. #2-1664-11 & #2-5463-1	00	1
37	210186	SCREW, GROUND WIRE TO BASE--NA	00	1
38	N 210172	LOCK WASHER Note: WASHER, LOCK	00	1
39	210385	NUT, LOCK	00	1
40	210684	FOOT, RUBBER	00	1
41	211028	DEFLECTOR,WATER (DRIVE TUBE)	00	1
42	211100	WASHER, CUSHION	00	1
43	211880	SCREW, HEX HD #10 X 1/2 INC	00	1
44	211949	NUT, EYEBOLT	00	1
45	212979	WASHER, TUB BRACE	00	1
46	212988	CENTER SHAFT Note: SHAFT, CENTER	00	1
47	Y212989	HOSE, OUTER TUB TO PUMP	00	1
49	213073	WASHER, DOUBLE Note: WASHER, DOUBLE-BRACE/DAMPER	00	1
50	213100	BRACE, TUB	00	1
51	213120	EYE BOLT FOR CENTER SPRING Note: BOLT, CENTER SPRING	00	1
52	213121	SCREW	00	1
53	214956	MOUNT, MOTOR/UPPER	00	1
54	215098	SHIELD, MOTOR	00	1

\*Color Code (-)=Not Shown #=Series, Serial Prefix or Run No., N=Not Available

Section: BASE, PUMP, MOTOR & COMPONENTS

Model: GA283

**MODELS A105-A283-A284**

**BASE, PUMP, MOTOR & COMPONENTS**

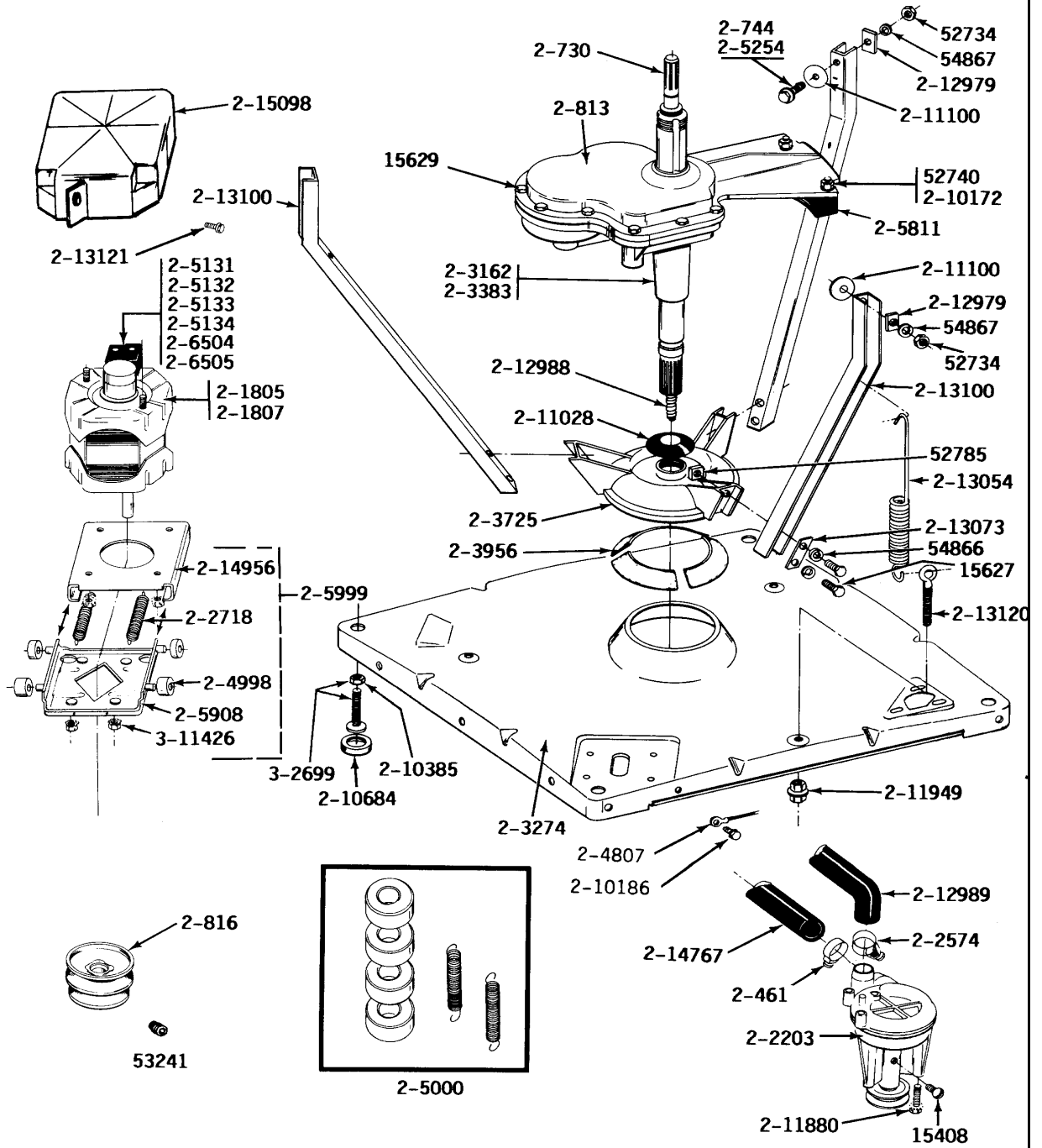

## Section: BASE, PUMP, MOTOR & COMPONENTS

No.	Part No.	Description	Series	Qty
55	214767	HOSE,PUMP TO SIPHON BREAK Note: HOSE, PUMP	00	1
56	302699	LEG, ADJUSTABLE (W/NUT)	00	1
57	311426	NUT, WASHERED LOCK Note: KEPS NUT, BASE/FRAME	00	1

\*Color Code (-)=Not Shown #=Series, Serial Prefix or Run No., N=Not Available

Section: CLUTCH, BRAKE & BELTS

Model: GA283

**MODELS A105-A283-A284 CLUTCH, BRAKE & BELTS**

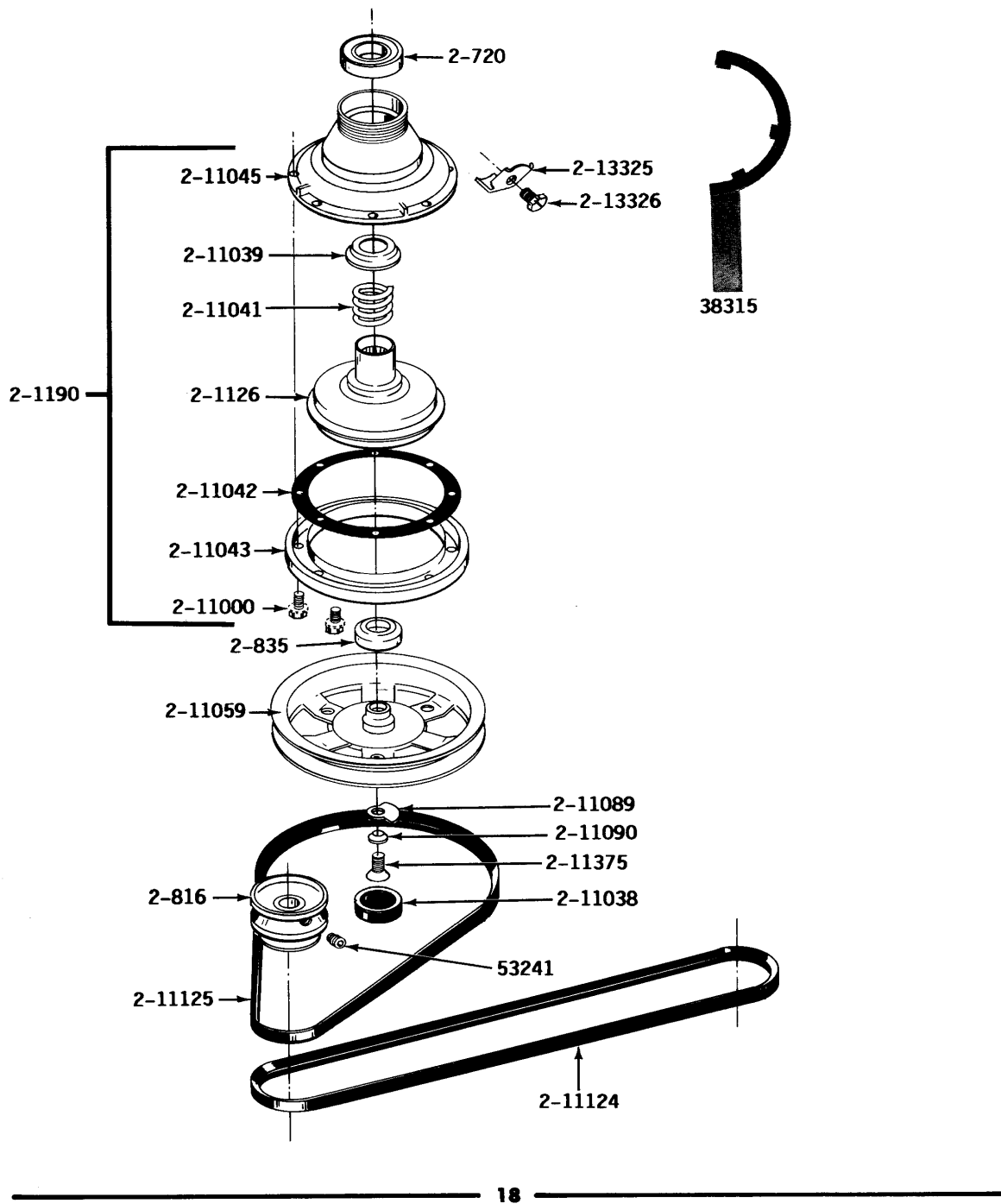

MA67B5

## Section: CLUTCH, BRAKE & BELTS

No.	Part No.	Description	Series	Qty
1	Y038315	TOOL, BRAKE PKG ASSY Note: TOOL, BRAKE	00	1
2	Y053241	SET SCREW, PULLEY	00	1
3	200720	BALL BEARING, RADIAL	00	1
4	200816	PULLEY, MOTOR (W/SET SCREW)	00	1
5	200835	BEARING, BRAKE ROTOR	00	1
6	201126	ROTOR, BRAKE (W/FACING)	00	1
7	201190	BRAKE ASSEMBLY	00	1
8	211000	SCREW,HEX HEAD (BRAKE DRUM)	00	1
9	N 211038	CAP, OIL RETAINER	00	1
10	211039	RETAINER, BRAKE SPRING	00	1
11	211041	SPRING, BRAKE	00	1
12	211042	GASKET, BRAKE DRUM	00	1
13	211043	DRUM, BRAKE	00	1
14	211045	HOUSING, BRAKE	00	1
15	211059	PULLEY, DRIVE	00	1
16	211089	LUG, STOP	00	1
17	211090	WASHER, LOCK	00	1
18	211124	V BELT, PUMP	00	1
19	211125	V BELT,DRIVE PULLEY Note: V BELT, DRIVE PULLEY	00	1
20	211375	SCREW,STOP LUG(CENTER SHAFT) Note: SCREW, DRIVE LUG	00	1
21	213325	CLIP, RETAINER Note: CLIP, DAMPER RETAINER	00	1
22	213326	SCREW, RETAINING CLIP Note: BOLT, RETAINING CLIP	00	1

\*Color Code (-)=Not Shown #=Series, Serial Prefix or Run No., N=Not Available

Section: CONTROL PANEL

Model: GA283

**MODELS A283-A284**

**CONTROL PANEL**

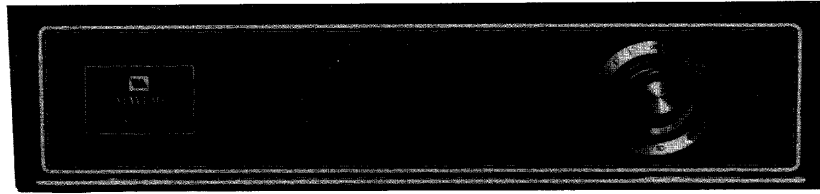

2-15211  
Use this button for the 2-6217 motor speed switch and 2-6216 water temperature switch



2-15212  
Use this button for the 2-6221 water level switch with vertical shafts



2-15213  
Use this button for the 2-6221 water level switch with horizontal shafts

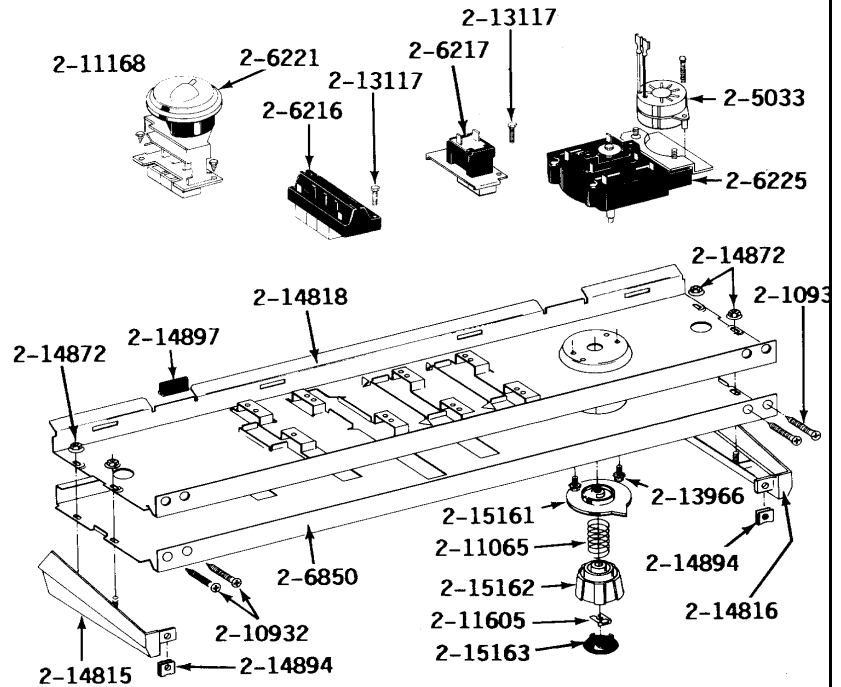

- |         |  |         |   |
|---------|--|---------|---|
| 2-5033  | Timer motor  | 2-13966 | Screw - timer to back-up plate-2 used         |
| 2-6216  | Water temperature switch   | 2-14815 | End cap for control panel -left-hand          |
| 2-6217  | Motor speed switch   | 2-14816 | End cap for control panel -right hand         |
| 2-6221  | Water level control switch   | 2-14818 | Back-up plate                                 |
| 2-6225  | Timer  | 2-14869 | Clip-back-up-not shown                        |
| 2-6850  | Control panel  | 2-14872 | Nut-end caps to back-up plate -4 used         |
| 2-10932 | Screw - control panel to console and end caps to back-up plate - 4 used            | 2-14894 | Fastener - end caps to support plate - 2 used |
| 2-11065 | Spring for timer knob  | 2-14897 | Cushion pad for control panel -2 used         |
| 2-11168 | Screw - water level control switch to back-up plate -2 used                        | 2-15161 | Timer dial indicator                          |
| 2-11605 | Retaining clip - knob to timer   | 2-15162 | Knob for timer                                |
| 2-13117 | Screw - water temperature switch and speed control switch to back-up plate -4 used | 2-15163 | Cap for timer knob                            |

## Section: CONTROL PANEL

No.	Part No.	Description	Series	Qty
1	205033	TIMER MOTOR 120-60 Note: MOTOR, TIMER 120-60	00	1
2	206216	WATER TEMPERATURE SWITCH Note: SWITCH, WATER TEMPERATURE	00	1
3	206217	SPEED CONTROL SWITCH Note: SWITCH, SPEED CONTROL	00	1
4	N 206221	WATER LEVEL SWITCH----NA Note: SWITCH, WATER LEVEL	00	1
5	206225	TIMER Note: TIMER	00	1
6	N 206850	CONTROL PANEL Note: PANEL, CONTROL	00	1
8	211065	SPRING, TIMER KNOB	00	1
10	211605	RETAINER, TIMER KNOB	00	1
12	213966	SCREW-TIMER TO CONTROL PANE Note: SCREW, TIMER	00	1
13	N 214815	END CAP F/CONTROL PANEL-LH Note: CAP, END (LT)	00	1
14	214816	END CAP F/CONTROL PANEL-RH Note: (RT)	00	1
15	214818	BACK UP PLATE Note: PLATE, BACK UP	00	1
16	N 214869	CLIP FOR BACK UP PLATE Note: CLIP, BACK UP PLATE	00	1
17	214872	PALNUT, END CAP	00	1
18	214894	FASTENER, END CAP	00	2
19	N 214897	PAD, CONTROL PANEL	00	2
20	215161	TIMER DIAL INDICATOR Note: INDICATOR, TIMER DIAL	00	1
21	215162	TIMER KNOB Note: KNOB, TIMER	00	1
22	215163	CAP FOR KNOB Note: CAP, KNOB	00	1

\*Color Code (-)=Not Shown #=Series, Serial Prefix or Run No., N=Not Available

Section: TOP COVER, CONSOLE & LID SWITCH (SER 11)

Model: GA283

**A105-A283-A284 TOP COVER, CONSOLE & LID SWITCH**

SERIES 11

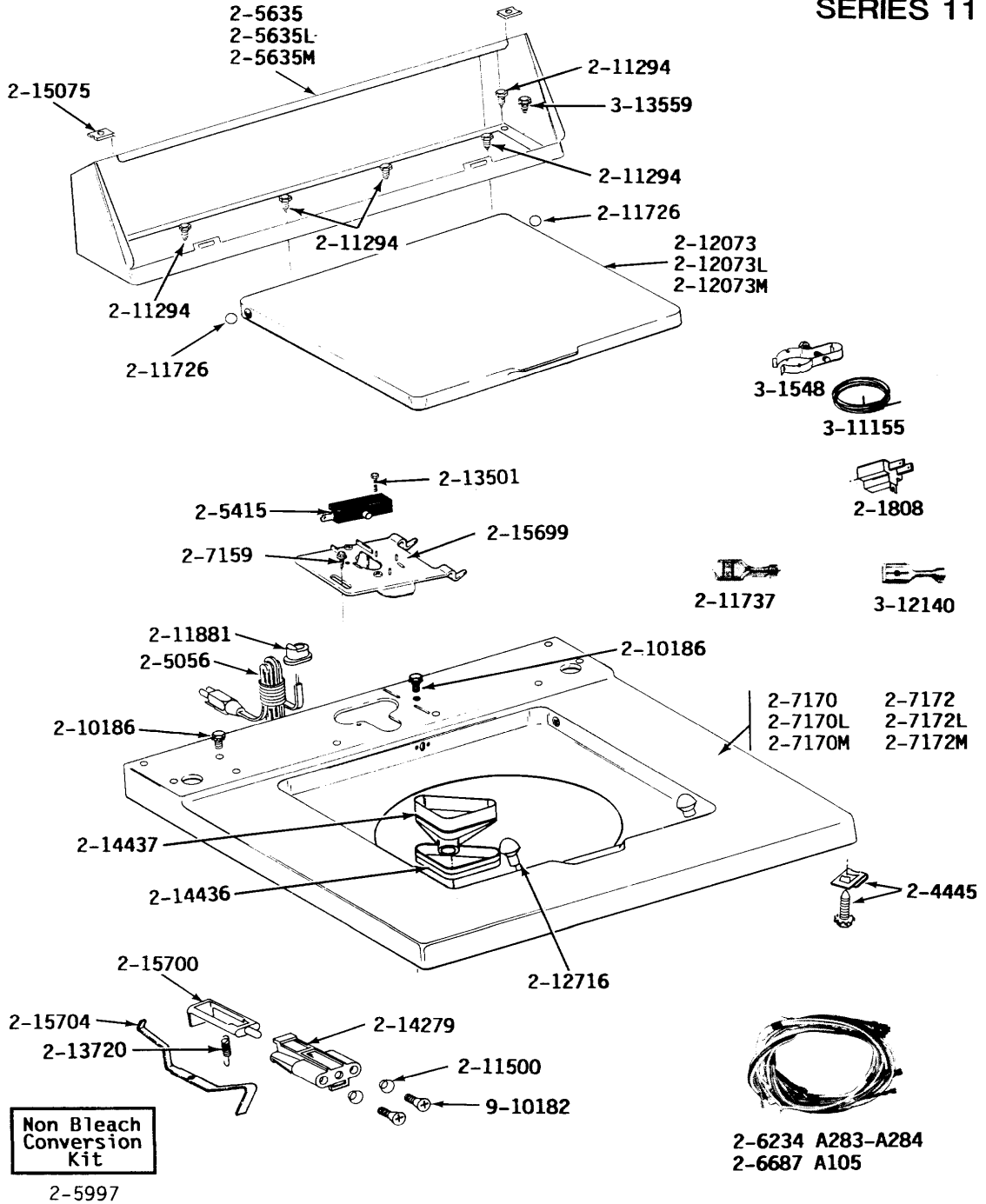

**Section: TOP COVER, CONSOLE & LID SWITCH (SER**

No.	Part No.	Description	Series	Qty
1	N 201808	CONVERTER	11	1
2	204445	SCREW & FASTENER ASY. Note: SCREW & FASTENER ASSEMBLY	11	1
3	205056	CORD, POWER	11	1
4	205415	SWITCH, LID (W/O TUB LIGHT)	11	1
7	N 205635M	CONSOLE (HVST WHEAT) Note: (HVST WHEAT)	11	1
8	205997	NON-BLEACH CONVERSION KIT	11	1
9	N 206234	WIRE HARNESS Note: HARNESS, WIRE	11	1
10	207159	SCREW Note: SCREW	11	1
13	N 207172M	TOP COVER ASSY HVT WHEAT Note: (HVST WHEAT)	11	1
14	210186	SCREW, GROUND WIRE TO BASE--NA Note: SCREW, GROUND WIRE	11	2
15	211294	SCREW Note: SCREW, CONSOLE	11	5
16	211500	WASHER,BRACKE TO TOP COVER Note: WASHER, BRACKET/TOP COVER	11	2
17	211726	HINGE, BALL	11	2
18	211737	WIRE CONNECTOR Note: CONNECTOR, WIRE	11	1
19	211881	GROMMET, CORD	11	1
23	N 212073M	LID-HARVEST WHEAT Note: (HVST WHEAT)	11	1
24	212716	BUMPER, LID	11	2
25	213501	SCREW, #6-20 X 1-1/8 INCH	11	1
26	213720	SPRING Note: SPRING, UNBALANCE LEVER	11	1
27	214279	BRACKET F/LID SWITCH PLUNGE Note: BRACKET, LID SWITCH PLUNGER	11	1
28	215075	FASTENER,CNTRL PNL TO CONSOLE Note: FASTENER, CONTROL PANEL	11	2
29	Y215699	BRACKET,SWITCH & FUSE	11	1
30	N 215700	LID SWITCH PLUNGER Note: PLUNGER, LID SWITCH	11	1
31	215704	UNBALANCE LEVER Note: LEVER, UNBALANCE	11	1
32	301548	CLAMP, GROUND (W/SCREW)	11	1
33	311155	GROUND WIRE	11	1
34	312140	WIRE CONNECTOR Note: CONNECTOR, WIRE	11	1
35	313559	SCREW Note: SCREW, GROUND CONSOLE	11	1
36	910182	SCREW Note: SCREW, BRACKET	11	2

\*Color Code (-)=Not Shown #=Series, Serial Prefix or Run No., N=Not Available