



BUILT-IN PF UNIT INSTRUCTION GUIDE

Please use this manual in conjunction with your main manual to properly assemble your built-in grill. Refer to the main manual for operating, cleaning, and maintenance instructions. The operating instructions are also located on the bottom of the side burner lid. This grill is designed for **NON-COMBUSTIBLE ENCLOSURES ONLY**, and must be installed and serviced by a qualified installer to local codes.

BUILT IN PROPANE GAS HOOK-UP: The piping up to the gas grill is the responsibility of the installer and piping should be located as shown in the built-in instructions. Do not use hose to connect the unit. It must be connected with either rigid pipe, copper tube or an approved flexible metal connector. The installation must comply with CAN B149.1 Natural Gas and Propane Installation Code in Canada, or to the National Fuel Gas Code, ANSI Z223.1 in the United States. The minimum recommended piping size is NPS 1/2" for rigid pipe, and 5/8" OD for copper tubing (based on a 20 ft run). Longer runs may require larger sizes to conform with local codes or to conform with CAN B149.1. Propane Gas Installation Code in Canada or to the National Fuel Gas Code, ANSI Z223.1 in the United States. If the enclosure is to house a propane cylinder, the tank portion of the enclosure must be ventilated according to local codes, and must not have communication with the cavity used to enclose the gas grill. The tank can not be stored below the gas grill.

BUILT IN NATURAL GAS HOOK-UP: The piping up to the gas grill is the responsibility of the installer and piping should be located as shown in the built-in instructions. Do not use hose to connect the unit. It must be connected with either rigid pipe, copper tube or an approved flexible metal connector. The installation must comply with CAN B149.1 Natural Gas and Propane Installation Code in Canada, or to the National Fuel Gas Code, ANSI Z223.1 in the United States. The minimum recommended piping size is NPS 1/2" for rigid pipe, and 3/4" OD for copper tubing (based on a 20 ft run). Longer runs may require larger sizes to conform with local codes or to conform with CAN B149.1. Natural Gas Installation Code in Canada or to the National Fuel Gas Code, ANSI Z223.1 in the United States.

Built in units are supplied with a drip pan which holds only a minimal amount of grease. To prevent grease fires, the pan must be cleaned after each use. Access must be provided to the inside of the enclosure to make gas connections.

DANGER: READ ALL INSTRUCTIONS CAREFULLY BEFORE OPERATING GRILL. FAILURE TO FOLLOW THESE INSTRUCTIONS EXACTLY COULD RESULT IN A FIRE CAUSING SERIOUS INJURY OR DEATH.

BUILT-IN OPENING DIMENSIONS DIMENSIONS D'OUVERTURE POUR LES GRILS ENCASTRÉS

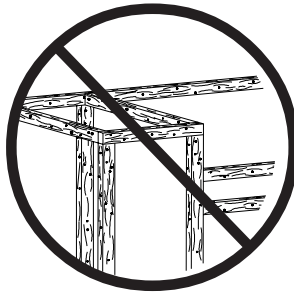

**CABINET FRAME AND CABINET MUST BE
MADE FROM NON-COMBUSTIBLE MATERIAL
LA CHARPENTE DU CABINET ET LE CABINET
DOIVENT ÊTRE FAITS DE MATÉRIAUX
INCOMBUSTIBLES**

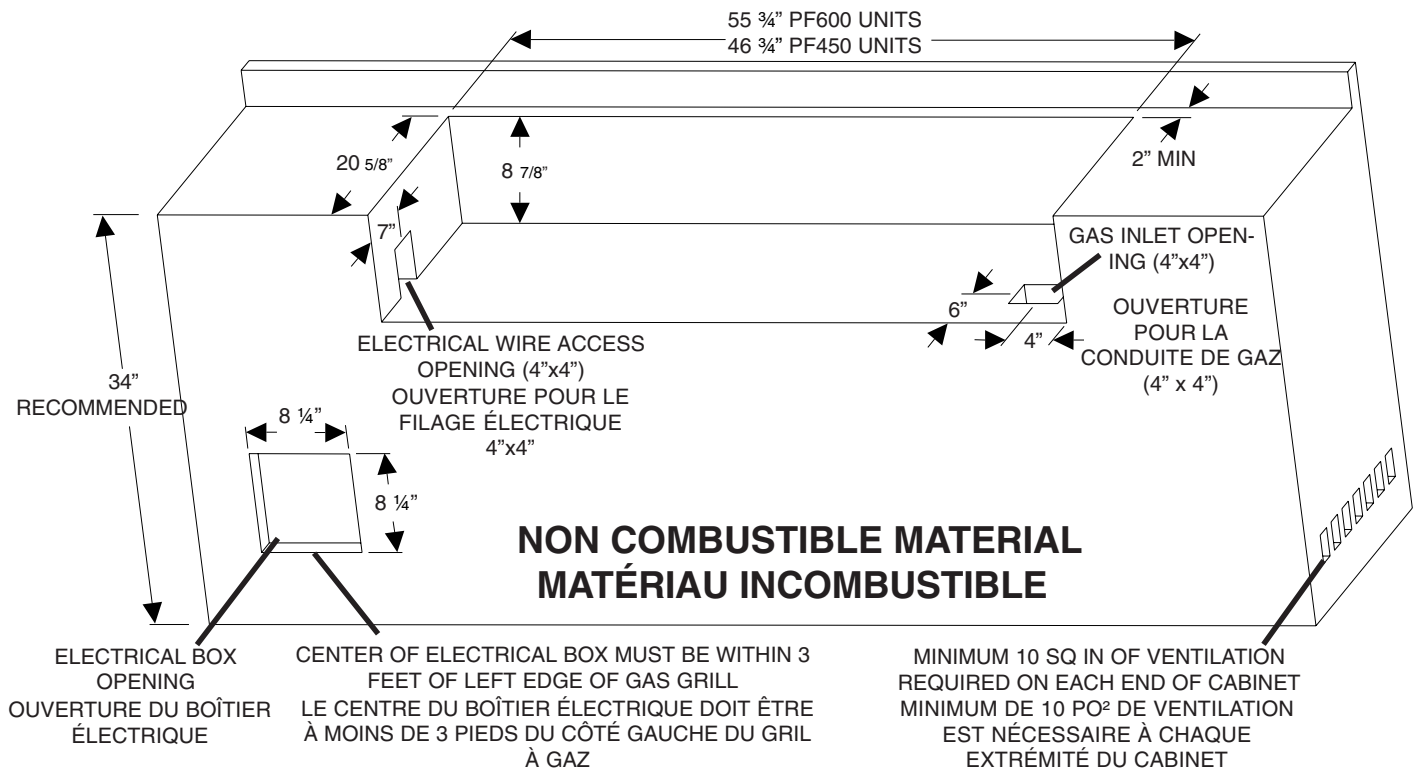

BUILT-IN ACCESSORY OPENING DIMENSIONS DIMENSIONS D'OUVERTURE POUR LES ACCESSOIRES

**NOTE: ACCESSORY FRAMES OVERLAP OPENING BY 1 ½" ON ALL 4 SIDES
LE CADRE DES ACCESSOIRES CHEVAUCHE L'OUVERTURE DE 1 ½" SUR LES QUATRE CÔTÉS.**

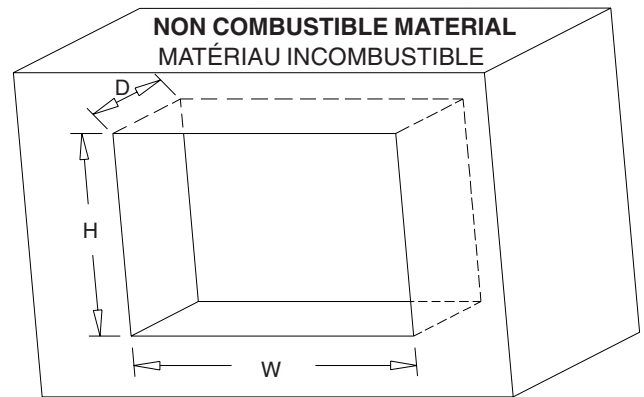

Part # N° de pièce	Description	Picture Illustration	OPENING DIMENSION		
			W	H	D
N370-0069	Flat vertical painted door Porte verticale peinte		13 ¼"	18 ¼"	
N370-0071	Flat vertical stainless steel door Porte verticale en acier inoxydable		13 ¼"	18 ¼"	
N370-0070	Flat horizontal painted door Porte horizontale peinte		18 ¼"	13 ¼"	
N370-0072	Flat horizontal stainless steel door Porte horizontale en acier inoxydable		18 ¼"	13 ¼"	
N370-0356SS	Curved stainless steel door - 308 size Porte cambrée en acier inoxydable - modèle 308		22 ½"	19 ¾"	
N370-0357SS	Curved stainless steel door - 450 size Porte cambrée en acier inoxydable - modèle 450		27"	19 ¾"	
N370-0358SS	Curved stainless steel double door - 600 size Porte cambrée double en acier inoxydable - modèles 600/750		35 ¼"	19"	
N370-0361	PF style stainless steel door Porte en acier inoxydable style Prestige V		17"	23 ¼"	
N370-0359	PF style stainless steel single drawer Tiroir simple en acier inoxydable style Prestige V		17 ¼"	6 ¾"	23"
N370-0360	PF style stainless steel triple drawer Tiroir triple en acier inoxydable style Prestige V		17 ¼"	22 ¾"	23"

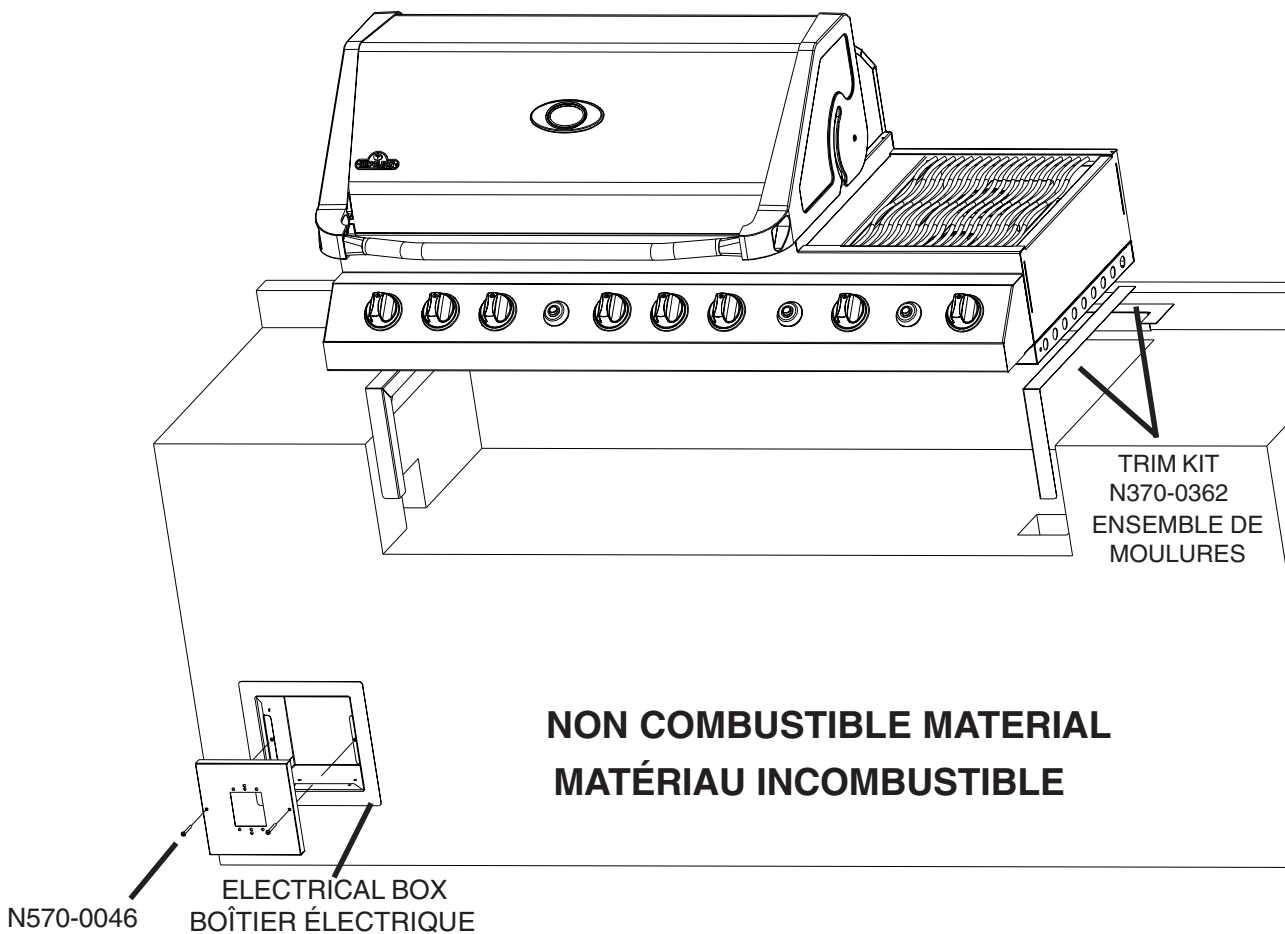

1. Lower the unit into the opening. Feed the wiring harness through the opening on the left hand side. Feed the gas flex connector and regulator down through the opening on the right hand side.
2. Remove the electrical box cover. Install the electrical box into the opening (fasteners not included). Feed the three white wires coming from the grill head into the hole in the back of the electrical box. Ensure the snap bushing is inserted into the hole. Feed the black electrical cord from the inside out through the same bushing. If you are hard wiring directly to the GFI outlet, disconnect the black electrical cord supplied and use the same terminals on the GFI to connect the hard wiring. Attach the white wires to the transformer output. The two wires marked T2 to one output, and the one wire marked T1, to the other output. Re-install the electrical box cover. Plug the power cord into a suitable GFI protected outdoor outlet.
3. For natural gas units, mount the regulator to the cabinet. Connect the gas supply to the inlet side of the regulator. For propane units, connect the gas supply to the end of the flexible connector.
4. If using the optional trim kit, install the rear and side trim pieces using a dab of silicone.
5. Leak test the entire installation before operating the unit.

1. Placez l'appareil dans l'ouverture. Passez le harnais de fils par l'ouverture sur le côté gauche. Acheminez le raccord flexible et le régulateur vers le bas en passant par l'ouverture sur le côté droit.
2. Retirez le couvercle du boîtier électrique. Installez le boîtier électrique dans l'ouverture (pièces de fixation non comprises). Acheminez les trois fils blancs provenant de la cuve de gril dans le trou à l'arrière du boîtier électrique. Assurez-vous que la bague soit insérée dans le trou. Passez le cordon électrique noir de l'intérieur vers l'extérieur à travers la même bague. Si vous câblez le cordon électrique directement à la prise avec interrupteur de défaut à la terre, débranchez le cordon électrique noir fourni et utilisez les mêmes bornes sur la prise avec interrupteur de défaut à la terre pour câbler le cordon électrique. Fixez les fils blancs aux bornes de sortie du transformateur. Les deux fils blancs identifiés T2 à une borne de sortie et le fil identifié T1 à l'autre borne de sortie. Réinstallez le couvercle du boîtier électrique. Branchez le cordon d'alimentation dans une prise extérieure adéquate avec interrupteur de défaut à la terre.
3. Pour les appareils alimentés au gaz naturel, fixez le régulateur au cabinet. Branchez l'alimentation en gaz sur le côté d'arrivée du régulateur. Pour les appareils alimentés au propane, branchez l'alimentation en gaz à l'extrémité du raccord flexible.
4. Si vous utilisez l'ensemble de moulures optionnel, installez les moulures latérales et arrière en appliquant un peu de silicone.
5. L'installation complète doit être vérifiée pour des fuites avant de faire fonctionner l'appareil.

BUILT-IN ACCESSORY DRAWER INSTRUCTIONS

1. Unpack the drawer frame assembly.
2. Remove the drawers from the enclosure by fully extending them and then lifting up to remove them from the slides.
3. Shim the opening to ensure that the enclosure fits snugly into the opening. Ensure that the side shims are located at the same height as the enclosure mounting holes. The bottom of the opening may need to be shimmed as well to ensure that the front of the enclosure is plumb.
4. Once the enclosure is level and square, fasten into place. (Fasteners not included).
5. Re-install the drawers by tipping the back of the drawer down into the slide. Once the wheels are inserted into the slide, lower the front of the drawer until it is level, then push in. Note: if the enclosure is installed with shims that are too thick, the wheel will not engage into the slide. The shim thickness will need to be reduced.
6. Remove the protective coating from all remaining surfaces.

BUILT-IN ACCESSORY DOOR INSTRUCTIONS

1. Unpack the door and frame.
 - a. For the curved stainless steel single doors, remove the door from the frame by lifting the door while holding on to the pivot rod. This will allow the pivot rod to come out of the hole on the bottom of the frame.
 - b. For the curved stainless steel double doors, with the door in the open position, simply lift the doors off of the hinges.
 - c. For the PF style stainless steel door, the door needs to be removed by loosening the center philips screw on the hinge furthest away from the door. This will allow the hinge to separate.
2. Center the frame in the opening. Starting with the hinged side, shim between the frame and side wall of the opening. Ensure the shims are close to the hinge on the PF style doors. When the frame side wall is plumb, fasten it to the cabinet with screws (not provided). Attach the other side of the frame in the same fashion, ensuring the frame is square.
3. Other than on the curved stainless steel double door kit, fasteners are not required on the top and bottom of the frame. The curved stainless steel double door frame must be fastened in the center both at the top and bottom.
4. Once the frame has been secured and checked for squareness, the door can be re-installed.
5. Remove the protective coating from all remaining surfaces.