

This Owner's Manual is provided and hosted by [Appliance Factory Parts](#).



# Napoleon BIPF450 Owner's Manual

[Shop genuine replacement parts for Napoleon BIPF450](#)



[Find Your Napoleon Grill Parts - Select From 264 Models](#)

----- Manual continues below -----

# BUILT-IN SERIES

Creative Spirit, Performance and Quality



**GOURMET GRILLS**  
*Award Winning Products*

[napoleongrills.com](http://napoleongrills.com)



  
**NAPOLEON**  
GOURMET GRILLS  
*Award Winning Products*

## CREATIVE SPIRIT, PERFORMANCE & QUALITY



A passionate dedication to grilling.

Napoleon®, a family owned Canadian company, has been providing home comfort for over 30 years, committed to designing and manufacturing only the finest high efficiency grills, fireplaces and outdoor living products you can depend on.... Proudly backed by the President's Limited Lifetime Warranty.

Superior technology, rock solid performance, balanced design and unparalleled customer service are the hallmark of the Napoleon® name. Your Napoleon grill is designed to excel, offering a cooking experience as gratifying as the wonderful meals you'll create with it.

In the pages ahead, you'll discover the beauty and simplicity of Napoleon style the ideal complement to your patio environment.

*Wishing many unforgettable meals **grilled to perfection.***

# ARCHITECTURALLY DESIGNED



Prestige V  
BIPF600

**PRESTIGE**



## FEATURES:

BIPF450 & BIPF600

- Up to 106,500 BTU's
- Total cooking area: up to 1,100 sq. in.
- Total of 7 burners
- Built-in halogen lights for nighttime grilling and entertaining
- Stainless steel smoker box adds a true smoked flavour to your meals
- Integrated dual side burners for fine cuisine cooking, for a total of 30,000 powerful BTU's
- Commercial quality rotisserie kit with counter balance, stainless steel bracket and four forks for delicious restaurant style cooking using your rear infrared burner
- Includes a heavy duty cover
- Cart models available



BIPF450

 Proudly Made in Canada

Doors and drawers are optional. Island not included.

# ADVENTUROUS FREEDOM



Gemini™  
Prestige II  
BIPT750RBI

INFRARED  
**SIZZLE**  
**ZONE** 

## FEATURES:

BIPT750RBI

- Up to 92,500 BTU's
- Total cooking area: up to 1,160 sq. in.
- Total of 6 burners
- Commercial quality rotisserie kit with counter balance and four forks for delicious restaurant style cooking using your rear infrared burner
- Twin head cooking system
- Cart models available

 Proudly Made in Canada

Doors and drawers are optional. Island not included.

# ROCK SOLID PERFORMANCE



Prestige II  
BIPT600RB

**INFRARED**  
**SIZZLE**  
**ZONE** 

Also available as an  
infrared model  
(BIPT600RBI)

## FEATURES:

BIPT600RB

- Up to 82,500 BTU's
- Total Cooking Area: up to 922 sq. in.
- Total of 5 burners
- Commercial quality rotisserie kit with counter balance and four forks for delicious restaurant style cooking using your rear infrared burner
- Cart models available

 Proudly Made in Canada

Doors and drawers are optional. Island not included.

# ATTENTION TO DETAIL



Prestige II  
BIPT450RB

**INFRARED**  
**SIZZLE**  
**ZONE** 

Also available as an  
infrared model  
(BIPT450RBI)

## FEATURES:

### BIPT450RB

- Up to 61,000 BTU's
- Total cooking area: up to 695 sq. in.
- Total of 4 burners
- Heavy duty rotisserie kit with counter balance and two forks for delicious restaurant style cooking using your rear infrared burner
- Cart models available

 Proudly Made in Canada

Doors and drawers are optional. Island not included.

VALUE PACKED



Ultra Chef™  
BIU405RB

**FEATURES:**

BIU405RB

- Up to 59,000 BTU's
- Total Cooking Area: up to 570 sq. in.
- Total 4 burners
- Porcelainized cast iron WAVE™ reversible channel cooking grids
- RADIANT WAVE™ stainless steel sear plates
- Cart models available

 Proudly Made in Canada

Doors and drawers are optional. Island not included.

# TECHNOLOGICAL INDULGENCE



Mirage™  
BIM730RBI

INFRARED  
**SIZZLE  
ZONE**

## FEATURES:

BIM730RBI, BIM605RBI & BIM485RB

- Up to 96,000 BTU's
- Cooking Area: up to 1,025 sq. in.
- Up to 6 burners
- Unique, JETFIRE™ ignition system for easy start ups
- Engaging i-GLOW™ backlit control knobs for late night entertaining
- Optional commercial quality rotisserie kit with counter balance and two forks for delicious restaurant style cooking using your rear infrared burner. Flexible halogen light for night time cooking (BIM605RBI, BIM730RBI only)
- Cart models available

**i-GLOW™**  
BACKLIT  
TECHNOLOGY



BIM485RB



BIM605RBI



BIM730RBI

Doors and drawers are optional. Island not included.

# OUTDOOR KITCHEN OASIS™



OASIS 200 shown with BIM485RB Grill Head

**INFRARED**  
**SIZZLE**  
**ZONE**

Also available as an infrared model (BIPT450RBI, BIPT600RBI)

## FEATURES:

### OASIS™ MODULAR ISLANDS

- Customize your own modular island components to suit your individual needs. There are four island configurations for reference (OASIS™ 400, 300, 200, 100)
- Powder coated galvanized steel
- Stainless steel doors and drawers for longevity
- Knock outs for easy electrical and gas piping installations
- Quick adjustment leveling feet on each modular unit
- Convenient cash and carry design
- Endless design possibilities
- Countertops not included
- See the OASIS™ modular brochure for full details



BIPT450RB

BIPT600RB

BIPT750RBI

BIM485RB

BIM605RBI

BIM730RBI

# OASIS™ MODULAR ISLAND CONFIGURATIONS



OASIS 300 shown with BIM605RBI Grill Head



OASIS 100 shown with BIM485RB Grill Head



OASIS 400 shown with BIPT750RBI Grill Head

# OASIS™ MODULAR ISLAND COMPONENTS



Under Grill Cabinets  
Models: IM-UGC450,  
IM-UGC600  
IM-UGC485,  
IM-UGC605,  
IM-UGC730  
IM-UGC730



Under Grill Cabinets  
Model IM-UGC 300  
fits side burners  
BISZ300,  
BISZ300FT,  
BISB245



Under Grill Cabinet  
Model: IM-UGC750



Three Drawer Cabinet  
Model: IM-3DC



Two Drawer Cabinet  
Model: IM-2DC



Waste Drawer with  
Paper Towel Holder  
Model: IM-WDC



Propane or Universal  
Cabinets  
Models: IM-UTC (shown)  
IM-UDC



Fridge Cabinet Assembly  
Models: IM-FHR  
IM-FHL  
includes Danby 2.5 cubic ft.  
fridge



Wall Spacer  
Model: IM-WSF



Cabinet Transitions  
Model: IM-45T = 45°



Cabinet End Panel  
Model: IM-CEP



Ice Bucket Holder  
Model: IM-IBA

# BUILT-IN ISLAND DOORS & DRAWERS



Flat Vertical Stainless Steel Door  
Model: N370-0071



Flat Horizontal Stainless Steel Door  
Model: N370-0072



Deluxe Flat Stainless Steel Door Kit With Curved Stainless Steel Handle  
Model: N370-0361



Curved Stainless Steel Double Doors  
Model: N370-0358SS



Curved Stainless Steel Door  
Model: N370-0356SS



Curved Stainless Steel Door  
Model: N370-0357SS

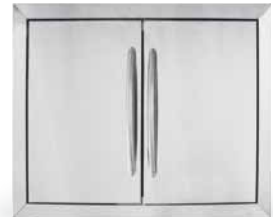

Flush Mount Stainless Steel Double Door  
Model: N370-0502  
N370-0503



Deluxe Stainless Steel Triple Drawer With Curved Stainless Steel Handles  
Model: N370-0360



Deluxe Stainless Steel Single Drawer With Curved Stainless Steel Handle  
Model: N370-0359



Zero Clearance Kits  
Models: BIZC450/600  
Size: Fits any 450 or 600 models. (excluding PF models)



13,500 BTU Drop-in Side Burner  
Model: N370-0504(LP)  
N370-0505 (NG)

# ADDITIONAL BURNER ACCESSORIES



30,000 BTU Infrared SIZZLE ZONE™ Burner  
Model: BISZ300 With LIFT EASE™ Roll Top Lid  
BISZ300FT With Stainless Steel Flat Cover  
Size: 465 sq. in. total cooking space - 300 sq. in. main



30,000 BTU Double Side Burner  
Model: BISB245  
Size: 245 sq. in. total cooking space



# THE HEART OF A NAPOLEON® GRILL



## Heavy Duty 304 Stainless Steel Cooking System

The even, consistent heat from high and hot to low and slow.

- Patented WAVE™ rod cooking grids for those Napoleon® trademark sear lines
- Patented self cleaning sear plates for reduced flare-ups
- Durable 16 gauge burners for controlled, even heat



## Oven-like Performance

Napoleon's LIFT EASE™ roll top lid tucks neatly back giving you more space on your patio or deck. The tightly sealed lid will not be compromised by prevailing winds. Maximum heat is retained in the streamlined, double-walled lid for oven-like performance.

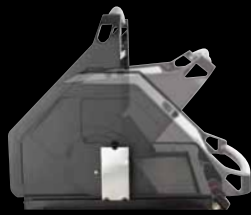

## Variety of Burner Styles

- Rear stainless steel rotisserie burner heat waves seal and lock in the juices quickly for superior tenderness. Restaurant style results and perfect self-basting roasts every time. (Heavy duty rotisserie kit with counter balance, stainless steel rotisserie bracket and forks available with most models).
- Ceramic bottom burner with thousands of evenly spaced flame ports generate infrared radiant energy. The intense, 1800° heat of the infrared SIZZLE ZONE™ instantly locks in valuable juices, mouth-watering flavour, and tantalizing aroma, to deliver an amazing taste sensation. Go ahead, lift the lid, reach for the red knob.
- Tube burners run front to back for precise heat control, allowing for independent use of each cooking zone such as direct or indirect cooking.



## Charcoal Flavour From Your Gas Grill

Napoleon's optional charcoal tray is designed to let you add the fun & flavour of charcoal anytime, on your gas grill. Simply replace a sear plate with the charcoal tray, add charcoal and light with your gas grill.



## Electronic Ignition

Simple one touch electronic ignition ensures trouble free starts.



## Universal Rotisserie Kit

Every Napoleon® Prestige™ grill (excluding P450) comes with a complete rotisserie kit to use with your rear burner. The rotisserie kit allows you to cook larger roasts, chickens and turkeys using the restaurant style method of rotating the meat while cooking from the rear burner, self basting in it's own juices.



## Temperature Gauge

The ACCU-PROBE™ temperature gauge lets you safely and instantly read the internal temperature of your grill with the lid closed. It works like your conventional oven and features a heat-resistant stainless steel probe. This thermometer has a wide temperature measurement range from 0° to 370°C (0° to 700°F) and includes the ideal smoking and searing range.



## Napoleon® Limited Lifetime Warranty

A growing number of people are discovering the joys of cooking on their Napoleon® grill. We are here to ensure your love for your Napoleon® grill is a bond that continues to bring you and your family a sensational grilling experience for years to come. Your purchase includes exclusive access to our customer care hotline and President's Limited Lifetime warranty, providing you with peace of mind.

# THE MOST VERSATILE COOKING STYLES AVAILABLE

## Direct Cooking

This method of cooking utilizes all burners, cooking the food directly above the flame “GRILLING” style, for searing steaks, other meats or vegetables. Keeping the lid down reduces the cooking time and cooks through to the center faster than with the lid up. Anything that is less than 2 inches in thickness should be cooked by direct grilling. These are things that generally cook quickly and benefit from the fast cooking of a hot grill. Front to back burners were designed for precise heat control, allowing for independent use of each cooking zone.



## Indirect Cooking

Indirect grilling is similar to baking. The food is placed above the unlit burner instead of directly over the flame. This can be achieved by only igniting some of the burners – light one side on high and cook the food on the other. The food will cook more evenly as it is not exposed to direct heat from the burners. This is an excellent way to cook tough cuts of meat, like brisket and ribs, that require long, slow cooking at a low or moderate heat. Indirect grilling allows you to work over a more moderate temperature (275° to 350°) and makes it easy to introduce a smoker pipe for extra flavour. For chicken, game, turkey, roasts, ham, vegetables, bread or combinations, the indirect cooking method gives great results every time. There is little need to turn the food. You can place the food directly on the grids or in a cooking pan.



## Rotisserie Cooking

Rotisserie cooking allows the food to self-baste, sealing in the juices while browning the outside surface. Use the rotisserie method of cooking for large cuts of meat like roasts, poultry or legs of lamb. There are so many advantages to rotisserie cooking. Meats are generally juicier, self-basted and slow roasted. You can use the rotisserie method if your grill comes with a rear rotisserie burner, which requires much less attention than any other cooking method. The rotisserie burner is a nice feature because it automatically sets you up for direct, even heating.



## Infrared Bottom Burner Cooking

Do you want to make the perfect steak? The intense 1800° heat instantly sears the meat, locking in the juices. Larger cuts of meat may be moved to the side of the grill to continue cooking.

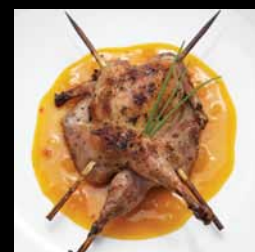

## Convection Style Cooking

Bread, buns, cakes and pizzas can be cooked to perfection under the grill hood. For convection cooking, follow the same instructions as for the indirect cooking method. Your grill comes with a tightly sealed lid for heat retention, giving oven-like performance.



## Smoking

Place wet wood chips into the smoker tube and place over the left burner, then turn the burner on. Place your meat over the right burner, but do not turn on that burner. You are using the indirect cooking method. Smoke the meat for several hours under a closed lid. To achieve maximum flavour, fresh wood chips may be added several times during the cooking process.



## Charcoal Cooking

Unique to Napoleon®! Optional charcoal trays. Gives you the freedom to switch from gas to charcoal with relative ease. With charcoal you can utilize indirect cooking as well as direct cooking.

# INSTALLATION SPECIFICATIONS

## OASIS™ MODULAR ISLAND SAMPLE

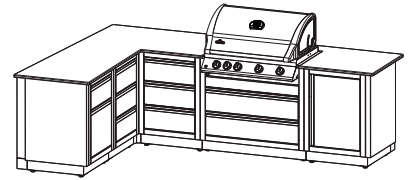
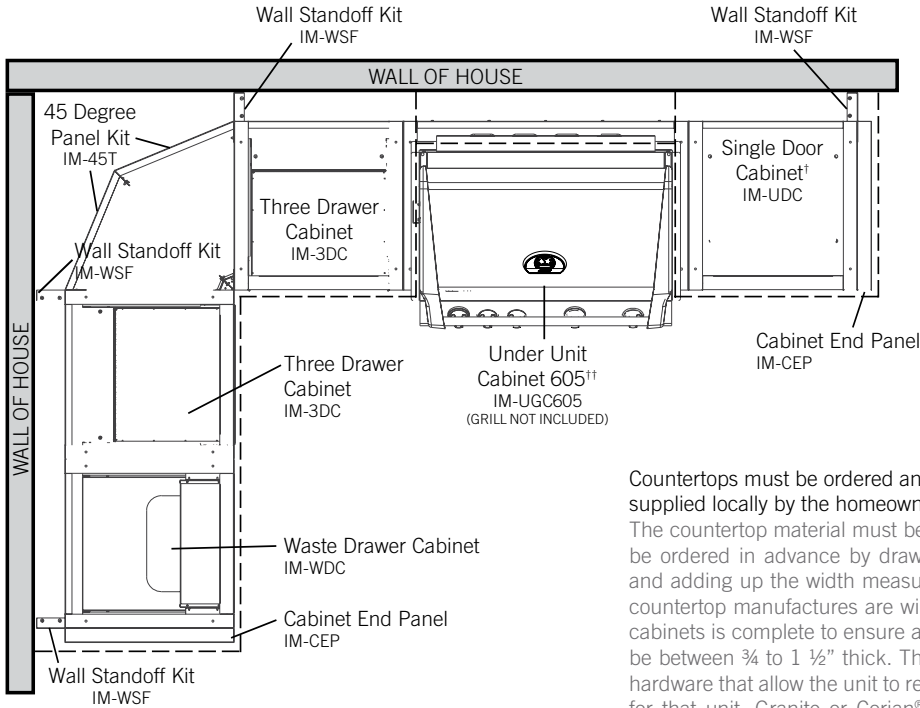

Countertops must be ordered and supplied locally by the homeowner.

The countertop material must be non-combustible if a grill is to be installed into it. They can be ordered in advance by drawing out the floor plan of how the cabinets will be situated and adding up the width measurements, allowing 1-2 inches of countertop overhang. Most countertop manufacturers are willing to come and take measurements after assembly of the cabinets is complete to ensure a perfect fit. For best results the countertop thickness should be between 3/4 to 1 1/2" thick. The built-in grill head comes with stainless steel brackets and hardware that allow the unit to rest on the countertop above the corresponding island cabinet for that unit. Granite or Corian® are excellent choices of countertop materials. Decorative countertops made of ceramic tile set on top of cement tiling board can be selected to match your surrounding backyard furniture colour.

## BUILT-IN SAMPLE

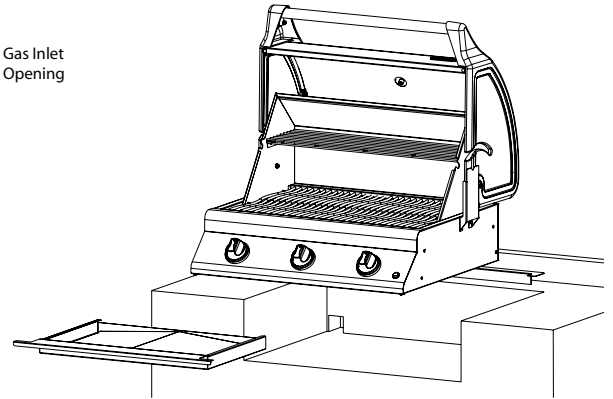
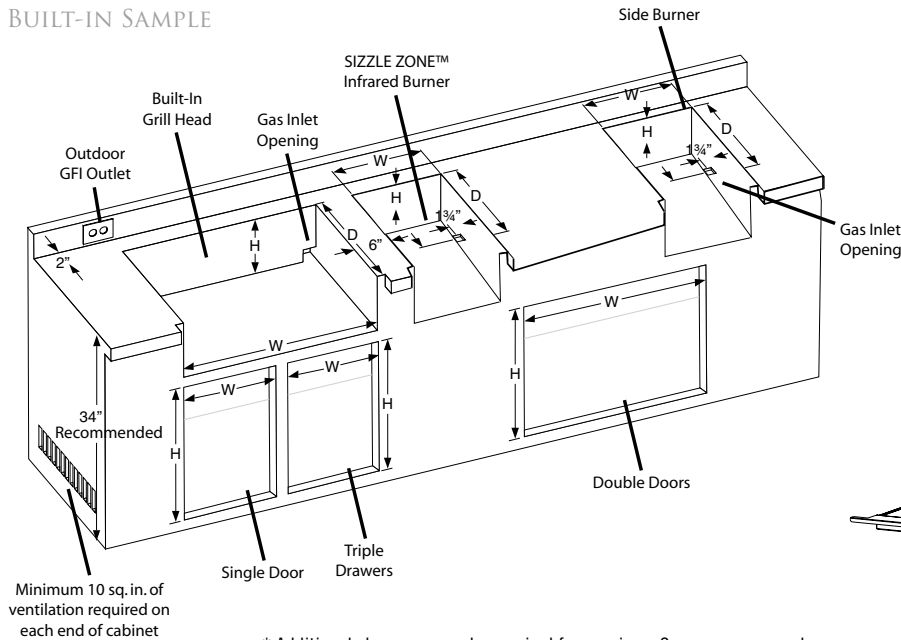

\* Additional clearance may be required for openings. See owners manual

Please use manual to properly assemble your built-in grill. Refer to the main manual for operating, cleaning, and maintenance instructions. This grill is designed for non-combustible enclosures only (unless the Napoleon® zero clearance kit is utilized), and must be installed and serviced by a qualified installer to local codes.

**BUILT-IN PROPANE GAS HOOK-UP:** The piping up to the gas grill is the responsibility of the installer and piping should be located as shown in the built-in instructions. The installation must comply with CAN B149.1 Natural Gas and Propane installation code in Canada, or to the National Fuel Gas code, ANSI Z223.1 in the United States. The tank can not be stored below the gas grill. Built-in units are supplied with a drip pan which holds only a minimal amount of grease. To prevent grease fires, the pan must be cleaned after each use.

**Drawings for reference only. Minimum 6" clearance required between grill and other appliance. Specifications subject to change without notice.**

# THE ANATOMY OF THE PERFECT OUTDOOR KITCHEN

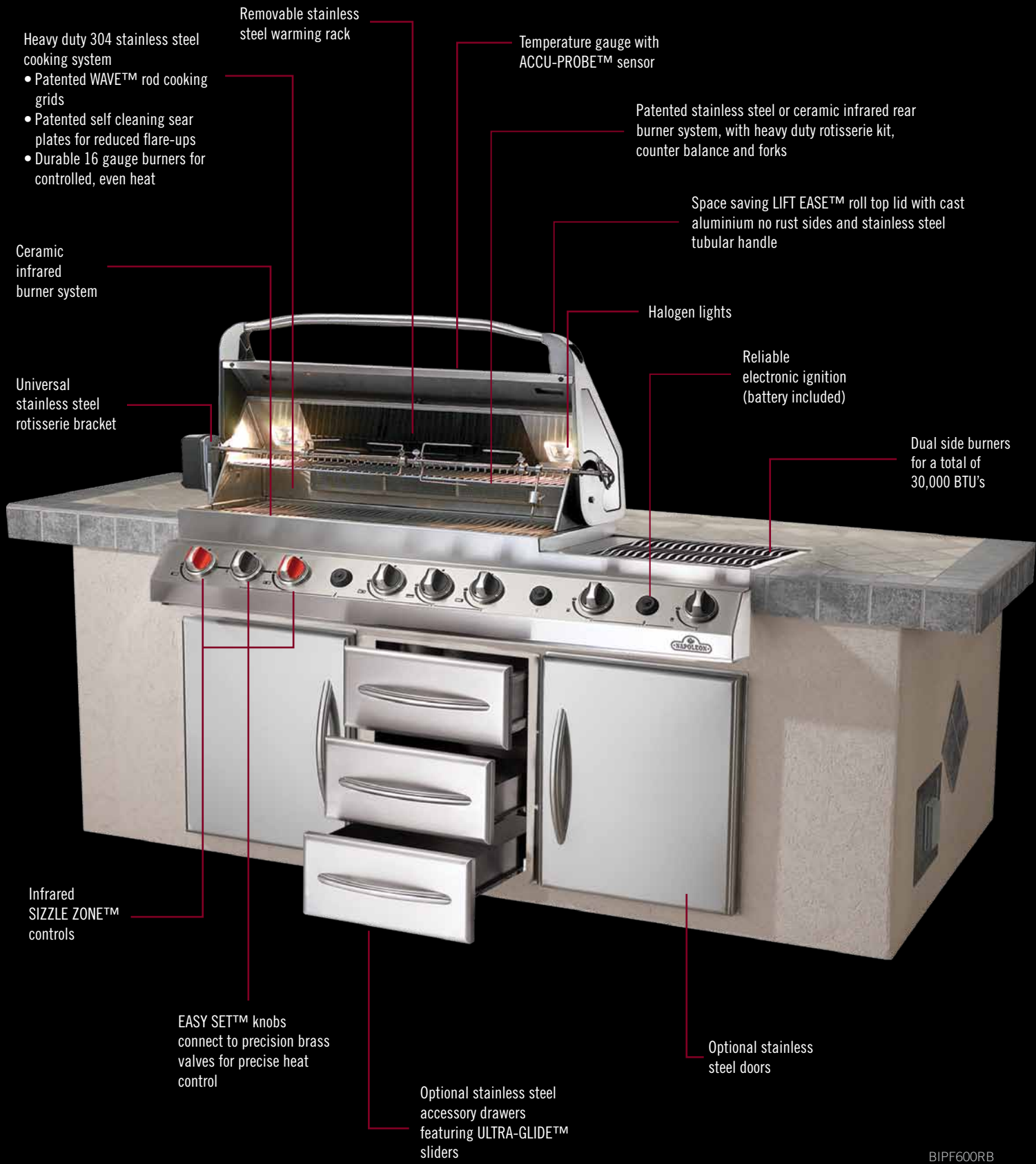

Heavy duty 304 stainless steel cooking system

- Patented WAVE™ rod cooking grids
- Patented self cleaning sear plates for reduced flare-ups
- Durable 16 gauge burners for controlled, even heat

Removable stainless steel warming rack

Temperature gauge with ACCU-PROBE™ sensor

Patented stainless steel or ceramic infrared rear burner system, with heavy duty rotisserie kit, counter balance and forks

Space saving LIFT EASE™ roll top lid with cast aluminium no rust sides and stainless steel tubular handle

Ceramic infrared burner system

Halogen lights

Reliable electronic ignition (battery included)

Universal stainless steel rotisserie bracket

Dual side burners for a total of 30,000 BTU's

Infrared SIZZLE ZONE™ controls

EASY SET™ knobs connect to precision brass valves for precise heat control

Optional stainless steel accessory drawers featuring ULTRA-GLIDE™ sliders

Optional stainless steel doors

BIPF600RB

SPECIFICATIONS	BIPF600	BIPF450	BIPT750	BIPT600	BIPT450	BIM730	BIM605	BIM485	BIU405RB
LIFT EASE™ roll top lid	S	S	S	S	S	S	S	S	S
ACCU PROBE™ temperature gauge	S	S	S	S	S	S	S	S	S
Total cooking surface (sq. in.)*	1100	890	1160	922	695	1016	843	675	570
Electronic ignition	S	S	S	S	S	S	S	S	S
Rear burner igniter	S	S	S	S	S	S	S	-	-
Infrared ceramic bottom burners	2	1	2	-	-	1	1	-	-
304 Stainless steel bottom burners	2	2	3	4	3	4	3	3	3
Infrared rear rotisserie burner	S	S	S	S	S	S	S	-	-
304 Stainless steel WAVE™ rod cooking grids	S	S	S	S	S	S	S	S	-
Porcelain cast iron WAVE™ reversible channel cooking grids	-	-	-	-	-	-	-	-	S
iGlow™ knobs	-	-	-	-	-	S	S	S	-
EASY SET™ knobs	S	S	S	S	S	-	-	-	S
Rotisserie and forks	4	4	4	4	2	2	2	-	0
Rotisserie with flexible halogen light	-	-	-	-	-	S	S	S	-
Removable drip pan	S	S	S	S	S	S	S	S	S
Warming rack	S	S	S	S	S	S	S	S	S
President's Limited Lifetime Warranty	S	S	S	S	S	S	S	S	S
DIMENSIONS (OPENING SIZE)	BIPF600	BIPF450	BIPT750	BIPT600	BIPT450	BIM730	BIM605	BIM485	BIU405RB
Width (in)	55 3/4"	46 3/4"	49 3/4"	37 3/4"	29 1/2"	43 1/4"	36 1/2"	29 3/4"	27 1/2"
Height (in)	8 7/8"	8 7/8"	9 5/8"	8 7/8"	8 7/8"	7 1/2"	7 1/2"	7 1/2"	12"
Depth (in)	20 5/8"	20 5/8"	20 5/8"	20 5/8"	20 5/8"	21 3/8"	21 3/8"	21 3/8"	16 3/4"

S=Standard \* All lid openings require a minimum of 2" clearance behind the unit, except the Ultra Chef series. Ultra Chef requires 3" clearance. Refer to owners manual for individual models. - Dimensions subject to change. Refer to manual for accurate dimensions

#### OPENING DIMENSIONS

DOORS & ACCESSORIES	Part Number	Width	Height	Depth
Flat Vertical Painted Door	N370-0069	13 1/4"	18 1/4"	-
Flat Vertical Stainless Steel Door	N370-0071	13 1/4"	18 1/4"	-
Flat Horizontal Painted Door	N370-0070	18 1/4"	13 1/4"	-
Flat Horizontal Stainless Steel Door	N370-0072	18 1/4"	13 1/4"	-
Curved Stainless Steel Door	N370-0356SS	22 1/2"	19 3/4"	-
Curved Stainless Steel Door	N370-0357SS	27"	19 3/4"	-
Curved Stainless Steel Double Door	N370-0358SS	35 1/4"	19"	-
Flat Stainless Steel Door	N370-0361	17"	23 1/4"	-
Flushed Mount Stainless Steel Double Door	N370-502	28 1/4"	20 1/4"	-
Flushed Mount Stainless Steel Double Door	N370-503	37 3/4"	20 1/4"	-
Stainless Steel Single Drawer	N370-0359	17 1/4"	6 3/4"	23"
Stainless Steel Triple Drawer	N370-0360	17 1/4"	22 3/4"	23"
Infrared SIZZLE ZONE™ Burner With Roll Top	BISZ300	20 1/8"	9 5/8"	20 5/8"
Infrared SIZZLE ZONE™ With Flat Top	BISZ300FT	20 1/8"	9 5/8"	20 5/8"
Double Side Burner	BISB200	20 1/8"	8 7/8"	20 5/8"
Single Side Burner	N370-0057/58	13 1/2"	4"	17 1/2"
Side Burner	N370-0504/05	18"	15"	4 1/2"
Zero Clearance (1) 29"	BIZC450	35 1/8"	22 15/16"	11 1/8"
Zero Clearance (2) 37"	BIZC600	44 1/8"	22 15/16"	11 1/8"

#### DIMENSIONS

OASIS™ MODULAR COMPONENTS	Part Number	Width	Height	Depth
Under Grill Cabinet - 450 series	IM-UGC450	33 3/4"	35"	24"
Under Grill Cabinet - 600 series	IM-UGC600	42"	35"	24"
Under Grill Cabinet - 750 series	IM-UGC750	53 3/4"	35"	24"
Under Grill Cabinet - 485 series	IM-UGC485	33 3/4"	35"	24"
Under Grill Cabinet - 605 series	IM-UGC605	40 1/2"	35"	24"
Under Grill Cabinet - 730 series	IM-UGC730	47 1/4"	35"	24"
Under Grill Cabinet - 300 series	IM-UGC300	24"	35"	24"
Propane Tank Cabinet - universal door	IM-UTC	24"	35"	24"
Universal Door Cabinet	IM-UDC	24"	35"	24"
Fridge Cabinet	IM-FHR/FHL	24"	35"	24"
Three Drawer Cabinet	IM-3DC	24"	35"	24"
Two Drawer Cabinet	IM-2DC	24"	35"	24"
Waste Drawer with Paper Towel Holder	IM-WDC	24"	35"	24"
Cabinet End Panel	IM-CEP	24"	31"	2"
Cabinet Transitions - 45 degrees	IM-45T	18 3/8"	35"	-
Wall Spacer	IM-WSF	4"	35"	1 1/2"
Ice Bucket Holder	IM-IBA	19 1/8"	1 3/16"	16"

#### PRESTIGE V SERIES



BIPF600RSB

BIPF450RSB

#### PRESTIGE II INFRARED SERIES



BIPT750RBI

BIPT600RBI

BIPT450RBI

#### PRESTIGE II SERIES



BIPT600RB

BIPT450RB

#### ULTRA CHEF SERIES



BIU405RB

#### MIRAGE™ SERIES



BIM730RBI

BIM605RBI

BIM485RB

#### OASIS™ SERIES\*



OASIS 100

OASIS 200

OASIS 300

OASIS 400

\* Example Configurations Only

# A PASSIONATE DEDICATION TO GRILLING



Electric Fireplaces



BBQ Accessories



Gas Fireplaces



Wood Stoves



Waterfalls



Patio Heaters



Patioflame®



Outdoor Gas Fireplaces



Approved by Intertek Testing Services to standards in the USA and Canada: ANSI Z21.58/CSA 1995 CSA-1.6 - Outdoor Cooking Gas Appliances. All specifications and designs are subject to change without prior notice due to ongoing product improvements. Consult your owner's manual for complete installation and operating instructions and check all local and national Building Codes and Regulations. Not all features available on all models. Napoleon® is a registered trademark of Wolf Steel Ltd. Patent U.S.5, 676,048-5,617, 778, DES433875, 417497, Patents Pending. The red knob design is a trademark of NAC. Images and colors may not be exactly as shown.



- 214 Bayview Drive, Barrie, Ontario, Canada L4N 4Y8
- 103 Miller Drive, Crittenden, Kentucky, USA 41030
- 7200 Trans Canada Highway, Montreal, Quebec H4T 1A3
- Pomona, California 91766

PHONE: 705-726-4278 • FAX: 705-725-2564  
 napoleongrills.com  
 info@napoleonproducts.com

Authorized Dealer

