

ELECTRIC GRILL USE AND CARE MANUAL
READ AND SAVE THIS MANUAL FOR FUTURE REFERENCE
GRIL ÉLECTRIQUE MANUEL D'UTILISATION ET D'ENTRETIEN
VEUILLEZ LIRE ET CONSERVER CE MANUEL

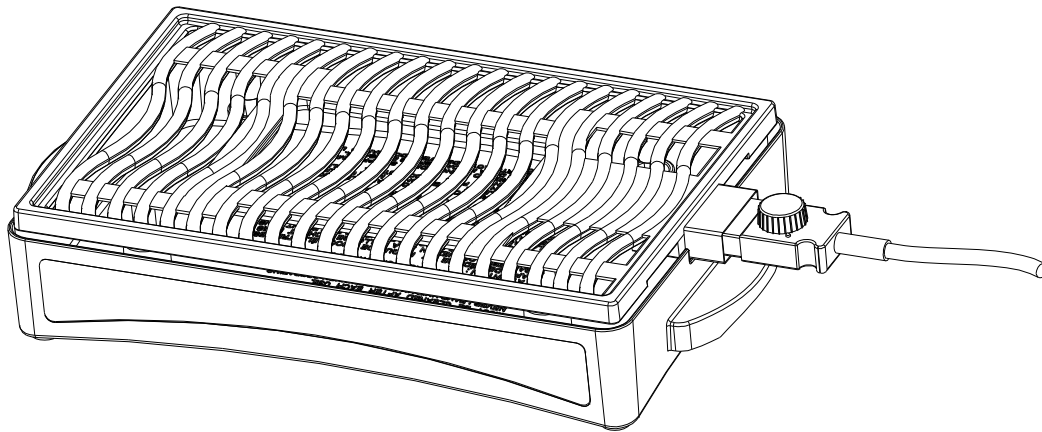

EG215

ELECTRIC GRILL / GRIL ÉLECTRIQUE

CONGRATULATIONS / FÉLICITATIONS

On your purchase of a Napoleon Electric Grill! To learn more about our products visit us at
www.napoleongrills.com

Pour votre achat d'un gril électrique Napoléon! Pour en connaître davantage sur nos produits, visitez-nous au
www.napoleongrills.com

MANUFACTURED FOR/FABRIQUÉ POUR
NAPOLEON APPLIANCE CORP., 214 BAYVIEW DRIVE.,
BARRIE, ON CANADA
L4N 4Y8
(705)726-4278

WARNING

FOR YOUR SAFETY READ ALL INSTRUCTIONS IN THIS MANUAL BEFORE COOKING ON THE GRILL. FAILURE TO FOLLOW THESE INSTRUCTIONS COULD RESULT IN SERIOUS PERSONAL INJURY AND/OR PROPERTY DAMAGE.

IMPORTANT SAFEGUARDS

- Read all instructions before operating grill.
- Keep children and pets away from hot grill.
- Use only on properly grounded outlet. If using outdoors use only with GFI (Ground Fault Interrupter).
- Do not operate with a damaged cord or plug or after the appliance malfunctions or has been damaged in any manner. Return appliance to the nearest authorized service facility for examination, repair, or adjustment.
- Always attach plug to grill first then plug cord into wall outlet. To disconnect, turn control to off, unplug from wall. (grasp plug and remove, do not pull on cord).
- To protect against electric shock, do not immerse the control box, cord set or the plug in water or other liquid. Do not use grill within 10ft of pool, pond or other body of water.
- Do not use grill when raining. Keep grill and electric controller dry and out of rain at all times.
- Do not let the cord hang over edge of table or touch hot surfaces.
- Unplug grill from power outlet after use and before cleaning.
- Always use the appliance on a dry, level surface.
- Hot while in use; do not touch grill plate or base while operating. Use handles or control knobs.
- Allow grill to cool before cleaning, or removing parts.
- Use extreme caution when moving grill containing hot grease. It is recommended to allow grill to cool prior to moving.
- To avoid damaging the protective coating on your grill do not cut food on the grill plate.
- Keep grill 24" (2ft) away from walls and other combustible materials.
- Cooking spray can ignite and/or flare up and must not be used on the grill at anytime.
- Do not use or store gasoline, kerosene, or other flammable liquids within 20ft of this grill while in use.
- In case of fire turn controller to "OFF" unplug grill from outlet, and allow fire to burn out. Do not use water to put out a fire in this or any other electrical appliance.
- The use of accessory attachments not recommended by manufacturer may cause injuries and damage the appliance.
- This appliance is intended for household use only, not for commercial use.
- Do not place on or near a hot gas or electric burner, or in a heated oven.
- Do not use appliance other than for intended use.
- Fuel, such as charcoal briquettes, is not to be used with appliance.
- A short power-supply cord should be used to reduce the risk resulting from becoming entangled in or tripping over a longer cord.
- Extension cords are available and may be used if care is exercised in their use.
- If extension cord is used:
 - i) The marked electrical rating of the cord set or extension cord should be at least as great as the electrical rating of the appliance; and
 - ii) The cord should be arranged so that it will not drape over the countertop or tabletop where it can be pulled on by children or tripped over unintentionally.
- The appliance is of the grounded type, the extension cord should be a grounded-type 3-wire cord.
- Outdoor extension cords should be used with outdoor use products and are surface marked with the suffix letter "W" and labelled with a tag stating "for use with outdoor appliances".
- The connection to an extension cord should be kept dry and off the ground.
- Store products when not in use - out of the reach of children.
- Do not clean this product with a water spray or other liquid while operating.

SAVE THESE INSTRUCTIONS

NEED HELP?

For service, repair, or any questions regarding your grill, call our customer care department at 1-866-820-8686 between 9am and 5 pm (Eastern Standard Time).

FULL ONE-YEAR WARRANTY

Napoleon warrants this product against any defects in material or workmanship for a period of one year from original date of purchase (to the original purchaser only). This warranty does not include damages due to misuse, lack of maintenance, grease fires, hostile environments, accidents, alterations, abuse or neglect. Parts installed from other manufacturers will nullify this warranty.

WARRANTY CLAIM

If you have a claim under this warranty call our customer care line listed above. Proof of purchase is required (sales receipt).

2 Please have model number ready prior to calling.

INSTRUCTIONS FOR USE

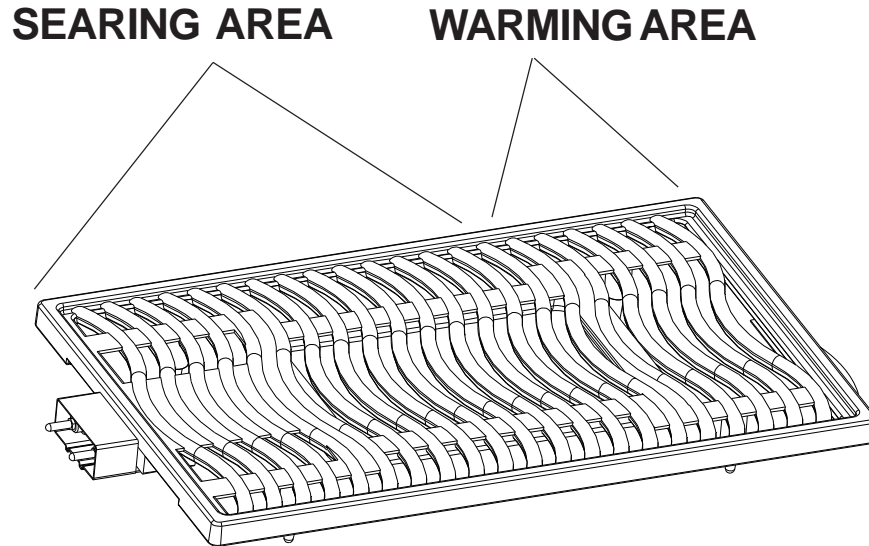

1. Before using the grill for the first time follow the cleaning instruction section of this manual.
2. Plug into a properly grounded electrical outlet (GFI).
3. Spread a little vegetable oil on the grill plate before the grill is turned on (this will help treat your grill surface).
4. Set temperature control to desired setting. Indicator light will come on. When desired setting is reached indicator light will go off. During cooking, indicator light may cycle off and on as thermostat maintains temperature.
5. Put the food directly on the grill. Never put aluminum foil or utensils on the grill plate.
6. Use only plastic or wooden utensils on the grill surface.
7. Grill the food according to your own taste. Grilling time depends on the kinds of food being cooked, initial temperature of the food and its thickness. This grill is suitable for all types of meat, fish, vegetables, etc.
8. When food has been cooked to desired temperature, turn the control knob to "off". Unplug the grill.

EXTENSION CORD USE:

A short power supply cord is provided to reduce risk of becoming entangle in or tripping over a long cord. Extension cords may be used if care is exercised in their use.

If extension cord is used:

1. The marked electric rating of the cord should be at least 120V, 15A.
2. The longer cord should be arranged so that it will not drape over the countertop or table where it can be pulled on by children or tripped over unintentionally.

THREE PRONG PLUG

This appliance is equipped with a three prong plug. A safety feature intended to help reduce the risk of electrical shock. If you are unable to insert the plug into the outlet, contact a qualified electrician to replace the outlet. Do not attempt to override the safety feature of the 3 prong plug by modifying the plug in any way.

ELECTRIC POWER

If the electric circuit is overloaded with other appliances, your appliance may not operate. It should be operated on a separate electrical circuit from other appliances. If you are not sure contact a qualified electrician.

CAUTION: To prevent damage to countertop or table top, use a non-flammable, heat resistant placemat between the base and the countertop or table top surface. Never place on carpet, furniture or other combustible materials. Be cautious of hot splashing oil during cooking.

CLEANING INSTRUCTIONS

1. Always unplug the grill and let the appliance cool down before cleaning.
2. Remove temperature control probe from grill plate. Do not immerse control probe into water. The grill is immersible only after the temperature control probe and cord are removed.
3. Remove any excess grease from the base of the grill. Wash the grill plate and base with hot soapy water. Do not use abrasive cleaning powders or sharp objects to clean the grill plate as it may damage the coating.
4. Clean the outer surface of the temperature control probe with a damp cloth. Non abrasive cleaner may be used if necessary.
5. Do not place the grill in the dishwasher, it must be hand washed.
6. There are no user serviceable parts. Any servicing other than indicated in this instruction manual must be performed by an authorized service person. Do not attempt to open appliance.

TROUBLESHOOTING

Problem	Possible Causes	Solution
No heat.	Temperature probe turned off. No power. Faulty temperature probe or grill plate.	Turn temperature probe to maximum setting. Ensure temperature probe is fully seated in grill plate. and properly plugged into outlet. Try another outlet. Check for tripped circuit breaker. Reset. Turn temperature probe to maximum setting. Pre-heat grill with lid closed for 10 minutes. Replace temperature probe or grill plate.
Low heat.	Improper preheating. Excessive buildup in base of grill.	Preheat 10 minutes. Increase probe setting. Clean out excessive debris in base.
Excessive flare-ups/ uneven heat.	Excess fat in meat. Excessive cooking temperature. Grease buildup.	Trim fat from meat before grilling. Adjust temperature as needed. Clean grill.
Circuit breaker trips or fuse blows.	Power Surge. Another appliance plugged into same circuit as grill. Moisture or water in temperature probe or electrical connections.	Turn controller to OFF position before plugging into electrical outlet. Do not use other electrical appliances on same circuit. Keep probe and electrical components dry.

PARTS LIST

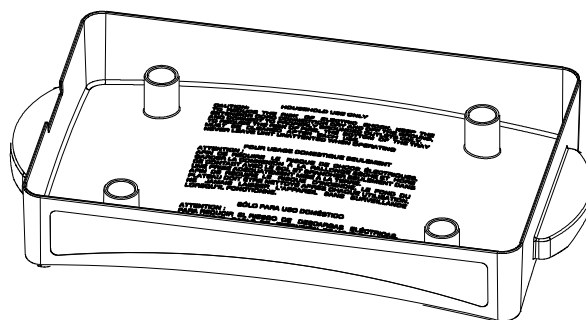
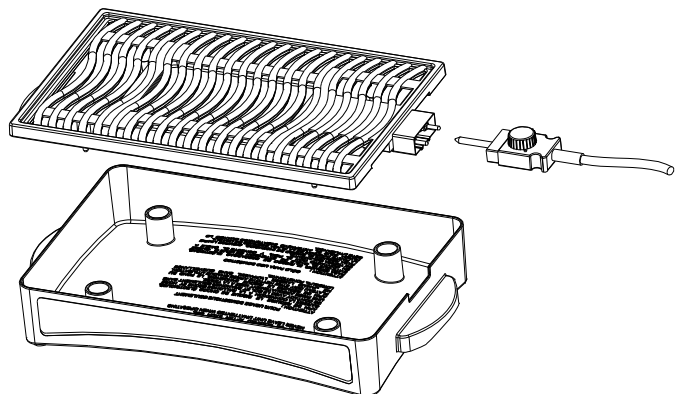

BASE N035-0083

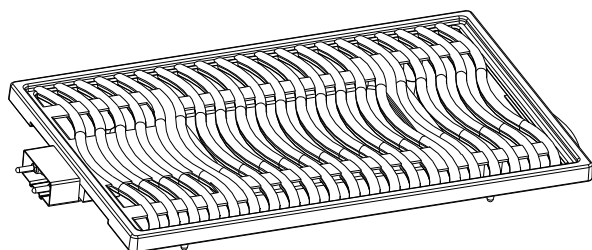

COOKING ELEMENT N305-0061

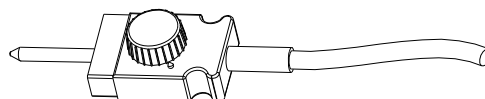

THERMOSTAT N750-0019

ORDERING REPLACEMENT PARTS

Contact the factory directly for replacement parts and warranty claims. The customer care department is available between 9 AM and 5 PM (Eastern Standard Time) at 1-866-820-8686 or fax at 1-705-727-4282. In order to process a claim, we must be provided with the following information:

1. Model number of the unit.
2. Part number and description.
3. A concise description of the problem ('broken' is not sufficient).
4. Proof of purchase (photocopy of the invoice).

In some cases the customer care representative may request to have the parts returned to the factory for inspection, before providing replacement parts. The parts must be shipped prepaid to the attention of the customer care department with the following information:

1. Model number of the unit.
2. A concise description of the problem ('broken' is not sufficient).
3. Proof of purchase (photocopy of the invoice).
4. Return Authorization number - provided by the customer care representative.

Before contacting customer care, please note that the following items are not covered by the warranty:

- costs for transportation, brokerage or export duties
- labor costs for removal and re-installation
- costs for service calls to diagnose problems
- discoloration of stainless steel parts
- part failure due to lack of cleaning and maintenance, or use of improper cleaners (oven cleaner).