

This Owner's Manual is provided and hosted by [Appliance Factory Parts](#).



Napoleon PTH38PGM Owner's Manual

[Shop genuine replacement parts for Napoleon
PTH38PGM](#)



[Find Your Napoleon Patio Heater Parts - Select From 12 Models](#)

----- Manual continues below -----

PROPANE PATIO HEATER

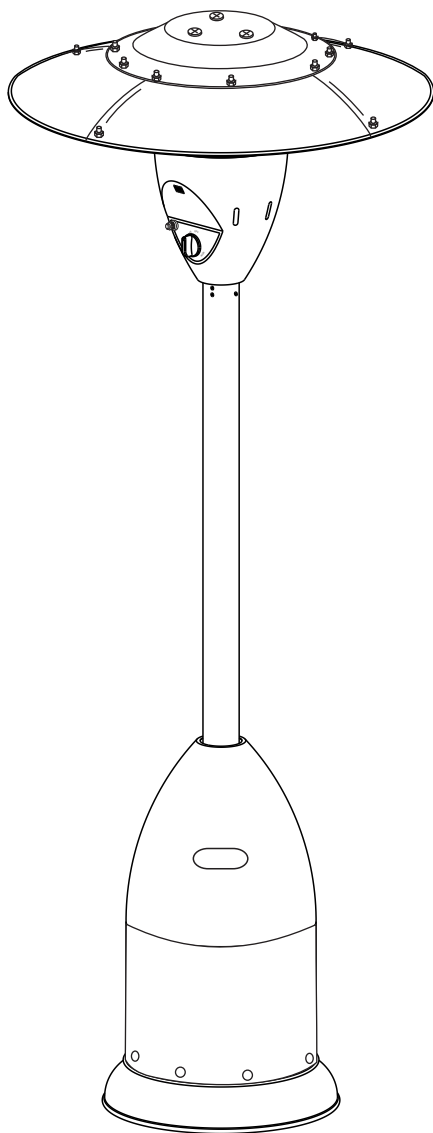

WARNING: For Outdoor Use Only.

FOR YOUR SAFETY

If you smell gas:

1. Shut off gas to the appliance.
2. Extinguish any open flame.
3. If odor continues, immediately call gas supplier.

FOR YOUR SAFETY

Do not store or use gasoline or other flammable vapors or liquids in the vicinity of this or any other appliance.

CAUTION: Retain these instructions for future use.



Model No.: SRPH02S

Master Contract No.: 217109

Customer Item No.: PTH38PSS

PTH38PGM

PTH38PCP

Manual, Instructions & Parts List

TOOLS AND PARTS NEEDED FOR ASSEMBLY



DANGER



CARBON MONOXIDE HAZARD

This appliance can produce carbon monoxide which has no odor.

Using it in an enclosed space can kill you.

Never use this appliance in an enclosed space such as a camper, tent, car or home.

WARNING: Improper installation, adjustment, alteration, services or maintenance can cause injury, death or property damage. Read the installation, operating and maintenance instructions thoroughly before installing or servicing this equipment.

TOOLS NEEDED:

7/16" Wrench
3/8" Open End Wrench
Adjustable Wrench
Philips Head Screwdriver
Leak Detection Solution (Instructions on Page 8)

WARNING

For outdoor use only.

Cylinders to be used must be constructed and marked in accordance with US DOT specifications.

Storage indoors is permissible only if the cylinder is removed.

The unit should be secured or moved indoors if winds exceed 35 km/h.

Note: 20 Pound, 5 Gallon LPG Tank is not supplied

The bill of sale or copy will be required together with the serial and model numbers when making any warranty claims from NAC. Do not return parts to our address without first obtaining a return authorization number. The customer service department is available between 9AM and 5PM (EST).

NAC Customer Care
214 Bayview Drive
Barrie, ON
Canada, L4N 4Y8
1-866-820-8686
1-705-727-4282 (fax)
care@nac.on.ca

PARTS

- ① 1 Center Reflector Cap
- ② 4 Reflector Cap
- ③ 1 Head Assembly
- ④ 1 Gas Hose
- ⑤ 1 Post
- ⑥ 1 Cylinder Cover
- ⑦ 3 Post Mounts
- ⑧ 1 Cylinder Base
- ⑨ 15 M6 Nuts
- ⑩ 18 6mm Washers
- ⑪ 6 5mm Washers
- ⑫ 5 4mm Washers
- ⑬ 5 M4 x8 Bolts
- ⑭ 6 M5 x8 Bolts
- ⑮ 12 M6 x10 Bolts
- ⑯ 3 M6 x70 double pointed bolts
- ⑰ 1 Regulator
- ⑱ 1 Cylinder (Not Supplied)

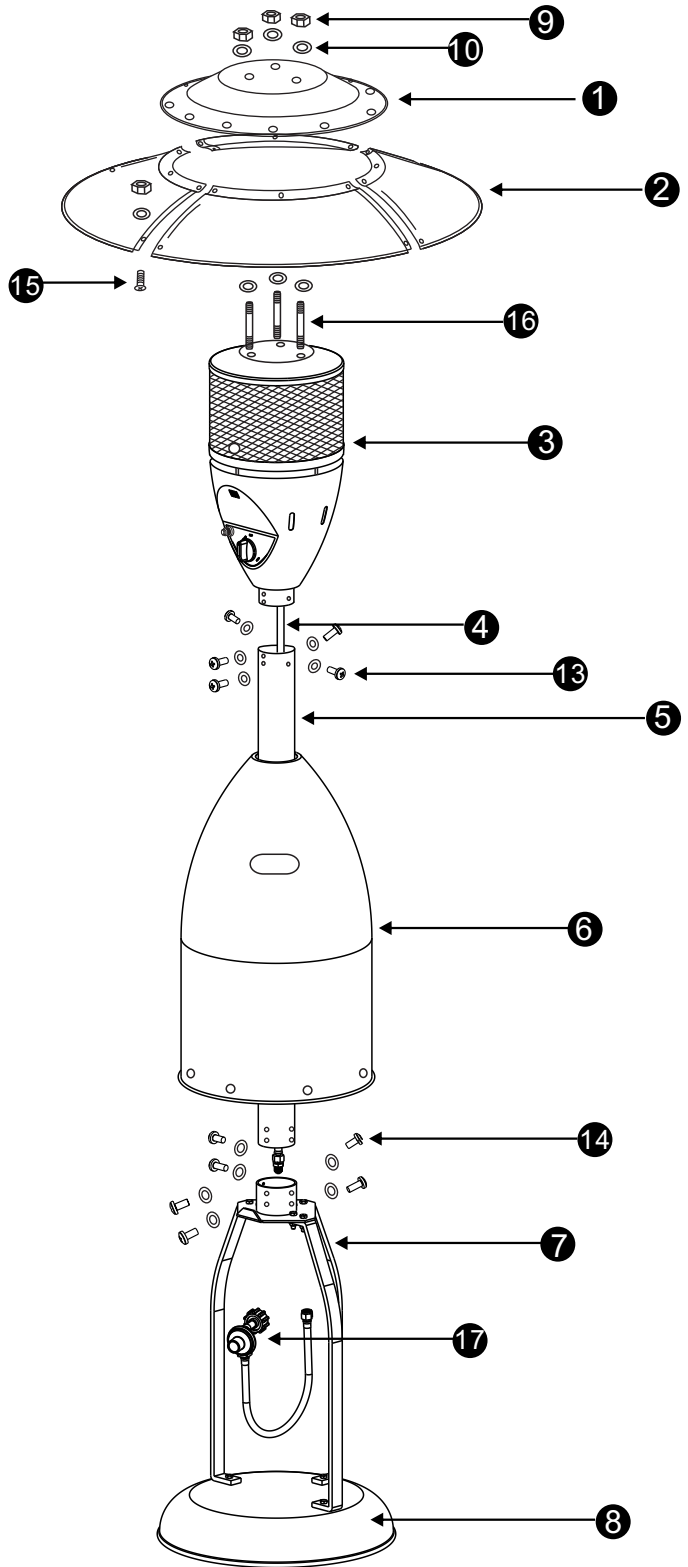
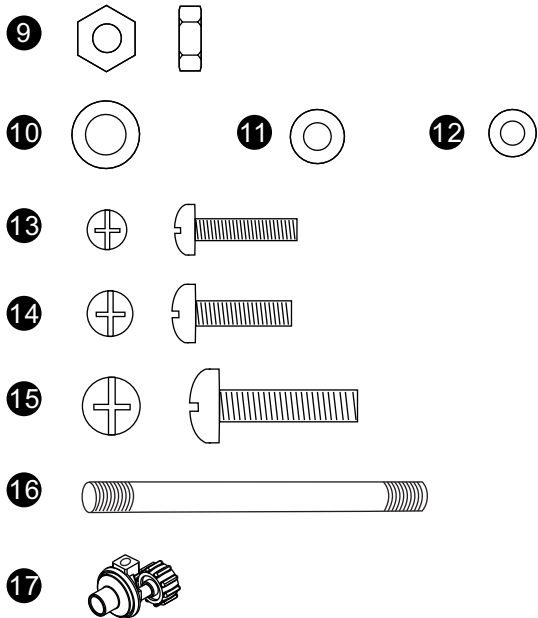

NOTE: PLEASE READ THE FOLLOWING SAFETY RULES

WARNING

This appliance must only be used outdoors. Using this product in an enclosed area may cause injury, death or property damage.

Read the instructions before use. This appliance must be installed in accordance with such regulations as are in force.

Do not use the heater in an explosive atmosphere. Keep the heater away from areas where gasoline or other flammable liquids or vapors are stored.

Prior to use, check for damaged parts such as hoses, regulators, pilot or burner.

The installation of fixed appliances shall only be carried out by competent persons and be in accordance with the relevant Codes of Practice.

Warning: This appliance requires a gas hose and regulator, check with your gas supplier and or product supplier. Regularly check the gas hose and if necessary, replace the gas hose.

DISCONNECT LPG bottle before moving the heater.

Do not attempt to alter unit in any manner.

EXAMPLE: using the heater without the top canopy reflector or radiant screen.

Do not shorten the burner post assembly.

The appliance shall not be used in basements or below ground level.

It must always be placed on a solid and level surface.

For outdoor use ONLY.

Never replace or substitute the regulator with any regulator other than the factory suggested replacement.

Do not clean the heater with cleaners that are combustible or corrosive.

Do not paint radiant screen, control panel or top canopy reflector.

All leak tests should be done with a soapy solution. **NEVER USE AN OPEN FLAME TO CHECK FOR LEAKS.**

The **LP** gas cylinder should be turned off when the heater is not in use.

At least once a year, the unit should be inspected for the presence of spiders, spider webs or other insects. Check the heater immediately if any of the following exist:

1. The smell of gas in conjunction with extreme yellow colored tips of the burner flames.
2. The heater does not reach temperature.
3. The burner makes popping noise during use (a slight popping noise is normal when the burner is extinguished after using).

The propane hose with regulator assembly shall be located out of pathways where people may trip over it or in areas where the hose will not be subject to accidental damage.

Children and adults should be aware of the hazards of high surface temperature.

Young children should be carefully supervised when they are in the area of the heater.

Clothing or other flammable material should not be hung from the heater, or placed on or near the heater.

Any guard or other protective device removed for servicing the heater must be replaced prior to operating the heater.

Installation and repair should be done by a qualified service person. The heater should be inspected before use and cleaning may be required at least once a year, or as necessary. It is imperative that control compartment, burner and circulating air passageways of the heater be kept clean.

Keep the appliance area clear of combustible materials such as gasoline and other flammable vapors and liquids.

Do not obstruct the flow of combustion and ventilation air.

Keep the ventilation opening of the cylinder enclosure free and clear of debris.

IGNITER BATTERY INSTALLATION

Instruction For Battery Installing

Remove igniter button by turning counter clockwise.
Install "AAA" battery with positive terminal up as indicated
in diagram. Replace igniter button.

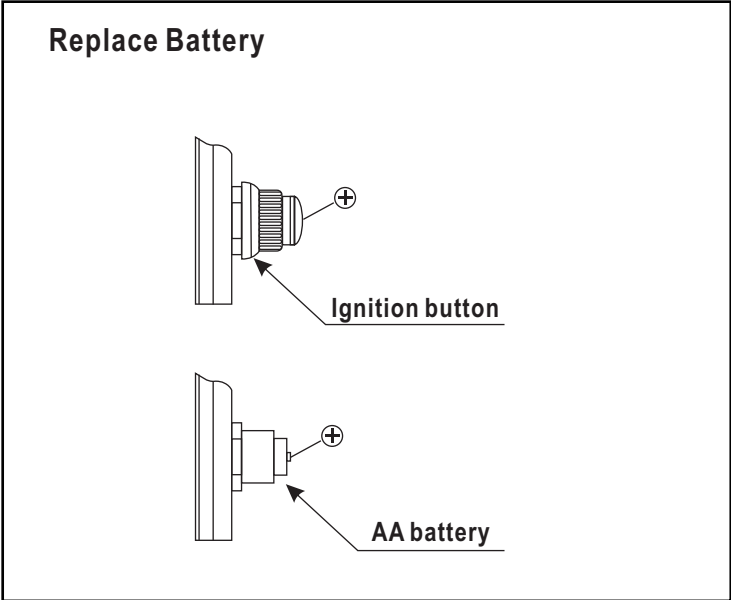
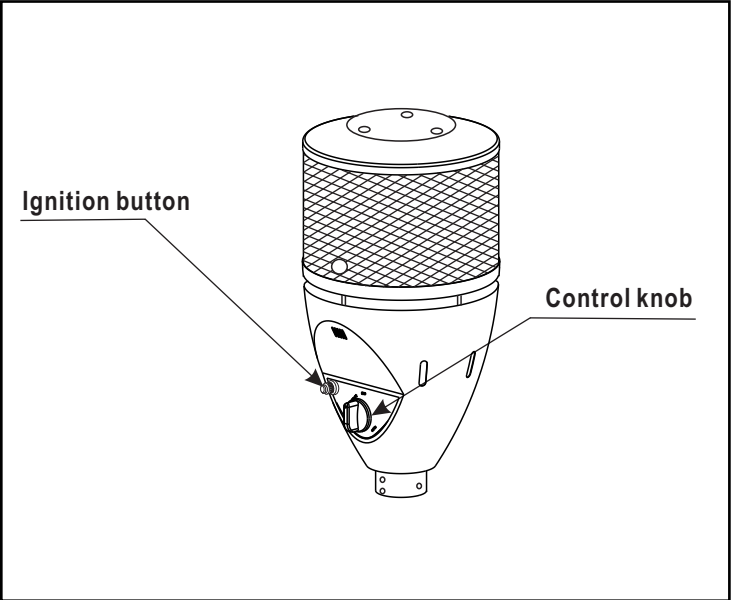

NOTE: Assembly of this heater requires basic mechanical skills. Proper assembly is the responsibility of the installer.

Step 1 ---- Attach Post to Base Assembly

Attach the post to the post mounts using M5 X 8 bolts (6 pcs) and 5mm washers (6 pcs)

Step 1

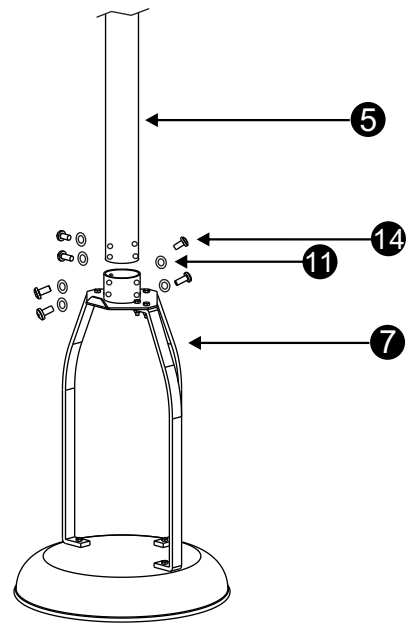

Step 2 ---- Attach Cylinder Cover to Post Mounts

Attach the cylinder cover to the post mounts by sliding over post as indicated.

Step 2

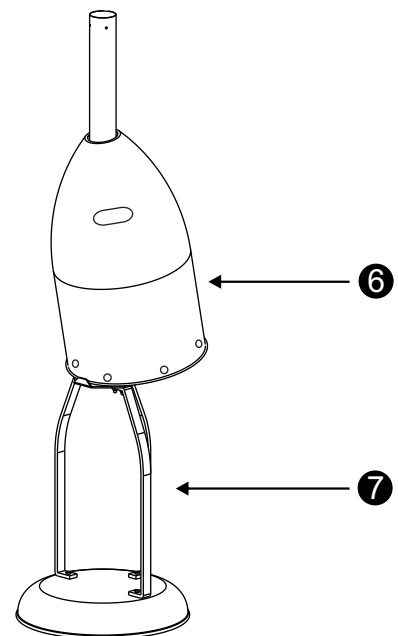

NOTE: Assembly of this heater requires basic mechanical skills. Proper assembly is the responsibility of the installer.

Step 3 ---- Attach Head Assembly to Post

Load head assembly by inserting gas hose into post.

Insert head assembly into post.

Tighten securely using M4 X 8 Bolts (5 pcs) and 4mm washers (5 pcs).

Step 3

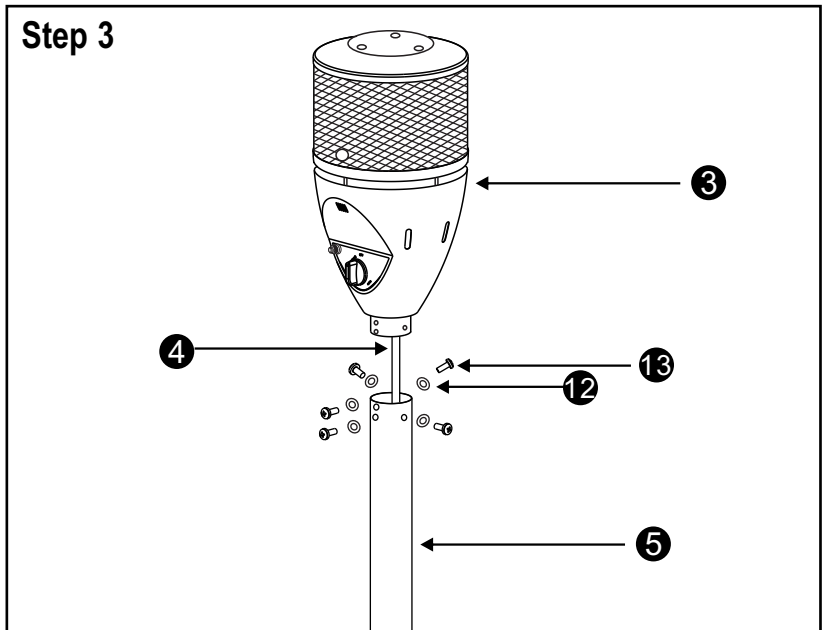

Step4 ---- Attach Double Threaded Bolts to Head Assembly

Attach M6 X 70 double threaded bolts (3 pcs) and 6mm washers (3 pcs) to the top of head assembly and tighten the bolts securely.

Step 4

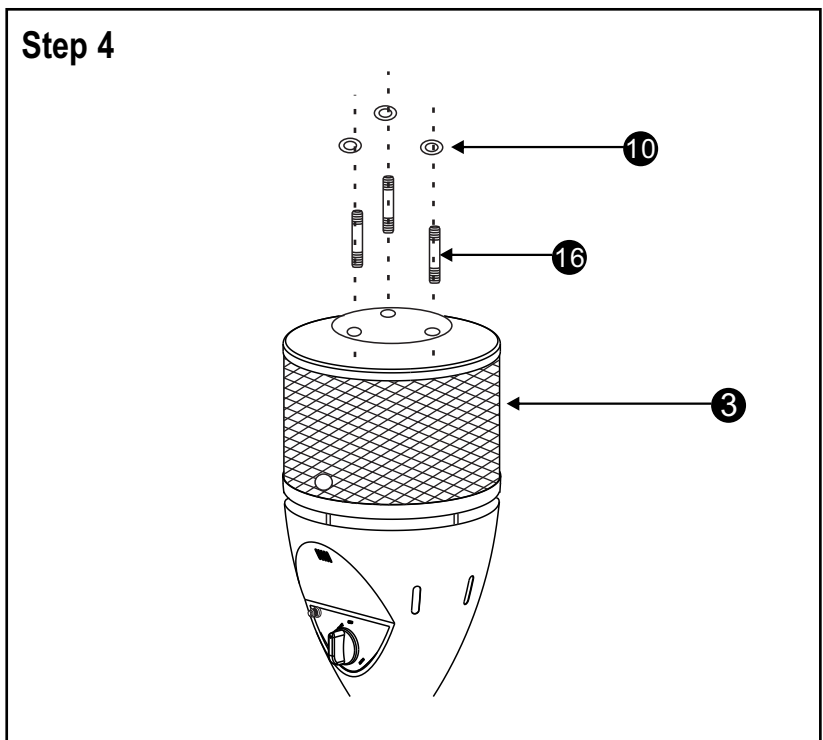

NOTE: Assembly of this heater requires basic mechanical skills. Proper assembly is the responsibility of the installer.

Step 5 ---- Attach Center Reflector to Reflector

Attach center reflector to the top of reflector (4 pcs) with M6 X 10 mm screws (12 pcs), 6mm washers (12 pcs) and nuts (12 pcs).

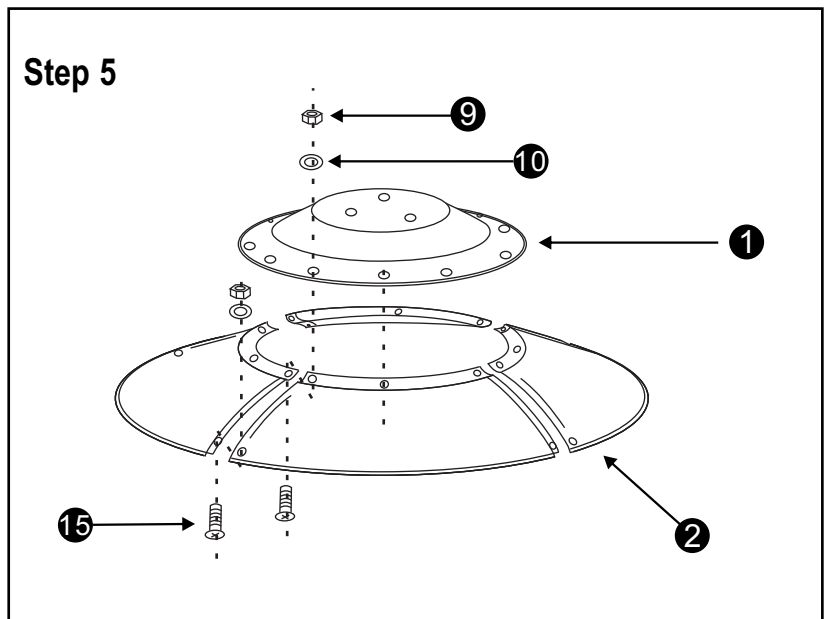

Step 6 ---- Attach Center Reflector and Reflector to the top of Head Assembly

Attach center reflector and reflector to the top of head assembly by sliding over M6 X 70 double threaded bolts (3 pcs). Fasten with 6mm washers (3 pcs) and nuts (3 pcs).

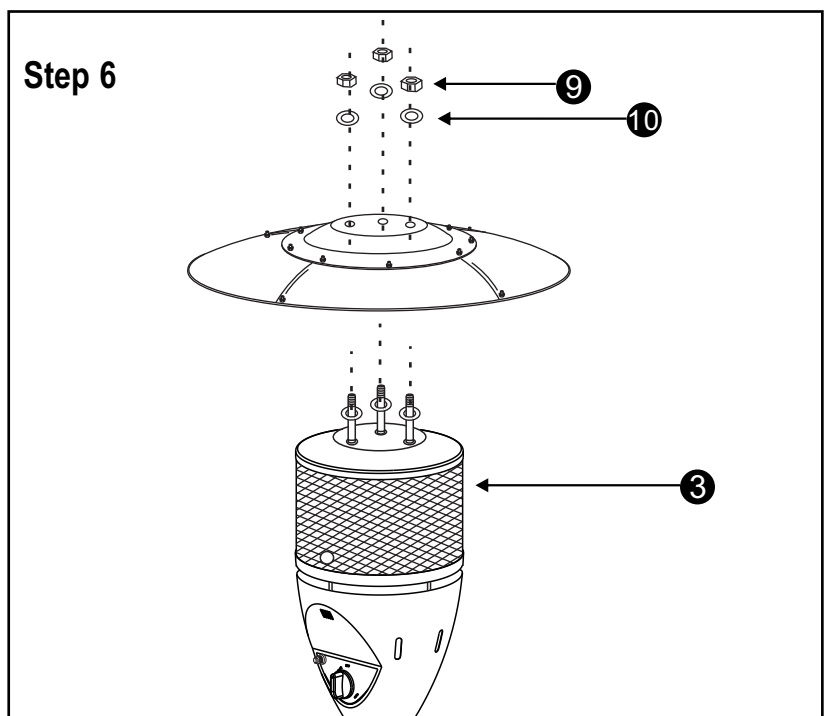

NOTE: Assembly of this heater requires basic mechanical skills. Proper assembly is the responsibility of the installer.

Step 7 ---- Connect Gas Line to Cylinder

Attach Gas hose to regulator with 3/8 inch open end wrench and adjustable wrench. Attach regulator to cylinder. Tighten securely. Move cylinder to the plate of base assembly.

Step 7

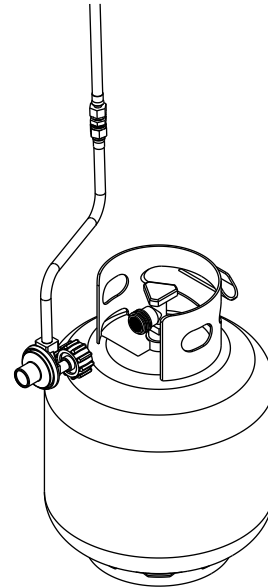

Step 8 ---- Check for leaks

Your Patio Heater has been checked at all factory connections for leaks. To check the connection of the gas hose/regulator/cylinder:

- 1) Make leak solution by mixing 1 part liquid dish soap and 3 parts water.
- 2) Brush several drops (or use spray bottle) of the solution onto the gas hose/regulator and regulator/cylinder connection.
- 3) Turn on gas. Inspect the connections and look for bubbles.
- 4) If no bubbles appear, the connection is safe.
- 5) If bubbles appear, there is a leak, loosen and re-tighten this connection.

Step 8

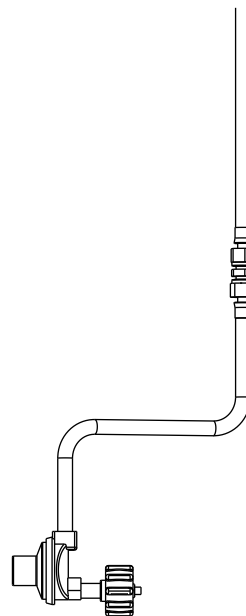

Step 9---- Lower Cylinder Cover onto Cylinder Base

Lower the cylinder cover onto the cylinder base .

Step 9

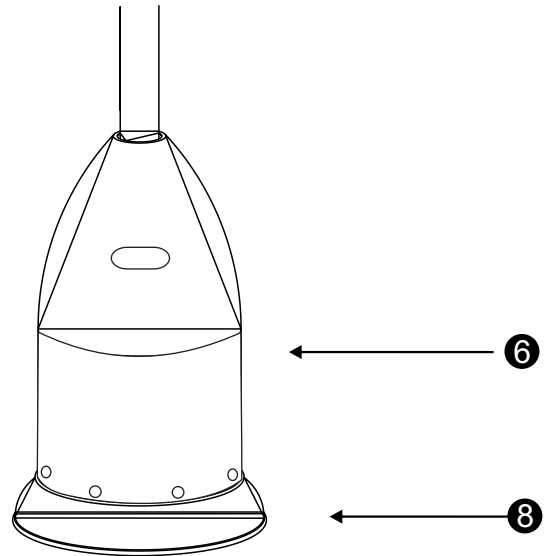

Step 10---- Disconnect Cylinder When Storing or Transporting

- 1) Turn off the heater.
- 2) Raise the cylinder cover onto the post mounts.
- 3) Turn off the valve on the cylinder.
- 4) Disconnect the regulator from the cylinder.

Step 10

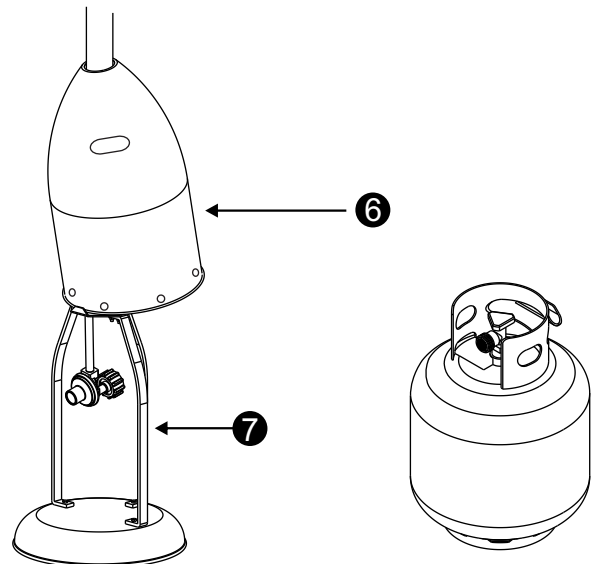

WARNING: DO NOT attempt to operate heater until you have read and understand all precautions. Failure to do so can result in serious personal injury, death or property damage.

Before Turning Gas Supply ON

Your heater was designed and approved for OUTDOOR USE ONLY. DO NOT use it inside a building, or any other enclosed area. Make sure surrounding areas are free of combustible materials, gasoline and other flammable vapors or liquids. Ensure that there is no obstruction to air ventilation. Be sure all gas connections are tight and there are no leaks. Be sure the access panel is clear of debris. Be sure any component removed during assembly or servicing is replaced and fastened prior to starting.

Before Lighting

Heater should be thoroughly inspected before each use, and by a qualified service person at least annually. If relighting, always wait at least 5 minutes.

This heater is tested for quality assurance. Ignition attempts should succeed 8 out of 10 attempts.

LIGHTING INSTRUCTIONS

1. Push and turn the control knob clockwise to the off position.
2. Fully open the propane tank valve or natural gas supply valve.
3. Push and turn the control knob counter-clockwise to the pilot position. Depress the control knob. Push and hold the igniter button until the pilot lights.
4. Once the pilot lights, release the igniter button and continue to depress the control knob for 30 seconds.
5. After depressing the control knob for 30 seconds, release the control knob and turn it counter-clockwise to the low or high position.

Note: If the pilot light will not ignite, turn the control knob to the off position, and fully close the propane tank valve or natural gas supply valve. Wait 5 minutes and then repeat steps 2-4.

Alternately, the pilot can be lit using a wand lighter. Push and turn the control knob to the pilot position. Depress the control knob. Insert the lit lighter through the ignition hole on the emitter screen. Once the pilot lights, remove the lighter and continue to depress the control knob for 30 seconds.

Whenever the unit is disconnected from the natural gas supply, the supply lines fill with air. Expect a delay in lighting the pilot, the first time the unit is lit after reconnecting.

INSTRUCTIONS D'ALLUMAGE

1. Poussez et tournez le bouton de réglage vers la droite à "off".
2. Ouvrez complètement la soupape du réservoir de propane ou de l'approvisionnement en gaz naturel.
3. Poussez et tournez le bouton de réglage vers la gauche à "pilot". Appuyez sur le bouton de réglage. enfoncez et maintenez l'allumeur jusqu'à ce que la veilleuse s'allume.
4. Une fois la veilleuse allumée, relâchez l'allumeur et continuez d'appuyer sur le bouton de réglage pendant 30 secondes.
5. Après avoir appuyé sur le bouton de réglage pendant 30 secondes, relâchez le bouton de réglage et tournez-le vers la gauche à "low" ou à "high".

Remarque : Si la veilleuse ne s'allume pas, tournez le bouton de réglage à "off" et fermez complètement la soupape du réservoir de propane ou de l'approvisionnement en gaz naturel. Attendez 5 minutes et répétez les étapes 2 à 4. Comme autre alternative, la veilleuse peut être allumée à l'aide d'un allumeur. poussez et tournez le bouton de réglage à "pilot". Appuyez sur le bouton de réglage. Insérez l'allumeur allumé dans l'orifice d'allumage sur l'émetteur grillagé. Lorsque la veilleuse s'allume, retirez l'allumeur et continuez d'appuyer sur le bouton de réglage pendant 30 secondes. lorsque l'appareil est débranché du réservoir de propane ou de l'approvisionnement en gaz naturel, les conduites d'alimentation se remplissent d'air. Un délai sera nécessaire pour allumer la veilleuse la première fois que l'appareil sera allumé après avoir été rebranché.

WARNING

FOR YOUR SAFETY:

If at any time you are unable to light burner and smell gas, wait 5 minutes to allow gas to dissipate before attempting to light heater.

If after 1 minute you are unable to light burner, wait 5 minutes and allow flammable vapors to dissipate before attempting to light heater again.

WARNING

FOR YOUR SAFETY:

DO NOT touch or move heater for at least 45 minutes after use.

Allow emitter and dome to cool before touching.

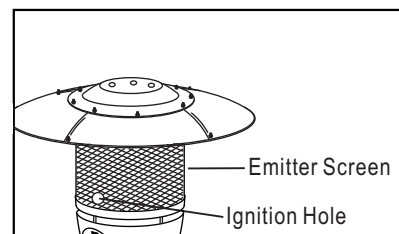
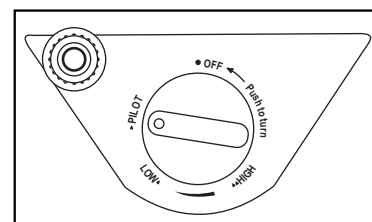
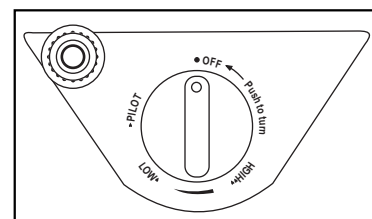

Note: The flame pattern at the emitter grid should be visually checked whenever the heater is operated. Normally the burner flame is blue, but little yellow flame is acceptable. If flames extend beyond the surface of the emitter grid, flame is lifting off the or there is a black soot (carbon) accumulating on the emitter grid or reflector, the heater should be turned off immediately. The heater should not be operated again until services and or replaced.

If you experience any ignition problem, turn off the heater and gas supply, and consult "Troubleshooting" on page 15.

When lit for the first time the heater may emit a slight odor and smoke. This is a normal temporary condition caused by the "burn in" of paints and lubricants used in the manufacturing process and will not occur again. Simply run the heater on "high" for 30 minutes.

The burner may be noisy when initially turned on. To eliminate excessive noise from the burner, turn the Control Knob to the "LOW" position. Then turn the knob to the level of heat desired.

When heater is ON:

Emitter screen will become bright red due to intense heat. The color is more visible at night. Burner will display tongues of blue flame. These flames should not be yellow or produce thick black smoke, indicating an obstruction of airflow through the burners.

Operation Pressure Checked

If the flame is very small, this is because the supply pressure is not enough.

- 1) Turn the control knob to "OFF" position.
- 2) Wait five (5) minutes before attempting to relight pilot.
- 3) Repeat steps beginning with step 3 on page 11.

**Never leave the heater unattended while in use.
Follow the Shut Down Instructions outlined below.**

SHUT DOWN INSTRUCTIONS

- 1) Push in and turn control knob clockwise to "OFF" position.
- 2) Turn off the natural gas supply valve.

Note: After use, some discoloration of the emitter screen is normal.

FERMETURE

- 1) Poussez et tournez le bouton de réglage vers la droite à "OFF"
- 2) Fermez complètement la soupape de réservoir de propane ou de l'approvisionnement en gaz naturel.

Note: After use, some discoloration of the emitter screen is normal.

The Event of Gas Leakage

- 1) Turn the control knob to "OFF" position.
- 2) Wait 5 minutes to allow gas to dissipate.
- 3) If odor continues, immediately call gas supplier.

Handle with extreme care.

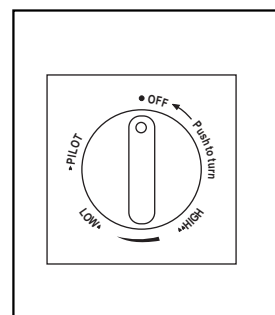
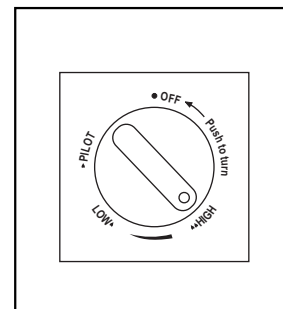

LOCATING HEATER FOR USE

BE CAREFUL: WHEN CERTAIN MATERIALS OR ITEMS ARE STORED, ABOVE, BESIDE OR UNDER THIS HEATER WHILE IN USE, THEY WILL BE SUBJECT TO RADIANT HEAT AND COULD BE SERIOUSLY DAMAGED.

This heater is primarily used for the heating of outdoor patios, decks, pool and spa areas.

Always make sure that adequate fresh air ventilation is provided. Follow the spacing tolerances shown in Figure 1.

The minimum clearances, shown in Figure 1, must be maintained at all times.

The installation must conform to local codes, or in the absence of local codes, with the standard for the storage and handling of liquid petroleum gases, ANSI/NFPA 58-1986, or most recent addition. For Canada, with the current CAN1-B149.

This heater must be placed on firm level ground.

Never operate in an explosive atmosphere. Keep away from areas where gasoline or other flammable liquids or vapors are stored or used.

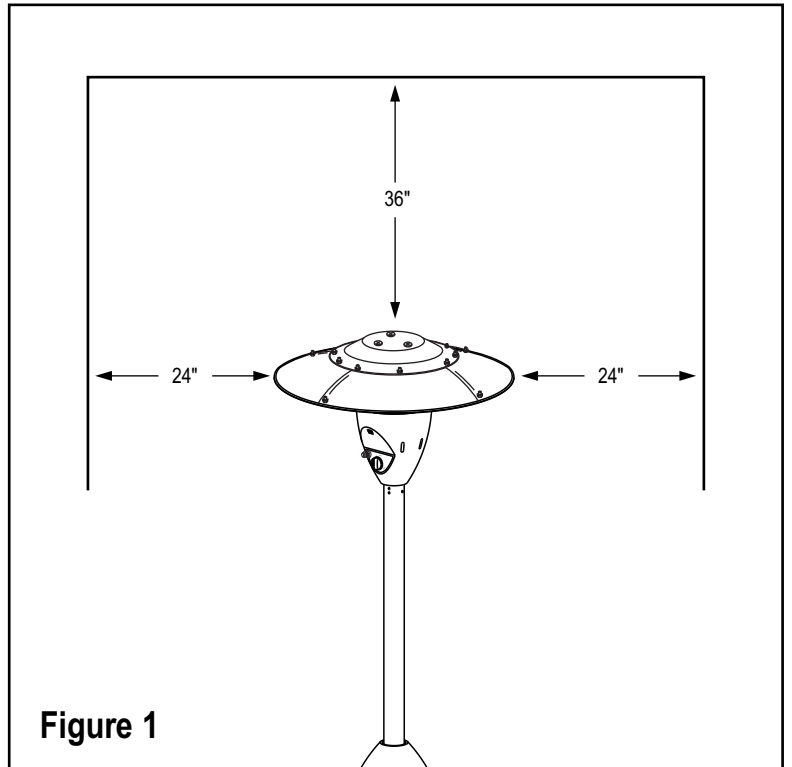

MAINTENANCE/CLEANING/STORAGE

MAINTENANCE :

To enjoy years of outstanding performance from your heater make sure you perform the following maintenance activities on a regular basis:

- Keep exterior surfaces clean.
 - Use warm soapy water for cleaning. Never use flammable or corrosive cleaning agents.
 - While washing your unit, be sure to keep the area around the burner and pilot assembly dry at all times. If the gas control is exposed to water in any way, DO NOT try to use it. It must be replaced.
- Air flow must be unobstructed. Keep controls, burner and circulating air passageways clean. Signs of possible blockage include:
 - Gas odor with extreme yellow tipping of flame.
 - Heater does NOT reach the desired temperature.
 - Heater glow is excessively uneven.
 - Heater makes popping noises.
- Spiders and insects can nest in burner or orifices. This dangerous condition can damage heater and render it unsafe for use. Clean burner holes by using a heavy-duty pipe cleaner. Compressed air may help clear away smaller particles.
- Carbon deposits may create a fire hazard. Clean dome and emitter with warm soapy water if any carbon deposits develop.

CLEANING :

1. Remove the reflector and emitter by removing the 4 screws that fasten the emitter to the lower screen cone . Any debris in the **burner port** should be cleared. Any rust can be removed carefully with a wire brush. Never use a piece of wood, or other materials that might break off and block the ports.
2. Remove lower cone cylinder by removing the 4 screws which attach the lower cone cylinder to the control cylinder. Clear debris on the surface of **thermocouple**.
3. Remove the 4 screws at the bottom of control cylinder. Clear the debris of the surface and the inside of the **injection nozzle**.

NOTE :

It is recommended that the painted components from the emitter down are periodically protected with a coat of automobile wax. If repainting is necessary, paint only the post and gas cylinder housing. Never paint the reflector, head assembly, or instruction plate on post.

Keep exterior surfaces clean:

Use warm soapy water for cleaning. Never use flammable or corrosive cleaning agents. While washing your unit, be sure to keep the area around the combustion assembly dry at all times. If the gas control is exposed to water in any way, DO NOT try to use it. It must be replaced.

Visually check

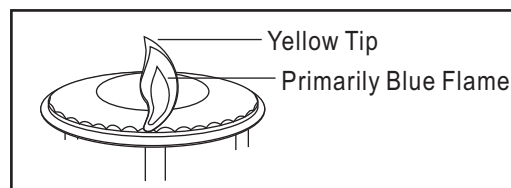
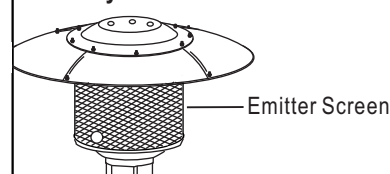

WARNING FOR YOUR SAFETY :

DO NOT touch or move heater for at least 45 minutes after use. Allow all burner elements to cool before touching.

NOTE: In a salt-air environment, such as near an ocean, corrosion occurs more quickly than normal. Frequently check for corroded areas and repair them promptly.

NOTE: Wait until heater is cool before covering.

STORAGE :

Between uses:

- Turn the control knob to "OFF" position.
- Turn LP cylinder to "OFF" position.
- Store heater upright in an area sheltered from direct contact with inclement weather (such as rain, sleet, hail, snow, dust and debris).
- If desired, cover heater to protect exterior surfaces and to help prevent debris in air passages.

During periods of extended inactivity or when transporting:

- Turn the control knob to "OFF" position.
- Disconnect LP Cylinder and move to a secure, well-ventilated location outdoors. **Do NOT** store in a location that will exceed 125 degrees F.
- The propane cylinder must be stored outdoors in well-ventilated area, and it must be out of reach of children, and not in a building, garage or any other enclosed area.
- Store heater upright in an area sheltered from direct contact with inclement weather (such as rain, sleet, hail, snow, dust and debris). If desired, cover heater to protect exterior surfaces and to help prevent debris in air passages.

TROUBLESHOOTING

PROBLEM	PROBABLE CAUSE	SOLUTION
Pilot will not light	Gas valve may be OFF	Turn the gas valve ON
	Fuel Tank empty	Refill LP gas tank
	Orifice blocked	Clean or replace orifice
	Air in supply system	Purge air from lines, with knob in pilot position, depress and hold in, to release air.
	Loose connection	Check all fittings
	Dead battery	Replace battery
Pilot will not stay on	Debris around pilot	Clean dirty area
	Loose connection	Tighten connection
	Thermocouple bad	Replace thermocouple
	Gas leak in line	Check connections
	Lack of fuel pressure	Fuel tank is near empty
Burner will not light	Pressure is low	Supply pressure is not enough
	Orifice blocked	Remove, clean and replace
	Control valve not ON	Turn valve to ON
	Thermocouple is bad	Replace thermocouple
	Pilot light assembly bent or not in correct location	Place pilot in proper position and retry