

This Owner's Manual is provided and hosted by [Appliance Factory Parts](#).

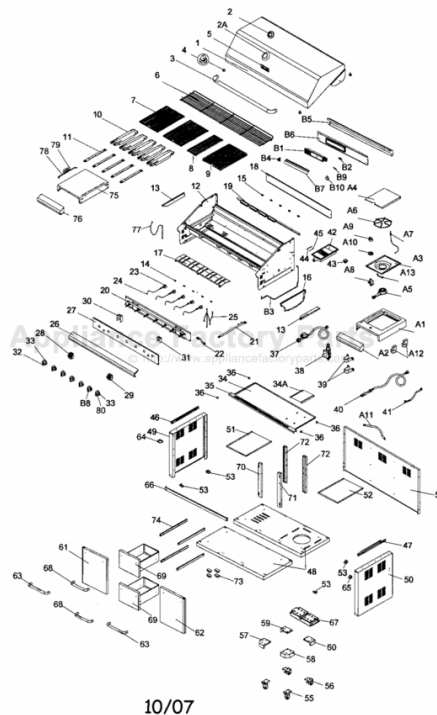

Kenmore 141.17678800 Owner's Manual

[Shop genuine replacement parts for Kenmore
141.17678800](#)



[Find Your Kenmore Grill Parts - Select From 1424 Models](#)

----- Manual continues below -----

Use and Care Guide



Liquid Propane Gas (LPG) Grill

Model 141.16678

Natural Gas (NG) Grill

Model 141.17678

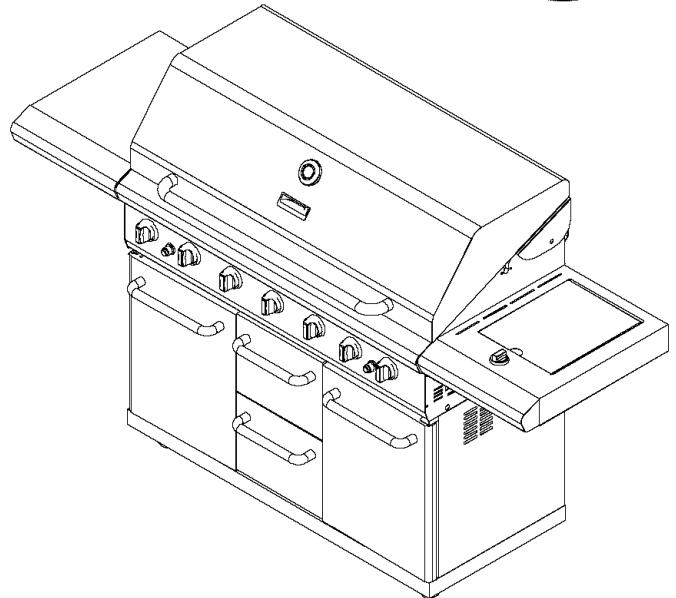

- Safety
- Assembly
- Use and Care
- Cooking Guide
- Frequently Asked Questions

Grill Information Center:

Call us first if you have any problem with this product. We can help you with questions about assembly and grill operation or if there are damaged or missing parts when you unpack this unit from the shipping box. Please call before contacting your local retailer.

1-888-317-7642

8am-8pm CST, Monday through Friday

IMPORTANT:

- **NOTE TO ASSEMBLER/INSTALLER:**
Leave this manual with the consumer.
- **NOTE TO CONSUMER:**
Keep this manual for future reference.
- **RECORD YOUR SERIAL #**

(see silver CSA label on main body of grill)



WARNING



- Failure to comply with these instructions could result in a fire or explosion that could cause serious bodily injury, death or property damage.
- Whether this grill was assembled by you or someone else, you must read this entire manual before using your grill to ensure the grill is properly assembled, installed and maintained.
- **Use your grill at least 3 feet away from any wall or surface.** Use your grill at least **3 feet away** from combustible objects that can melt or catch fire such as vinyl or wood siding, fences and overhangs or sources of ignition including pilot lights on water heaters and live electrical appliances.
- THIS GAS APPLIANCE IS DESIGNED FOR OUTDOOR USE ONLY.
- Combustion byproducts produced when using this product contain chemicals known to the State of California to cause cancer, birth defects, or other reproductive harm.
- Brass components on the grill, such as hose fittings, propane cylinder valves (sold separately) and burner valve stems, contain lead which is known to the State of California to cause cancer, birth defects, or other reproductive harm.

Manual # P80106007H - Date: 2007/09/13

Table of Contents

Primary Safety Warnings	1-3
Warranty Terms and Conditions	2
Pre-Assembly Instructions	3
Part Diagrams and Lists	4-9
Assembly Instructions.....	10-11
LP Gas Tank Installation.....	12-14
Natural Gas Connection.....	15
Use & Care Instructions:	
• Lighting Instructions	16
• Troubleshooting	17
• Rotisserie Instruction	18-20
• Cleaning and Maintenance	21-22
• Cooking Guide	A1-A6
• Frequently Asked Questions.....	A7-A8
• Repair Protection Agreement	A9

Warranty

Kenmore Elite Full Warranty

If this grill fails due to a defect in material or workmanship within one year from the date of purchase, call 1-800-4-MY-HOME® to arrange for free repair (or replacement if repair proves impossible).

Limited Warranty on Stainless Steel Burners

Any stainless steel burner that ever rusts through will be replaced free of charge. After the first year from the date of purchase you must pay the labor cost if you wish to have it installed.

Limited Warranty on Selected Grill Parts

From the date of purchase for the time periods listed below, the following specific grill parts will be replaced free of charge if they rust through. After the first year from the date of purchase you must pay the labor cost if you wish to have them installed.

- Stainless Steel Parts 10 Years (except Burners, see above)
- Painted Steel Parts 3 Years
- Cooking Grids 2 Years
- Heat Diffusers 2 Years

All warranty coverage excludes ignitor batteries and grill part paint loss (except as specified above) or rusting (except for rust-through a specified above), which are either expendable parts that can wear out from normal use in less than a year, or are conditions that can be the result of normal use, accident or improper maintenance.

All warranty coverage is void if this grill is ever used for commercial or rental purposes.

All warranty coverage applies only if this grill is used in the United States.

This warranty gives you specific legal rights, and you may have other rights which vary from state to state.

Sears, Roebuck and Co., Hoffman Estates, IL

© Sears Brands, LLC



DANGER



IF YOU SMELL GAS:

1. Shut off gas to the appliance.
2. Extinguish any open flame.
3. Open lid.
4. If odor continues, keep away from the appliance and immediately call your gas supplier or your fire department.

Leaking gas may cause a fire or explosion which could result in property damage, personal injury or death.



WARNING



1. Do not store spare LP cylinder within 10 feet (3m) of this appliance.
2. Do not store or use gasoline or other flammable liquids and vapors within 25 feet (8m) of this appliance.
3. When cooking with oil/grease, do not allow the oil/grease to get hotter than 350°F (177°C).
4. Do not leave oil/grease unattended.



WARNING



The Grease Draining Tray and Grease Receptacle must be visually inspected before each grill use. Remove any grease and wash Grease Draining Tray and Grease Receptacle with a mild soap and warm water solution. **Failure to comply with these instructions could result in a grease fire or explosion that could cause serious bodily injury, death or property damage.**



WARNING



Never use charcoal or lighter fluid in this gas grill. Failure to comply with these instructions could result in a grease fire or explosion that could cause serious bodily injury, death or property damage.

Pre-Assembly Instructions For Your Safety



WARNING



Failure to comply with these instructions could result in a fire or explosion that could cause serious bodily injury, death or property damage.

Spiders and small insects can spin webs and nest in the grill Burner Tubes during transit and warehousing which can lead to a gas flow obstruction resulting in a fire in and around the Burner Tubes. This type of "FLASHBACK FIRE" can cause serious grill damage and create an unsafe operating condition for the user.

To reduce the chance of FLASHBACK FIRE you must clean the Burner Tubes as follows before initial use. Also do this at least once a month in summer and fall or whenever spiders are active in your area, and if your grill has not been used for an extended period of time.

1. Remove the screw from the rear of each Burner using a Phillips Head Screwdriver.
2. Carefully lift each Burner up and away from the Gas Valve Orifice.
3. Check and clean Burner/Venturi Tubes for insects and insect nests. A clogged tube can lead to a fire beneath the grill.
4. Refer to the figure below and perform one of these 3 cleaning methods:

- METHOD 1: Bend a stiff wire or wire coat hanger into a small hook as shown and run the hook through the Burner Tube and inside the Burner several times to remove debris.

TO CLEAN BURNER TUBE,
INSERT HOOK HERE

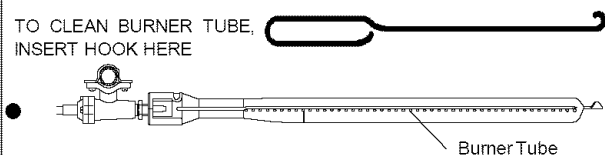

- METHOD 2: Use a bottle brush with a flexible handle and run the brush through the Burner Tube and inside the Burner several times to remove any debris.

- METHOD 3: Use an air hose to force air through each Burner Tube. The forced air should pass debris or obstructions through the Burner and out the Ports.

For safe operation ensure the Gas Valve Assembly Orifice is inside the Burner Tube before using your grill. See figure. If the Orifice is not inside the Burner Tube, lighting the Burner may cause explosion and/or fire resulting in serious bodily injury and/or property damage.

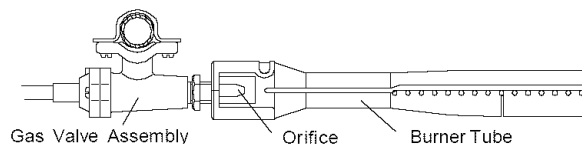

Grill Installation Codes

The installation must conform with local codes or, in the absence of local codes, with either the National Fuel Gas Code, ANSI Z223.1/NFPA 54, Natural Gas and Propane Installation Code, CSA B149.1, or Propane Storage and Handling Code, B149.2.



WARNING



- LPG grill models must be used with Liquid Propane Gas and the regulator assembly supplied. Natural Gas models must be used with Natural Gas only. Any attempt to convert the grill from one fuel type to another is extremely hazardous and will void the warranty.
- **Never** use your gas grill in a garage, porch, shed, breezeway or any other enclosed area.
- **Never** obstruct the flow of ventilation air around your gas grill housing.
- **Never** disconnect the gas regulator or any gas fitting while your grill is lit. A lit grill can ignite leaking gas and cause a fire or explosion which could result in property damage, personal injury or death.
- Keep gas regulator hose away from hot grill surfaces and dripping grease. Avoid unnecessary twisting of hose. Visually inspect hose prior to each use for cuts, cracks, excessive wear or other damage. If the hose appears damaged do not use the gas grill. Call Sears at 1-800-4-MY-HOME® (1-800-469-4663) for a Sears replacement hose.

PRE-ASSEMBLY

Read and perform the following pre-assembly instructions:

- Tools Required for Assembly** include:
- protective work gloves
 - protective eyewear
 - #3 Phillips Head Screwdriver
- You will need assistance from another person to handle the large, heavy parts.
- Open Lid of shipping carton and remove parts box and packing materials. Lay cardboard sheet on floor and use as a work surface to protect floor and grill parts from scratches.
- Slice all four corners with a utility knife to lay open the carton. This allows you to remove the components packed inside.
- Use the Hardware and Part Diagrams to ensure all items are included and free of damage.
- Do not assemble or operate the grill if it appears damaged. If there are damaged or missing parts when you unpack the shipping box or you have questions during the assembly process, call the:

Grill Information Center 1-888-317-7642
8am-8pm CST, Monday through Friday

Hardware Pack Parts List for 141.16678 & 141.17678

PART #	PART DESCRIPTION	QTY	PURPOSE OF PART
P06001062A	Hardware Pack	1	For use in assembly of Model 16678-17678
S112G0408E	Phillips Head Screw 1/4"x1/2"	7	Attaches Side Shelf Left to Bowl Side Panel
S313G04081	Flange Nut 1/4"	2	
S112G0408E	Phillips Head Screw 1/4"x1/2"	7	Attaches Side Burner Frame to Bowl Side Panel
S313G04081	Flange Nut 1/4"	2	
S112G0306E	Phillips Head Screw 3/16"x3/8"	2	Attaches Decorative Panel to Bowl Side Panel
Already Installed on the Cart Rear and Right Cart Side Panel			
P055360014	Hose Holder (LPG Only)	2	Attaches Regulator with Hose to Cart Rear Panel and Right Cart Side Panel
P055360014	Hose Holder (NG Only)	1	Attaches Extension Hose to Right Cart Side Panel
Already installed on the Cart Bottom Shelf			
S233G05461	Wing Bolt 5/16"x4-1/2"	1	Secures Gas Tank
S303G0504D	Special Nut 5/16"	1	
Already installed on the Tool Holder			
S313G04081	Flange Nut 1/4"	2	Attaches Tool Holder to Left Side Shelf

Hardware Pack Diagram for 141.16678 & 141.17678

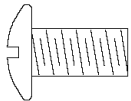

Phillips Head Screw
1/4" x 1/2"
Qty. 14
Part# S112G0408E

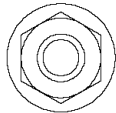

Flange Nut 1/4"
Qty. 4
Part# S313G04081

Already installed on the Cart Rear and Right Side Panel

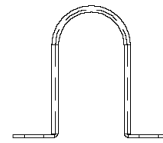

Hose Holder
Qty. 2 (Model 16678)
Qty. 1 (Model 17678)
Part # P055360014
Scale 1:2

Already installed on the Cart Bottom Shelf



Wing Bolt 5/16"x4-1/2"
Qty. 1
Part. # S233G05461
Scale 1:2



Special Nut 5/16"
Qty. 1
Part. # S303G0504D
Scale 1:2



Phillips Head Screw 3/16"x3/8"
Qty. 2
Part # S112G0306E

Already installed on the Tool Holder

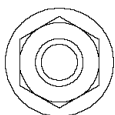

Flange Nut 1/4"
Qty. 2
Part# S313G04081

* Two Battery/AA included in the Hardware Pack.

Parts Diagram for Models 141.16678 & 141.17678

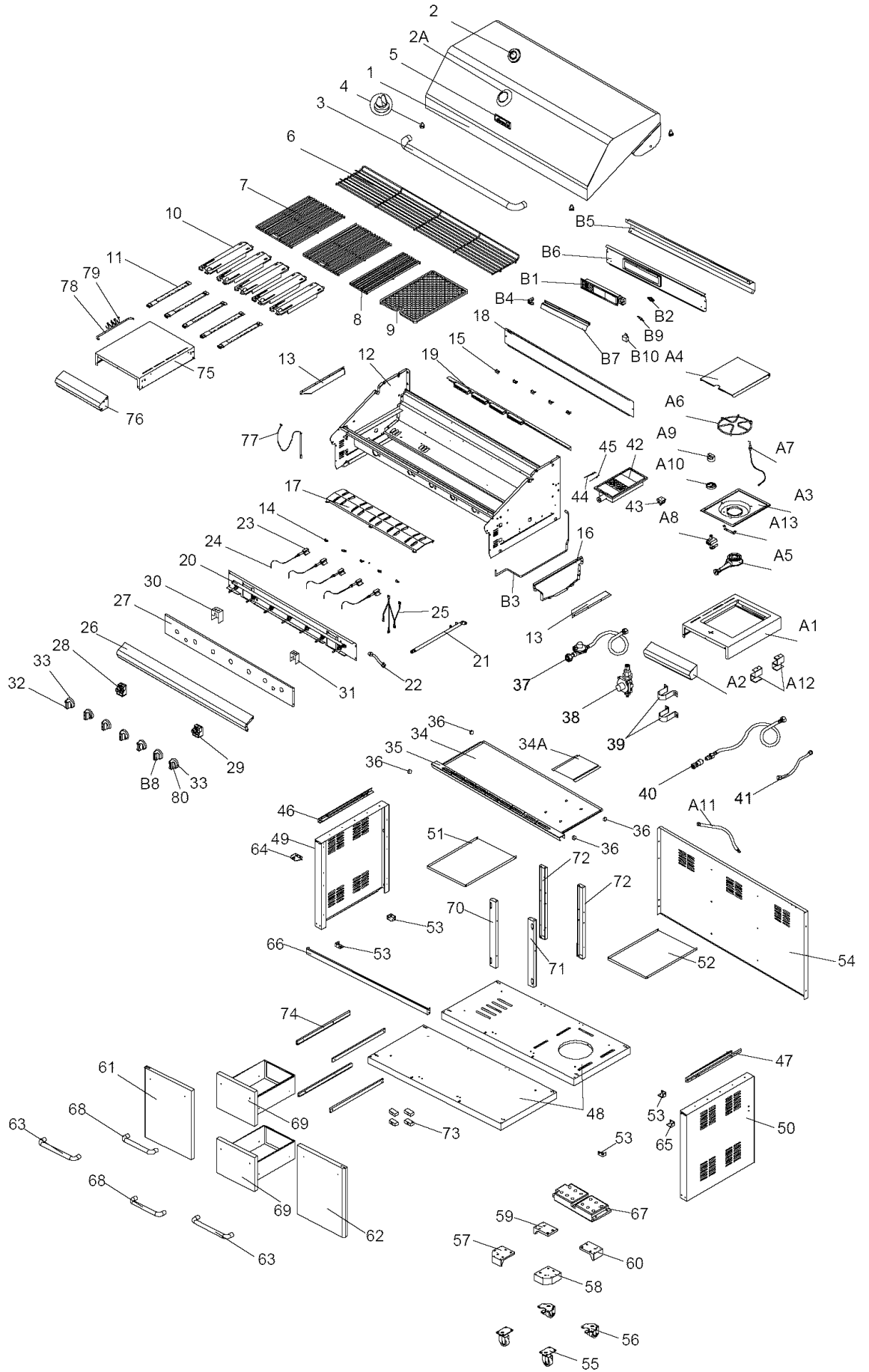

Parts Diagram for Models 141.16678 & 141.17678

KEY	DESCRIPTION	PART #	QTY
1	Lid	P0014707M4	1
2	Temperature Gauge	P00601287C	1
2A	Temperature Gauge Seat	P00614027C	1
3	Lid Handle	P00205068M	1
4	Protective Pad	P05518002I	4
5	Name Plate	P00410039C	1
6	Cooking Rack/Secondary	P01518004G	1
7	Cooking Grid 13"	P016040135	2
8	Cooking Grid 6.5"	P016040105	1
9	Cooking Grid/Infrared Burner	P01615030F	1
10	Heat Diffuser	P017080074	5
11	Burner/Main	P020080324	5
12	Grill Bowl	P0071333E4	1
13	Grease Draining Plate	P069020174	2
14	Heat Diffuser Bracket, Front	P033280154	5
15	Heat Diffuser Bracket, Rear	P033280174	5
16	Burner Heat Shield	P069060344	1
17	Grease Tray Heat Shield	P069010164	1
18	Wind Shield, Rear	P069040444	1
19	Burner Bracket	P0220509G4	1
20	Gas Valve/Manifold Assembly (LPG Only)	Y0060410	1
	Gas Valve/Manifold Assembly (NG Only)	Y0060411	1
21	Gas Manifold	P03708002C	1
22	Gas Manifold Connector	P03715006D	1
23	Gas Collector Box with Electrode	P02609009M	5
24	Electric Wire Set	P02615101A	1
25	Electric Wire, 5-contact	P02615102A	1
26	Control Panel, Upper	P0291182FS	1
27	Control Panel	P0291183ES	1
28	Electric Ignitor, 5-port	P02502298C	1
29	Electric Ignitor, 2-port	P02502282C	1
30	Electric Ignitor Protector, 5-port	P03343007A	1
31	Electric Ignitor Protector, 2-port	P03343006A	1
32	Control Knob For Main Burner	P03426313J	5
33	Control Knob Seat	P03413011J	7
34	Grease Tray (LPG Only)	P02717234A	1
	Grease Tray (NG Only)	P02717244A	1
34A	Grease Tray Heat Shield, Lower (LPG Only)	P06901017C	1
35	Grease Tray Handle	P0272003H4	1
36	Wheel for Grease Tray	P05354002A	4
37	Regulator With Hose (LPG Only)	P03601039A	1
38	Regulator (NG Only)	P03628001B	1
39	Hose Holder (LPG Only)	P055360014	2
	Hose Holder (NG Only)	P055360014	1
40	Hose, 12 ft. (NG Only) 1/2" ID	P03704001A	1
41	Extension Hose (NG only)	P03718002L	1
42	Infrared Burner Assembly	P020050104	1
43	Thermocouple Bracket	P033270354	1
44	Infrared Burner Electrode	P02618007M	1
45	Infrared Burner Thermocouple	P05305018A	1
46	Bowl Support Bracket, Left	P01301010K	1

Parts Diagram for Models 141.16678 & 141.17678

KEY	DESCRIPTION	PART #	QTY
47	Bowl Support Bracket, Right	P01302010K	1
48	Cart Bottom Shelf (LPG Only)	P010200024	1
	Cart Bottom Shelf (NG Only)	P010200034	1
49	Cart Side Panel, Left	P076140104	1
50	Cart Side Panel, Right	P076150214	1
51	Cart Partition Panel, Left	P07512008N	1
52	Cart Partition Panel, Right (NG Only)	P07512009N	1
53	Cart Bottom Panel Bracket	P033280244	4
54	Cart Rear Panel	P077010704	1
55	Caster 2-1/2 in.	P05117010A	2
56	Caster 2-1/2 in., with Brake	P05110007A	2
57	Caster Seat, LF	P05327009Q	1
58	Caster Seat, RF	P05327011Q	1
59	Caster Seat, LR	P05327010Q	1
60	Caster Seat, RR	P05327012Q	1
61	Door, Left	P04302040L	1
62	Door, Right	P04303040L	1
63	Door Handle	P00205073M	2
64	Door Hinge Bracket, Upper Left	P033140414	1
65	Door Hinge Bracket, Upper Right	P033140494	1
66	Cart Bracket	P033060284	1
67	Weight	P05344004Q	1
68	Handle/Drawer	P00212003M	2
69	Drawer	Y0420010	2
70	Cart Partition Panel Bracket, Front Left	P01907010I	1
71	Cart Partition Panel Bracket, Front Right	P01907009B	1
72	Cart Partition Panel Bracket, Rear	P01907011I	2
73	Door Magnet	P05523005M	4
74	Drawer Slide Set	P01907006B	4
75	Side Shelf, Left	P01106009S	1
76	Decorative Panel for Side Shelf	P07503007P	1
77	Lighting Stick	P05313012E	1
78	Tool Holder	P05209004F	1
79	Tool Hooks	P055141314	4
80	Control Knob For Infrared Burner	P03428073H	1
A1	Side Burner Frame	P01108013S	1
A2	Decorative Panel for Side Burner Frame	P07502017P	1
A3	Side Burner Body	P023010194	1
A4	Side Burner Lid	P01127007S	1
A5	Side Burner with Brass Ring (LP Only)	P02002007A	1
	Side Burner with Brass Ring (NG Only)	P02002014A	1
A6	Side Burner Pot Support	P008050104	1
A7	Side Burner Electrode	P02614014C	1
A8	Side Burner Gas Valve (LPG)	Y0060399	1
	Side Burner Gas Valve (NG)	Y0060490	1
A9	Side Burner Control Knob	P03401373H	1
A10	Side Burner Control Knob Seat	P03408053J	1
A11	Side Burner Connection Hose, Plug	P03705051I	1
A12	Side Burner Connection Hose, Bracket	P03341001Q	2
A13	Side Burner Bracket	P033270374	1

Parts Diagram for Models 141.16678 & 141.17678

KEY	DESCRIPTION	PART #	QTY
B1	Rotisserie Burner Assembly	P02007067A	1
B2	Rotisserie Burner Orifice (LPG Only)	P06527003A	1
	Rotisserie Burner Orifice (NG Only)	P06527004A	1
B3	Rotisserie Burner Extension Tube	P03717044B	1
B4	Rotisserie Burner Electrode Assembly	P02610005B	1
B5	Rotisserie Burner Wind Shield	P069060724	1
B6	Rotisserie Burner Frame	P020070154	1
B7	Rotisserie Burner Wind Shield, Front	P069050504	1
B8	Control Knob for Rotisserie Burner	P03411443J	1
B9	Rotisserie Burner Thermocouple	P05305021A	1
B10	Rotisserie Burner Thermocouple Bracket	P033280474	1
	Rotisserie Assembly	Y0250142	1
	Hardware Pack	P06001062A	1
	Use and Care Guide	P80106007H	1

For the repair or replacement parts you need:

Call anytime **1-800-4-MY-HOME®** (1-800-469-4663)

To obtain the correct replacement parts for your gas grill, please refer to the part numbers in this parts list. The following information is required to ensure you receive the correct parts:

1. Model and Serial Number (see CSA label on grill)
2. Part Number
3. Part Description
4. Quantity of parts needed

Important: Use only Sears replacement parts. The use of any part that is not a Sears replacement part can be dangerous and will also void your product warranty. Keep this Use and Care Guide for convenient referral and for part replacement.

Y0250142 Rotisserie Assembly Parts Diagram

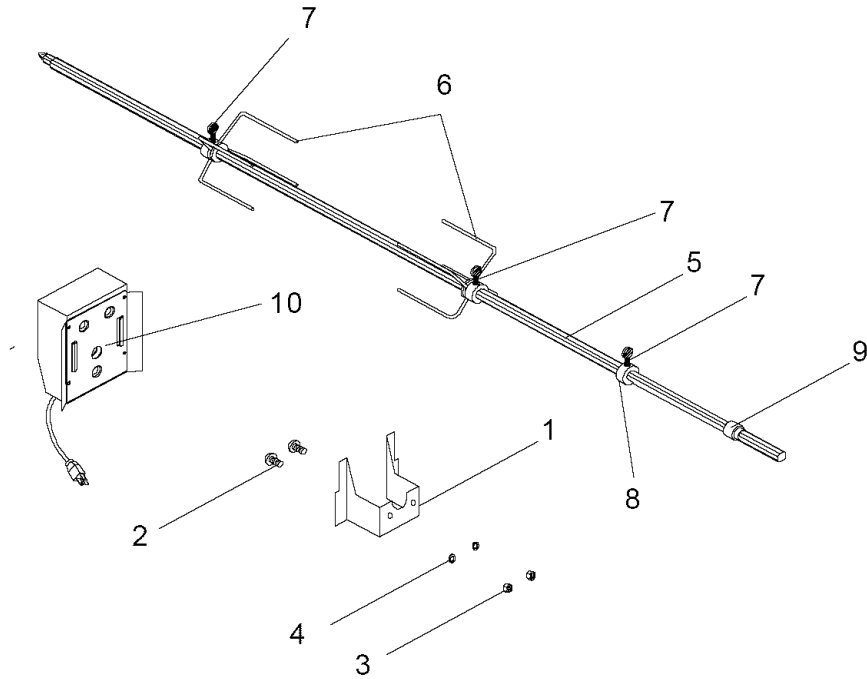

Y0250142 Rotisserie Assembly Parts List

KEY	PARTS DESCRIPTION	PART #	QTY
1	Rot. Motor Bracket	P03307003G	1
2	Rot. Screw #10-24x3/4" UNC	S112G10124	2
3	Rot. Hex Nut #10-24	S362G10124	2
4	Rot. Washer 3/16"	S411G03084	2
5	Rot. Spit	P05508170F	1
6	Rot. Holding Fork	P05508169F	2
7	Rot. Thumbscrew 3/8"x1/2"	S196G06084	3
8	Rot. Collar	P05508168F	1
9	Rot. Bushing	P05508167F	1
10	Rot. Motor/AC	P07101025A	1

Hardware for Rotisserie Y0250142

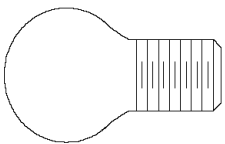

Rot. Thumbscrew
3/8"x1/2"
Qty. 3
Part# S196G06084

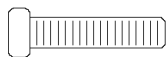

Rot. Screw#10-24x3/4"
UNC
Qty. 2
Part# S112G10124

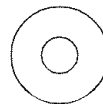

Rot. Washer 3/16"
Qty. 2
Part# S411G03084



Rot. Hex Nut#10-24
Qty. 2
Part# S362G10124

Grill Information Center: If you have questions about assembly or grill operation, or if there are damaged or missing parts when you unpack this unit from the shipping box, call us 8:00 am - 8 pm CST, Monday through Friday at: **1-888-317-7642**

Assembly Instructions

1 Install Left Side Shelf and Right Side Burner Frame

- Place the Side Shelf over the Left Side Shelf Brackets and Side Burner Frame over the Right Side Shelf Brackets.
- Tighten securely by using Screws and Nuts provided.
- Secure Decorative Panel to Bowl Side Panel using Phillips Head Screw 3/16"x3/8".
- Remove 2 Flange Nuts from the Tool Holder. Slide the 4 Tool Hooks onto the Tool Holder with the hooks facing the Left Side Shelf. Attach Tool Holder to Side Shelf using these Flange Nuts.
- From the front of the grill, slide the assembled Tray side tabs over the side rails underneath the Grill Bowl.

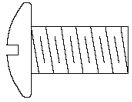

Phillips Head Screw
1/4" x 1/2"
Qty. 14
Part# S112G0408E

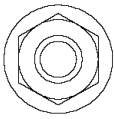

Flange Nut 1/4"
Qty. 4
Part# S313G04081



Phillips Head Screw 3/16"x3/8"
Qty. 2
Part # S112G0306E

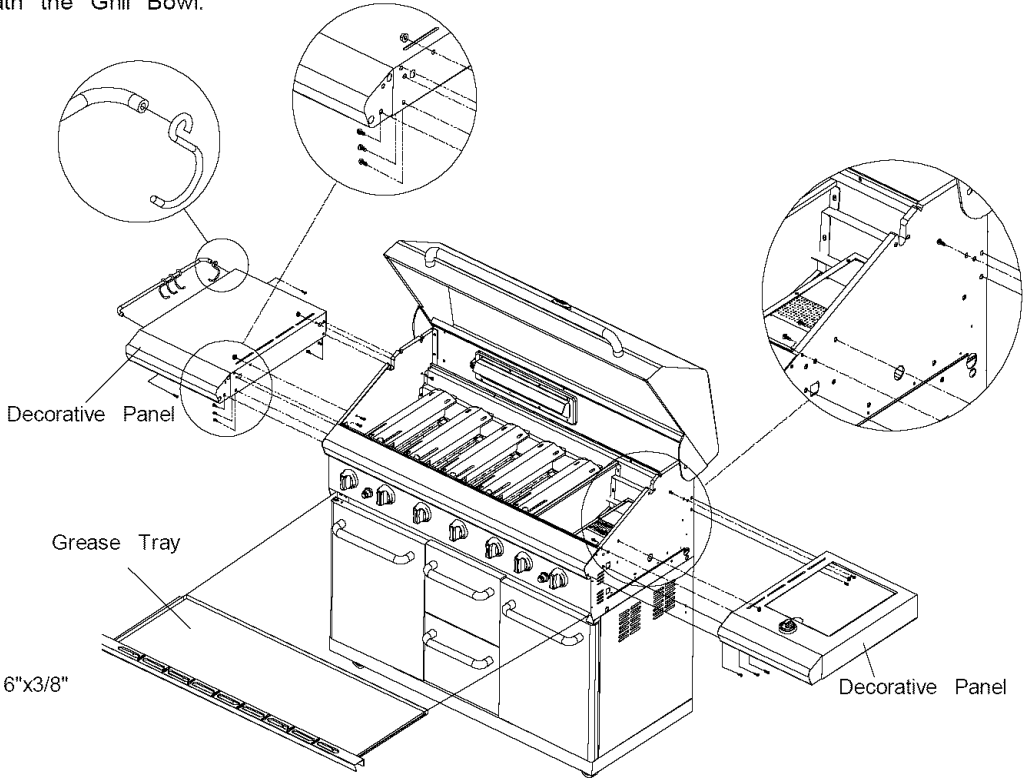

2 Install Side Burner Connection Hose

- Push back Sleeve of the Socket. See Figure A. Insert Plug then release Sleeve. See Figure B. Push Plug until sleeve snaps forward locking the Plug into the Socket. See Figure C.
- Push the Side Burner Hose into hose holder.

Figure A

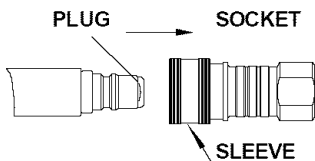

Figure B

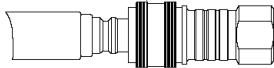
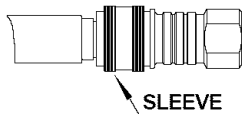
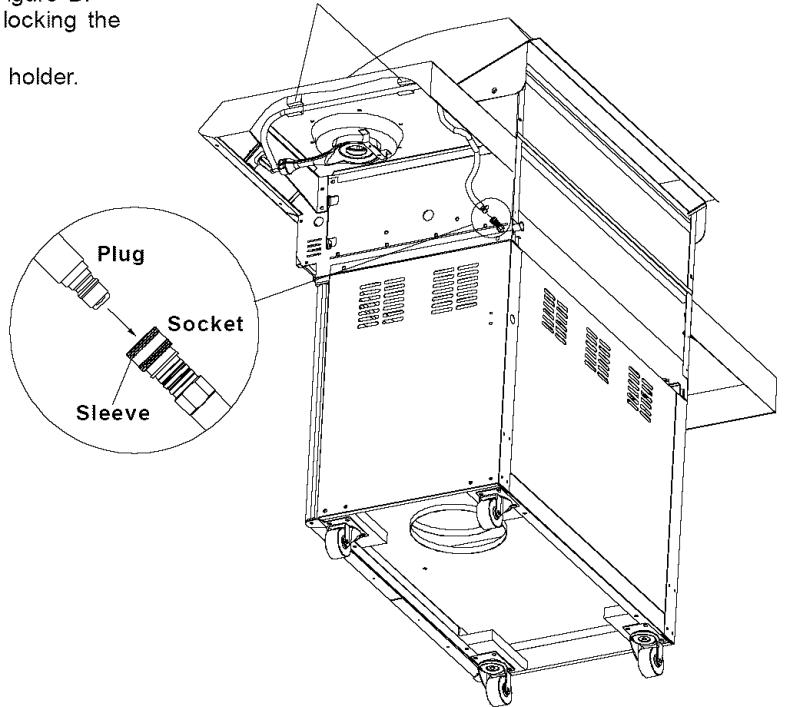

Figure C



Hose Holders



3

Install Ignitor Batteries

- Unscrew Ignitor Cap from Control Panel.
- Place supplied AA batteries into the Ignitor Slots with positive pole facing you.
- Position the Caps and Springs over the AA batteries and tighten onto Control Panel.

4

Main Burners Electrode Check

Perform this Electrode Check with the assistance of another person.

This test will ensure that the Spark Electrode Tips are properly positioned so your grill lights easily and properly.

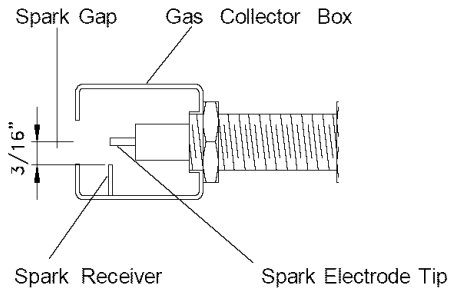

- Be sure all Control Knobs are set to "OFF" and open the Grill Lid.
- Have your assistant stand behind to the right of the grill and look toward the front of the grill bowl. **Never** put your face inside the Grill Bowl.
- Press the Ignitor Cap. You should hear a "clicking" sound. Your assistant should see a blue spark within each Gas Collector Box. If a spark is present the Electrode Tips are properly positioned.
- If no spark is seen, the Spark Gap needs to be adjusted as follows:
 - If the gap between the Spark Electrode Tip and Receiver is more than 3/16" use long nose pliers to gently squeeze the Gas Collector Box to narrow gap.
 - If no "clicking" sound is heard:
 - AA Batteries may be installed backwards.
 - Electric wires may be loose. Remove the AA Batteries and inspect the Ignitor Junction Box found behind the Control Panel and reconnect any loose wires.

5

Side Burner Electrode Check

- Open side burner lid. Remove plastic shipping band from burner and pot support.
- Push and turn side burner Control Knob to HIGH. Look for spark between tip of electrode and burner.
- If you don't see a spark from side burner electrode, adjust gap between electrode and burner surface to 3/16 in.

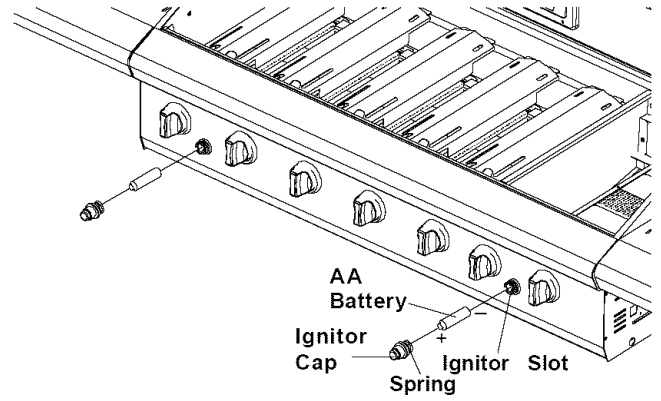

6

Install Cooking Components

- Place the Heat Diffusers on lower ledge above Burners.
- Place Cooking Grids on bowl ledge.
- Place the Secondary Cooking Rack into the slots on Grill Bowl Side Panels

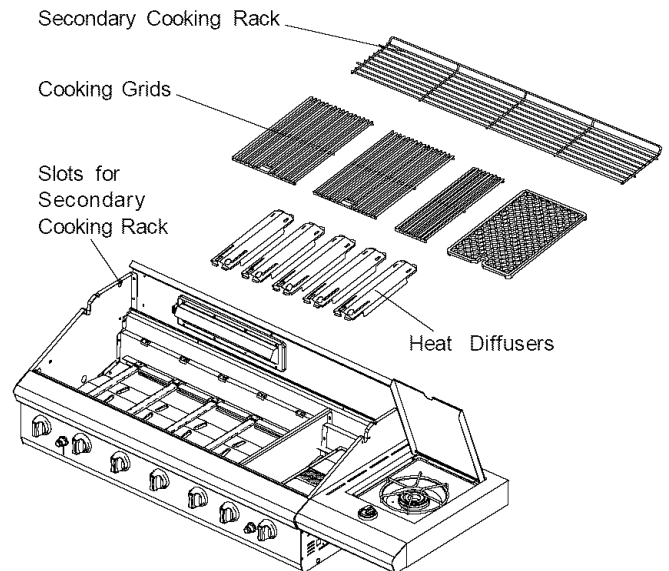

Final Grill Assembly Step

When you have finished assembling your grill be sure that all screws are tightened for safe operation of your grill.



WARNING



Failure to read and follow the Use and Care Instructions could result in a fire or explosion that could cause serious bodily injury, death or property damage.

LP Gas Tank Installation

CORRECT LP GAS TANK USE

- LP Gas grill models are designed for use with a standard 20 lb. Liquid Propane Gas (LP Gas) tank, not included with grill. **Never** connect your gas grill to an LP Gas tank that exceeds this capacity. A tank of approximately 12 inches in diameter by 18-1/2 inches high is the maximum size LP Gas tank to use. **You must use an "OPD" gas tank which offers a listed Overfill Prevention Device.** This safety feature prevents tank from being overfilled which can cause malfunction of LP Gas tank, regulator and/or grill.
- The LP Gas tank must be constructed and marked in accordance with the Specifications for LP-Gas Cylinders of the U.S. Department of Transportation (D.O.T.) or the National Standard of Canada, CAN/CSA-B339, Cylinders, Spheres and Tubes for Transportation of Dangerous Goods; and Commission, as applicable.
- The LP Gas tank must have a shutoff valve, terminating in an LP Gas supply tank valve outlet, that is compatible with a Type 1 tank connection device. The LP Gas tank must also have a safety relief device that has a direct connection with the vapor space of the tank.
- The tank supply system must be arranged for vapor withdrawal.
- The LP Gas tank used must have a collar to protect the tank valve.
- Never** connect an unregulated LP gas tank to your gas grill. The gas regulator assembly supplied with your gas grill is adjusted to have an outlet pressure of 11" water column (W.C.) for connection to an LP gas tank. Only use the regulator and hose assembly supplied with your gas grill. **Replacement regulators and hose assemblies must be those specified by Sears.** See Parts List.
- Have your LP Gas dealer check the release valve after every filling to ensure it remains free of defects.
- Always keep LP Gas tank in upright position.
- Do not subject the LP Gas tank to excessive heat.
- Never store an LP Gas tank indoors. If you store your gas grill in the garage **always** disconnect the LP Gas tank first and store it safely outside.
- LP Gas tanks must be stored outdoors in a well-ventilated area and out of the reach of children.
- Disconnected LP Gas tanks must not be stored in a building, garage or any other enclosed area.
- The regulator and hose assembly can be seen after opening the doors (if applicable) and must be inspected before each use of the grill. If there is excessive abrasion or wear or if the hose is cut, it must be replaced prior to using the grill again.
- Never** light your gas grill with the lid closed or before checking to ensure the burner tubes are fully seated over the gas valve orifices.
- Never** allow children to operate your grill. Do not allow children or pets to play near your grill.
- Use of alcohol, prescription or non-prescription drugs can impair your ability to properly assemble and safely operate your grill.
- Keep fire extinguisher readily accessible. In the event of a oil/grease fire, do not attempt to extinguish with water. Use type B extinguisher or smother with dirt, sand or baking soda.
- In the event of rain, cover the grill and turn off the burner and gas supply.
- Use your grill on a level, stable surface in an area clear of combustible materials.
- Do not leave grill unattended when in use.
- Do not move the appliance when in use.
- Allow the grill to cool before moving or storing.
- Do not use your grill as a heater.
- This grill is not intended to be installed in or on recreational vehicles and/or boats.
- Never use charcoal in this gas grill.

WARNING

A. Do not store a spare LP-Gas tank under or near this appliance.
B. Never fill the tank beyond 80 percent full; and
C. If the information in "(a)" and "(b)" is not followed exactly, a fire causing death or serious injury may occur.

WARNING

- **Use your grill at least 3 feet away from any wall or surface.** Use your grill at least **3 feet away** from combustible objects that can melt or catch fire such as vinyl or wood siding, fences and overhangs or sources of ignition including pilot lights on water heaters and live electrical appliances.
- Outdoor cooking gas appliance shall not be used under overhead combustible construction.
- **Never** use your gas grill in a garage, porch, shed, breezeway or any other enclosed area.
- **Never** obstruct the flow of ventilation air around your gas grill housing.
- In **windy conditions**, always position the front of grill to face oncoming wind to reduce smoke and heat blowing in your face and prevent potential hazards to self and grill.

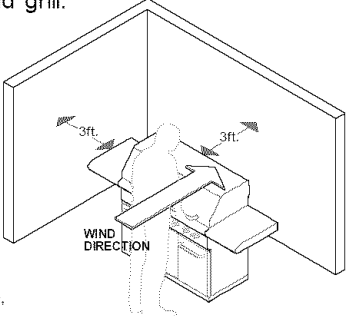

NOTE: For illustration purpose, your grill model may differ.

NOTE about LP Gas Tank Exchange Programs

- Many retailers that sell grills offer you the option of replacing your empty LP Gas tank through an exchange service. Use only those reputable exchange companies that inspect, precision fill, test and certify their tanks. Exchange your tank only for an OPD safety feature-equipped tank as described in the LP Gas tank section of this manual.
- Always keep new and exchanged LP Gas tanks in an upright position during use, transit or storage.
- Leak test new and exchanged LP Gas tanks BEFORE connecting one to your grill.

How to Leak Test your LP Gas Tank

For your safety:

- All leak tests must be repeated each time your LP Gas tank is exchanged or refilled.
- When checking for gas leaks do not smoke.
- Do not use an open flame to check for gas leaks.
- Your grill must be leak tested outdoors in a well-ventilated area, away from ignition sources such as gas fired or electrical appliances. During the leak test, keep your grill away from open flames or sparks.
- Do not use household cleaning agents. Damage to gas assembly components can result.
 - Use a clean paintbrush and a 50/50 mild soap and water solution.
 - Brush soapy solution onto LP Gas tank in the areas indicated by the arrows. See diagram.
 - If growing bubbles appear do not use or move the LP Gas tank. Call an LP Gas Supplier or your Fire Department.

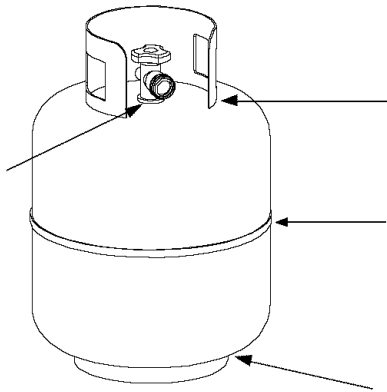

To Install LP Gas Tank (LPG model only): Secure a 20lb LP Gas Tank to Gas Grill

- Screw the Wing Bolt and Special Nut to Cart Bottom Shelf.
- Turn your LP Gas Tank Valve clockwise to the closed or OFF position.
- Place LP Gas tank into tank hole on bottom shelf or (on select models) slide the Tank Tray out of the cabinet until it is fully extended. The Tank Tray has an auto lock position and may need to be pulled firmly.
- Install the tank so the Tank Valve faces the front right corner of cabinet.
- Secure Gas Tank with Special Nut and Wing Bolt.

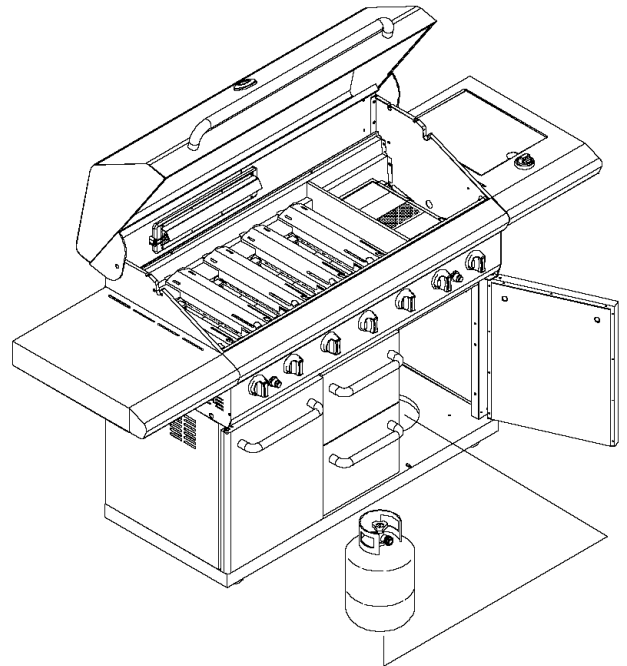

The Special Nut has to be mounted to the Wing Bolt BEFORE inserting tank into tank hole.

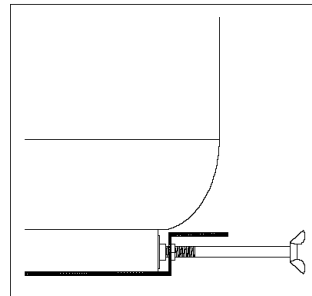

With the Special Nut, the Wing Bolt holds the tank foot firmly.

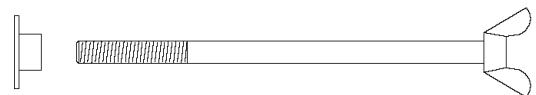

Special Nut 5/16"
Qty. 1
Part. # S303G0504D
Scale 1:2

Wing Bolt 5/16"x4-1/2"
Qty. 1
Part. # S233G05461
Scale 1:2



WARNING



If growing bubbles appear do not use or move the LP Gas tank. Contact an LP Gas Supplier or your fire department!

NOTE: Many different size propane gas tank bottom collars are available in the market, especially with the popularity of tank exchange programs. If your tank bottom collar does not fit into the tank hole after attaching the special nut to the wing bolt, simply remove the special nut and secure the tank using the wing bolt only.

**LP Gas Model only:
Connect Regulator with Hose to your LP Gas Tank**

- Turn all Burner Valves to the OFF position.
- Inspect the valve connection port and regulator assembly for damage or debris. Remove any debris. Never use damaged or plugged equipment.
- Connect the regulator assembly to the tank valve and HAND TIGHTEN nut clockwise to a full stop. DO NOT use a wrench to tighten because it could damage the Quick Coupling Nut and result in a hazardous condition.
- Open the tank valve 1/4 to 1/2 (counterclockwise) and use a soapy water solution to check all connections for leaks before attempting to light your grill. See "**Checking for LP Gas Leaks**". If a leak is found, turn the tank valve off and do not use your grill until the leak is repaired.

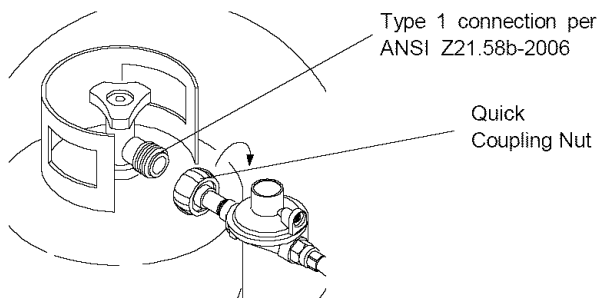

CAUTION: When the appliance is not in use the gas must be turned off at the tank.

Check all connections for LP Gas Leaks

Never test for leaks with a flame. Prior to first use, at the beginning of each season, or every time your LP Gas tank is changed, you must check for gas leaks. Follow these three steps:

- Make a soap solution by mixing one part liquid detergent and one part water.
- Turn the grill Control Knobs to the full OFF position, then turn the gas ON at source.
- Apply the soap solution to all gas connections indicated by the arrows. See diagram. If bubbles appear in the soap solution the connections are not properly sealed. Check each fitting and tighten or repair as necessary.

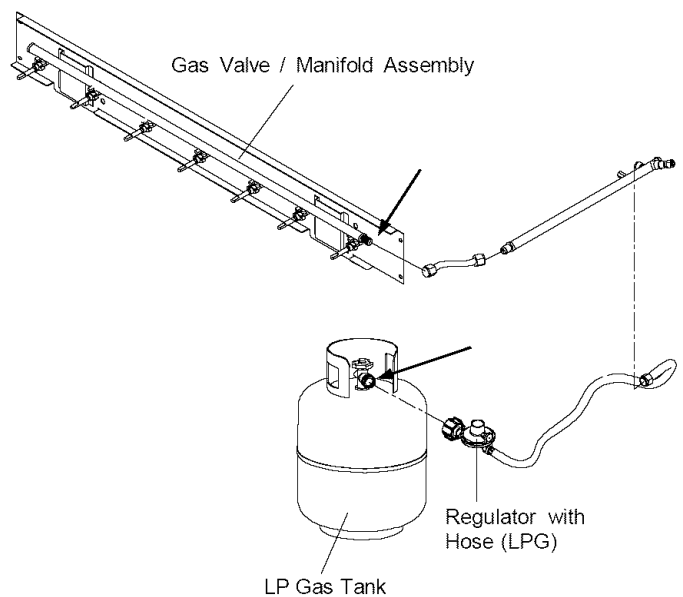

WARNING
<p>If you have a gas leak that cannot be repaired by tightening, turn off the gas at the source, disconnect fuel line from your grill and call 1-800-4-MY-HOME® or your gas supplier for repair assistance.</p>

Disconnecting A Liquid Propane Gas (LPG) Tank From Your Grill

- Make sure the Burner Valves and LP Gas tank valve are off. (Turn clockwise to close.)
- Detach the hose and regulator assembly from the LP Gas tank valve by turning the Quick Coupling Nut counterclockwise.

Natural Gas Connection

Natural Gas Model only: Connecting Natural Gas To Your Grill

- Connect the Swivel nut of the 12' Natural Gas Hose to the vertical fitting of NG Regulator as shown in **Fig. 1**. Connect the other hose end (male plug) to the gas supply line from house. Also, read and follow all natural gas safety instructions below.

Natural Gas Safety Instructions

- Your natural gas grill is designed to operate on natural gas only, at a pressure of 4" water column (W.C.) with natural gas regulator. The gas pressure Regulator supplied with this appliance must be used. This Regulator is set for an outlet pressure of 4" W.C.
- Install a Shutoff Valve at the gas supply source outdoors at a point after the gas pipe exits the outside wall and before the quick-disconnect hose. Or install it at the point before the gas line piping enters the ground. See **Fig. 2**.
- Pipe sealing compound or pipe thread tape resistant to the action of natural gas must be used on all male pipe thread connections.
- Disconnect your gas grill from fuel source when the gas supply is being tested at high pressures. This gas grill and its individual shutoff valve must be disconnected from the gas supply pipe system during any pressure testing of that system at pressure in excess of 1/2 psi (3.5kpa).
- Turn off your gas grill when the gas supply is being tested at low pressures. The grill must be isolated from the gas supply pipe system by closing its individual manual shutoff valve during any pressure testing of the gas supply pipe system at pressures equal to or less than 1/2 psi (3.5kpa).

Figure 2

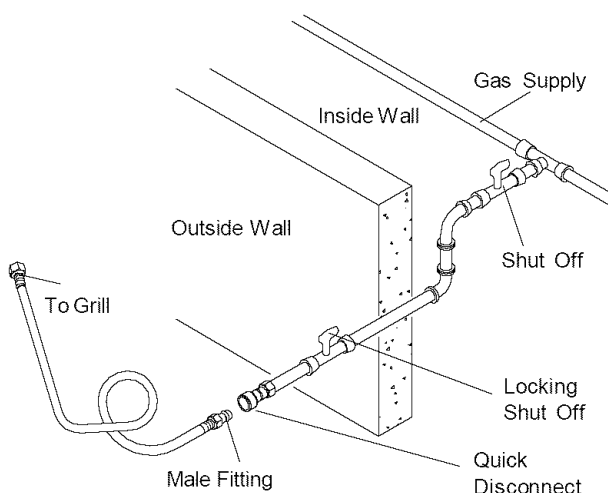
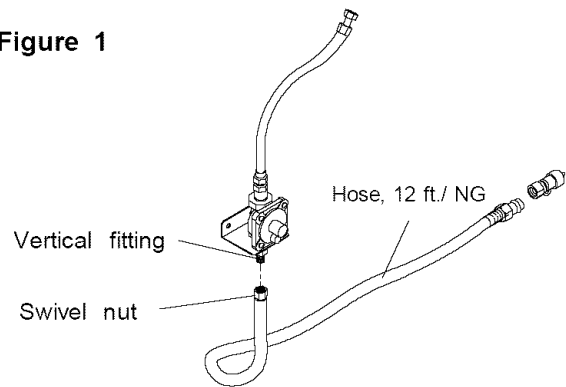

Figure 1



Check all connections for NG Leaks

Never test for leaks with a flame. Prior to first use, at the beginning of each season, you must check for gas leaks. Follow these three steps:

- Make a soap solution by mixing one part liquid detergent and one part water.
- Turn the grill Control Knobs to the full OFF position, then turn the gas ON at source.
- Apply the soap solution to all gas connections indicated by the arrows. See **Fig. 3**. If bubbles appear in the soap solution the connections are not properly sealed. Check each fitting and tighten or repair as necessary.

Figure 3

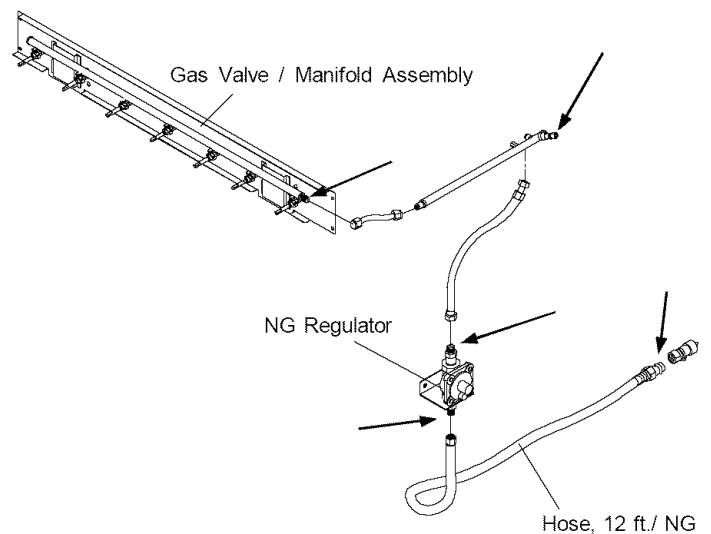

	WARNING	
<p>If you have a gas leak that cannot be repaired by tightening, turn off the gas at the source, disconnect fuel line from your grill and call 1-800-4-MY-HOME® or your gas supplier for repair assistance.</p>		

USE AND CARE INSTRUCTIONS

Grill Lighting Instructions

1. Before each use, check all hoses for cracks, nicks, cuts, burns or abrasions. If a hose is damaged in any way, do not use your grill before replacing the hose with an authorized part from the Parts List. Also make sure all gas supply connections are securely tightened.
2. Familiarize yourself with the safety and Use and Care instructions in this Manual. Do not smoke while lighting grill or checking gas supply connections.
3. Be sure the LP Gas tank is filled.
4. Open the Grill Lid during lighting.
5. Check that the end of each Burner Tube is properly located over each Valve Orifice.



WARNING



Failure to replace a faulty hose, secure gas supply connections or to open the Lid before proceeding to the Lighting Procedures could result in a fire or explosion that could cause serious bodily injury, death, or property damage.

6. Set Control Knobs to OFF and open the LP Gas tank valve **SLOWLY 1/4 of a turn**. For Natural Gas open the Shut Off Valve at source.

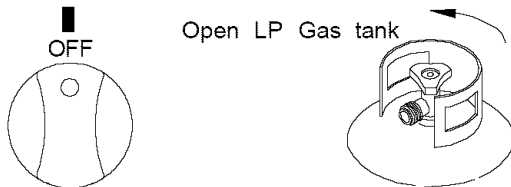

7. Push and turn Burner Control Knob to ⚡ and you will hear a clicking sound as the burner is being ignited. Once the burner is lit, turn the knob back to Hi.

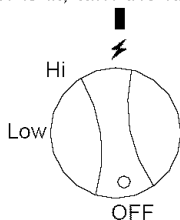

8. If ignition does not occur in 5 seconds, turn gas off at source and turn Control Knobs OFF. Wait at least 5 minutes for gas to clear, then retry. If your grill still fails to light turn the burner Control Knob(s) and gas source OFF and conduct a leak test of ALL gas connections and gas sources as explained in the LP Gas Tank Installation of this manual. If no leaks are detected, wait 5 minutes for any gas to clear and repeat the lighting procedure.
9. After one Burner is lit, turn the tank valve SLOWLY one more 1/4 of a turn.
10. Repeat steps to light each burner individually. Turn Knob for each other burner and light as you move toward the fuel source.

Burner Control Knobs on Control Panel

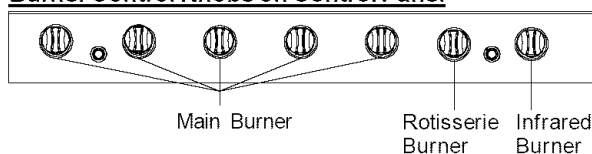

Rotisserie Burner Lighting Instructions

1. Follow steps 1 through 6 of the Grill Lighting Instructions.
2. Push and turn Burner Control Knob to ⚡ and you will hear a clicking sound as the burner is being ignited.
3. Keep pressing while you turn knob to Hi and hold in 5 - 10 seconds before releasing.
4. If ignition does not occur in 5 seconds, turn gas off at source and turn Control Knobs OFF. Wait at least 5 minutes for gas to clear, then retry. If your grill still fails to light turn the Control Knob(s) and gas source OFF and conduct a leak test as explained in the LP Gas Tank Installation of this manual. If no leaks are detected, wait 5 minutes for any gas to clear and repeat the lighting procedure.
5. After Burner is lit, turn the tank valve SLOWLY one more 1/4.

IMPORTANT: Do not use the Rotisserie Burner and Main Burners at the same time. Backburner is for Rotisserie Cooking only.

ROTISSERIE INFRARED BURNER SIDE BURNER
BURNER KNOB: KNOB: KNOB:

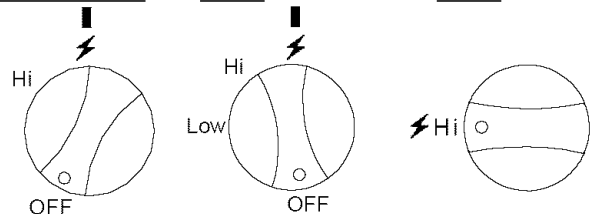

Infrared Burner Lighting Instructions

1. Follow steps 1 through 6 of the Grill Lighting Instructions.
2. Push and turn Burner Control Knob to ⚡ and you will hear a clicking sound as the burner is being ignited.
3. Keep pressing while you turn knob to Hi and hold in 5 - 10 seconds before releasing.
4. If ignition does not occur in 5 seconds, turn the burner Control Knob(s) and gas source OFF and conduct a leak test as explained in the LP Gas Tank Installation of this manual. If no leaks are detected, wait 5 minutes for any gas to clear and repeat the lighting procedure.
5. After Burner is lit, turn the tank valve SLOWLY one more 1/4 of a turn.

Side Burner Lighting Instructions

1. Follow steps 1 through 5 of the Grill Lighting Instructions.
2. Open Side Burner Lid.
3. Set Control Knobs to OFF and open the LP Gas tank valve **SLOWLY 1/4 of a turn**.
4. Push and turn control knob to ⚡ Hi.
5. You may have to push and turn the Control Knob up to 3 or 4 times to light.
6. If ignition does not occur in 5 seconds, turn the burner Control Knob and gas source OFF. Wait at least 5 minutes for gas to clear, then retry. If your grill still fails to light turn the burner Control Knob and gas source OFF and conduct a leak test of ALL gas connections and fuel sources. If no leaks are detected, wait 5 minutes for any gas to clear and repeat the lighting procedure.

Manually Lighting Your Grill By Paper Match

To light your gas grill by match, insert a match into the Lighting Stick and follow steps 1 through 6 of the Grill Lighting Instructions. Then, light the match and place
(continue over page)

USE AND CARE INSTRUCTIONS

Lighting Stick through the Cooking Grid on the grill as shown below. Turn the nearest Control Knob to the HIGH setting to release gas. The Burner should light immediately.

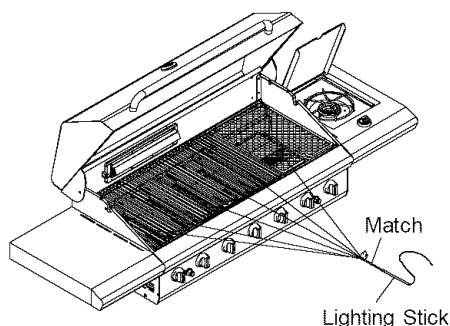

Troubleshooting

If the grill fails to light :

1. Turn gas off at source and turn Control Knobs to OFF. Wait at least 5 minutes for gas to clear, then retry.
2. If your grill still fails to light, check gas supply and connections.
3. Repeat lighting procedure. If your grill still fails to operate, turn the gas off at source, turn the Control Knobs to OFF, then check the following:

- Misalignment of Burner Tubes over Orifices
Correction: Reposition Burner Tubes over Orifices. See Cleaning Burner Tubes and Burner Ports.
- Obstruction in gas line
Correction: Remove fuel line from grill. Do not smoke! Open gas supply for one second to clear any obstruction from fuel line. Close off gas supply at source and reconnect fuel line to grill.
- Plugged Orifice
Correction: Remove Burners from grill by removing the screw from the rear of each Burner using a Phillips Head Screwdriver. Carefully lift each Burner up and away from gas valve Orifice. Remove the Orifice from gas valve and gently clear any obstruction with a fine wire. Then reinstall all Orifices, Burners, Screws and cooking components.

If an obstruction is suspected in Gas Valves or Manifold, call the Grill Information Center. [1-888-317-7642](tel:1-888-317-7642)
- Obstruction in Burner Tubes
Correction: Follow the Burner Tube cleaning procedure on **page 22** of this Use and Care Guide.
- Misalignment of Ignitor on Burner
Correction: Check for proper position of the Electrode Tip as shown in **step 4 page 11**. The gap between the Spark Electrode Tip and Spark Receiver should be approximately 3/16". Adjust if necessary. With the gas supply closed and all Control Knobs set to OFF press the Electric Ignitor cap and check for the presence of a spark at the Electrode.

- Disconnected Electric Wires
Correction: Inspect the Electric Ignitor (see Parts List) found behind the Control Panel. Connect loose Electric wires to Junction Box and try to light the grill.
- Weak AA battery
Correction: Unscrew the Ignitor Cap and replace the battery.
- If the grill still does not light you may need to purge air from the gas line or reset the regulator excess gas flow device. **Note:** This procedure should be done every time a new LP Gas tank is connected to your grill.

To purge air from your gas line and/or reset the regulator excess gas flow device:

- Turn Control Knobs to the OFF position.
- Turn off the gas at the tank valve.
For Natural Gas shut off NG valve.
- Disconnect regulator from LP Gas tank.
For Natural Gas disconnect regulator from 12 ft. Natural Gas Hose.
- Let unit stand 5 minutes to allow air to purge from gas line.
- Reconnect regulator to the LP Gas tank.
For Natural Gas reconnect regulator to 12 ft. Natural Gas Hose.
- Turn tank valve on SLOWLY 1/4 of a turn.
For Natural Gas open Shut Off valve.
- Open the Grill Lid.
- Push and turn the LEFT Control Knob to HIGH.
- Press Electric Ignitor for 3-4 seconds to light the burners.

WARNING

Should a FLASHBACK fire occur in or around the Burner Tubes, follow the instructions below. Failure to comply with these instructions could result in a fire or explosion that could cause serious bodily injury, death, or property damage.

- Shut off gas supply to the gas grill.
- Turn the Control Knobs to OFF position.
- Open the Grill Lid.
- Put out any flame with a Class B fire extinguisher.
- Once the grill has cooled down, clean the Burner Tubes and Burners according to the cleaning instructions in this Use and Care Guide.

GRILL INFORMATION CENTER

Call 8am to 8pm CST **1-888-317-7642** Monday through Friday

USE AND CARE INSTRUCTIONS



WARNING



Never lean over the grill cooking area while lighting your gas grill. Keep your face and body a safe distance (at least 18 inches) from the Lighting Hole or Burners when lighting your grill by match.



WARNING



Keep any electrical supply cord and the fuel supply hose away from any heated surface.

CORRECT ROTISSERIE USE

1. Read all instructions before initial use.

IMPORTANT: When using electrical appliances, basic safety precautions should always be used.

The Rotisserie Motor is set for 120V, 60Hz AC current.

The Rotisserie is for outdoor use only.

Do not let children operate or play nearby your grill or Rotisserie.

Connecting Rotisserie

2. Always attach the assembled Rotisserie to your grill first and then plug the Cord into an outlet.

Operating Rotisserie

3. Do not operate the Rotisserie if the cord or plug becomes damaged, or if the Rotisserie malfunctions or has been damaged in any manner.

The use of accessory attachments is not recommended by the manufacturer and may cause injuries. Do not use this Rotisserie other than for its intended use.

Do not immerse Electrical Cord, Plug or Motor in water or expose to rain, as this may result in an electrical shock.

Disconnect Rotisserie

4. Be careful as all surfaces will be hot, both grill and Rotisserie parts. Use protective mitts to handle the Rotisserie.

Unplug the Rotisserie from electrical outlet when not in use and before cleaning. Allow to cool before adding or removing parts.

When Rotisserie cooking place a Cooking Pan under the food to be cooked as this will capture the drippings and keep your grill clean of excess grease which could cause a fire.

CAUTION: Handle with care when moving a Cooking Pan with hot oils

Should a grease fire occur, turn the burners and gas off and leave the grill lid Closed until the fire is out.

Store the Rotisserie indoors

5. When Rotisserie is not in use, store it indoors in a dry place.

Rotisserie Instructions

1. Remove all components from the carton.
2. Attach the Motor Bracket on the outside of the left grill bowl panel. Align the two holes of the Bracket with the holes on the grill bowl. Tighten securely using two Screws #10-24x3/4" UNC, Plain Washers and Nuts provided.

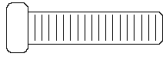

Rot. Screw #10-24x3/4" UNC x2

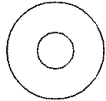

Rot. Washer x2



Rot. Nut #10-24 x2

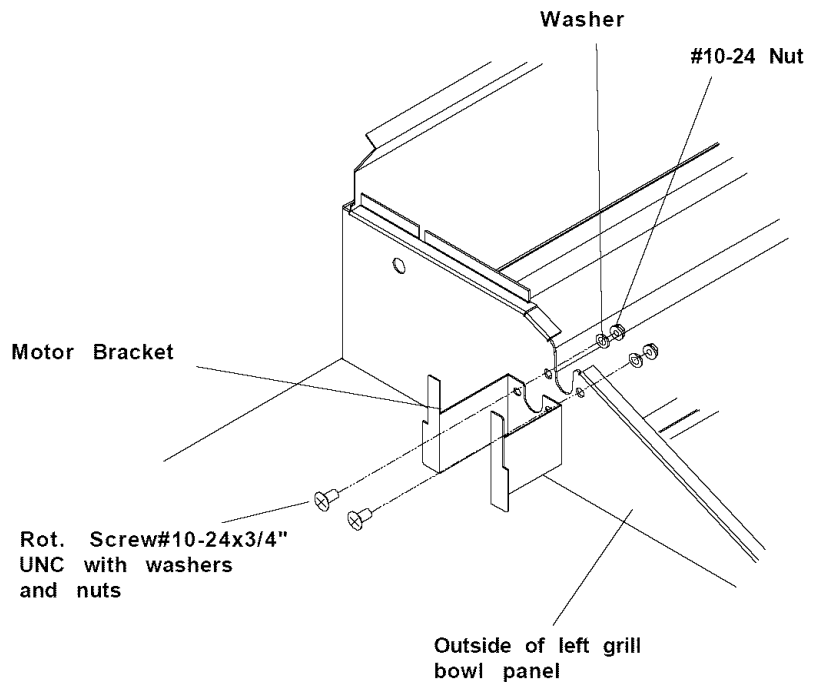

3. Slide the Spit through the piece of meat or poultry and the Holding Forks onto each end of the Rotisserie Spit. Adjust spacing between Holding Forks to accommodate your food, then tighten the Thumbscrews to keep the Holding Forks in position. Slide the Collar and Bushing onto the threaded end of the Spit. Do not tighten the Collar Thumbscrew until the Rotisserie is placed into your grill.

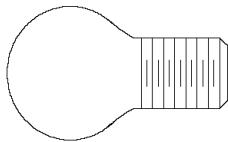

Rot. Thumbscrew 3/8"x1/2" x3

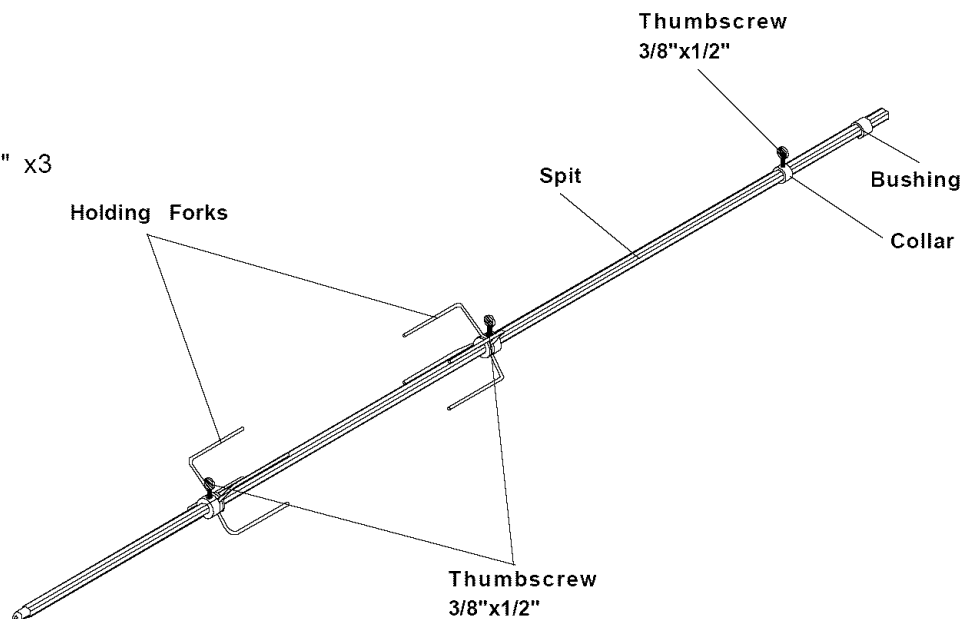

4. Install the AC (alternating current) Rotisserie Motor onto the Motor Bracket as shown below. Be sure the Motor attaches to the Bracket with the electrical cord down.

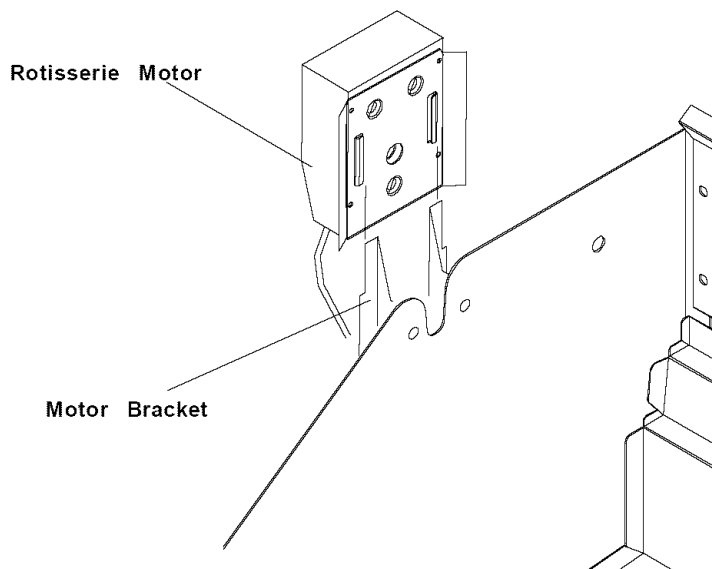

5. Insert the assembled Rotisserie into the Motor as shown below. The Motor should be on the left side of your grill. Place the Bushing into the slot opening on the right side of your grill bowl, then tighten the Collar Thumbscrew to the left of the Bushing. The Collar will stabilize the Rotisserie during the cooking process and the Bushing allows the Rotisserie Spit to turn smoothly. Plug the Rotisserie into an outlet and turn on to test.

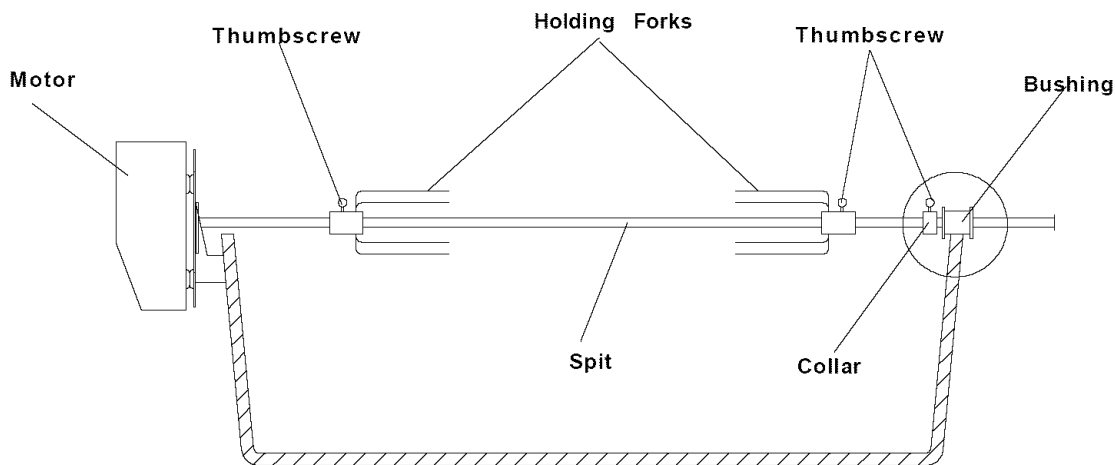

The Bushing and Collar must always be used with this Rotisserie.

BEFORE rotisserie cooking you will need to remove the Cooking Grid(s) and possibly the Heat Diffuser(s) from your grill. When rotisserie cooking place a Cooking Pan under the food to be cooked. This will capture the drippings and keep your grill clean of excess grease which could cause a fire. Use caution when moving a Cooking Pan containing hot oils.

CLEANING AND MAINTENANCE

Proper care and maintenance will keep your grill in top operating condition and prolong its life. Follow these cleaning procedures on a timely basis and your grill will stay clean and operate with minimum effort.

CAUTION: Be sure your grill is OFF and cool before cleaning.

Cleaning The Cooking Grids

- Before initial use, and periodically, wash your Cooking Grids in a mild soap and warm water solution. You can use a wash cloth or vegetable brush to clean your Cooking Grids.

Cleaning The Heat Diffusers

- Periodically you should wash the Heat Diffusers in a soap and warm water solution. Use a vegetable brush to remove stubborn burnt-on cooking residue. Dry the Heat Diffuser thoroughly before you reinstall them into the cooking bowl.

Cleaning The Grease Tray and Receptacle

- To reduce the chance of fire, the Grease Draining Tray and Grease Receptacle (some models) should be visually inspected before each grill use. Remove any grease and wash Grease Tray and Receptacle with a mild soap and warm water solution.

Cleaning the Inside of the Grill Lid

- Grease can have a tendency to build up on the inside of the Grill Lid and could drip onto deck or patio when the lid is opened. Visually inspect the inside of the Grill Lid before each grill use. Remove any grease and wash with a mild soap and warm water solution.

Regular Cleaning of The Grill Interior

- Burning-off excess food after every cookout will keep it ready for instant use. However, at least every 3 months you must give the entire grill a thorough cleaning to minimize your risk of grease fire and keep the grill in top shape. Follow these steps:

1. Turn all Burner Valves to the full OFF position.
2. Turn the LP gas tank valve to the full OFF position. For Natural Gas shut off valve.
3. Disconnect the regulator from the gas tank. Inspect the hose with regulator assembly for cracking, cuts or any other damage, and replace as necessary. Refer to the Parts List in this Use and Care Guide.
4. Remove and clean the Heat Diffusers, Cooking Grids, Cooking Rack and Grill Burners.
5. Cover each Gas Valve Orifice with aluminum foil.
6. Brush the inside and bottom of the grill with a fiber pad or nylon brush and wash with a mild soap and warm water solution. Rinse thoroughly and let dry.
7. Remove aluminum foil from Orifices and check each Orifice for obstruction.
8. Check each Spark Electrode, adjusting as needed. The space between the Spark Electrode Tip and Spark Receiver should be approximately 3/16".
9. Replace the Burners and adjust the Gas Collector Boxes. The edge of each collector box should overlap the first few Burner Ports on the Burner Tube.
10. Replace Heat Diffusers and Cooking Grids.
11. Reconnect the gas source and observe the Burner flame for correct operation.

Cleaning Exterior Surfaces:

Before initial use, and periodically thereafter, we suggest you wash your grill using a mild soap and warm water solution. You can use a wash cloth or sponge for this process. Do not use a stiff wire or brass brush. These will scratch stainless steel and chip painted surfaces (varies by model) during the cleaning process.

Cleaning Exterior Stainless Steel Surfaces:



Routine care and maintenance is required to preserve the appearance and corrosion resistance of stainless steel. The fact is stainless steel can corrode, rust and discolor under certain conditions. Rust is caused when regular steel particles in the atmosphere become attached to the stainless steel surface. Steel particles can also become attached to your grill if you use steel wool or stiff wire brushes to clean the grill instead of non-abrasive cloth, sponge or nylon cleaning tools. In coastal areas rust pits can develop on stainless surfaces that cannot be fully removed. Bleach and other chlorine based solutions used for household and pool cleaning can also cause corrosion to stainless steel.

Weathering, extreme heat, smoke from cooking and machine oils used in the manufacturing process of stainless steel can cause stainless steel to turn tan in color. Although there are many factors which can affect the surface appearance of stainless steel, they do not affect the integrity of the steel or the performance of the grill. To help maintain the finish of stainless steel follow these cleaning procedures for the best results:

After every use (after your grill has cooled down), wipe stainless surfaces with a soft, soapy cloth or sponge then rinse with water. Be sure to remove all food particles, sauces or marinades from stainless steel because these can be highly acidic and damaging to stainless surfaces.

Never use abrasive cleaners, scrubbers or stiff wire brushes of any type on your grill.

Use a heat resistant Stainless Steel Cleaner and rub or wipe in the direction of the stainless steel grain or polish lines NOT against the grain.

 **WARNING** 

Failure to comply with these instructions may result in a hazardous situation which, if not avoided, may result in injury.

Keep grill area clear and free from combustible materials, gasoline and other flammable vapors and liquids.

Do not obstruct the flow of air for combustion and ventilation.

Keep the ventilation openings of the tank enclosure cabinet free and clear of debris.

After completing each burner lighting procedure visually check burner flame pattern as shown below.

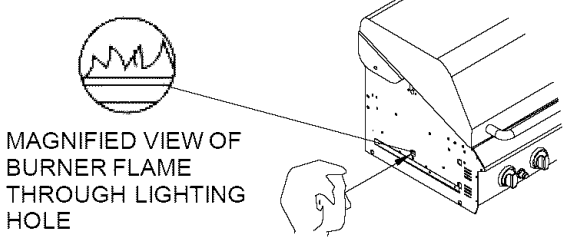

MAGNIFIED VIEW OF
BURNER FLAME
THROUGH LIGHTING
HOLE

CLEANING THE BURNER TUBES AND BURNER PORTS

To reduce the chance of **FLASHBACK FIRE** you must clean the Burner Tubes as follows at least once a month in summer and fall or whenever spiders are active in your area, and if your grill has not been used for an extended period of time.

1. Turn all Burner Valves to the full OFF position.
2. Turn the LP Gas tank valve to the full OFF position.
3. Detach the LP Gas regulator assembly from your gas grill.
4. Remove the Cooking Grids, Heat Diffusers and Grease Trays from your grill.
5. Remove the screw from the rear of each Burner using a Phillips Head Screwdriver.
6. Carefully lift each Burner up and away from the Gas Valve Orifice.
7. Check and clean burner/venturi tubes for insects and insect nests. A clogged tube can lead to a fire beneath the grill.
8. Refer to **Figure 1** and perform one of these three cleaning methods:

- METHOD 1:** Bend a stiff wire or wire coat hanger into a small hook as shown and run the hook through the Burner Tube and inside the Burner several times to remove debris.



- METHOD 2:** Use a bottle brush with a flexible handle and run the brush through the Burner Tube and inside the Burner several times to remove any debris.
- METHOD 3:** Use an air hose to force air through each Burner Tube. The forced air should pass debris or obstructions through the Burner and out the Ports.

Regardless of which Burner cleaning procedure you use, we recommend you also complete the following steps to help prolong Burner life.

1. Use a fiber pad or nylon brush to clean the entire outer surface of each Burner until free of food residue and dirt.
2. Clean any clogged ports with a stiff wire, such as an open paper clip.
3. Inspect each Burner for damage (cracks or holes) and if such damage is found, order and install a new Burner. After installation, check to ensure that the Gas Valve Orifices are correctly placed inside the ends of the Burner Tubes. Also check the position of your Spark Electrode.

WARNING

For safe operation ensure the Gas Valve Assembly Orifice is inside the Burner Tube before using your grill. See figure. If the Orifice is not inside the Burner Tube, lighting the Burner may cause explosion and/or fire resulting in serious bodily injury and/or property damage.

Gas Valve Assembly
Orifice
Burner Tube

Figure 1 Burner

TO CLEAN BURNER TUBE,
INSERT HOOK AS INDICATED BY THE ARROW

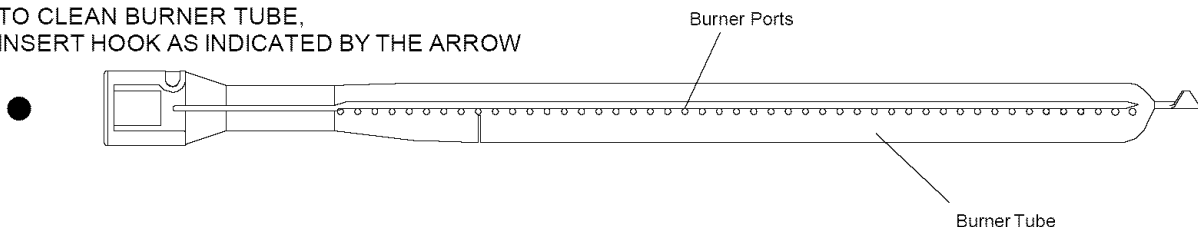

Cooking Instructions

Burn-Off

- Before cooking on your gas grill for the first time, you should "burn off" the grill to eliminate any odor or foreign matter. Ignite the burners, lower the Lid, and operate grill on HIGH setting for 3 to 5 minutes.

CAUTION: Operating ALL main burners on HIGH setting for longer than five minutes may damage certain parts of your grill. Do not leave your grill unattended when in use.

Preheating

- To preheat, light your grill on HIGH, lower the Lid and follow this timetable:
 - For high temperature cooking, preheat grill 3 to 5 minutes.
 - For low temperature cooking, preheat grill 3 minutes.
 - To slow cook, preheating is not necessary.

Cooking Temperatures

- High setting:** The HIGH Control Knob setting should only be used to pre-heat your grill the first 3-5 minutes and for burning food residue off the grill for 3-5 minutes after cooking is complete.

CAUTION: Operating ALL main burners on HIGH setting for longer than five minutes may damage certain parts of your grill. Do not leave your grill unattended when in use.
- Medium to Low Settings:** Most recipes specify medium to low settings, including all smoking, rotisserie cooking and cooking lean cuts such as fish.

An Important Note About Cooking Temperatures

- The suggested heat settings and cooking times shown in the following pages are approximate. Unlike the controlled environment inside your kitchen, variables including outside temperatures, direction and conditions of wind, as well as grill location will affect your grill's heat distribution. Because these conditions vary, and no two backyards are alike, we offer this guide as a convenience. We recommend you monitor your grill closely and rotate foods as needed to prevent overcooking and ensure the most delicious results every time.
- The middle and back primary cooking areas offer the highest heat for searing and grilling.
- The Secondary Cooking Rack offers medium heat for preparing breads and firm vegetables like potatoes and corn.
- The front primary cooking area offers less heat and is ideal for preparing delicate foods and for keeping cooked foods warm.

DirectCooking

- The direct cooking method can be used with the supplied Cooking Grids and food placed directly over the lit grill Burners. **Direct Cooking requires the Grill Lid to be open.** This method is ideal for searing, grilling, deep frying and whenever you want foods to have an open-flame barbecued taste.

IndirectCooking



- The indirect cooking method can also be used with the supplied Cooking Grids. To cook **indirectly**, the food should be placed on the left or right side of your grill with the Burner lit on the opposite side. Or place your food on the Secondary Cooking Rack and light the outer grill Burners. Either way, **indirect cooking must be done with the Lid down.**

Prepare Cooking Grids for Grilling

- Greasing the cooking surface will help keep foods from sticking during the cookout and reduces the amount of cleanup required. Use a brush to apply a thin layer of cooking oil or vegetable shortening onto each Cooking Grid before each cookout. We do not suggest spray type oils unless they are specified for high-temperature cooking. Be sure to coat the entire cooking surface including edges and any areas with chipped porcelain.

Flare-Ups

- The fats and juices dripping from grilled food can cause flare-ups. Since flare-ups impart a favorably, distinctive taste and color to food cooked over an open flame, they should be accepted up to a point. To minimize flare-ups use a drip pan under foods that produce a lot of grease, like ribs.

WARNING

- Failure to comply with these instructions could result in a fire or explosion that could cause serious bodily injury, death or property damage.
- Never cover the cooking grids, bottom of grill bowl or Grease/Water Tray with charcoal, aluminum foil, sand or any substance that can absorb grease.
- **Before each use of your grill:** Pull out the Grease/Water Tray and remove all grease and food debris to prevent grease fire hazard. It is important to keep this Tray filled with water while grilling to get the best possible results. Wear a flame retardant BBQ Mitt when handling the Grease/Water Tray.
- **Use your grill at least 3 feet away from any wall or surface.** Use your grill at least **5 feet away** from combustible objects that can melt or catch fire (such as vinyl or wood siding, fences and overhangs) or sources of ignition including pilot lights on water heaters and live electrical appliances.
- **Never** use your gas grill in a garage, porch, shed, breezeway or any other enclosed area.
- **Your grill will get very hot.** Always wear a flame retardant BBQ Mitt when cooking on your grill and handling the Grease/Water Tray. Never lean over cooking areas while using grill. Do not touch cooking surfaces, Lid, grill housing or other parts while grill is in operation, or until the grill has cooled down after use. Be aware that the Tray does contain water and grease and be extremely careful when removing to prevent spillage.

Guide to Grilling using the Direct Cooking Method

Grilling Steak and Ribs

Turn the grill Burners on HIGH, close the Lid and preheat your grill 3 to 5 minutes. Open Lid and place the meat on the Cooking Grid directly above the lit Burners. Cook the meat on both sides until seared. Reduce the heat to MEDIUM and cook meat until done. Grilling times will vary according to meat thickness.

Grilling Hamburgers and Sausages

Turn the grill Burners on HIGH, close Lid and preheat your grill 3 to 5 minutes. Open Lid and place the meat on the Cooking Grid directly above the lit Burners. Cook the meat on both sides until seared. Reduce the heat to MEDIUM and cook the meat until done. Grilling times will vary according to meat thickness.

Grilling Poultry

Turn the grill Burners on HIGH, close Lid and preheat your grill 2 to 3 minutes. Then raise the Lid, reduce heat to MEDIUM and cook poultry directly over lit Burners until done. Poultry skin is fatty so you should expect some flare-ups when using this direct method.

To minimize flare-ups, try grilling poultry using the indirect method. Place the poultry on one side of the grill with the opposing Burners on MEDIUM heat, and lower the grill Lid. Grilling times will vary based on the size of your poultry.

Grilling Pork

Turn Burners on HIGH and preheat your grill 3 to 5 minutes with the Lid closed. Raise Lid, place pork on Cooking Grid and cook until seared. Reduce heat to MEDIUM and cook until done. Grilling times will vary according to meat thickness.

Whole Fish and Whole Fillets

Preheat your grill on HIGH for 2-3 minutes with the Lid down. Raise lid and turn Burners to MEDIUM heat. Place fish (skin down) on grill and cook over direct heat until done. Use cooking time as a guide or until fish is opaque but still moist.

Smaller Fish Fillets and Cubes

Follow the directions from above, using approximate cooking times shown at right. Place a small piece of aluminum foil on the Cooking Grids if the fish pieces are small enough to drop between the Cooking Grids.

Vegetables and Fruit

Prepare your fruit or vegetables and brush with butter or basting sauce if desired. To cook **indirectly**, the food should be placed on the left or right side of your grill with the Burner lit on the opposite side and the grill lid down. Or center your food on the Secondary Cooking Rack and light the outer grill Burners. Either way, **indirect cooking must be done with the Lid down.**

In some instances, you may want to grill vegetables and fruit **directly** over the heat, using the supplied Cooking Grids. Foods that work best with direct heat are relatively soft and require a short cooking time: mushrooms, zucchini, tomatoes and skewered fruit such as apricots, peaches, pineapple, strawberries and kiwis. Remember the **Grill Lid must remain up when cooking directly.**

Cut of Meat

T-bone steak
Sirloin steak
Beef spare ribs
Porterhouse steak
New York strip steak

Approximate Cooking Times

Rare: 4-8 minutes
Medium: 10-14 minutes
Well done: 15-20 minutes

Hamburgers
Sausages

Rare: 4-6 minutes
Medium: 8-10 minutes
Well done: 10-15 minutes

Chicken breast
(cook with bone down)
Chicken wings
Drumsticks

Direct method:
approximately 15 minutes
Indirect method:
up to 30 minutes

Whole bird
(cook with breast up)

Indirect method:
approximately 1 hour

Chops
Loins
Cutlets

Medium: 10-14 minutes
Well done: 15-20 minutes

Whole fish
Whole fish fillets

10 - 12 minutes per pound or
until fish is opaque

Fish fillets
Boneless cubes

4 - 5 minutes each side
or until fish is opaque

For very firm vegetables—particularly potatoes and yams, we recommend that you partially boil until almost cooked, before placing them on the grill. Cooking times using the **indirect method** with the lid down will be similar to those for your kitchen oven. However, there are many factors such as outside temperature, wind conditions and location of grill that affect your grill performance so we suggest you watch the temperature gauge and adjust the heat accordingly.

Cooking times for foods prepared with the **direct method** will be much shorter mainly because of the direct heat source and softness of the food. Timing will be comparable to normal pan frying or grilling.

Guide to Slow Roasting and Baking Techniques

An Important Note About Heat Settings

The suggested heat settings shown are approximate. There are many factors such as outside temperature, wind conditions and grill location that affect your grill performance. We offer these cooking times as a convenience, but suggest you watch the temperature gauge and adjust the heat accordingly.

Preparing to Roast

Roasting uses the **indirect cooking** method. Therefore, the food should be placed on the left or right side of your grill with the Burner lit on the opposite side. You can also use the supplied Cooking Grid with an aluminum drip pan underneath allowing you to collect juices for making gravies. Remember, indirect cooking requires the Lid of your grill to be down.

Preheating your grill is not required for slow cooking methods such as roasting. If you do choose to preheat your grill before roasting, turn the Burners on HIGH and close Lid for approximately 2-3 minutes.

Food preparation

Trim meat of excess fat. Truss meat and poultry with cooking string to retain shape if desired. Bacon strips can be used to cover the outside surface of lean meat and poultry to help prevent it from drying out. Another method for keeping food moist during roasting is to put water in a cooking pan, then cover with foil. The foil should be removed for the first or the last part of the cooking time to ensure proper browning.

Tips for roasting

Except when roasting with water in a roasting pan, the juices that collect in the pan can be used as the base for a tasty sauce or gravy. Place a cooking pan directly over the heat, add extra butter if needed, then add several spoonfuls of flour to thicken sauce. Finally, add sufficient chicken or beef stock to obtain the desired consistency.

Once the meat is cooked, remove it from your grill and cover with a piece of foil. Allow it to stand for 10-15 minutes which allows the juices to settle. This will make carving easier and ensure a tender, juicy roast.

Type of Food	How Cooked	Approximate Cooking Times
Beef	Rare	18 minutes per pound
	Medium	23 minutes per pound
	Well done	27 minutes per pound
Lamb	Medium	18 minutes per pound
	Well done	23 minutes per pound
Veal		27 minutes per pound
Pork		30-33 minutes per pound
Chicken		20-25 minutes per pound
Duck		25 minutes per pound
Fish		10 minutes per pound
Turkey, under 16 pounds		20-25 per pound + 30 minutes
Turkey, over 16 pounds		18-23 per pound + 15 minutes

BAKING TECHNIQUES

From casseroles and cornbread to delicious desserts like fondue fruit skewers or crumb cake, baking on the grill is as easy as baking in the kitchen.

Preparing to Bake

To bake in your new grill you'll need a baking dish or cast-iron cooking pan, and a pair of flame retardant BBQ Mitts. If the cooking pan is cast-iron be sure to season the pan before use.

Preheat your grill 3-5 minutes, then lower heat to achieve the baking temperature desired. Baking uses the **indirect cooking** method. Therefore, your cooking pan should be

placed on the left or right side of your grill with the burners lit on the opposite side.

Tips for Baking

Prepare your favorite recipe as you would in the kitchen. Foods cooked in the grill for long periods of time should always be covered in aluminum foil to retain moisture. You will need to stir the food several times as it bakes, and add additional liquid if required.

Watch the temperature, and adjust to cook according to your recipe directions.

Oven Temperature

Slow	300° - 340° F
Moderate	355° - 390° F
High	410° - 480° F

Recommended Grill Setting

Both outside Burners on LOW
1 outside Burner on HIGH and 1 outside Burner on LOW
Both outside Burners on HIGH

Guide to Rotisserie Cooking

Slow Cooking with a Rotisserie

Rotisserie cooking produces foods that are moist, flavorful and attractive. The optional rotisserie system is most commonly used for cooking meat or poultry and is designed to cook food slowly. You can place a cooking pan beneath the food to collect juices for basting and gravy. To flavor the contents of the cooking pan you may add herbs, onions, or other spices of your choice.

The cooking times on a rotisserie will be approximately the same as for oven cooking.

Balancing the Food

In rotisserie cooking, balancing the food is of utmost importance. The rotisserie must turn evenly or the stopping and starting action will cause the food to cook unevenly and possibly burn the heavier side.

The easiest foods to balance are those of uniform shape and texture. To test if the food is balanced correctly when secured, place the ends of the rotisserie spit loosely in the palms of your hands. If there is no tendency to roll, give the spit a quarter turn. If it is still stable, give it a final quarter turn. It should rest without turning in each of these positions. It can then be attached to your grill.

Food Preparation

When preparing poultry, truss the birds tightly so that wings and drumsticks are close to the body of the bird. The cavity of the bird may be stuffed prior to this. Pull the neck skin down and, using a small skewer, fix it to the back of the bird. Push the rotisserie spit through lengthwise, catching the bird in the fork of the wishbone. Center the bird and tighten with the holding forks. Test the balance as described before.

A rolled piece of meat requires the rotisserie skewer to be inserted through the center of the length of meat, then secured and balanced.

For meats that contain bones, it is best to secure the rotisserie skewer diagonally through the meaty sections. If protruding bones or wings brown too quickly, cover with pieces of foil.

Guide to Smoking

Preparing to Smoke

Smoking gives food a distinctive, delicious flavor. You will find a variety of wood chips available for use in smoking grilled foods. Pre-soaking of wood chips may be required so read and follow the manufacturers instructions for preparing smoking chips prior to use.

Note: It is our experience that many smoking chip products do not actually produce a smoke but instead infuses the food with flavor. Please read product labels carefully and if in doubt, ask your retailer for details.

Using A Smoker Box

There are many optional smoker boxes available for purchase. Follow these guidelines and always refer to the label of your smoking chips for specific directions.

Raise your Grill Lid and light the grill. Lower the Grill Lid allowing your grill to reach the desired cooking temperature for the food you are grilling. Fill your smoker box with your prepared smoking chips. Dried herbs and spices may also be added to produce different flavors. Wear a flame retardant BBQ Mitt and place your smoker box on a Cooking Grid or Heat Diffusers directly above a lit grill Burner. The heated smoking chips will flavor your foods.

Tips for Smoking

You can reduce the strength of the smoke flavor by only smoking for half or three quarters of the cooking time. The heat required for smoking is normally LOW to MEDIUM.

Foods naturally high in oils lend themselves well to smoking, while drier foods benefit from a marinade.

- **Tuna steaks**, marinated in Asian flavors of sesame oil, soy sauce and sherry.
- **Pork filets**, rubbed with ginger, orange rind and brushed with maple syrup.
- **Mussels**, brushed with lemon rind and chili oil.
- **Lamb cutlets**, marinated in virgin olive oil, lemon, oregano and black pepper. The same marinade can be used for a whole leg or rack of lamb.
- **Chicken**, boneless chicken pieces—especially sliced breasts.
- **Fish**, sliced filets of firm fish, assorted seafood such as prawns, scallops and calamari.
- **Pork**, sliced filets, diced or minced pork, sliced leg steak, sliced chops.
- **Beef**, sliced fillet, rib-eye, round, rump, sirloin.
- **Lamb**, sliced fillet, round, loin.

Guide to Stir-Frying and Deep-Frying

STIR-FRYING TECHNIQUES

This method of cooking is popular around the world and can be easily accomplished outdoors on your gas grill. It's a quick and healthful way of preparing a complete meal using meat, poultry or seafood in infinite combinations with other interesting ingredients like vegetables, rice or noodles.

Preparing to Stir-fry

Although it is possible to stir fry in other dishes, a wok is your best tool. Its high sides enable the cook to stir food without spillage. Its construction allows you to cook quickly at high temperatures, with instant control of heat which is essential for successful stir frying.

Food preparation

Slice meat and poultry into long thin strips and cube fish fillets. Remove all fat from meat and poultry and cut large vegetables into even slices or cubes.

Marinate foods for extra flavor and tenderness. Marinating times will vary for red meat, fish and or various cuts. Less tender cuts of meat should be marinated longer. Remember to always chill marinating food in the refrigerator prior to cooking.

Stir-fry meats, poultry or fish first. Next, add hard vegetables like carrots. Then continue with softer vegetables like snowpeas and peppers. To ensure even cooking, continually stir and toss the food in the wok using a wooden spoon or spatula.

Tips for Stir-frying

Place a wok on a Cooking Grid or Side Burner directly over a HIGH heat . Add only a small amount of food at a time to ensure fast cooking and also to allow the wok to reheat between ingredients.

DEEP-FRYING TECHNIQUES

A wide variety of foods can be deep-fried outdoors on your grill, from potatoes, to seafood and chicken. Deep-frying uses a large portion of oil, preferably saturated. The outdoor location is ideal for deep-frying as smoke, grease and smells disperse in the open air instead of collecting on the ceiling of your kitchen.

Preparing to Deep-fry

Deep-fry on your grill using a cooking pan or wok, over direct heat.

Fill a cooking pan no more than half full of vegetable or corn oil. Start with LOW heat, then raise the heat gradually. Check the temperature of the oil carefully with a frying thermometer or test with a cube of bread. The cube of bread should brown in about 30 seconds for most cooking needs. A temperature between 350 and 400 degrees is optimal for preparing the majority of deep-fried foods.

Food Preparation

Foods being deep-fried taste better when coated with either batter or breadcrumbs to add flavor and prevent moisture from escaping.

Tips for Deep-frying

Wear a flame retardant BBQ Mitt and slowly lower foods into the hot oil using a wire scoop or stainless steel tongs. Add only a small quantity of food to the oil, allow it to cook, then repeat with another small quantity. This ensures the oil doesn't drop in temperature. Once the food is cooked, remove it carefully and drain onto a paper towel. Turn the heat off as soon as you have finished deep-frying and allow your pan to cool. When the oil is cool, remove all remnants of fried foods by straining it through a fine metal sieve, and store it in a clean bottle for future use.

Guide to Using the Secondary Rack

Vegetables are generally easy to cook on the grill. The Secondary Rack makes it convenient because you can still use the main cooking area while the vegetables are suspended above the grids.

Pre-cook hard vegetables by briefly boiling or microwaving them before cooking on the grill. Wrap vegetables in a double thickness of foil to protect them while cooking on the grill. Then, remove the foil if desired, 10-15 minutes before the end of cooking, brush vegetables with butter or oil and finish cooking.

The Secondary Rack can be used for purposes other than just the obvious. Consider using the rack for warming French bread, garlic bread, croissants or even bagels.

A small whole fish wrapped in foil also cooks well on the Secondary Rack. Parcels of seafood such as scallops, prawns and sliced fish fillets prepared in a sauce and portioned into small foil wraps cook well this way, too.

Don't Forget Your Grill Accessories

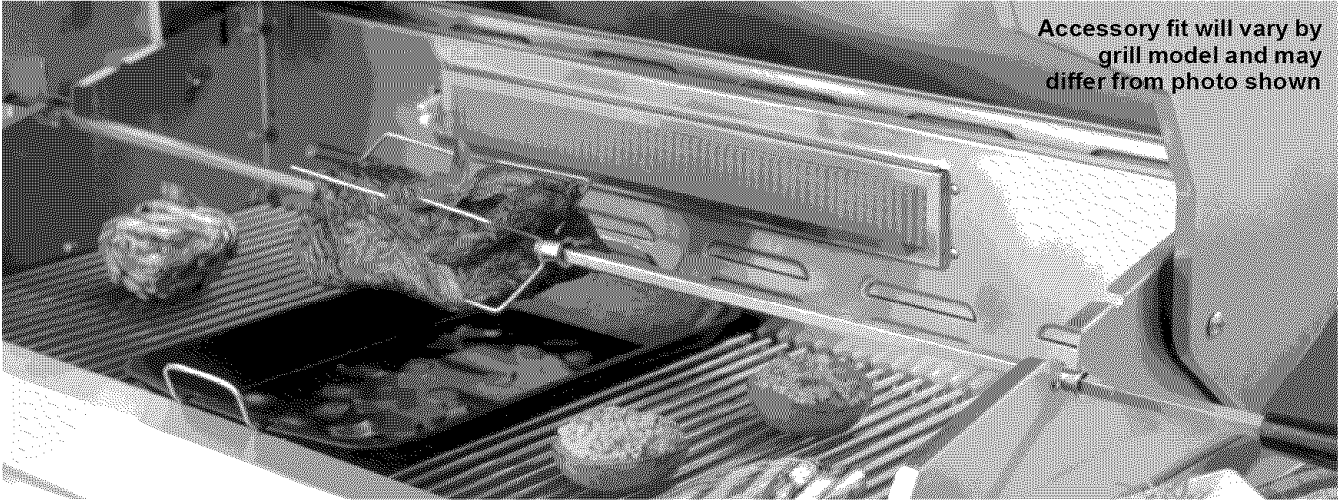

Accessory fit will vary by grill model and may differ from photo shown

Anything you enjoy cooking indoors can be prepared outdoors as well. These optional grill accessories make it easy to enjoy your new Kenmore or Kenmore Elite grill as an outdoor kitchen.

Not all locations carry all items and availability is limited to supplies on hand. Accessory fit will vary by grill model so ask a sales associate for details.

Grill accessories are offered at most larger Sears full line stores, Sears Grand, Sears Hardware, The Great Indoors, Orchard Supply Hardware and sears.com.

Rotisserie cooking produces foods that are moist and flavorful because the slowly rotated food self-bastes to seal in meat's natural juices. Use a Rotisserie Kit to slow cook foods using the indirect cooking method or an infrared back burner, a feature available on some models.

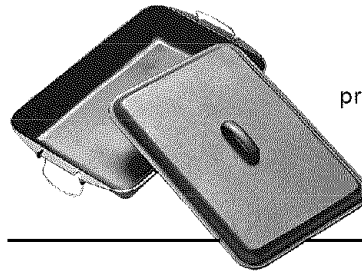

Versatile cast-iron Pan and Lid set is ideal for preparing deep dish pizza, cornbread, casseroles and deserts.

Reversible cast-iron Griddle offers a flat side for grilling breakfast, fish and fajitas and a ribbed side for cooking bacon, sausages and burgers.

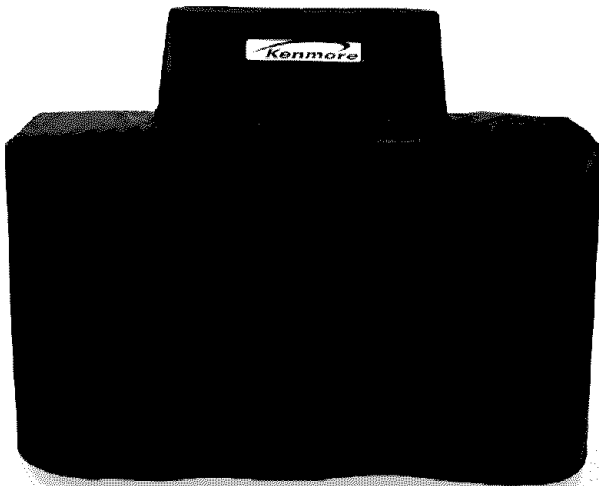
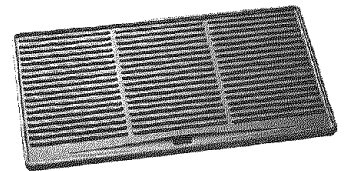

Protect your grill from rain, snow and seasonal debris with a quality made grill cover. Fit varies by grill model.

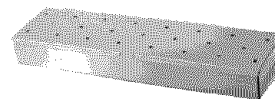

Load this Smoker Box with your favorite chips and add flavor to grilled foods.

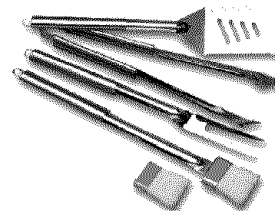

Quality 304 grade stainless steel grill tools offer long reach handles for easier outdoor cooking.

Call the Grill Information Center if you have any problem with this product. We can help with questions about assembly, grill operation, accessory availability or if there are damaged or missing parts when you unpack this unit from the shipping box. Please call us before contacting your local retailer.

GRILL INFORMATION CENTER

Call 8am to 8pm CST **1-888-317-7642** Monday through Friday

Question:

Can I convert my grill from one fuel type to another in other words from LPG to NG or vice versa?

Answer:

No, your gas grill is manufactured to exact specifications and is certified for LPG (Liquid Propane Gas) or NG (Natural Gas) use only. For your safety, conversion kits are not available, nor will we sell or otherwise provide parts or information to be used to convert your grill. Any attempt to convert your grill is dangerous and will void your warranty.

Question:

Are the serial and model numbers of my grill listed somewhere for reference?

Answer:

The serial and model numbers are listed on a silver CSA label placed on the grill. Depending on the grill model, the silver CSA label will be located on the left or right side bowl panel underneath the side shelf, underneath the right side of the control panel, outside left or right of control panel or on the back of the grill cabinet.

Question:

My grill will not light properly. Why?

Answer:

Try this procedure:

1. Turn gas off at source and turn Control Knobs OFF. Wait at least 5 minutes for gas to clear, then retry.
2. If your grill still fails to light, turn the Burner Control Knob(s) and gas source OFF and conduct a leak test of ALL gas connections and gas sources as explained in the Use and Care section of this manual.
3. If no leaks are detected, wait 5 minutes for any gas to clear and repeat the lighting procedure.

Question:

If my ignitor or battery is not working how can I light my grill manually? And - Why would I need the silver lighting stick that hangs from the side of my grill?

Answer:

If your ignition fails to work or your battery needs replacing, you can light your grill through the Cooking Grid of the grill bowl using the Manual Lighting Stick that hangs from the side of your grill. The Lighting Stick is designed to hold a paper match and allows you to safely insert a match through the Cooking Grid without getting close to the Burner. To light your gas grill manually, insert a paper match into the Manual Lighting Stick and follow steps 1 through 5 of the Basic Lighting Procedures. Then, light the match and place it through the Cooking Grid of the grill bowl. Turn the far right Burner Control Knob to the High setting to release gas. The Burner should light immediately.

Question:

Sometimes I hear a humming sound coming from my regulator. What causes this? And - My grill has a low flame and sometimes will not light. Why?

Answer:

The humming sound is gas flowing through the regulator. A low volume of sound is normal and will not interfere with the operation of your grill. Loud or excessive regulator humming and/or low flow and intermittent lighting may be caused by the regulator's excess gas flow device. Opening the tank valve all the way or too quickly is what triggers the regulator's safety device to restrict gas flow, preventing excess gas flow to your grill. Lighting the main Burner farthest from the fuel source every time will help eliminate air pockets in the manifold. Note: This procedure should be done every time a new LP Gas tank is connected to your grill.

- Turn all Control Knobs to the OFF position.
- Turn off the LP Gas tank at the tank valve.
- Disconnect regulator from LP Gas tank.
- Let unit stand for 5 minutes.
- Reconnect regulator to the LP Gas tank.
- Open grill Lid (or Side Burner Lid if you are lighting the Side Burner)
- Turn the tank valve slowly ¼ of one turn.
- Light the left main Burner.
- Turn the LP tank valve slowly one more ¼ of one turn.
- Turn other burner Control Knobs to Hi to light as you move towards the LPG tank.
- Do not turn tank valve more than ½ of one turn.

Question:

Where do I use my grill for safer operation and better performance?

Answer:

- Strong winds and low temperatures can affect the heating and performance of your gas grill so factor in these elements when positioning your grill outdoors for cooking.
- Use your grill at least 3 feet away from any wall or surface.
- Use your grill at least **3 feet away** from combustible objects that can melt or catch fire such as vinyl or wood siding, fences and overhangs or sources of ignition including pilot lights on water heaters and live electrical appliances.
- Never** use your gas grill in a garage, porch, shed, breezeway or any other enclosed area.
- Never** obstruct the flow of ventilation air around your gas grill housing.
- Always** operate grill on a level surface.

Question:

The Regulator and Hose supplied with my gas grill does not fit the older LP Gas tank I've used for years. Why not?

Answer:

The U.S. Government regulates gas appliances and LP Gas tanks. When regulations are changed the LP Gas tank fittings are altered to insure compliance. If your LP Gas tank does not fit the Regulator and Hose supplied with your new grill, the tank is outdated and must be replaced. Note: Effective April 1, 2002 all LP Gas tanks sold must include an "OPD" Overfill Prevention Device. The OPD tanks are identified by their triangular-shaped valve wheel. This internal device prevents the LP Gas tank from being overfilled. Tanks without an OPD valve can not be refilled.

Question:

Is it safe to clean my porcelain coated cooking grids in the dishwasher?

Answer:

Clean your cooking grids by hand if there are any chips or cracks in the porcelain finish and dry them thoroughly. If no chips or cracks are present it should be safe to use the dishwasher. Remember to dry the cooking grids thoroughly before placing back onto your grill to minimize rusting.

Question:

What causes cast-iron or steel grill parts to rust and what affect does it have on my grill?

Answer:

Rusting is a natural oxidation process and may appear on cast-iron and steel parts. Rust will not affect the short term performance of your grill.

To slow the rusting process on steel Cooking Grids (select models) we recommend greasing the Cooking Grids before and after each cookout. Use a brush to apply a thin layer of cooking oil or vegetable shortening onto each Cooking Grid. We do not suggest spray type oils unless they are specified for high-temperature cooking. Be sure to coat the entire cooking surface including edges and any areas with chipped porcelain.

Question:

Which is a better cooking surface to grill on; porcelain coated steel / cast-iron cooking grids or stainless steel grids?

Answer:

They all have their advantages. For traditional grilling and searing meats, cast-iron or steel grids offer better heat conductivity. To protect against the natural rusting process, steel or cast-iron cooking grids offer a porcelain finish which requires routine maintenance to keep the grids well seasoned.

Stainless steel is popular with those who prefer less maintenance.

A new innovative solution is available on select models called Stainless Clad Therma-Core[®]. This Cooking Grid combines a heat conducting steel core with an easy-to-clean stainless outer shell.

Repair Protection Agreements

Congratulations on making a smart purchase. Your new Kenmore® product is designed and manufactured for years of dependable operation. But like all products, it may require repair from time to time. That's when having a Repair Protection Agreement can save you money and aggravation.

Here's what the Repair Protection Agreement* includes:

- **Expert service** by our 10,000 professional repair specialists.
- **Unlimited service and no charge** for parts and labor on all covered repairs.
- **Product replacement** up to \$1500 if your covered product can't be fixed.
- **Discount of 10%** from regular price of service and related installed parts not covered by the agreement; also, 10% off regular price of preventative maintenance check.
- **Fast help by phone** – we call it Rapid Resolution – phone support from a Sears representative. Think of us as a “talking Use and Care Guide.”

Once you purchase the Repair Protection Agreement, a simple phone call is all that it takes for you to schedule service. You can call anytime day or night, or schedule a service appointment online.

The Repair Protection Agreement is a risk-free purchase. If you cancel for any reason during the product warranty period, we will provide a full refund. Or, a prorated refund anytime after the product warranty period expires. Purchase your Repair Protection Agreement today!

Some limitations and exclusions apply. For prices and additional information in the U.S.A. call 1-800-827-6655.

*** Coverage in Canada varies on some items. For full details call Sears Canada at 1-800-361-6665.**

Sears Installation Service

For Sears professional installation of home appliances, garage door openers, water heaters, and other major home items, in the U.S.A. or Canada call **1-800-4-MY-HOME®**.

Get it fixed, at your home or ours!

Your Home

For repair – **in your home** – of all major brand appliances, lawn and garden equipment, or heating and cooling systems, **no matter who made it, no matter who sold it!**

For the replacement parts, accessories and owner's manuals that you need to do-it-yourself.

For Sears professional installation of home appliances and items like garage door openers and water heaters.

1-800-4-MY-HOME® (1-800-469-4663)

Call anytime, day or night (U.S.A. and Canada)

www.sears.com www.sears.ca

For expert home solutions advice: www.managemyhome.com

Our Home

For repair of carry-in items like vacuums, lawn equipment, and electronics, call or go on-line for the location of your nearest

Sears Parts & Repair Service Center

1-800-488-1222 (U.S.A.) **1-800-469-4663** (Canada)

Call anytime, day or night

www.sears.com www.sears.ca

To purchase a protection agreement on a product serviced by Sears:

1-800-827-6655 (U.S.A.)

1-800-361-6665 (Canada)

Para pedir servicio de reparación a domicilio, y para ordenar piezas:

1-888-SU-HOGAR®

(1-888-784-6427)

Au Canada pour service en français:

1-800-LE-FOYER^{MC}

(1-800-533-6937)

www.sears.ca

The Sears logo is displayed in a large, bold, black serif font. The word "Sears" is written in a classic, slightly stylized typeface. Below the letters "e" and "a", there is a thin, curved underline that sweeps under the letters and extends slightly to the right.

© Registered Trademark / TM Trademark / SM Service Mark of Sears Brands, LLC
© Marca Registrada / TM Marca de Fábrica / SM Marca de Servicio de Sears Brands, LLC
^{MC} Marque de commerce / ^{MD} Marque déposée de Sears Brands, LLC

© Sears Brands, LLC