

This Owner's Manual is provided and hosted by [Appliance Factory Parts](#).



MASTERCRAFT MTHC-20JSTD Owner's Manual

[Shop genuine replacement parts for MASTERCRAFT
MTHC-20JSTD](#)



[Find Your MASTERCRAFT Floor Machine Parts - Select From 34 Models](#)

----- Manual continues below -----



MTHC-20J-230 MULTI-PURPOSE FLOOR SURFACING MACHINE SAFETY & MAINTENANCE MANUAL W/PARTS LIST

Mastercraft

Address

Parts and Service Center
777 South Street
Newburgh NY 12550-0606

Phone

845/565/6623

Fax

845/565/8894

**READ & FOLLOW ALL INSTRUCTIONS,
WARNINGS & CAUTIONS
BEFORE USING THIS
FLOOR SURFACING MACHINE**

This unit is intended for commercial use.

This floor surfacing machine will afford you many years of trouble free operating satisfaction if it is given proper care. All parts have passed rigid quality control standards before being assembled to produce the finished product. Prior to packaging, the units are again inspected for assurance of flawless operation.

This floor surfacing machine was protectively packed to prevent damage in shipment. We recommend that upon delivery, remove the unit from its carton and carefully inspect it for any possible damage in transit. A warranty card is affixed to the handle. It is your responsibility to fill it out and send it to our office to register your purchase and start your warranty. Failure to send us this card in one week upon receipt of the machine may void the warranty.

If damage is discovered, immediately notify the transportation company that delivered your floor machine. As a shipper, we are unable to act upon any claim for concealed damage. You must originate any claim within 5 days of the delivery.

These instructions are for your protection and information. **PLEASE READ CAREFULLY!** Failure to follow these precautions could result in injury or discomfort.

Treat this floor surfacing machine as you would any other high grade precision made product. Throwing, dropping, unreasonable bumping across thresholds and other misuse may result in a damaged unit and invalidate the warranty.

**PLEASE READ
CAREFULLY
BEFORE
OPERATING**

SAVE THESE INSTRUCTIONS

IMPORTANT SAFETY INSTRUCTIONS



WARNING:

To reduce the risk of fire, electric shock or injury;
Read all instructions before using this floor machine.

- 1) **DO NOT** leave the floor surfacing machine plugged in when not in use. Unplug from the outlet when not in use and/or before servicing.
 - 2) Electric shock could occur if exposed to rain. Store indoors.
 - 3) This is **NOT** a toy. Close attention is necessary when used around or near children.
 - 4) Use only as described in this manual. Use only the manufacturer's recommended attachments.
 - 5) **DO NOT** use with damaged cord plug. If the floor machine is not working as it should because it has been dropped, damaged, left outdoors, or dropped into water, contact the manufacturer or authorized service center.
 - 6) **DO NOT** pull or carry by cord, use power cord as a handle, close a door on cord, or pull cord around sharp edges or corners. **DO NOT** run floor machine over the cord. Keep cord away from heated surfaces.
 - 7) **DO NOT** handle the plug or operate with wet hands.
 - 8) **DO NOT** put any object into motor openings.
 - 9) **DO NOT** unplug by pulling on cord. To unplug, grasp plug, not the power cord.
 - 10) Keep hair, loose clothing, fingers and all parts of body away from moving parts.
 - 11) **DO NOT** use an optional vacuum without the manufacturer's filters in place.
 - 12) **DO NOT** operate where anesthetics and oxygen are used.
 - 13) **DO NOT** use around flammable or combustible liquids such as gasoline or use in areas where they may be present.
 - 14) **DO NOT** use an extension cord.
 - 15) Replace damaged or worn parts immediately with genuine equipment parts to maintain safety and protect your limited warranty.
 - 16) Floor sanding can result in an explosive mixture of fine dust and air. Use a floor sanding machine only in a well ventilated area.
 - 17) **DO NOT** to leave sawdust in the filter bag when sander is not in use, this is a fire hazard.
- This floor machine must be connected to a properly grounded outlet only.

GROUNDING INSTRUCTION



DANGER:

Improper use of the grounding plug can result in a risk of electrical shock.

This floor surfacing machine must be grounded. If it should malfunction or breakdown, grounding provides a path of least resistance for electrical current to reduce the risk of electric shock. This machine is equipped with a

cord having an equipment-grounded plug. The plug must be inserted into an appropriate outlet that is properly installed and grounded in accordance with all local codes and ordinances

WARNING:



Improper connection of the equipment-grounding conductor can result in a risk of electrical shock. Check with a qualified electrician or service person if you are in doubt as to whether the outlet is properly grounded. **DO NOT** modify the plug provided with the machine. If it will not fit the outlet, have a proper outlet installed by a qualified electrician.

NOTE: In Canada, the use of a temporary adaptor is not permitted by the Canadian Electrical Code.



CAUTION:

When installing or changing the accessories, turn OFF the machine and disconnect the power cord from the electrical outlet.



Before Installation or Changing of Attachments:

- 1) Unplug the machine from the wall outlet.
- 2) Ensure handle is in the storage position (straight up) and locked in place with the quick release pin.
- 3) Tilt machine back by bracing it with your foot until the handle is laying on the floor and the three heads are fully exposed.

Note: It is recommended that a towel or pad is placed under the machine to protect the floor.



Changing and Installation the Attachments:

- 1) Position the first attachment head at 12 o'clock.
- 2) Using both hands, reach beneath the bottom side the attachment and pull up towards yourself to free it from the sander.
- 3) Select the attachment required for the job, and line up the holes on the attachment with the four metal pins protruding from each of the three heads.

ATTACHMENT INSTALLATION & CHANGING

- 4) Push the attachments on by hand and if necessary, carefully tap it into place with a rubber mallet.
- 5) Repeat steps 1 thru 4 with the remaining 2 attachments.
- 6) Carefully raise the handle, supporting the axle with your foot to control the head of the machine as it is placed on the floor.
- 7) Since the attachments are different heights you may need to adjust the dust skirt to make sure it is level with the attachments. This will ensure clean and virtually dust-free operation.
- 9) To adjust skirt, align the skirt with the center of the machine and wrap it around.
- 10) Move the handle back to the operating position and lock in place with the quick release pin.



CAUTION:

DO NOT attempt to operate this unit if the machine is not fully assembled.
When servicing or replacing an accessories turn OFF the machine and disconnect from the power source.
Prior to operating the machine, tilt machine back on transport wheels, turn ON the machine and carefully lower the machine onto the working surface.

- 1) Clear the floor of any materials or objects.
- 2) Ensure handle is in the storage position (straight up) and locked in place with the quick release pin.
- 3) Tilt the machine back until the handle is laying on the floor and the three heads are fully exposed.
- 4) Select the accessory set required for the job.
- 5) Snap the accessory set onto the four metal pins protruding from each of the three heads.
- 6) To replace, pull off the current accessory set and replace with the new accessory set.
- 7) Carefully raise the handle, supporting the axle with your foot to control the machine head as it is placed on the floor.
- 8) Shift handle to the operating position and lock in place with the quick release pin.

FLOOR SURFACING MACHINE OPERATING INSTRUCTIONS

MTHC-20J-230

HANDLE/BASE

ASSEMBLY

DRAWING &

PARTS LIST

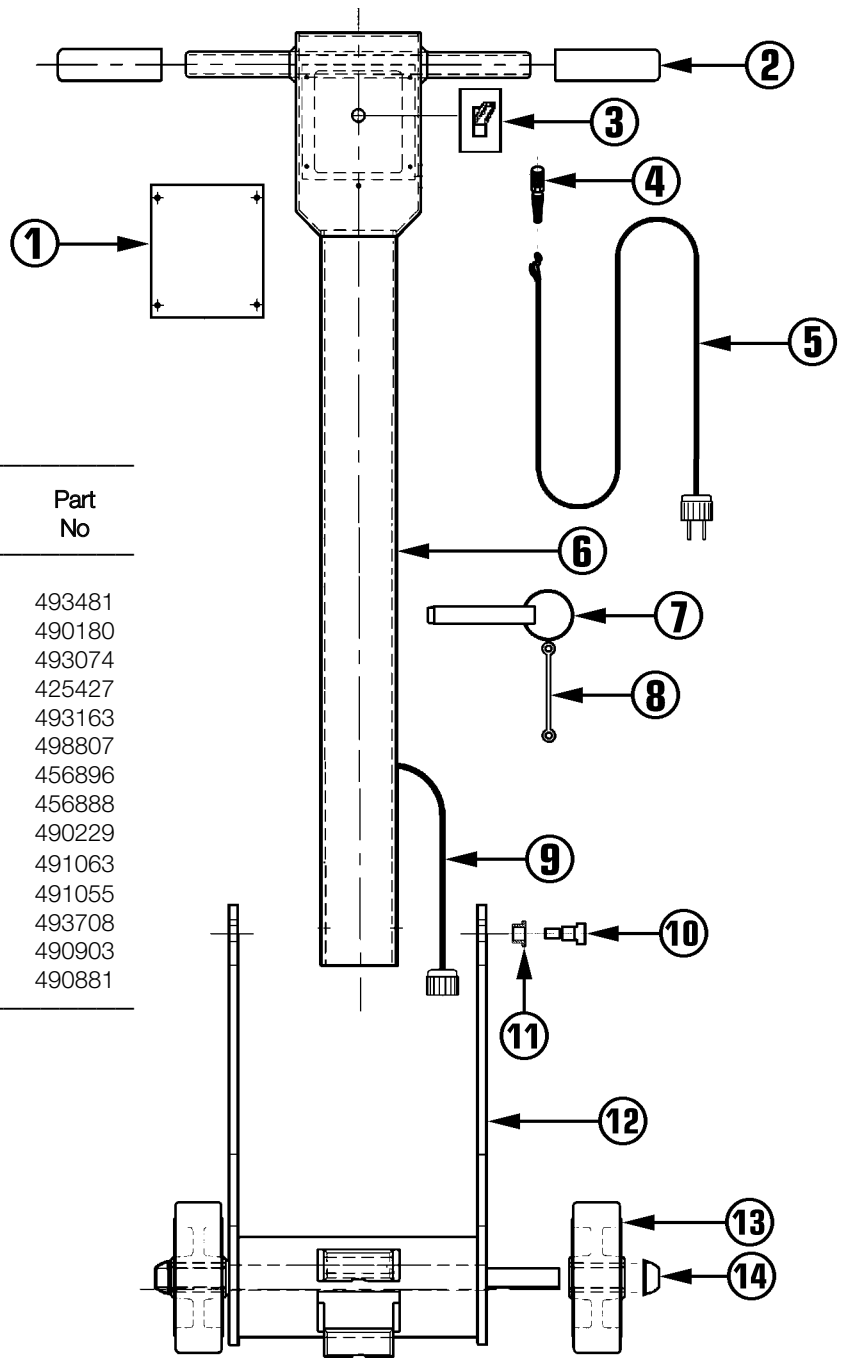

Ref No	Part Description	Qty	Part No
1	Switch Box Plate	1	493481
2	Rubber Handle Grip	2	490180
3	Machine Switch	1	493074
4	Strain Relief Assembly	1	425427
5	50 Ft Power Cord w/Twist Lock	1	493163
6	Handle Assembly	1	498807
7	Quick Release Pin w/Cable	1	456896
8	Wire Retainer	1	456888
9	Motor Cord without Plug	1	490229
10	.37-16 X 1/2" Shoulder Bolt	2	491063
11	Bronze Bushing	2	491055
12	Wheel Base Assembly	1	493708
13	6" X 2" Wheel	2	490903
14	Palnut	2	490881

MTHC-20J-230 OUTERBOWL ASSEMBLY DRAWING & PARTS LIST

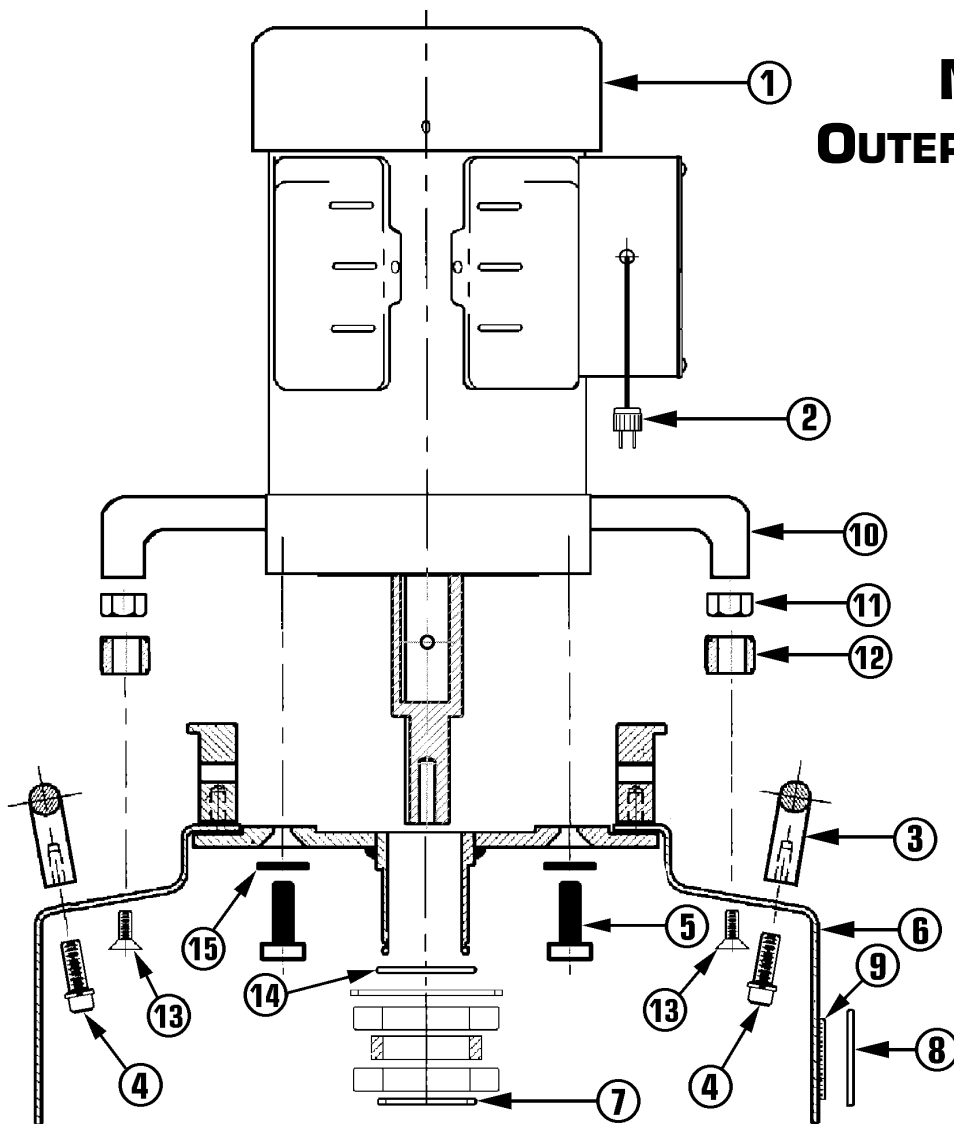

Ref No	Part Description	Qty	Part No
1	3 HP Motor, 3450 RPM's	1	491845
2	Pigtail	1	495786
3	Bowl Handle	2	490385
4	1/4-20 X 5/8" Screw	4	457310
5	.38-16 X 1" Bolt	4	368830
6	20" Outer Bowl Assembly	1	496464
7	13/4" External Snap Ring	1	491292
8	Rubber Dust Skirt	1	491926
9	Velcro Strip	1	492019
10	28# Weight (Optional)	1	492442
11	Nyloc Nut	3	380784
12	Weight Knob	3	491632
13	1/4-20 X .75" Screw	3	342831
14	Felt Gasket	1	493066
15	.37 Lockwasher	4	368849

MTHC-20J-230

INNERBOWL

ASSEMBLY

DRAWING

& PARTS LIST

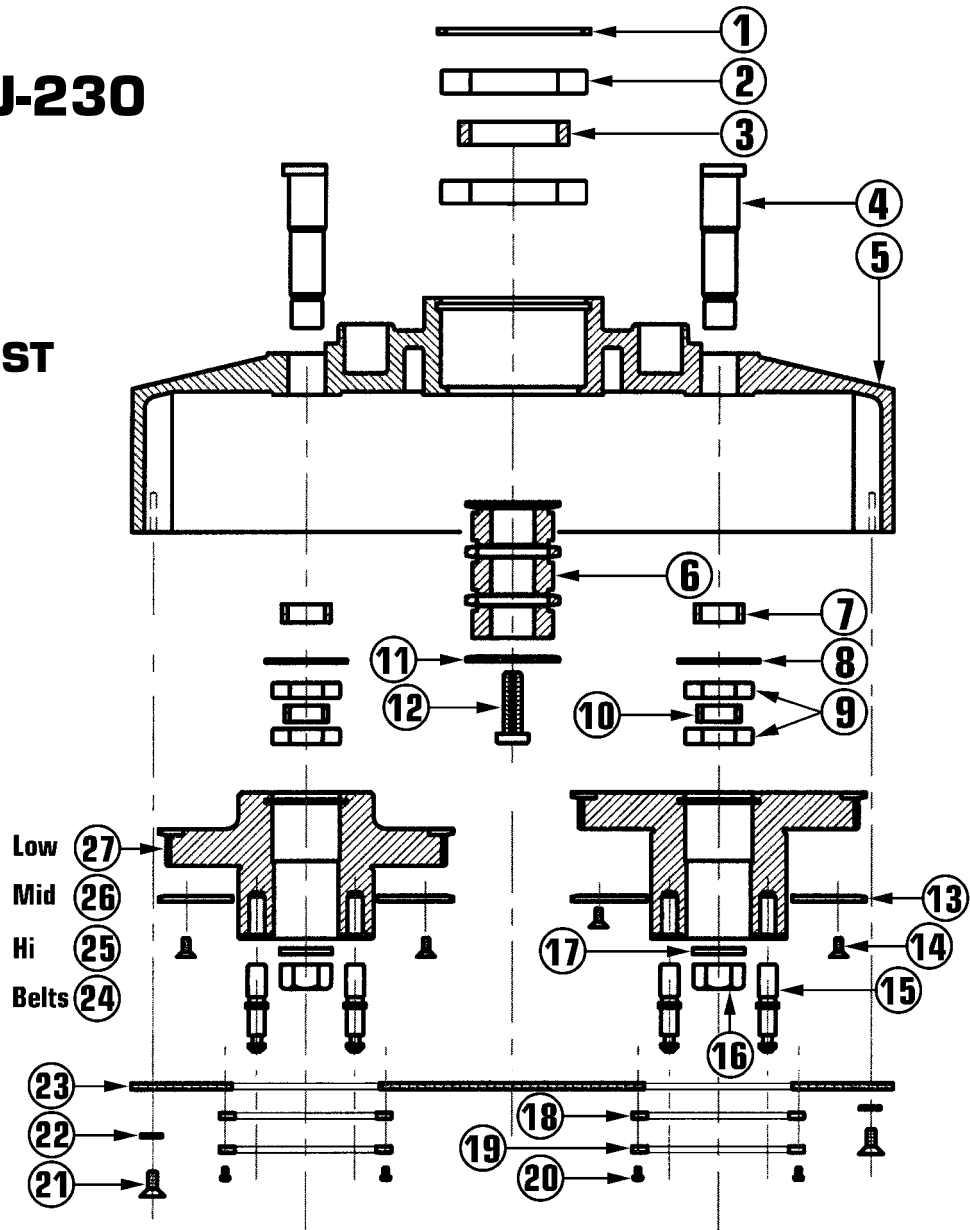

Ref No	Part Description	Qty	Part No	Ref No	Part Description	Qty	Part No
1	27/8 Internal Snap Ring	1	490598	15	Accessory Pins	12	490458
2	Bearing (6009-2RS)	2	490563	16	.62-11 Nylock Nut	3	490628
3	Large Bearing Spacer	1	490571	17	Washer	3	490636
4	Outer Pulley Shaft	3	490547	18	Felt Gasket	3	491373
5	20" Inner Bowl	1	491810	19	Aluminum Ring	3	490652
6	Center Cog Pulley	1	494836	20	Pop Rivet	12	456918
7	Shaft Spacer	3	490555	21	.25-20 x .5 Phillips Screw	9	331740
8	1 1/2 Internal Snap Ring	3	490466	22	#14, .43"OD Lockwasher	9	491012
9	Ball Bearing w/Seals	6	464910	23	Aluminum Cover Plate	1	491888
10	Small Bearing Spacer	3	490474	24	Belt (240-L050)	3	491918
11	Flange	1	490989	25	48 High Tooth Pulley	1	490512
12	Low Profile Bolt	1	490997	26	48 Middle Tooth Pulley	1	490490
13	3" ID x 6" OD Ring	3	222828	27	48 Low Tooth Pulley	1	490415
14	#10-32 x .5 Phillips Screw	9	377201				



WARNING:

IF THIS FLOOR MACHINE IS USED FOR SANDING, DO NOT LEAVE SAWDUST IN THE FILTER BAG WHEN THE MACHINE IS NOT IN USE. THIS IS A FIRE HAZARD.

This machine can be used with a variety of vacuums to pick up wood and concrete dust.

Operation of the vacuum cleaner must be in accordance with specific manufacturer's safety & operation instructions.

Recommend separate dedicated power source for machine and vacuum.

The vacuum hose must be attached to the 1 1/2" hose barb on the outer bowl of the floor machine.

During operation, periodically check the vacuum. When the cloth or paper filter bag is 3/4 full or dust is forming around the bottom of the machine, it MUST be emptied.

VACUUM OPERATING INSTRUCTION

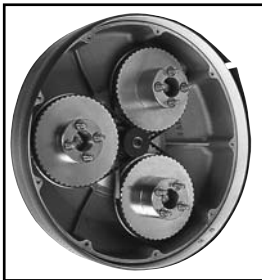

1) Unplug the motor power cord from the handle.

2) Pull the speed pin from the handle and remove the handle. Carefully set aside the handle.

3) Turn sander chassis upside down on a table resting on the motor cover.

4) Remove pads/attachments (see page 3 for instructions.)

5) Remove the 9 Flat head screws and beveled washers from cover plate.

6) Remove the cover plate from inner bowl.

7) Vacuum up the dust and debris from inner bowl.

8) Remove the old belt or belts by pulling upwards and roll off using a screwdriver while turning the pulley.

9) Roll new belt or belts back on the pulley.

10) Reassemble the machine reversing the above steps.

BELT CHANGING INSTRUCTIONS



CAUTION:

This machine is designed for surfacing concrete and sanding wood floors. All operators and maintenance personnel should read and understand the safety procedures with this floor machine.

1) All personnel in the immediate work area must wear safety glasses with side shields whenever the machine is in operation. Protective clothing is also recommended. Long sleeve shirts and safety shoes should be worn. Avoid wearing loose clothing.

2) **DO NOT** attempt to service or replace attachments while the machine is running or connected to a power source.

3) **DO NOT** operate this machine in the rain or in areas where liquids could enter the electrical components of the machine.

4) Keep the power cord away from the revolving heads to avoid damage.

5) Check the main power supply to assure that you are connecting the equipment to a proper dedicated service.

GENERAL SAFETY PRECAUTIONS

1) Unplug the machine.

2) After each use, wipe off machine with a clean cloth.

3) Empty the vacuum you are using in accordance with specific manufacturer's safety & operation instructions.

5) Check for loose parts and fasteners.

6) Check the power cord for any breaks in the wire. Breaks will most likely occur near the plug or switch. Repair or replace any breaks immediately.

MACHINE MAINTENANCE

TROUBLE SHOOTING GUIDE

PROBLEM: Motor will not run.

Possible Cause

- 1) Defective switch.
- 2) Defective power cord or wiring.
- 3) Defective motor.
- 4) Blown fuse or tripped circuit breaker at wall panel.
- 5) Power cord not plugged in properly or damaged.

Possible Solution

- 1) Check switch, replace if defective.
- 2) Check and replace if defective.
- 3) Have motor checked by an authorized service center.
- 4) Replace fuse or reset circuit breaker. If this doesn't correct the problem, have the sander checked by an authorized service center.
- 5) Plug in power cord properly or replace power cord if damaged.

PROBLEM: Machine bogs down and runs slow.

Possible Cause

- 1) Defective capacitor or switch.
- 2) Circuit may be overloaded with more than one appliance.
- 3) Low line voltage in building.

Possible Solution

- 1) Have machine checked by an authorized service center.
- 2) Plug floor machine into a dedicated power outlet. If the problem still exists there could be a short. Have the floor machine checked by an authorized service center.
- 3) If wiring is old in the building have voltage checked by the power company.

PROBLEM: Motor runs, driver will not rotate.

Possible Cause

- 1) Belts are broken.

Possible Solution

- 1) Contact the manufacturer or authorized service center.

PROBLEM: Noisy machine or vibration.

Possible Cause

- 1) Defective motor.
- 2) Attachment is not level or securely attached.

Possible Solution

- 1) Contact the manufacturer or authorized service center.
- 2) Level attachment and make sure all fasteners are secure.

WARRANTY

This machine is warranted against defects in material and workmanship for 1 year, except for normal wear items listed below, from the date of delivery to the original purchaser. The warranty period is subject to the conditions below:

Normal Wear Item

Warranted Up to 90 Days:

Normal wear items will be warranted from manufacturing defects from date of purchase including but not limited to the following items:

Accessories; Attachments; Belts; Bearings; Casters; Electric Cords; Finishes; Filters; Pad Holder; Switches; and the like.

Warranty is NULL and VOID for the following:

- 1) Damage, defects, malfunctions or other failures caused by not using the electric current indicated on the spec plate.

2) Damage or defect caused by accident; misuse; neglect; abuse; fire; etc.

4) Failure due to lack of proper maintenance and care (including cleaning).

5) Any unauthorized design alterations, adjustments and/or repairs performed on this machine.

6) Use of parts not approved by the machines manufacturer will void all warranties.

7) Damage in transit.

Stated Warranties

This Warranty is in lieu of and excludes all other warranties expressed or implied. Any statutory implied warranties, including the warranty of merchantability or fitness for a particular purpose, are expressly excluded. We will not be liable for any other damage including but not limited to indirect or spe

cial consequential damages arising out of or in connection with the furnishing, performance, use or inability to use the machine. This remedy shall be the exclusive remedy of the buyer. The warranty is limited to the warranty.

Warranty Claim Procedure

If a difficulty develops during the warranty period, contact the authorized distributor from whom the unit was purchased. The Warrantor may elect to require the return of the machine or components to validate the claim. any defective part to be returned must be properly packed and shipped freight pre-paid to an Authorized Distributor/Service Center.

Note: Because this machine is intended for commercial and/or industrial use the warranty is limited and not applicable to persons purchasing or using this equipment for personal, family or household use in which case the 90 day rule applies.