

This Owner's Manual is provided and hosted by [Appliance Factory Parts](http://www.appliancefactoryparts.com).

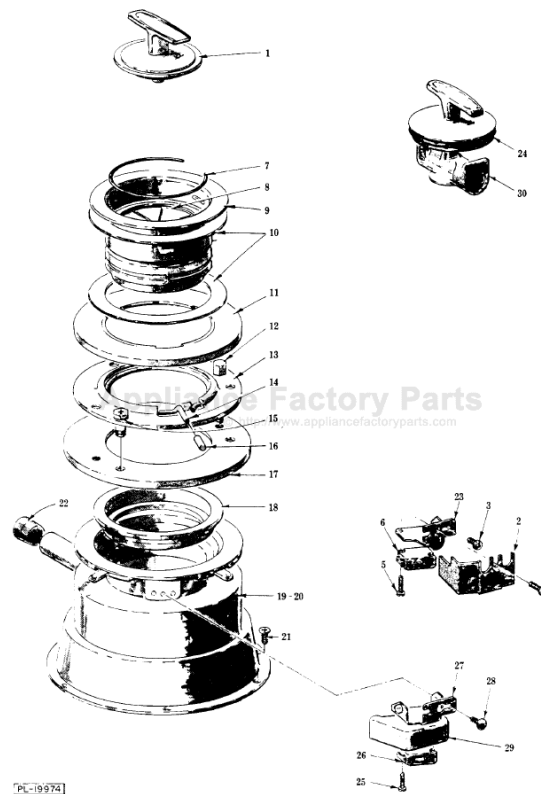

KITCHENAID KWD200 Owner's Manual

[Shop genuine replacement parts for KITCHENAID
KWD200](#)



[Find Your KITCHENAID Disposal Parts - Select From 75 Models](#)

----- Manual continues below -----

KitchenAid®
HEAVY DUTY
FOOD WASTE DISPOSERS

Models: Imperial KCDI200 (KWI-200A)

Electra KCDE200 (KWE-200A)

Superba KBDS200 (KWS-200A)

Deluxe KBDD200 (KWD-200A)

USE AND CARE GUIDE





IMPORTANT SAFETY INSTRUCTIONS

WARNING: When using electrical appliances, basic precautions should always be followed, including the following:

1. Read all instructions before using the disposer.
2. This disposer must be properly grounded. See Installation Instructions for details.
3. To reduce the risk of injury, close supervision is necessary when an appliance is used near children.
4. Do not put fingers or hands into a waste disposer.
5. Should the disposer appear to be jammed, follow the anti-jamming instructions in the Use and Care Guide. In the event that the disposer remains jammed, turn the power switch to the OFF position for the continuous feed models or remove the cover control of the batch feed models before attempting to manually clear a jam or remove an object from the disposer.
6. When attempting to manually loosen a jam in a waste disposer, use a long wooden object such as a wooden spoon or the wooden handle of a broom or mop.
7. When attempting to remove objects from a waste disposer, use long-handled tongs or pliers. If the disposer is magnetically actuated, non-magnetic tools should be used.
8. To reduce the risk of injury by materials that may be expelled by a waste disposer, do not put the following into a disposer.
 - a. Clam or oyster shells
 - b. Drain cleaner
 - c. Glass, china or plastic
 - d. Large, whole bones
 - e. Metal, such as bottle caps, tin cans or aluminum foil
 - f. Whole corn husks
9. When not operating a disposer, leave the drain cover in place to reduce the risk of objects falling into the disposer.

SAVE THESE INSTRUCTIONS



TABLE OF CONTENTS

	Page
Important Safety Instructions	2
Ownership Registration Card	3
Operating Instructions	4-5
What Can Be Put In Your KitchenAid Disposer	6
If Your Disposer Jams	6-7
Grounding Information	8
Care and Cleaning	8
When You Need Service	9
Warranty	Back Cover

OWNERSHIP REGISTRATION CARD

Before you use your disposer, please fill out and mail your ownership registration card. This card will enable us to contact you in the unlikely event of a product safety notification and assist us in complying with the provisions of the Consumer Product Safety Act. **THIS CARD DOES NOT VERIFY YOUR WARRANTY.**

Keep a copy of the sales receipt showing the date of purchase and/or date of installation of your disposer. **PROOF OF PURCHASE WILL INSURE YOU OF IN-WARRANTY SERVICE.**

Write down the following information. You will need it if your disposer ever requires service.

Model Number* _____

Serial Number* _____

Date Purchased _____

Date Installed _____

Dealer's Name _____

Address _____

Phone _____

*Model and Serial Numbers are located on a label near the bottom of the disposer.

OPERATING INSTRUCTIONS FOR CONTINUOUS FEED MODELS

KitchenAid Imperial Model
KitchenAid Electra Model

The Imperial and Electra continuous feed disposers have a one-piece cover that acts *only* as a seal. A wall switch is used to turn the disposer on or off.

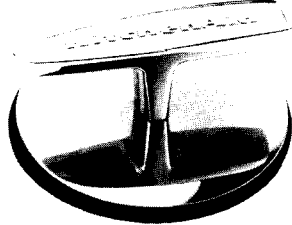

To SEAL the cover for holding water in the sink, press the cover firmly in the disposer opening. CAUTION: Do *not* operate the disposer with the cover in the SEAL position.

TO OPERATE:

1. Remove cover from sink opening and turn on a *good flow of COLD water*. (*Cold water hardens greasy substances, making it easy to grind them into tiny particles. Cold water also keeps grease from sticking to the drain lines.*) It is important and absolutely necessary that cold water flows into the disposer while it is in operation. If you have a double sink, make sure the faucet points to side where the disposer is installed.
2. Turn wall switch to ON position.
3. Scrape food waste into disposer opening. The splash guard will reduce splashing. Mix soft and hard food waste items for most efficient grinding.

4. Allow both the disposer and cold water to run for about 30 seconds after grinding action is completed. This will assure that any bone slivers or other hard objects that could cause jams are flushed from the grind chamber. This will also assure proper flushing of the external drain line.

5. Turn wall switch to OFF position.

OPERATING INSTRUCTIONS FOR BATCH FEED MODELS

KitchenAid Superba Model
KitchenAid Deluxe Model

The Superba and the Deluxe Models are batch feed disposers which operate when the MAGNESTART® Cover Control is in position, keeping food waste in and other objects from accidentally falling into the disposer during operation.

The patented MAGNESTART Cover Control has a magnet set into the base. The position of the magnet is indicated by an arrow surrounding the word KitchenAid on the handle. When the Cover Control is placed in the proper position in the sink opening, the magnet actuates a switch and the disposer starts.

POSITIONS OF THE COVER CONTROL

Grind Position: Looking into the sink opening, you will see two sets of "V" grooves stamped into the upper housing. These grooves support the cover for operation. Note the red arrow in one set of the "V" grooves. Point the MAGNESTART Cover Control arrow to the red arrow in the sink opening and drop in place. **Do not rotate cover control.** In this position—the Grind Position—nothing but water can enter the grinding chamber and the disposer will start.

Seal Position: To seal the sink so that it will retain water, point MAGNESTART Cover Control *between* the two sets of "V" grooves and drop in place.

Drain Position: To drain the sink, point MAGNESTART Cover Control arrow to set of "V" grooves opposite those with the red arrow and drop in place. **When disposer is not in use, the MAGNESTART Cover Control should be kept in DRAIN Position to keep foreign objects from dropping into the unit.**

TO OPERATE:

1. Remove MAGNESTART Cover Control and scrape food waste into disposer

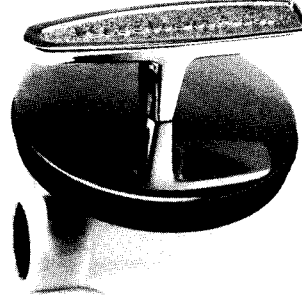

opening. Mix soft and hard food waste items for most efficient grinding.

2. Turn on a *good flow of COLD water.* (*Cold water* hardens greasy substances, making it easy to grind them into tiny particles. *Cold water* also keeps grease from sticking to the drain lines.) It is important and absolutely necessary that cold water flows into the disposer while it is in operation. If you have a double sink, make sure the faucet points to side where the disposer is installed.

3. Place MAGNESTART Cover Control in GRIND Position to start disposer. **Do not rotate cover control.**

4. Allow both the disposer and cold water to run for about 30 seconds after grinding action is completed. This will assure that any bone slivers or other hard objects that could cause jams are flushed from the grind chamber. This will also assure proper flushing of the external drain line.

5. Lift MAGNESTART Cover Control to stop disposer—**Never rotate cover control.**



WHAT CAN BE PUT IN YOUR KITCHENAID DISPOSER?

Your disposer is designed to dispose of food wastes including bones, fruit and vegetable wastes, pits, egg shells and coffee grounds. Large pieces of food waste like melon rinds should be cut into smaller pieces before being put into the disposer.

If the disposer drains into a septic tank, grinding wastes such as egg shells, lobster, crab and shrimp shells should be kept at a minimum. Grinding large amounts of this type of waste may require more frequent cleaning of the septic tank system.

DO NOT PUT ITEMS LIKE GLASS, CHINA, METAL, TIN CANS, BOTTLE CAPS OR OYSTER AND CLAM SHELLS INTO THE DISPOSER. THESE ITEMS BELONG IN THE TRASH. DAMAGE MAY RESULT TO BOTH DISPOSER AND DRAIN SYSTEM IF THIS TYPE OF TRASH IS PLACED IN A DISPOSER.

IF YOUR DISPOSER JAMS

JAMS OF ANY NATURE ARE NOT CONSIDERED A PRODUCT DEFICIENCY AND ARE NOT COVERED BY IN-WARRANTY SERVICE OR LABOR.

If your disposer appears to be jammed—the grind wheel in grind chamber does not turn freely—check the following procedure for each model before calling your dealer and possibly save the cost of a service call.

NOTE: *If disposer remains jammed for longer than 30 seconds, a built-in overload protector will turn disposer off. See instructions below for Built-in Overload Protection.*

Each time the disposer is operated, the grind wheel moves in the opposite direction for greater efficiency and longer grinding element life. Should the disposer become jammed, the reversing action will help clear the jam. See below.

Superba and Deluxe models—For ordinary jams, lift Control Cover momentarily, replace in GRIND position; repeat several times if necessary to clear jam.

Imperial and Electra models—Flip the wall switch off and on. Repeat several times if necessary to clear the jam.

BUILT-IN OVERLOAD PROTECTION

KitchenAid Disposers are equipped with built-in overload protection. If disposer is jammed for more than 30 seconds, an overload protector automatically cuts off current to the motor, preventing motor damage. The protector on the Superba and Deluxe models automatically resets after the motor cools. On Imperial and Electra models, wait 3 to 5 minutes, then press the red reset button on the bottom of the disposer. If disposer has been running for an extended period of time you may have to wait 20 to 25 minutes for the motor to cool, before pressing the reset button. **PRESS THIS BUTTON FIRMLY UNTIL IT CLICKS.**

FOR MORE DIFFICULT JAMS, BOTH THE SUPERBA AND IMPERIAL MODELS HAVE THE EXCLUSIVE WHAM JAM BREAKER.



The WHAM JAM BREAKER uses a solid state control to vibrate the grind wheel back and forth 7200 times per minute. This will eliminate almost any jam instantly.

When a difficult jam occurs, follow these steps.

SUPERBA MODEL Make sure cover control is in GRIND position. Disposer should now be “humming.” Press the WHAM JAM BREAKER button on the front side of disposer and release—DO NOT HOLD. If the disposer is still jammed, repeat pressing and releasing the WHAM JAM BREAKER button until the disposer runs. If the disposer is jammed too long (approximately 30 seconds), the thermal overload protector will stop the motor (the motor will not hum). After 3 to 5 minutes the motor will cool and the thermal overload protector will reset automatically.

IMPERIAL MODEL Make sure the wall switch is in the “ON” position and the disposer “humming.” Press the WHAM JAM BREAKER button on the front side of the disposer—DO NOT HOLD. If the disposer is still jammed, repeat pressing and releasing the WHAM JAM BREAKER button until the disposer runs. **If the disposer does not hum with the wall switch in the “ON” position, wait 3 to 5 minutes and firmly press the red reset button on the bottom of the disposer until it clicks.** See **BUILT-IN OVERLOAD PROTECTION**, page 6. The disposer should now hum.



OPERATION WITH DISHWASHER

If your dishwasher drains through your disposer run the disposer for a short time before starting the dishwasher. This will insure that the disposer is free of any unground food waste. Such waste could cause a "backup" of the discharge water from the dishwasher. **DO NOT OPERATE THE DISPOSER WHILE THE DISHWASHER IS IN OPERATION.** After operating the dishwasher, run the disposer for a short time to clean and flush all particles discharged by the dishwasher into the disposer down the main drain line.

When the dishwasher is in operation, we recommend the cover be placed in the DRAIN position. This will eliminate the possibility of water splash out.

GROUNDING INFORMATION

This appliance must be connected to a grounded, metal, permanent wiring system; or an equipment-grounding conductor must be run with the circuit conductors and connected to the equipment-grounding terminal or lead on the disposer. For detailed instructions see Installation Instructions.

ALL ELECTRICAL CONNECTIONS MUST CONFORM WITH LOCAL CODES.

This disposer is Listed by Underwriters Laboratories, Inc.

USE ENERGY WISELY

A food waste disposer uses a negligible amount of energy. Total energy requirements associated with operating a food waste disposer will be minimized by following the recommendations in this Use and Care Guide.

CARE AND CLEANING

The unique design of the grinding elements of the disposer create a whirling water action which keeps the grinding chamber always clean and free of odors.

Do not "store" food waste in the disposer between grindings. This can lead to odors, a clogged drain or a jam.

Use COLD water *only* when operating the disposer. Cold water hardens greasy substances, making it easy to grind them into tiny particles. Cold water also keeps grease from sticking to the drain lines.

CAUTION: NEVER use chemical or solvent drain compounds in the disposer. They can cause serious damage and are unnecessary if the disposer is operated according to the above instructions. If a drain cleaner is absolutely necessary, use one labeled "safe for disposers" or "enzymatic cleaner" like Rid-X.

Your KitchenAid disposer is permanently lubricated and will never need additional lubrication.

WHEN YOU NEED SERVICE

Follow These Steps

1. If your disposer should fail to operate, CHECK the following list before calling your dealer. *Save the cost of a service call* because the following situations are not covered by the warranty.
 - Jammed grind wheel? Make sure the grind wheel is free to rotate.
 - Blown fuse? Check your fuse or circuit breaker box.
 - Imperial and Electra models—is switch controlling the disposer turned on?
 - Superba and Deluxe models—is cover control in “grind” position?
 - Tripped motor overload protector? Please see Built-in Overload Protection Instructions, page 6.
 - Have you read your Use and Care Guide for complete instructions?
2. If the problem is not due to one of the above items, see “How to arrange for Service” listed in the Warranty Statement.
3. If you are not satisfied with the action taken, contact the Major Appliance Consumer Action Panel (MACAP). MACAP is a group of independent consumer experts that voices consumer views at the highest levels of the major appliance industry. Contact them only when the dealer, au-

thorized servicing outlet and KitchenAid, Inc., have failed to resolve your problem.

Major Appliance Consumer
Action Panel
20 North Wacker Drive
Chicago, IL 60606

MACAP will in turn inform us of your action.

In all correspondence about your dishwasher, please include:

- Date
- Your Name, Address and Telephone Number
- Type of Appliance
- Brand
- Model Number
- Serial Number
- Date Purchased
- Dealer from Which Purchased (include address)
- Servicing Agent (include name and address if different from dealer's)
- Location of Appliance
- A Clear Description of the Problem and the Service Required.

KITCHENAID® DISPOSER WARRANTY

LENGTH OF WARRANTY:	KITCHENAID WILL PAY FOR:	KITCHENAID WILL NOT PAY FOR:
ONE YEAR FULL WARRANTY FROM DATE OF INSTALLATION FOR MODELS: KCDE200 (KWE-200A) KBDD200 (KWD-200A)	Replacement parts and repair labor to correct defects in materials or workmanship. Service must be provided by a KitchenAid authorized servicing outlet.	A. Service calls to: 1. Correct the installation of the disposer. 2. Instruct you how to use the disposer. 3. Replace house fuses or correct house wiring. 4. Correct house plumbing.
FIVE YEAR LIMITED WARRANTY ONE YEAR FULL PLUS SECOND THROUGH FIFTH YEAR LIMITED FROM DATE OF INSTALLATION FOR MODELS: KCDE200 (KWE-200A) KBDD200 (KWD-200A)	Replacement parts (excluding decorative shell, cover control and any repair labor costs) if defective in materials or workmanship.	B. Repairs when dishwasher is used in other than normal home use. C. Damage resulting from accident, alteration, misuse, abuse, improper installation or installation not in accordance with local electrical and plumbing codes.
FIVE YEAR FULL WARRANTY FROM DATE OF INSTALLATION FOR MODELS: KBDS200 (KWS-200A) KCDI200 (KWI-200A)	Replacement parts and repair labor to correct defects in materials or workmanship. Service must be provided by a KitchenAid authorized servicing outlet.	D. Replacement parts cost for decorative shell or cover control during warranty. E. Any labor costs during limited warranty. F. Replacement parts or labor costs for units operated outside the United States.

KITCHENAID, INC., DOES NOT ASSUME ANY RESPONSIBILITY FOR INCIDENTAL OR CONSEQUENTIAL DAMAGES.

Some states do not allow the exclusion or limitation of incidental or consequential damages, so this exclusion or limitation may not apply to you.

This warranty gives you specific legal rights and you may also have other rights which vary from state to state.

HOW TO ARRANGE FOR SERVICE

- First call your dealer or authorized KitchenAid repair service he recommends.
- All service should be handled locally by the dealer from whom you purchased the unit or an authorized KitchenAid servicing outlet. If your

local service is not satisfactory, contact the Consumer Affairs Department, KitchenAid, Inc., 3800 Space Drive, Dayton, Ohio 45414. Telephone 800-422-1230.