

This Owner's Manual is provided and hosted by [Appliance Factory Parts](http://Appliance Factory Parts).

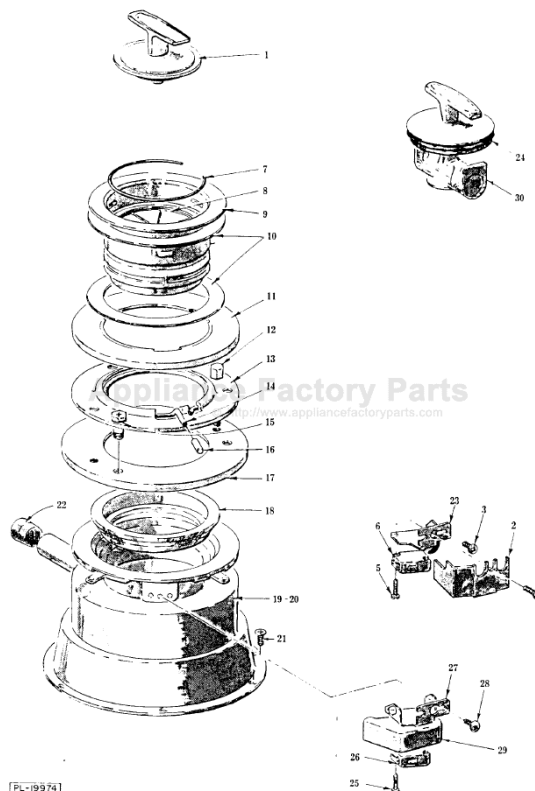

# KITCHENAID KWD200AE Owner's Manual

[Shop genuine replacement parts for KITCHENAID  
KWD200AE](#)



[Find Your KITCHENAID Disposal Parts - Select From 75 Models](#)

----- Manual continues below -----

*Catalog of*

# REPLACEMENT PARTS

**KitchenAid®**

## HEAVY DUTY DISPOSERS 230 VOLT, 50 HZ. MODELS

<u>ML</u>	<u>MODEL NO.</u> (CONTINUOUS FEED)	<u>SAME AS</u> <u>MODEL NO.</u>
42145	5KCDE200S	KWE-200AE
42147	5KCDI200S	KWI-200AE
42183	7KCDE200S	(NONE) U.K.
42182	7KCDI200S	(NONE) U.K.
	(BATCH FEED)	
42146	5KBDD200S	KWD-200AE
42144	5KBDS200S	KWS-200AE
42181	7KBDD200S	(NONE) U.K.
42180	7KBDS200S	(NONE) U.K.

KitchenAid Inc.

St. Joseph, Michigan 49085 U.S.A.

---

PART NO. 4171085

19-E-7

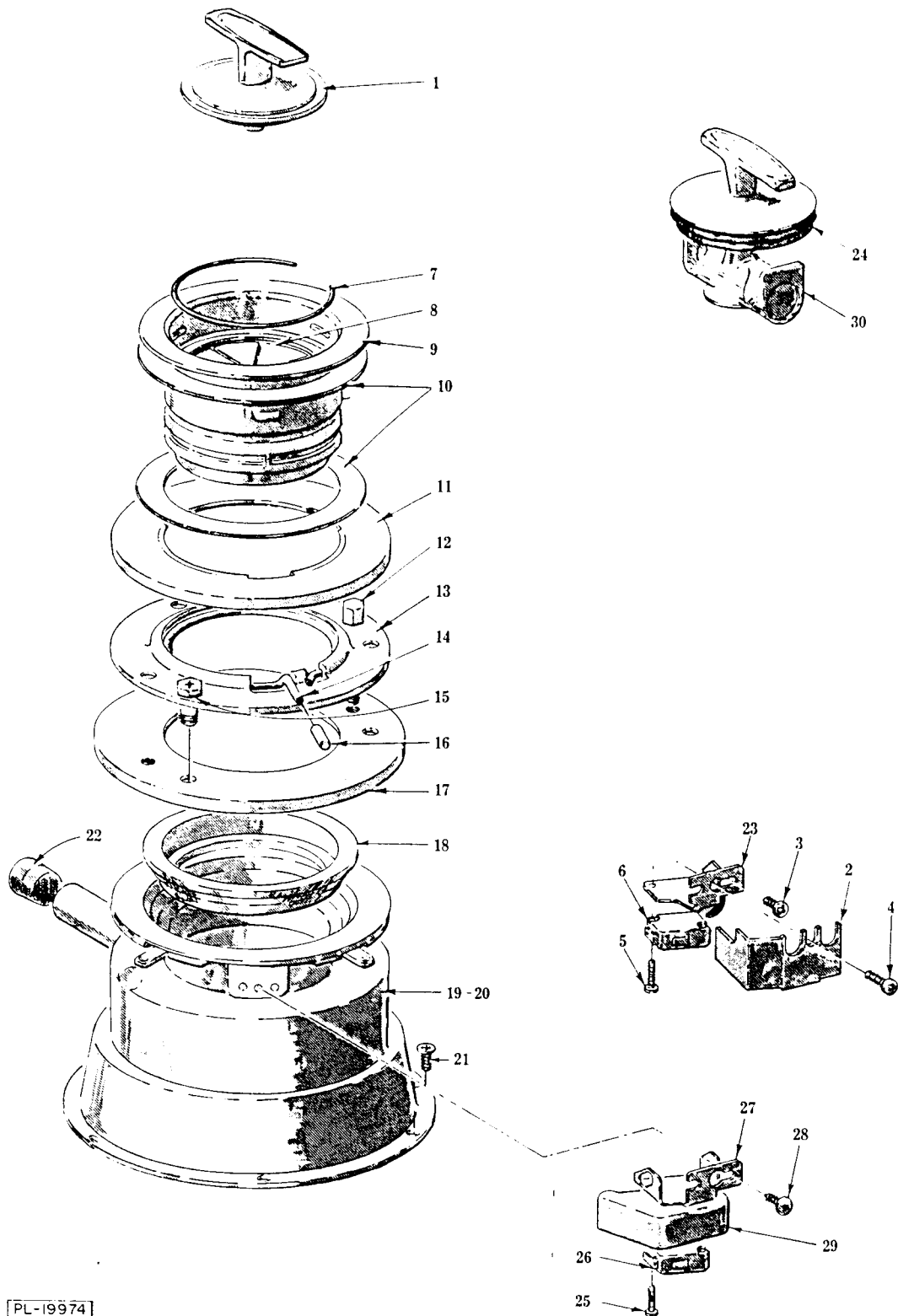

UPPER HOUSING UNIT

1	242915	Seal - Closure
2	241499	Cover - Switch
3	SD-32-23	Self-Tapping Screw 8 x 3/8 Phil. Pan Hd., Type B
4	SD-19-31	Self-Tapping Screw 8 x 1/2 Phil. Pan Hd., Type B
5	SD-9-14	Self-Tapping Screw 4-40 x 5/8 Phil. Pan Hd., Type F
6	241499	Switch & Magnet Assy
**7	114907	Ring - Splash Guard
**8	240871	Splash Guard Assy. (Incls. item 7)
9	114892	Flange - Sink
10	201462	Seal - Sink Flange
11	114898	Washer - Pressure
12	114897	Screw - Adjusting
13	114891	Ring - Support
14	116064	Snap Ring & Cap Assy. (Incls. item 16)
15	114909	Screw - Hold-Down
16	115803	Cap - Snap Ring
17	114899	Plate - Pressure
18	114905	Ring - Seal
*19	242295	Upper & Lower Housing Assy
*20	242296	Upper & Lower Housing Assy
21	SC-18-70	Mach. Screw 8-32 x 7/16 Phil. Pan Hd
22	242481	Plug - Drain (Dishwasher)
23	241499	Bracket - Switch Mounting
*24	241203	Seal - Cover
*25	SD-9-14	Self-Tapping Screw 4-40 x 5/8 Phil. Pan Hd., Type F
*26	241448	Switch & Magnet Assy
*27	241449	Bracket - Switch Mounting
*28	SD-9-39	Self-Tapping Screw 8-32 x 3/8 Phil. Pan Hd., Type B
*29	241449	Cover - Switch
*30	241251-1	Control Cover Assy. (Incls. item 24)

**242978	Closure Assy. (Incls. item 1)
*242761-2	Upper Housing Assy. (Incls. items 19 & 22)
**242761-1	Upper Housing Assy. (Incls. items 20 & 22)
*241449	Switch, Cover & Bracket Assy. (Incls. items 10, 25, 26, 27 & 29)

\*Use with Batch Feed Models \*\*Use with Continuous Feed Models

Note 1: Parts 2, 6 & 23 have been discontinued, order \*241499 to convert to new style.

Note 2: Order switch, cover & braket ass'y 241449

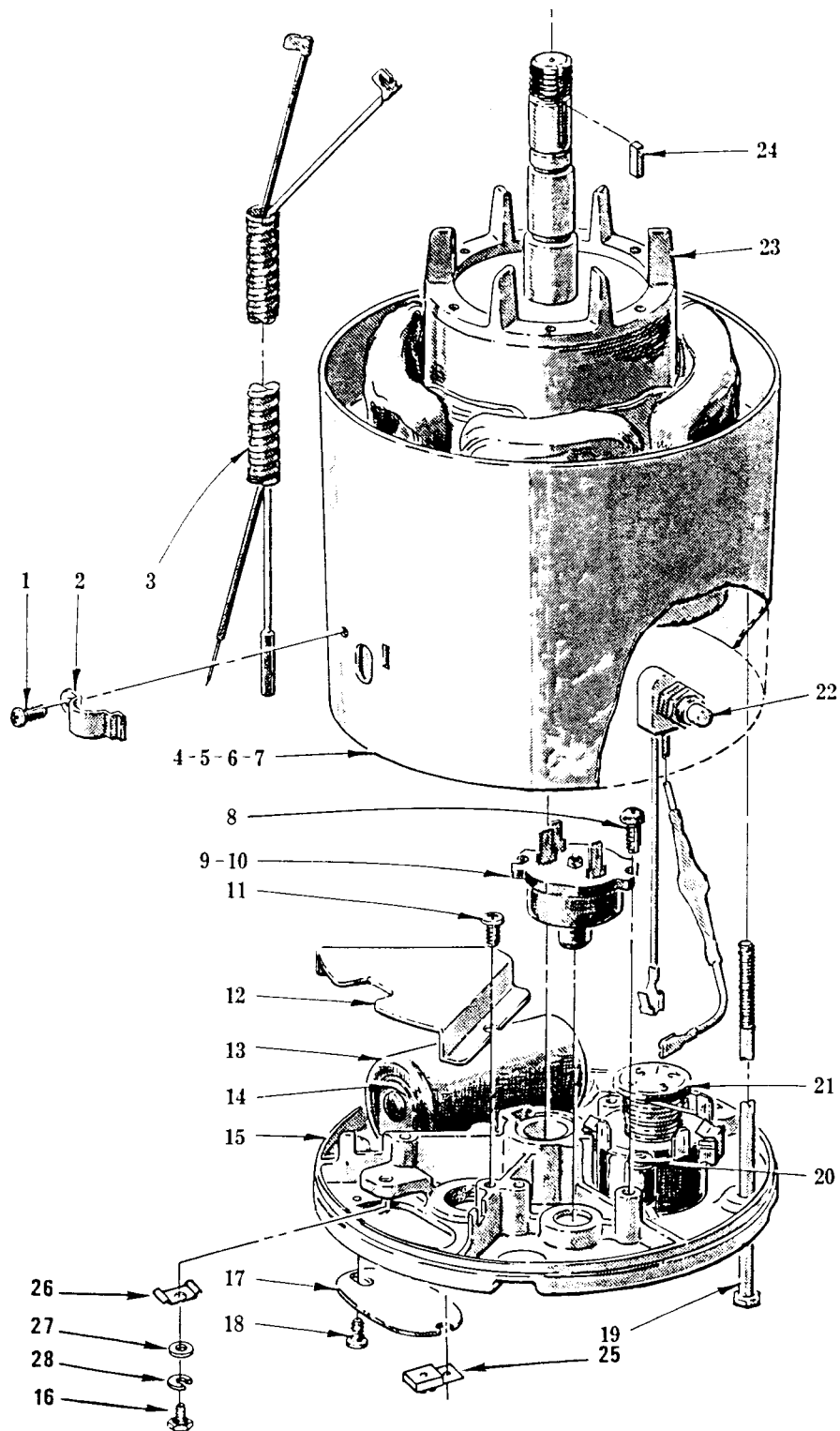

ELECTRICAL UNIT

1	SD-19-31	Self-Tapping	Screw 8 x 1/2 Phil. Pan Hd., Type B
*2	114911	Clamp - Conduit	
*3	240073	Conduit	Assy
**4	See Note	Stator Assy. ( 230 V, 50 Hz )	(KWE)
*5	See Note	Stator Assy. ( 230 V, 50 Hz )	(KWD)
**6	See Note	Stator Assy. ( 230 V, 50 Hz )	(KWI)
*7	See Note	Stator Assy. ( 230 V, 50 Hz )	(KWS)
8	278497	Screw Assy. (Protector)	
**9	201875	Protector - Overload (Manual)	(KWE/KWI)
*10	201876	Protector - Overload (Automatic)	(KWD/KWS)
11	SD-12-30	Self-Tapping, Screw 6-32 x 5/16 Phil. Pan Hd., Type T	
12	115314	Barrier - Elec. Enclosure	
13	70487-16	Capacitor	
14	108871	Clip - Capacitor Retainer	
15	240082	Bracket & Bearing Assy	
16	202559	Screw - Mach. Grounding	
17	109923	Cover - Elec. Access	
18	SD-12-30	Self-Tapping Screw 6-32 x 5/16 Phil. Pan Hd., Type T	
19	113690	Mach. Screw 10-32 x 5 5/8 Indented Hex Hd	
20	SD-33-37	Self-Tapping Screw 6-32 x 1 Phil. Pan Hd., Type T	
21	113657-4	Reversing Relay Assy.	
22	118107	Switch & Diode Assy. (KWI-200 & KWS-200X ONLY)	
23	See Note	Rotor Assy.	
24	240509	Key - Sq. Mach	
25	240083	Splice Connector	
26	240063	Terminal Clamp	
27	WS-28-18	Flat Washer	
28	WL-7-12	Lock Washer	

POWER PAK

4169565	Power Pak (230 V., 50 Hz.)	(KWE)
4169564	Power Pak (230 V., 50 Hz.)	(KWD)
4169563	Power Pak (230 V., 50 Hz.)	(KWI)
4169562	Power Pak (230 V., 50 Hz.)	(KWS)

\* Use on Batch Feed Models

\*\* Use on Continuous Feed Models

Note: Order Appropriate Power Pak

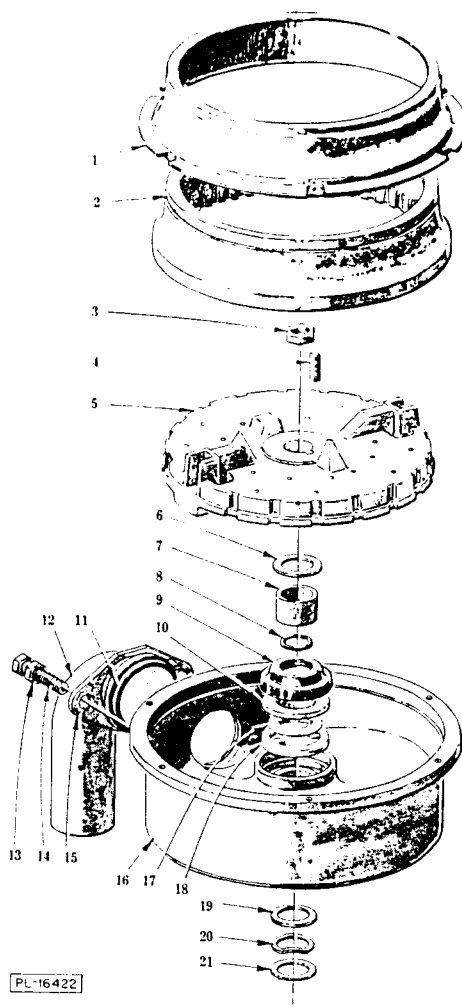

POWER UNIT

1	115804	Seal - Shredder Ring
2	242555	Ring - Shredder
3	NS-17-41	Jam Nut 5/8-18 Hex Fin
4	240290	Lock - Jam Nut
5	242556	Flywheel
6	202732	Washer - Wear
7	202927	Sleeve - Seal
8	201444-8	"O" Ring
9	201469	Seal - Water
10	115805	Felt (Lubricant)
11	115818	Seal - Spout
12	240094	Spout & Seal Assy. (Incls. item 11) (Brass)
13	NS-13-2	Full Nut 1/4-20 Hex Fin
14	115866	Screw - Special
15	241026	Flange - Spout
16	115511-1	Lower Housing & Bearing Assy
17	202734	Washer - Upper Thrust
18	240592	Felt Wiper Kit
19	WS-11-50	Washer (Nylon)
20	115461	Washer - Wavy
21	WS-11-49	Washer
	240593-1	Seal Kit (Incls. items 6, 7, 8, 9, 10 & 17 thru 21)
	240594-1	Seal & Lower Housing Kit (Incls. items 6, 7, 8, 9, 10 & 16 thru 21)
	201252	Spout Screw Assy. (Incls. items 13 & 14)
	242028	Flywheel Assy. Kit (Incls. items 5 & 6)

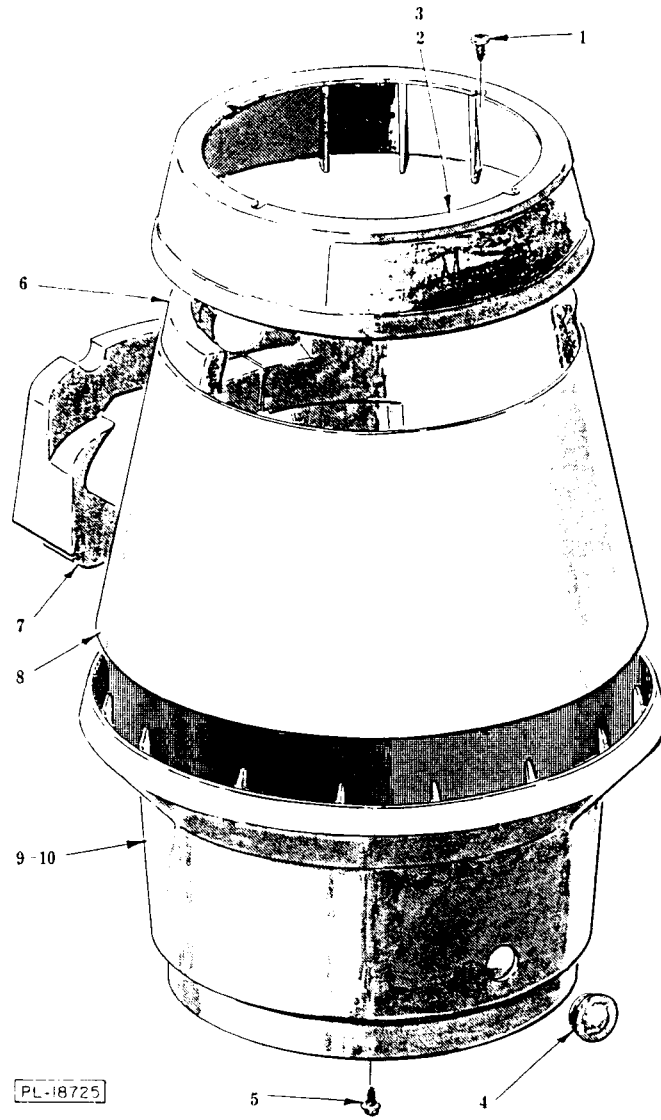

SHELL UNIT (KWI & KWS)

1	SD-15-41	Self-Tapping Screw 8-32 x 1/2 Phil. Pan Hd., Type TT
**2	242060-3	Cap - Top (KWI)
*3	243144	Top Cap & Label (KWS)
4	115409	Button - Anti-Jam
5	SD-12-32	Self-Tapping Screw 6-32 x 3/8 Indented Hex Washer Hd., Type T
6	115425	Insulation - Upper
7	115365	Liner - Drain
8	242024	Trim - Band Assy
*9	242119-3	Lower Shell & Label Assy. (KWS)
*10	242119-4	Lower Shell & Label Assy. (KWI)
	*242115-5	Cap, Shell & Trim Band Assy. (Incls. items 3, 8 & 9) (KWS)
	**242115-6	Cap, Shell & Trim Band Assy. (Incls. items 2, 8 & 10) (KWI)

\* Use on Batch Feed Models \*\* Use on Continuous Feed Models

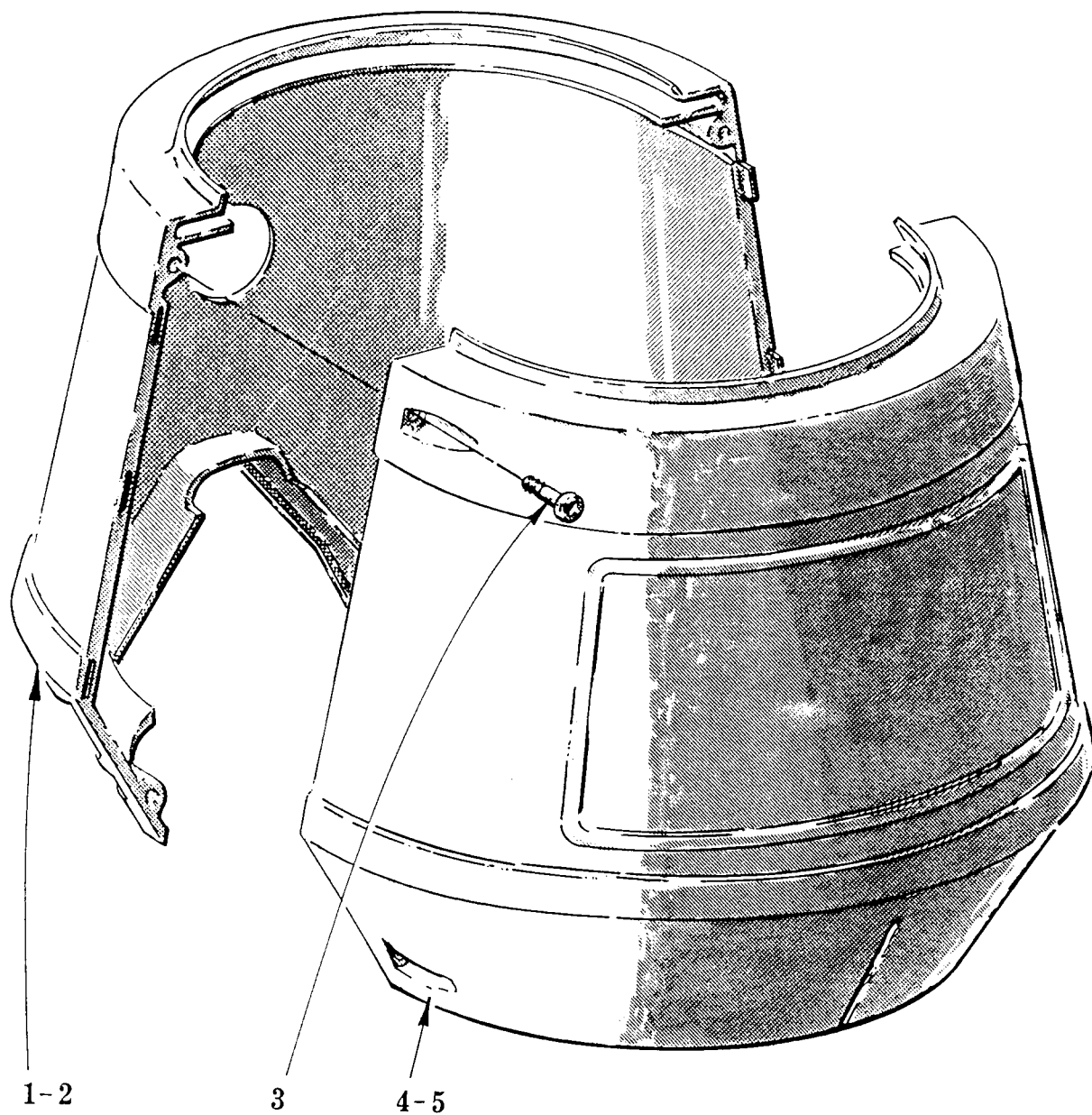

SHELL UNIT (KWD & KWE)

**1	115353-3	Shell - Rear (KWE)
*2	115352-3	Shell - Rear (KWD)
3	115369	Self-Tapping Screw 6-20 x 11/16 Phil. Pan Hd., Type B
**4	115669-6	Front Shell & Label (KWE)
*5	115669-5	Front Shell & Label (KWD)

\*Use on Batch Feed Models

\*\*Use on continuous Feed Models