

This Owner's Manual is provided and hosted by [Appliance Factory Parts](http://www.appliancefactoryparts.com).

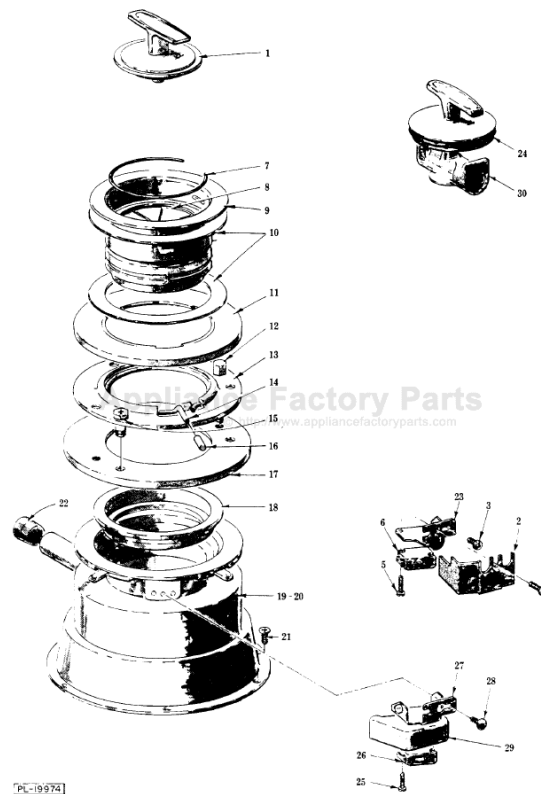

KITCHENAID KWI200A Owner's Manual

[Shop genuine replacement parts for KITCHENAID
KWI200A](#)



[Find Your KITCHENAID Disposal Parts - Select From 75 Models](#)

----- Manual continues below -----

KitchenAid.

HEAVY DUTY DISPOSERS

**MODELS KWE-200, KWI-200,
KWD-200, & KWS-200**

INSTALLATION INSTRUCTIONS

INSTALLER: FINAL CHECK LIST

GENERAL

- 1. Remove unit from carton and check for shipping damage.
- 2. Sink flange assembled in center of drain opening and flange seals in place to assure a water tight seal.
- 3. Disposer level – not installed at an angle.

PLUMBING

- 1. If installed in old house, existing drain line from sink to sewer cleaned.
- 2. Long, horizontal drain lines eliminated.
- 3. Drum traps and grease traps should not be used.
- 4. Seal at drain spout properly positioned.
- 5. Center line height of drain line must not exceed center line height of disposer discharge opening.
- 6. Mounting screws and spout screws properly tightened to prevent leaks.
- 7. Compliance with all aspects of local plumbing code.

ELECTRICAL CONNECTION

- 1. Properly fused, 115 volt, 60 hertz branch circuit of 15 ampere capacity.
- 2. Disposer properly grounded before operating.
- 3. All connections must comply with the National Electrical Code and/or local electrical code.

OPERATIONAL

- 1. Before operating, check to assure grind chamber is free of any foreign objects.
- 2. Activate disposer - test for grinding performance and water leaks.

THANK YOU INSTALLER:

- 1. Complete Installation Check List.
- 2. Leave all literature (including Check List) for customer.
- 3. Notify dealer that electrical work and plumbing are completed.

GENERAL INSTRUCTIONS:

1. In old houses, it is generally good practice to clean out the existing drain line from sink to sewer before installing the disposer.
2. The disposer can be installed in steel, monel, stainless steel or cast iron sinks, with a sink opening of 3-1/2" to 4" without sink alteration.
3. Standard 1-1/2" O.D. or 2" O.D. drain pipe is satisfactory for drain lines. Long horizontal drain lines should be eliminated. Drum traps and grease traps should not be used.

PLUMBING INSTALLATION INSTRUCTIONS:

1. Remove existing sink drain connections and clean drain opening.
2. Remove disposer cover. Remove sink flange (1, Fig. 1), sink flange seal (2 & 3, Fig. 1) and pressure washer (4, Fig. 1) by pressing down and pushing snap ring (6, Fig. 1) clockwise. Hold snap ring and lift sink flange up and out.
3. Disassemble sink flange, sink flange seal and pressure washer.
4. Fit the sink flange seal (2, Fig. 1) to sink flange (1, Fig. 1). Insert sink flange (1, Fig. 1) into the drain opening. Be sure the sink flange is located in the center of the drain opening to assure a water-tight seal. **NOTE:** The rubber sink flange seal (2, Fig. 1) should always be used where possible. In rare instances where the contour or thickness of the sink opening does not permit use of the seal, a permanently pliable sealing compound can be used.
5. Assemble the other rubber sink flange seal (3, Fig. 1) and pressure washer (4, Fig. 1) onto the sink flange by slipping pressure washer over the top set of depressions and turning so that depressions lock pressure washer into place.
6. Lift disposer up and into sink flange (1, Fig. 1) until snap ring clicks into snap ring groove. Finger tighten the two adjusting screws (5, Fig. 1) up until they are in contact with pressure washer (4, Fig. 1). **NOTE:** The disposer is now loosely mounted.
7. Connect disposer to house drainage system and tighten spout bolts.
8. Tighten the adjusting screws (5, Fig. 1) securely to complete mounting.
9. **Install stopper and fill sink with water. Remove stopper and check for leaks. If leakage is discovered, evenly tighten adjusting screws until leakage stops.**
10. Check to assure the grinding chamber is clean of any foreign objects and the flywheel is free to rotate. Place the cover in position.
11. Installation must be in accordance with local plumbing codes.

DISHWASHER CONNECTION:

Connecting the discharge of a dishwasher to a disposer will assure all waste particles discharged by the dishwasher are properly sized and flushed to the main drain system. A dishwasher inlet consisting of a 7/8" dia. tube is provided in the side of the upper housing grinding chamber of all KitchenAid Disposers for connection of the dishwasher discharge.

1. Use a long Phillips screwdriver to force out the neoprene drain plug.
2. Remove the drain plug from the grinding chamber.
3. Connect the dishwasher drain hose to the disposer inlet using hose clamps.

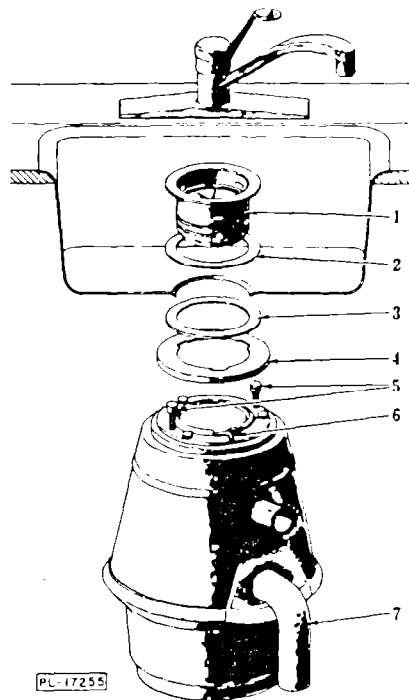
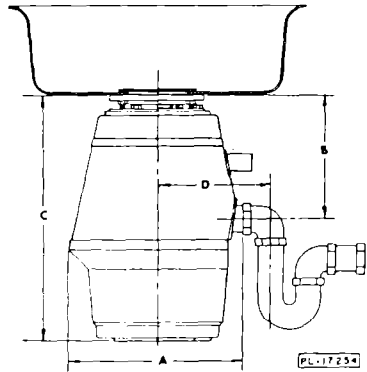

Fig. 1

TYPICAL INSTALLATIONS: Height of drain should not exceed height of disposer discharge opening.

MODEL	A	B	C	D
KWD-200	9-1/8"	8-3/8"	14-7/8"	5-1/2"
KWE-200	9-1/8"	7-1/2"	14"	5-1/2"
KWI-200	10"	7-1/2"	14-1/4"	5-1/2"
KWS-200	10"	8-3/8"	15-1/8"	5-1/2"



Typical "P" Trap Connection

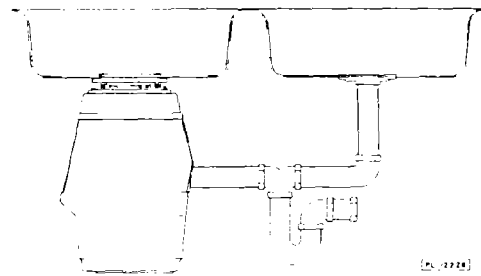

Connection With Straight-Away Drain Spout

Fig. 2

ELECTRICAL INSTALLATION INSTRUCTIONS:

WARNING: DISCONNECT ELECTRICAL POWER SUPPLY AT THE FUSE/CIRCUIT BREAKER BOX BEFORE MAKING ELECTRICAL CONNECTIONS.

Follow the National Electrical Code and/or your local electrical code in all details. In older houses with limited circuits, or if it appears the circuit is heavily loaded, run a line directly to the main fuse box.

Models KWD-200, and KWS-200 - 115 Volt, 60 Hertz.

1. Remove the electrical access cover on the bearing bracket assembly.
2. Pull out the two leads provided.
3. Install standard strain relief connector (not furnished) into the threaded opening in bearing bracket assembly.
4. Insert electrical power supply line into connector. Tighten connector.
5. Connect electrical power supply line to the two leads provided. Connect to ground (See Fig. 3 and grounding instructions below). Press wires into electrical access compartment and replace cover.

Models KWE-200, and KWI-200 - 115 Volt, 60 Hertz

Steps 1, 2, and 3 are the same as Models KWD-200, and KWS-200.

4. Install the operating control switch where it is easily accessible. Recommended: On-Off switch suitable for operation of 1/2 H.P. motor (Switch not furnished).
5. Run flexible conduit, or equivalent, from the control switch to the disposer motor leads located in the bearing bracket assembly. Insulate connections and connect unit to ground. (See Fig. 3 and grounding instructions below.)
6. Run power supply, in accordance with local codes, from control switch to electrical service panel.
7. Press wires into the electrical access compartment and replace cover.

NOTE: Models KWE-200, and KWI-200 are equipped with a manual reset (RED BUTTON) motor overload protector. Models KWD-200, and KWS-200 are equipped with an automatic reset motor overload protector. In case of overload "Trip", a minimum of three to five minutes cooling time must be allowed before resetting. If disposer has been running for more than 10-15 minutes (a "well heated" condition), reset time may be 20-25 minutes.

GROUNDING INSTRUCTIONS

This appliance must be connected to a grounded metal, permanent wiring system; or an equipment-grounding conductor must be run with the circuit conductors and connected to the equipment-grounding terminal or lead on the appliance.

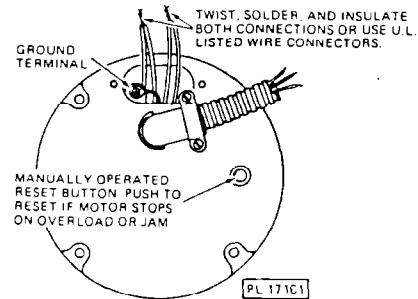

Fig. 3

KITCHENAID

FORM 14610 (5-83)

4177898

PRINTED IN U.S.A.