

This Owner's Manual is provided and hosted by [Appliance Factory Parts](http://Appliance Factory Parts).

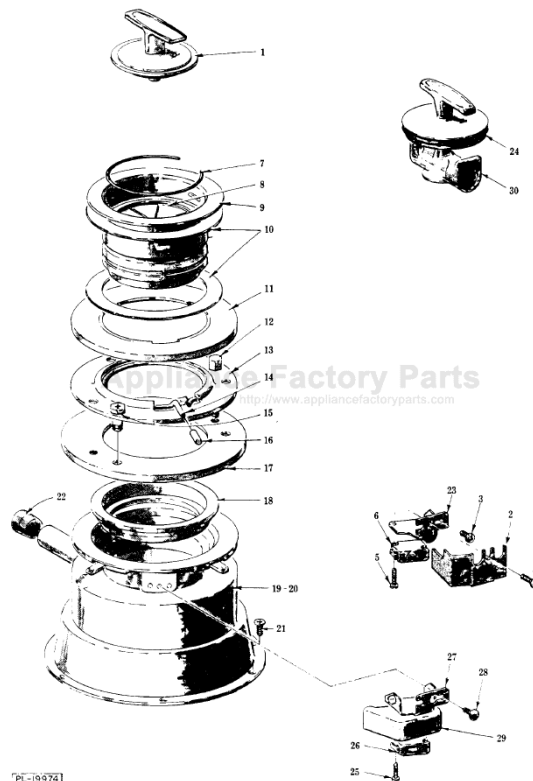

# KITCHENAID KCDC200S0 Owner's Manual

[Shop genuine replacement parts for KITCHENAID  
KCDC200S0](#)



[Find Your KITCHENAID Disposal Parts - Select From 75 Models](#)

----- Manual continues below -----

*Catalog of*

# REPLACEMENT PARTS

**KitchenAid®**

## HEAVY DUTY DISPOSERS

(CONTINUOUS FEED)

ML-42136    KWI200A  
ML-42132    KWE200A

(BATCH FEED)

ML-42131    KWS200A  
ML-42135    KWD200A

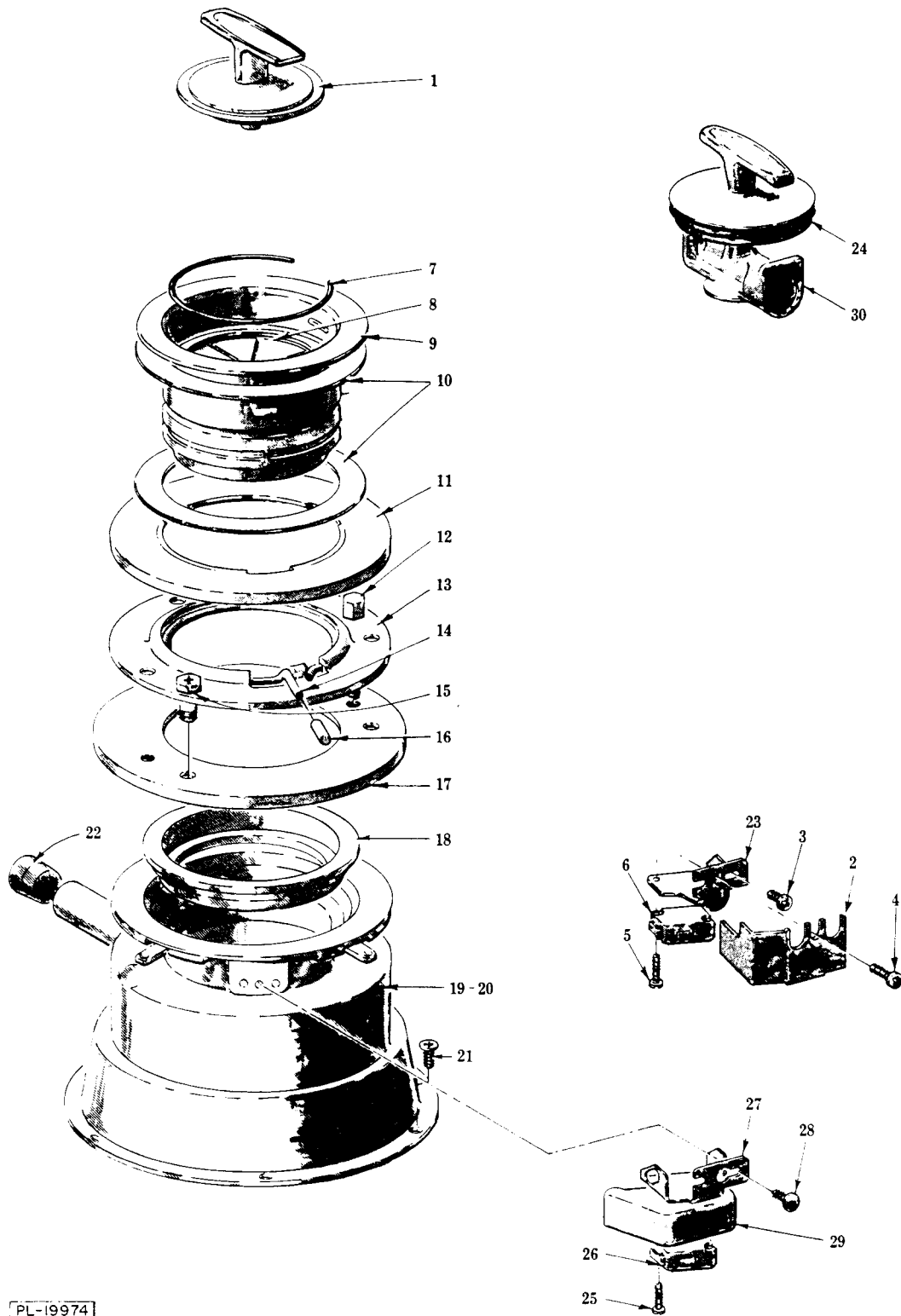

UPPER HOUSING UNIT

1	242915	Seal- Closure
2	See Note	Cover - Switch
3	SD-32-23	Self-Tapping Screw 8 x 3/8 Phil. Pan Hd., Type B
4	SD-19-31	Self-Tapping Screw 8 x 1/2 Phil. Pan Hd., Type B
5	SD-9-14	Self-Tapping Screw 4-40 x 5/8 Phil. Pan Hd., Type F
6	See Note	Switch & Magnet Assy
**7	114907	Ring- Splash Guard
**8	240871	Splash Guard Assy. (Incls. item 7)
9	114892	Flange- Sink
10	201462	Seal- Sink Flange
11	114898	Washer- Pressure
12	114897	Screw- Adjusting
13	114891	Ring- Support
14	116064	Snap Ring & Cap Assy. (Incls. item 16)
15	114909	Screw - Hold-Down
16	115803	Cap- Snap Ring
17	114899	Plate - Pressure
18	114905	Ring- Seal
*19	242295	Upper & Lower Housing Assy
*20	242296	Upper & Lower Housing Assy
21	SC-18-70	Mach. Screw 8-32 x 7/16 Phil. Pan Hd
22	242481	Plug- Drain (Dishwasher)
23	See Note	Bracket - Switch Mounting
*24	241203	Seal- Cover
*25	SD-9-14	Self-Tapping Screw 4-40 x 5/8 Phil. Pan Hd., Type F
*26	241448	Switch & Magnet Assy
*27	241336	Bracket - Switch Mounting
*28	SD-9-39	Self-Tapping Screw 8-32 x 3/8 Phil. Pan Hd., Type B
*29	241335-2	Cover - Switch
*30	241251-1	Control Cover Assy. (Incls. item 24)
	**242978	Closure Assy. (Incls. item 1)
	*242761-2	Upper Housing Assy. (Incls. items 19 & 22)
	**242761-1	Upper Housing Assy. (Incls. items 20 & 22)
	*241446	Switch, Cover & Bracket Assy. (Incls. items 10, 25, 26, 27 & 29)

Use with Batch Feed Mach.

\*\* Use with Continuous Feed Mach.

Note: Parts 2, 6 & 23 have been discontinued, order

\*241446 to convert to new style.

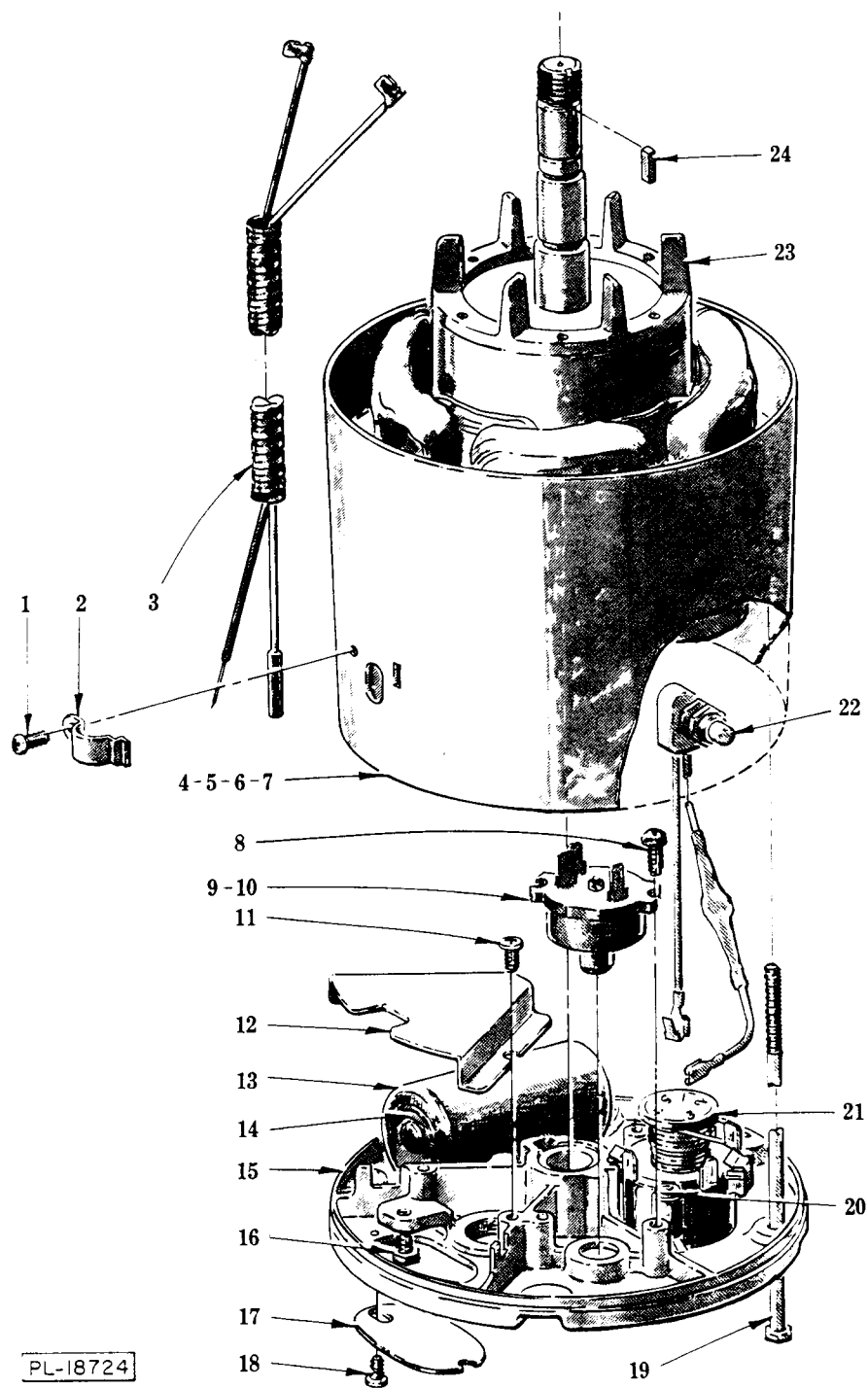

ELECTRICAL UNIT

1	SD-19-31	Self-Tapping Screw 8 x 1/2 Phil. Pan Hd., Type B
*2	114911	Clamp- Conduit
*3	115406	Conduit Assy
**4	65477-116-1	Stator Assy. (115 V., 60 Hz.) (KWE)
*5	117140-1	Stator Assy. (115 V., 60 Hz.) (KWD)
**6	116697-1	Stator Assy. (115 V., 60 Hz.) (KWI)
*7	116696-1	Stator Assy. (115 V., 60 Hz.) (KWS)
8	278497	Screw Assy. (Protector)
**9	201822-1	Protector- Overload (Manual) (115 V., 60 Hz.)
*10	201823-1	Protector- Overload (Automatic) (115 V., 60 Hz.)
11	SD-12-30	Self-Tapping Screw 6-32 x 5/16 Phil. Pan Hd., Type T
12	115314	Barrier- Elec. Enclosure
13	70487-15	Capacitor (115 V., 60 Hz.)
14	108871	Clip- Capacitor Retainer
15	109562-1	Bracket & Bearing Assy
16	202559	Screw - Mach. Grounding
17	109923	Cover - Elec. Access
18	SD-12-30	Self-Tapping Screw 6-32 x 5/16 Phil. Pan Hd., Type T
19	113690	Mach. Screw 10-32 x 5 5/8 Indented Hex Hd
20	SD-33-37	Self-Tapping Screw 6-32 x 1 Phil. Pan Hd., Type T
21	113657-5	Reversing Relay Assy. (115 V., 60 Hz.)
22	116702	Switch & Diode Assy. (115 V., 60 Hz.) (KWI-200/KWS-200)
23	22275-234	Rotor Assy. (115 V., 60 Hz.)
24	240509	Key- Sq. Mach
	ML-42140	Power Pak (115 V., 60 Hz.) (KWE)
	ML-42139	Power Pak (115 V., 60 Hz.) (KWD)
	ML-42137	Power Pak (115 V., 60 Hz.) (KWI)
	ML-42138	Power Pak (115 V., 60 Hz.) (KWS)

\*Use on Batch Feed Mach. \*\*Use on Continuous Feed Mach.

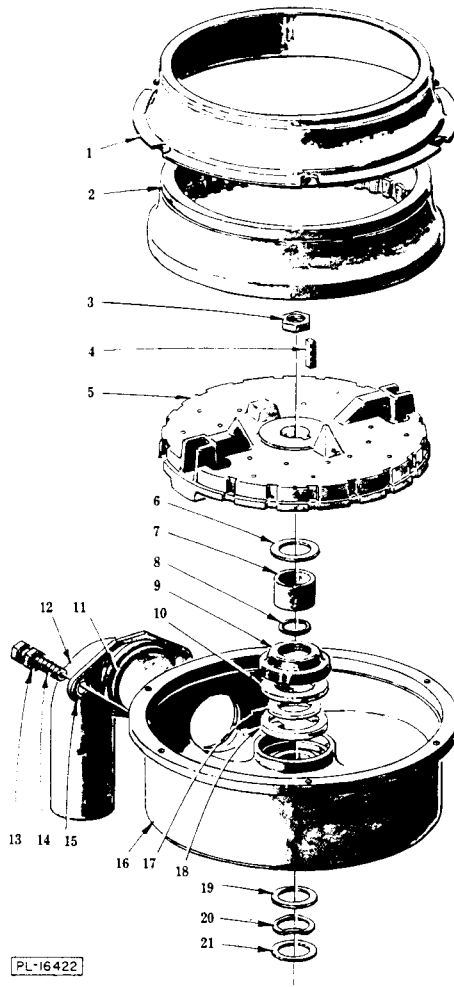

**POWER UNIT**

1	115804	Seal- Shredder Ring
2	242555	Ring- Shredder
3	NS-17-41	Jam Nut 5/8-18 Hex Fin
4	240290	Lock- Jam Nut
5	242556	Flywheel
6	202732	Washer- Wear
7	202927	Sleeve- Seal
8	201444-8	"O" Ring
9	201469	Seal- Water
10	115805	Felt (Lubricant)
11	115818	Seal - Spout
12	240119	Spout & Seal Assy. (Incls. item 11)
13	NS-13-2	Full Nut 1/4-20 Hex Fin
14	115866	Screw- Special
15	241026	Flange- Spout
16	115511-1	Lower Housing & Bearing Assy
17	202734	Washer- Upper Thrust
18	240592	Felt Wiper Kit
19	WS-11-50	Washer (Nylon)
20	115461	Washer - Wavy
21	WS-11-49	Washer
	240593-1	Seal Kit (Incls. items 6, 7, 8, 9, 10 & 17 thru 21)
	240594-1	Seal & Lower Housing Kit (Incls. items 6, 7, 8, 9, 10 & 16 thru 21)
	201252	Spout Screw Assy. (Incls. items 13 & 14)
	242028	Flywheel Assy. Kit (Incls. items 5 & 6)

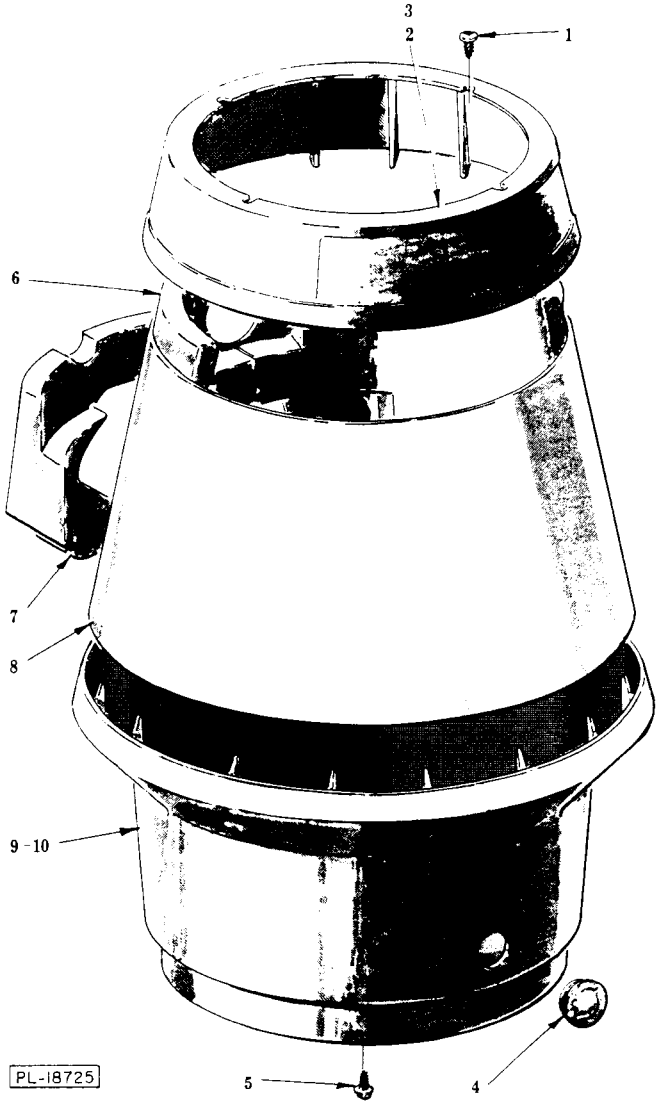

SHELL UNIT (KWI & KWS)

1 SD-15-41 Self-Tapping Screw 8-32 x 1/2 Phil. Pan Hd., Type TT  
\*\*2 242060-3 Cap- Top (KWI)  
\*3 243144 Top Cap & Label (KWS)  
4 115409 Button- Anti-Jam  
5 SD-12-32 Self-Tapping Screw 6-32 x 3/8 Indented Hex Washer Hd., Type T  
6 115425 Insulation- Upper  
7 115365 Liner- Drain  
8 242024 Trim - Band Assy  
\*9 242119-3 Lower Shell & Label Assy. (KWS)  
\*10 242119-4 Lower Shell & Label Assy. (KWI)  
\*242115-5 Cap, Shell & Trim Band Assy. (Incls. items 3, 8 & 9) (KWS)  
\*\*242115-6 Cap, Shell & Trim Band Assy. (Incls. items 2, 8 & 10) (KWI)  
\* Use on Batch Feed Mach. \*\* Use on Continuous Feed Mach.

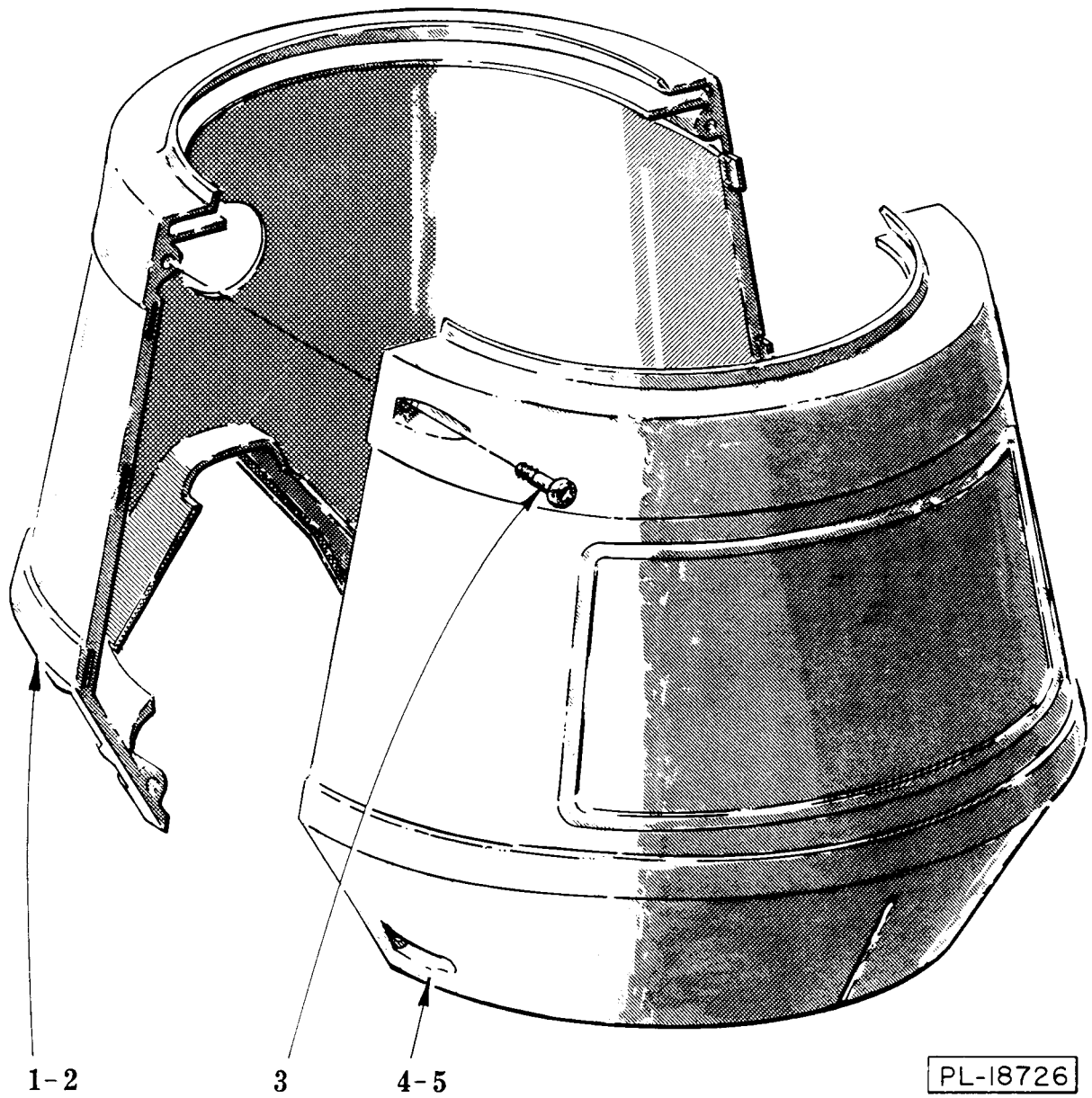

SHELL UNIT (KWD & KWE)

\*\*1 115353-3 Shell- Rear (KWE)  
\*2 115352-3 Shell- Rear (KWD)  
3 115369 Self-Tapping Screw 6-20 x 11/16 Phil. Pan Hd., Type B  
\*\*4 115669-6 Front Shell & Label (KWE)  
\*5 115669-5 Front Shell & Label (KWD)  
\*Use on Batch Feed Mach. \*\*Use on Continuous Mach.