

This Owner's Manual is provided and hosted by [Appliance Factory Parts](#).



Master Chef G20717 Owner's Manual

[Shop genuine replacement parts for Master Chef
G20717](#)



[Find Your Master Chef Grill Parts - Select From 118 Models](#)

----- Manual continues below -----



S280 Barbecue Assembly Manual

85-3002-6 (G20717) Propane

1 YEAR LIMITED WARRANTY

**READ AND SAVE MANUAL FOR FUTURE REFERENCE.
If pre-assembled, leave this manual with unit for
consumer's future reference.**

**For product inquiries, parts, warranty and
troubleshooting support, please call 1-877-707-5463.**

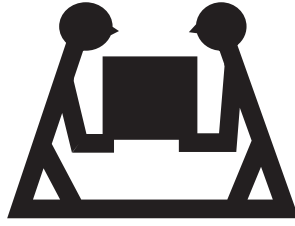

HEAVY ARTICLE NEEDS 2 TO LIFT

THIS MANUAL MUST REMAIN WITH THE PRODUCT AT ALL TIMES

To ORDER non-warranty replacement parts or accessories, or to register your warranty, please visit us on the web at

www.masterchefbbqs.com

⚠ CAUTION

Sharp edges. Wear gloves when assembling your grill.

⚠ CAUTION

Read and follow all safety statements, assembly instructions, and use and care directions before attempting to assemble and cook.

⚠ INSTALLER OR ASSEMBLER/CONSUMER

This manual should be kept with the BBQ at all times.

⚠ WARNING

Failure to follow all of the Manufacturer's instructions could result in hazardous fires, explosions, property damage, or serious personal injury or even death.

Follow all leak check procedures carefully prior to operation of barbecue, even if grill was dealer assembled. Do not try to light this barbecue without reading the Lighting Instructions section of this manual.

⚠ DANGER

1. If you smell Gas:
 - a. Shut off gas to the appliance
 - b. Extinguish any open flame
 - c. Open lid
 - d. If odor continues, keep away from the appliance and immediately call your gas supplier or your fire department
 2. Requires two people to complete the assembly process.
 3. Beware of sharp edges.
-

⚠ WARNING

1. Do not store or use gasoline or other flammable liquids or vapours in the vicinity of this or any other appliance.
 2. An LP cylinder not connected for use shall not be stored in the vicinity of this or any other appliance.
-

THIS BARBECUE IS FOR OUTDOOR USE ONLY

CONTACT CALL CENTRE IF ANY PARTS ARE MISSING

1-877-707-5463

PARTS LIST (PROPANE) FOR 85-3002-6 (G20717)

| KEY # | QUANTITY | DESCRIPTION | PART NO. |
|-------|----------|----------------------------|--------------|
| AA | 1 | Top lid assembly | G208-0001-01 |
| AB | 1 | Top lid handle | G305-0090-01 |
| AC | 2 | Upper hinge | G206-0002-A1 |
| BA | 1 | Burner box assembly | G205-0010-02 |
| BB | 2 | Lower hinge | G206-0010-A1 |
| BC | 1 | Cooking grate | G206-0006-01 |
| BD | 1 | Flame tamer | G210-0003-01 |
| BE | 1 | Burner | G207-2400-01 |
| BF1 | 1 | Collector Box | G206-0014-02 |
| BF2 | 1 | Electrode | G206-0302-02 |
| BG | 1 | Heat shield | G207-0032-01 |
| CA | 1 | Control panel | G207-0029-01 |
| CB | 3 | Control knob | G401-0023-01 |
| CC | 1 | Ignitor | G206-0301-01 |
| CD | 1 | Valve assembly | G208-3801-01 |
| CE | 1 | Regulator | G436-1005-01 |
| CF | 1 | Warming rack | G205-0040-01 |
| DA | 4 | Cart legs | G207-0023-01 |
| DB | 2 | Support brace | G207-0024-01 |
| DC | 2 | Burner box support | G206-0017-02 |
| DD | 1 | Grease cup hook | G305-0043-01 |
| DE | 1 | Grease cup | G430-0033-02 |
| DF | 1 | Gas tank support | G207-0036-01 |
| DG | 1 | Tank exclusion | G207-0026-01 |
| DH | 4 | Support bracket, cart legs | G207-0025-01 |
| DI | 2 | Wheel | G206-0025-01 |
| DJ | 2 | End cap | G207-0038-01 |
| DK | 1 | Condiment basket | G206-0047-01 |
| DL | 1 | Front panel | G207-0800-01 |
| DM | 1 | Match holder | G401-0079-01 |
| EA | 1 | Side shelf, right | G207-0034-01 |
| EB | 1 | Side burner table, left | G207-1200-01 |
| EC | 1 | Side burner drip pan | G304-0016-02 |
| ED | 1 | Side burner | G207-3000-01 |
| EE | 1 | Electrode set, side burner | G305-0084-01 |
| EF | 1 | Side burner grate | G303-0022-01 |
| EG | 1 | Side burner valve | G207-0033-01 |
| F1 | 1 | Manual | G207-M017-01 |
| F2 | 1 | Hardware pack | G207-B017-01 |
| F3 | 1 | Safe Use and Care Manual | G207-M015-02 |

ASSEMBLY INSTRUCTIONS

1

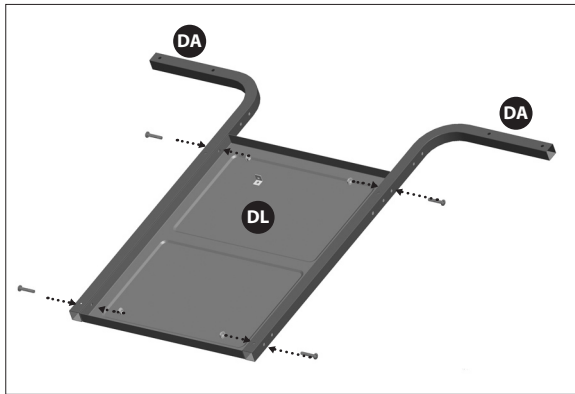

TWO PEOPLE REQUIRED FOR ALL ASSEMBLY STEPS.

a. Front Cart Assembly: assemble the front panel (DL) to two cart legs (DA) as shown.

YOU WILL NEED:

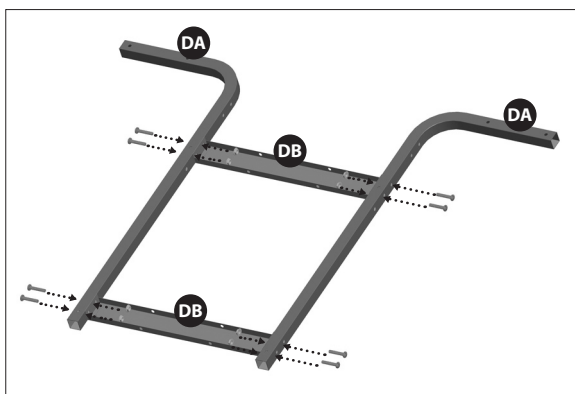
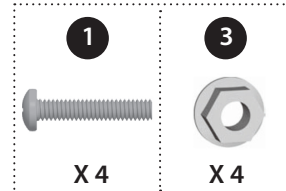

b. Back Cart Assembly: assemble two support braces (DB) to the remaining two cart legs (DA), as shown.

YOU WILL NEED:

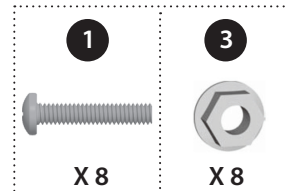

2

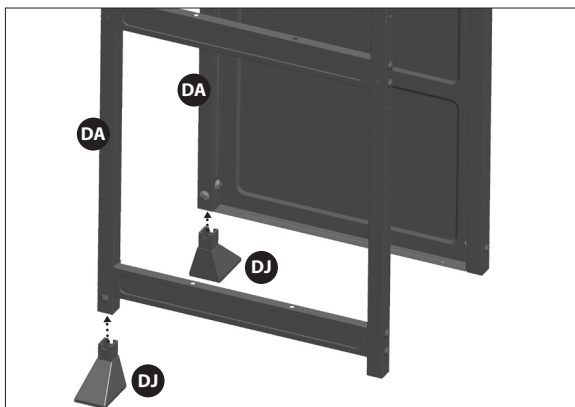

a. Assemble the end caps (DJ), to the bottom of the right side cart legs (DA).

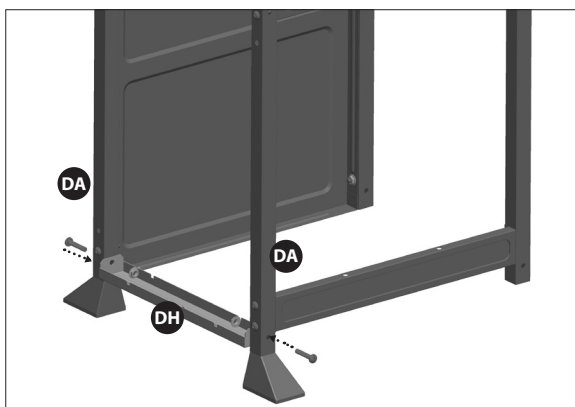

b. Assemble the right bottom brace (DH) to the front and back cart legs (DA), as shown.

Tip: Bottom brace (DH) grooves should be facing upward. Tighten all hardware securely.

YOU WILL NEED:

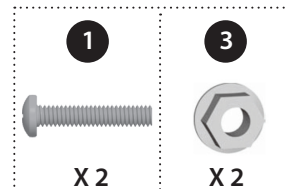

ASSEMBLY INSTRUCTIONS

4

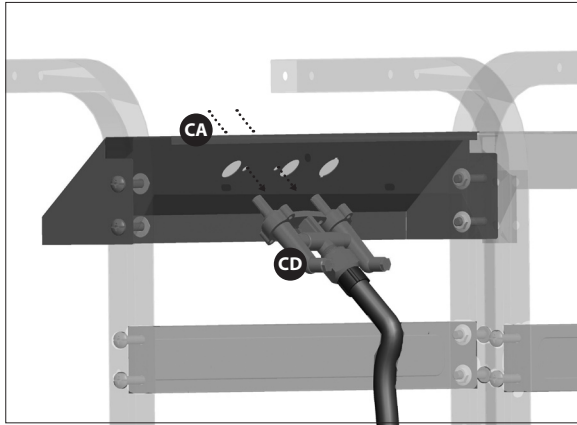

a. Position the valve assembly (CD) through the back of the control panel (CA), and assemble.

YOU WILL NEED:

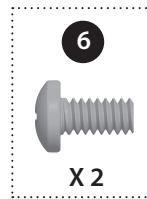

b. Position the control knobs (CB) onto valve assembly stems (CD).

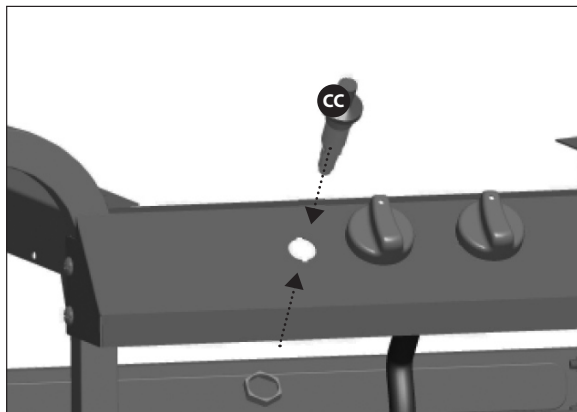
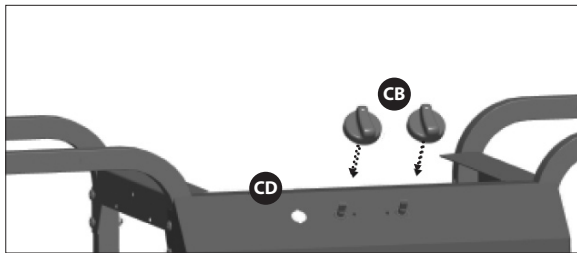

c. Assemble the igniter (CC) through the front of the control panel (CA), as shown.

ASSEMBLY INSTRUCTIONS

6

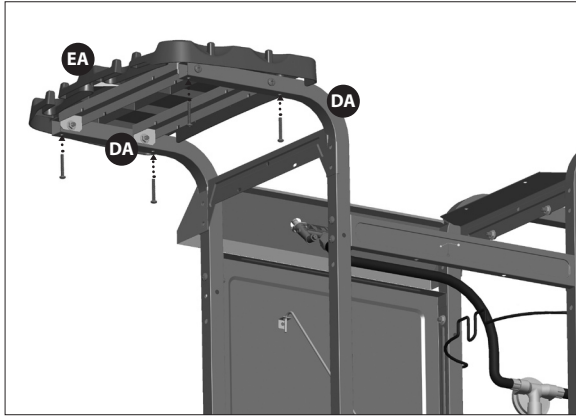

View from the back of cart assembly

SIDE SHELF ASSEMBLY

- a. Assemble the right side shelf (EA) to the right cart legs (DA), as shown.

YOU WILL NEED:

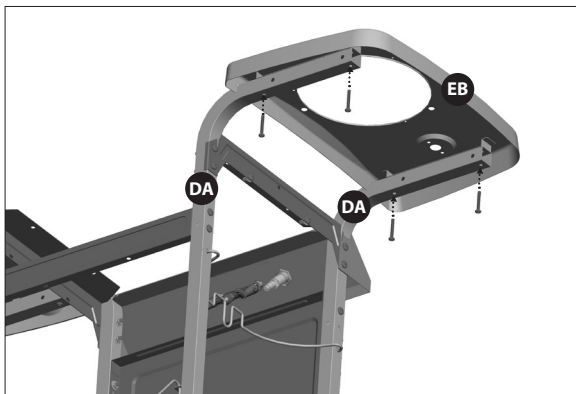
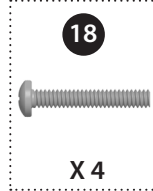

View from the back of cart assembly

- b. Assemble the left side burner table (EB) to the left cart legs (DA) by sliding the side burner table on to the cart legs as shown.

YOU WILL NEED:

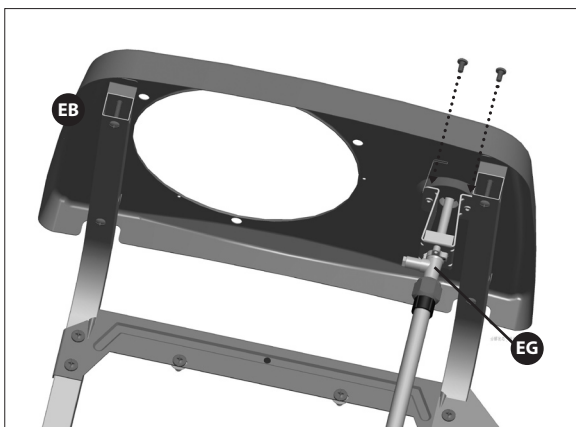
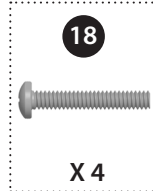

- c. Assemble the side burner valve assembly (EG) to the side burner table (EB).

YOU WILL NEED:

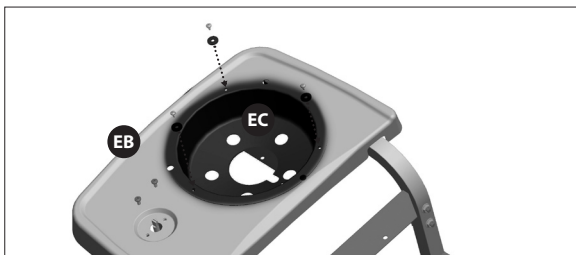
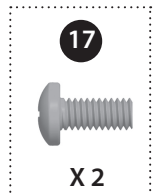

- d. Assemble the side burner drip pan (EC) to the side burner table (EB), as shown.

YOU WILL NEED:

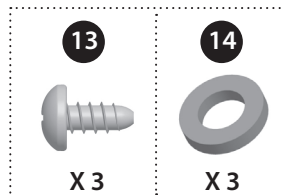

ASSEMBLY INSTRUCTIONS

7

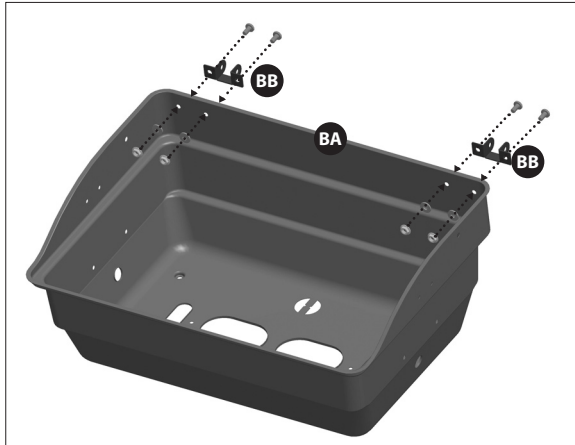

BURNER BOX ASSEMBLY

a. Assemble the lower hinge (BB) x 2 on the back of the burner box assembly (BA), as shown.

YOU WILL NEED:

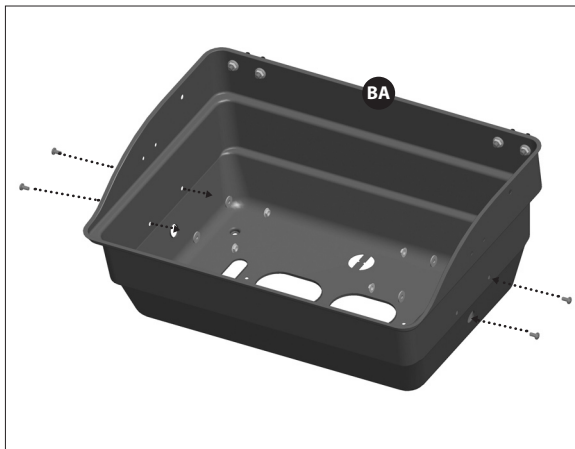
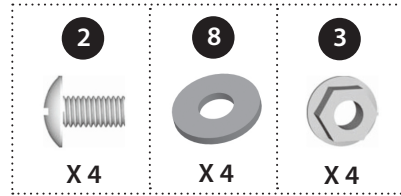

b. Assemble hardware into burner box assembly (BA), as shown. **Note: This hardware will be used in a later step to support the flame tamer (BD).**

YOU WILL NEED:

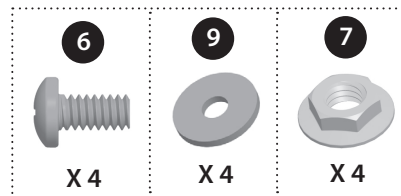

ASSEMBLY INSTRUCTIONS

10

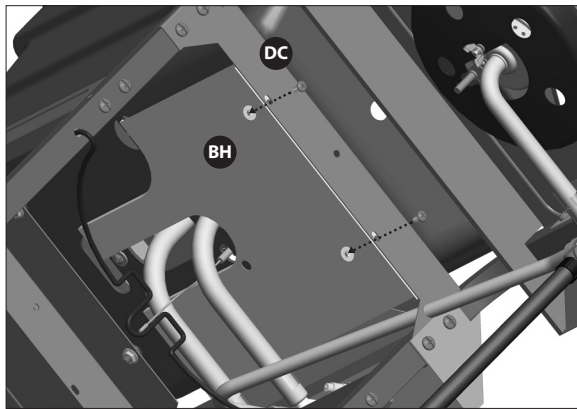
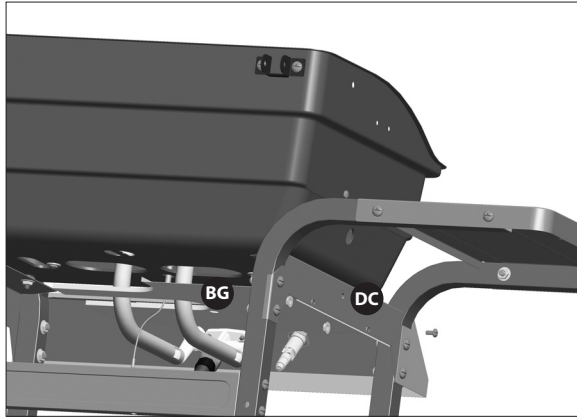

Assemble the heat shield (BG) to the inside of the left burner box support (DC), as shown.

YOU WILL NEED:

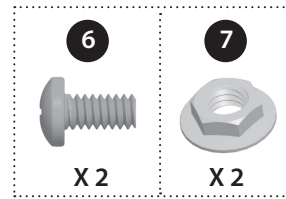

**CAUTION: SHARP EDGES,
WEAR SAFETY GLOVES DURING
ASSEMBLY**

11

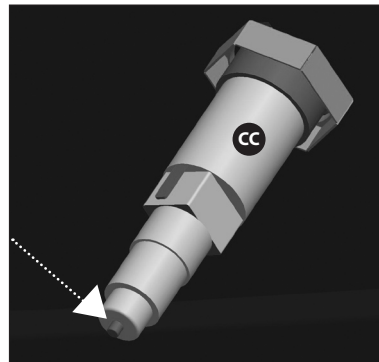
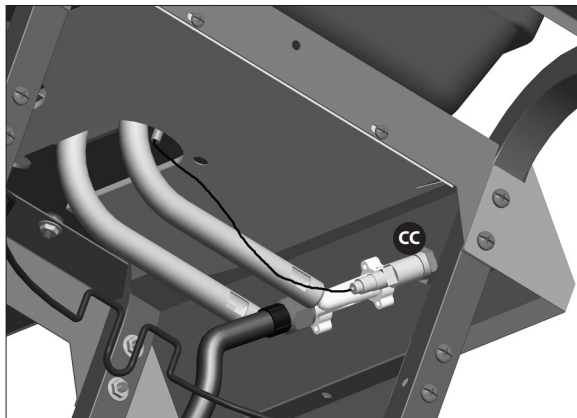

Attach the electrode wire (BF2) to the igniter (CC).

ASSEMBLY INSTRUCTIONS

15

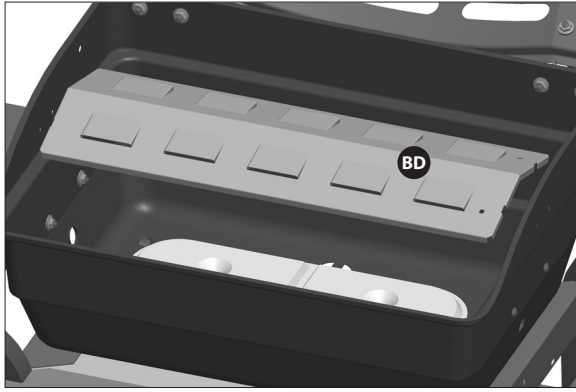

Position the flame tamer (BD) into the burner box assembly (BA). **Note: The flame tamer (BD) should be placed on to the hardware assembled in Step 7b.**

16



Position the cooking grate (BC) into the burner box assembly (BA).

ASSEMBLY INSTRUCTIONS

19



Hook the grease cup hook (DD) to the bottom of the burner box assembly (BA), as shown. Place the grease cup (DE) into the grease cup hook (DD).

