

This Owner's Manual is provided and hosted by [Appliance Factory Parts](#).



Kenmore 71606 Owner's Manual

[Shop genuine replacement parts for Kenmore 71606](#)



[Find Your Kenmore Refrigerator Parts - Select From 665 Models](#)

----- Manual continues below -----

Use & Care Guide
Manual de Uso y Cuidado
Guide d'Utilisation et d'Entretien
English / Español / Français

Models/Modelos/Modèles: 795.7160*

Kenmore®

Bottom Freezer Refrigerator

Congelador Inferior Refrigerador

Congélateur Inférieur Réfrigérateur

* = color number, número de color, le numéro de la couleur

P/N MFL37933569
Sears Brands Management Corporation
Hoffman Estates, IL 60179 U.S.A.
www.kenmore.com
www.sears.com

Sears Canada Inc.
Toronto, Ontario, Canada M5B 2B8
www.sears.ca



TABLE OF CONTENTS

English Version	2	Removing Humidity Controlled Crisper	22
Spanish Version	38	Glide‘N’Serve	22
French Version	74	Modular Door Bin	23
Warranty	3	Dairy Bin	23
Protection Agreements	4	► Freezer Section	
Safety Instructions	5–7	Ice Bin	23
Grounding Requirements	7	Tilt-Out Door Basket	24
Parts And Features	8	Durabase	24
Refrigerator Installation	9–17	Durabase Divider	24
Unpacking Your Refrigerator	9	PullOut Drawer	24
Installation	10	Care And Cleaning	25–26
Removing And Replacing Your Refrigerator Handles And Doors	11–16	General Cleaning Tips	25
Leveling And Door Alignment	17	Outside	25
Base Cover	17	Inside Walls	25
Using Your Refrigerator	18–24	Door Liner And Gaskets	25
Setting The Controls	18	Plastic Parts	25
Adjusting Control Settings	19	Condenser Coils	25
Food Storage Guide	20	Light Bulb Replacement	25–26
Storing Frozen Food	20-21	Power Interruptions	26
► Refrigerator Section		When You Go On Vacation	26
Refrigerator Shelves	21	When You Move	26
Humidity Controlled Crisper	22	About The Automatic Icemaker	27
		Connecting The Water Line	28–30
		Troubleshooting Guide	31–35



BOTTOM FREEZER REFRIGERATOR WARRANTY

Kenmore Appliance Warranty

One Year Limited Warranty

When installed, operated and maintained according to all instructions supplied with the product, if this appliance fails due to a defect in material or workmanship within one year from the date of purchase, call 1-800-4-MY-HOME® to arrange for free repair.

If this appliance is used for other than private family purposes, this warranty applies for only 90 days from the date of purchase.

This warranty covers only defects in material and workmanship. Sears will NOT pay for:

1. Expendable items that can wear out from normal use, including but not limited to filters, belts, light bulbs, and bags.
2. A service technician to instruct the user in correct product installation, operation or maintenance.
3. A service technician to clean or maintain this product.
4. Damage to or failure of this product if it is not installed, operated or maintained according to all instructions supplied with the product.
5. Damage to or failure of this product resulting from accident, abuse, misuse or use for other than its intended purpose.
6. Damage to or failure of this product caused by the use of detergents, cleaners, chemicals or utensils other than those recommended in all instructions supplied with the product.
7. Damage to or failure of parts or systems resulting from unauthorized modification made to this product.

Disclaimer of implied warranties; limitation of remedies

Customer's sole and exclusive remedy under this limited warranty shall be product repair as provided herein,

Implied warranties, including warranties of merchantability or fitness for a particular purpose, are limited to one year or the shortest period allowed by law. Sears shall not be liable for incidental or consequential damages. Some states and provinces do not allow the exclusion or limitation of incidental or consequential damages, or limitations on the duration of implied warranties of merchantability or fitness, so these exclusions or limitations may not apply to you.

This warranty applies only while this appliance is used in the United States and Canada.

This warranty gives you specific legal rights, and you may also have other rights which vary from state to state.

Sears Brands Management Corporation, Hoffman Estates, IL 60179
Sears Canada, Inc., Toronto, Ontario, Canada M5B 2B8

PROTECTION AGREEMENTS

Master Protection Agreements

Congratulations on making a smart purchase. Your new Kenmore® product is designed and manufactured for years of dependable operation. But like all products, it may require preventive maintenance or repair from time to time. That's when having a Master Protection Agreement can save you money and aggravation.

The Master Protection Agreement also helps extend the life of your new product. Here's what the Agreement* includes:

- ☑ **Parts and labor** needed to help keep products operating properly **under normal use**, not just defects. Our coverage goes **well beyond the product warranty**. No deductibles, no functional failure excluded from coverage— **real protection**.
- ☑ **Expert service** by a force of more than **10,000 authorized Sears service technicians**, which means someone you can trust will be working on your product.
- ☑ **Unlimited service calls and nationwide service**, as often as you want us, whenever you want us.
- ☑ **"No-lemon"** guarantee – replacement of your covered product if four or more product failures occur within twelve months.
- ☑ **Product replacement** if your covered product can't be fixed.
- ☑ **Annual Preventive Maintenance Check** at your request – no extra charge.
- ☑ **Fast help by phone** – we call it **Rapid Resolution** – phone support from a Sears representative on all products. Think of us as a "talking owner's manual."

- ☑ **Power surge protection** against electrical damage due to power fluctuations.
- ☑ **\$250 Food Loss Protection** annually for any food spoilage that is the result of mechanical failure of any covered refrigerator or freezer.
- ☑ **Rental reimbursement** if repair of your covered product takes longer than promised.
- ☑ **10% discount** off the regular price of any non-covered repair service and related installed parts.

Once you purchase the Agreement, a simple phone call is all that it takes for you to schedule service. You can call anytime day or night, or schedule a service appointment online.

The Master Protection Agreement is a risk free purchase. If you cancel for any reason during the product warranty period, we will provide a full refund. Or, a prorated refund anytime after the product warranty period expires.

Purchase your Master Protection Agreement today!

Some limitations and exclusions apply.

For prices and additional information in the U.S.A. call 1-800-827-6655

*** Coverage in Canada varies on some items. For full details call Sears Canada at 1-800-361-6665.**

Sears Installation Service

For Sears professional installation of home appliances, garage door openers, water heaters, and other major home items, in the U.S.A. or **Canada call 1-800-4-MY-HOME®**.

PRODUCT RECORD

In the space below, record the date of purchase, model and serial number of your product. You will find the model and serial number printed on an identification label located on the right-hand side of the refrigerator compartment. Have these items of information available whenever you contact Sears concerning your product.

Model No. _____

Date of Purchase _____

Serial No. _____

Save these instructions and attach your sales receipt for future reference.

IMPORTANT SAFETY INSTRUCTIONS

BASIC SAFETY PRECAUTIONS

This guide contains many important safety messages. Always **read and obey** all safety messages.



This is the safety alert symbol. It alerts you to safety messages that inform you of hazards that can kill or hurt you or others, or cause damage to the product.

All safety messages will be preceded by the safety alert symbol and the hazard signal word DANGER, WARNING, or CAUTION. These words mean:



DANGER

You **will** be killed or seriously injured if you do not follow instructions.



WARNING

You **can** be killed or seriously injured if you do not follow instructions.



CAUTION

Indicates an imminently hazardous situation which, if not avoided, **may** result in minor or moderate injury, or product damage only.

All safety messages will identify the hazard, tell you how to reduce the chance of injury, and tell you what can happen if the instructions are not followed.

WARNING

To reduce the risk of fire, electric shock, or personal injury when using your product, basic safety precautions should be followed, including the following.

Read all instructions before using this appliance.

- NEVER unplug your refrigerator by pulling on the power cord. Always grip the plug firmly and pull it straight out from the outlet.
- Repair or replace immediately all electric service cords that have become frayed or otherwise damaged. Do not use a cord that shows cracks or abrasion damage along its length or at either the plug or connector end.
- Do not modify or extend the power cord length. It could cause electric shock or fire.
- When moving your refrigerator away from the wall, be careful not to roll over or damage the power cord.

- DO NOT store or use gasoline or other flammable vapors and liquids in the vicinity of this or any other appliance.
- DO NOT allow children to climb, stand, or hang on the refrigerator doors or shelves in the refrigerator. They could damage the refrigerator and seriously injure themselves.
- Keep fingers out of pinch point areas; clearances between the doors and cabinet are necessarily small. Be careful closing doors when children are in the area.
- Unplug your refrigerator before cleaning or making any repairs.

NOTE: We strongly recommend that any servicing be performed by a qualified individual.

SAVE THESE INSTRUCTIONS

⚠️ WARNING

- Before replacing a burned-out light bulb, **unplug** the refrigerator or turn off power at the circuit breaker or fuse box in order to avoid contact with a live wire filament. (A burned-out light bulb may break when being replaced.)
NOTE: Some models have LED interior lighting and service should be performed by a qualified technician.
- When you are finished, reconnect the refrigerator to the electrical source and reset the controls. (Thermostat, Refrigerator Control, and or Freezer Control, depending on the model) to the desired setting.
- This refrigerator must be properly installed in accordance with the **Attention Installer Instructions** that were taped to the front of the refrigerator.
- After your refrigerator is in operation, do not touch the cold surfaces in the freezer compartment when hands are damp or wet. Skin may adhere to the extremely cold surfaces.
- In refrigerators with automatic icemakers, avoid contact with the moving parts of the ejector mechanism, or with the heating element that releases the cubes. **DO NOT** place fingers or hands on the automatic icemaking mechanism while the refrigerator is plugged in.
- **DO NOT** refreeze frozen foods which have thawed completely. The United States Department of Agriculture in Home and Garden Bulletin No. 69 says:
 - ... You may safely refreeze frozen foods that have thawed if they still contain ice crystals or if they are still cold—below 4°C.
 - ... Thawed ground meats, poultry or fish that have any off-odor or off-color should not be refrozen and should not be eaten. Thawed ice cream should be discarded. If the odor or color of any food is poor or questionable, dispose of it. The food may be dangerous to eat.Even partial thawing and refreezing reduces the eating quality of foods, particularly fruits, vegetables and prepared foods. The eating quality of red meats is affected less than that of many other foods. Use refrozen foods as soon as possible to save as much of their quality as you can.

SAVE THESE INSTRUCTIONS

IMPORTANT SAFETY INSTRUCTIONS

- This appliance is not intended for use by persons (including children) with reduced physical, sensory or mental capabilities, or lack of experience and knowledge, unless they have been given supervision or instruction concerning use of the appliance by a person responsible for their safety.
- Children should be supervised to ensure that they do not play with the appliance.

⚠️ DANGER: RISK OF CHILD ENTRAPMENT

Junked or abandoned refrigerators are dangerous...even if they will sit for just a few days. If you are getting rid of your old refrigerator, please follow the instructions at right to help prevent accidents (Child entrapment and suffocation).

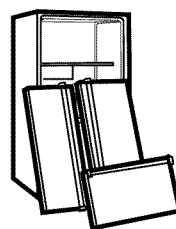

BEFORE YOU THROW AWAY YOUR OLD REFRIGERATOR OR FREEZER

- Take off the doors.
- Leave the shelves in place so that children may not easily climb inside.

CFC DISPOSAL

Your old refrigerator may have a cooling system that used CFCs (chlorofluorocarbons). CFCs are believed to harm stratospheric ozone.

If you are throwing away your old refrigerator, make sure the CFC refrigerant is removed for proper disposal by a qualified servicer. If you intentionally release this CFC refrigerant, you can be subject to fines and imprisonment under provisions of environmental legislation.

GROUNDING REQUIREMENTS

IMPORTANT: Please read carefully.
TO CONNECT ELECTRICITY

⚠ WARNING

Electrical Shock Hazard

FOR PERSONAL SAFETY, this appliance must be properly grounded. Have the wall outlet and the circuit checked by a qualified electrician to make sure the outlet is properly grounded.

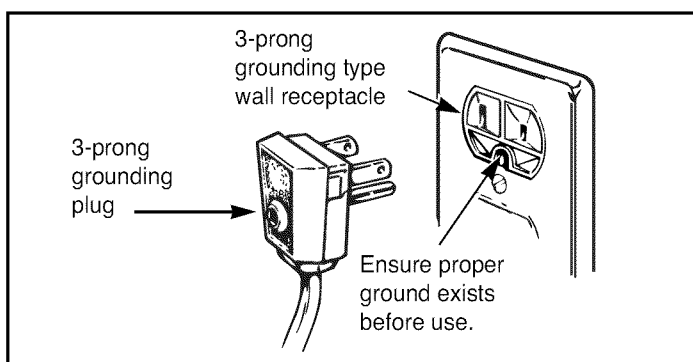

RECOMMENDED GROUNDING METHOD

The refrigerator should always be plugged into its own individual properly grounded electrical outlet rated for 115 Volts, 60 Hz, AC only, and fused at 15 or 20 amperes. This provides the best performance and also prevents overloading house wiring circuits which could cause a fire hazard from overheated wires. It is recommended that a separate circuit serving only this appliance be provided.

Use a receptacle which cannot be turned off with a switch or pull chain. Do not use an extension cord.

Where a standard two-prong wall outlet is encountered, it is your personal responsibility and obligation to have it replaced with a properly grounded three-prong wall outlet.

Do not, under any circumstances, cut or remove the third (ground) prong from the power cord.

Do not use an adapter plug.

NOTE: Before performing any type of installation, cleaning, or removing a light bulb, disconnect the refrigerator from the electrical source.

NOTE: Some models have LED interior lighting and service should be performed by a qualified technician.

When you are finished, reconnect the refrigerator to the electrical source and reset the control (Thermostat, Refrigerator Control, or Freezer Control, depending on the model) to the desired setting.

USE OF EXTENSION CORDS

Because of potential safety hazards under certain conditions, we strongly recommend against the use of an extension cord. However, if you still elect to use an extension cord, it is absolutely necessary that it be a UL-listed (USA), 3-wire grounding type appliance extension cord having a grounding type plug and outlet, and that the electrical rating of the cord be 15 amperes (minimum) and 120 volts.

Use of an extension cord will increase the clearance needed for the back of the refrigerator.

PARTS AND FEATURES

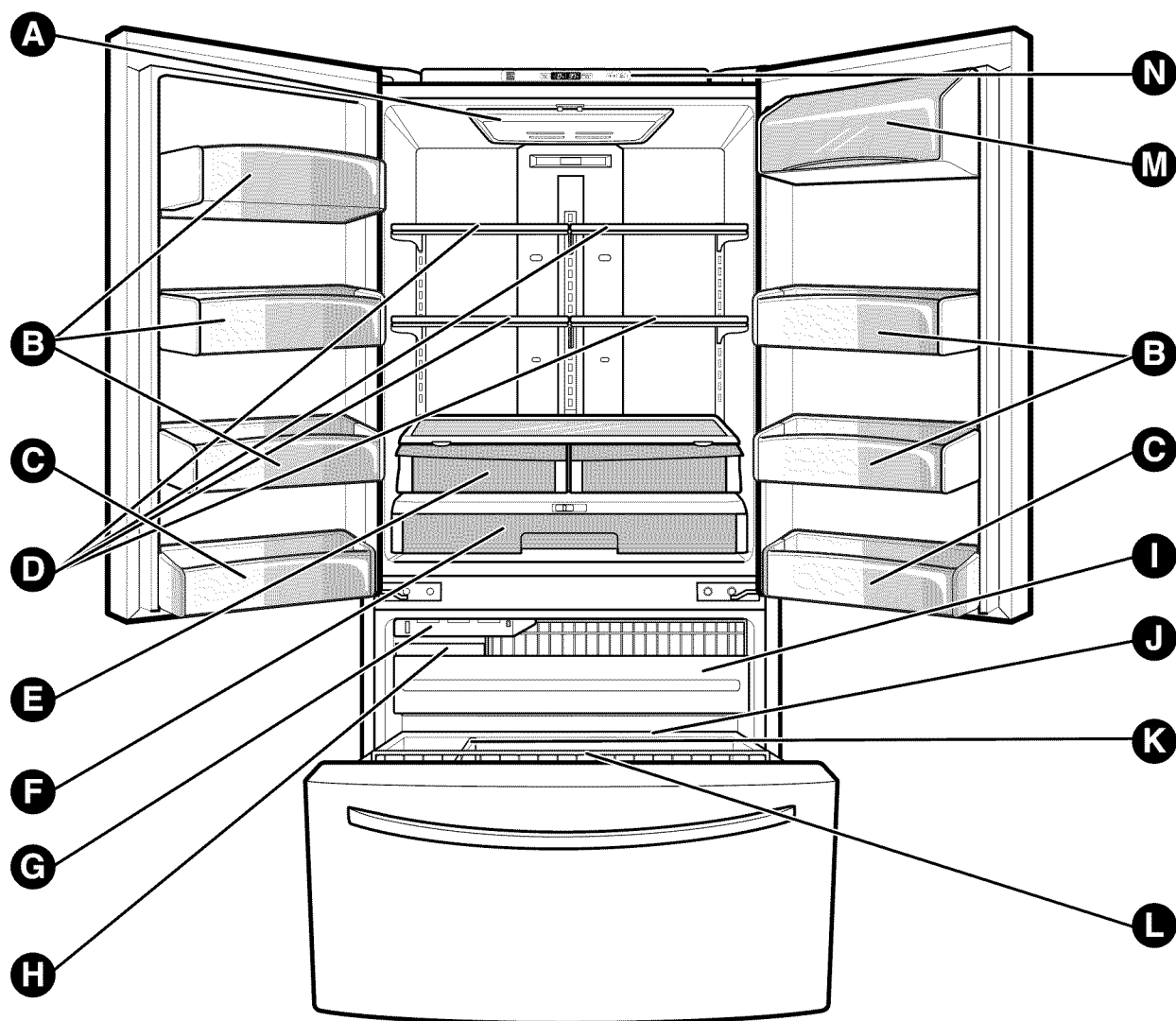

Use this page to become more familiar with the parts and features. Page references are included for your convenience.

NOTE: This guide covers several different models. The refrigerator you have purchased may have some or all of the items listed below. The locations of the features shown below may not match your model.

- | | |
|---|--|
| A Refrigerator Light (p. 25) | I Pull out Drawer (p. 24) |
| B Modular Door Bins (Cantilever door bins) (p. 23) | J Durabase (p. 24) |
| C Fixed door bins | K Divider (p. 24) |
| D Refrigerator Shelves (p. 21) | L Tilt-Out Door Basket (p. 24) |
| E Humidity Controlled Crisper (p. 22) | M Dairy Bin (p. 23) |
| F Glide'N'Serve (p. 22) | N Digital Control Panel (p. 18) |
| G Automatic Icemaker (p. 27) | |
| H Ice Bin (p. 23) | |

REFRIGERATOR INSTALLATION

WARNING

Excessive Weight Hazard

Use two or more people to move and install refrigerator. Failure to do so can result in back or other injury.

UNPACKING YOUR REFRIGERATOR

Remove tape and any temporary labels from your refrigerator before using. Do not remove any warning-type labels, the model and serial number label, or the Tech Sheet that is located under the front of the refrigerator, behind the base cover.

To remove any remaining tape or glue, rub the area briskly with your thumb. Tape or glue residue can also be easily removed by rubbing a small amount of liquid dish soap over the adhesive with your fingers. Wipe with warm water and dry.

Do not use sharp instruments, rubbing alcohol, flammable fluids, or abrasive cleaners to remove tape or glue. These products can damage the surface of your refrigerator. For more information, see the **Important Safety Instructions** section.

Refrigerator shelves are installed in the shipping position.

Please reinstall shelves according to your individual storage needs.

WARNING

When Moving Your Refrigerator:

Your refrigerator is heavy. When moving the refrigerator for cleaning or service, be sure to protect the floor. Always pull the refrigerator straight out when moving it. Do not wiggle or walk the refrigerator when trying to move it, as floor damage could occur.

WARNING

Explosion Hazard

Keep flammable materials and vapors, such as gasoline, away from refrigerator.



Failure to do so can result in death, explosion, or fire.

- To reduce the risk of electric shock, do not install the refrigerator in a wet or damp area.
- Select a place where a water supply can be easily connected for the automatic icemaker.

▲ CAUTION: Avoid placing the unit near heat sources, direct sunlight or moisture.

REFRIGERATOR INSTALLATION

INSTALLATION

- To minimize noise and vibration, the refrigerator **MUST** be installed on a solidly constructed floor.
 - Carpeting and soft tile surfaces are not recommended.
 - Never install the refrigerator on a platform or weakly supported structure.
1. To avoid vibration, the unit must be leveled. If required, adjust the leveling legs to compensate for unevenness of the floor. The front should be slightly higher than the rear to aid in door closing. Leveling legs can be turned easily by tipping the cabinet slightly. Turn the leveling legs clockwise () to raise the unit, counterclockwise () to lower it.
(See Leveling and Alignment: on page 17.)
 2. Install this appliance in an area where the temperature is between 55°F (13°C) and 110°F (43°C.) If the temperature around the appliance is too low or high, cooling ability may be adversely affected.
 3. Too small a distance from adjacent items may result in lowered freezing capability and increased electricity consumption charges. Allow at least 24 inches (61 cm) in front of the refrigerator to open the doors.

PRIOR TO USE

1. Clean your refrigerator thoroughly and wipe off all dust accumulated during shipping.
2. Install accessories such as ice cube bin, drawers, shelves, etc., in their proper places. They are packed together to prevent possible damage during shipment.
3. Let your refrigerator run for at least 2 or 3 hours before putting food in it. Check the flow of cold air in the freezer compartment to ensure proper cooling. Your refrigerator is now ready for use.

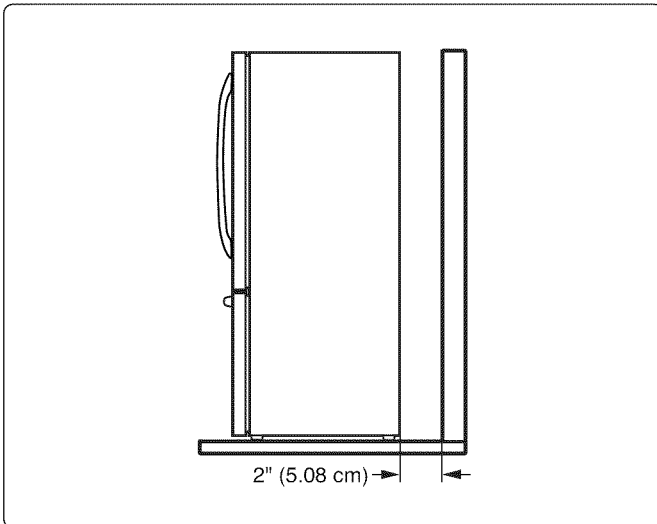

REFRIGERATOR INSTALLATION

NOTE: Removing the doors is always recommended when it is necessary to move the refrigerator through a narrow opening. If it is necessary to remove the handles, follow the directions below.

HOW TO REMOVE DOOR HANDLES

NOTE: Handle appearance may vary from illustrations on this page.

1. Removing Refrigerator Handle

- Loosen the set screws with a 3/32" (2.5mm) Allen wrench and remove the handle.

NOTE: If the handle mounting fasteners need to be tightened or removed, use a 1/4" (6.4mm) Allen wrench.

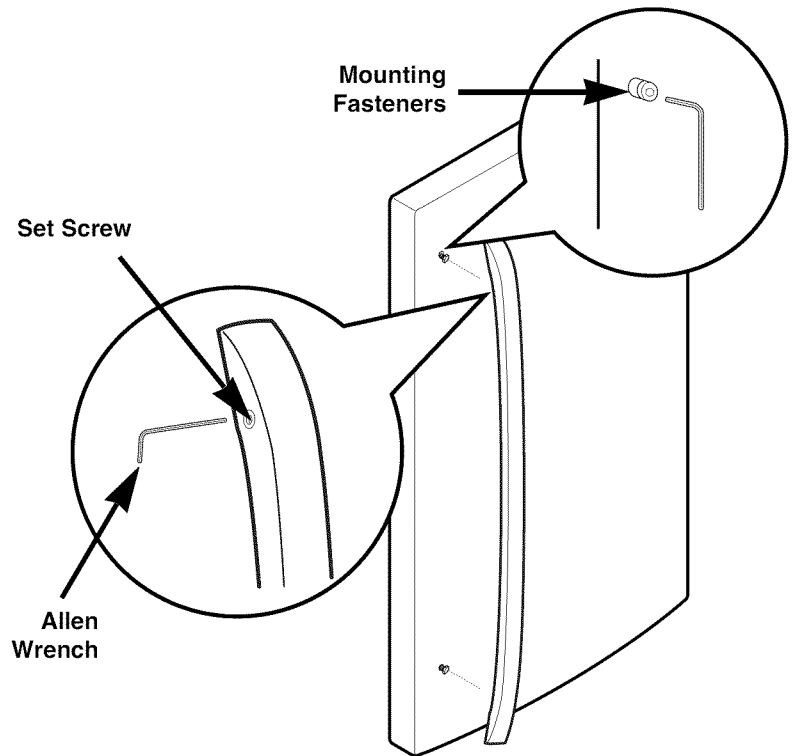

2. Removing Freezer Drawer Handle

- Loosen the set screws located on the lower side of the handle with a 1/8" (3.1mm) Allen wrench and remove the handle.

NOTE: If the handle mounting fasteners need to be tightened or removed, use a 1/4" (6.4mm) Allen wrench.

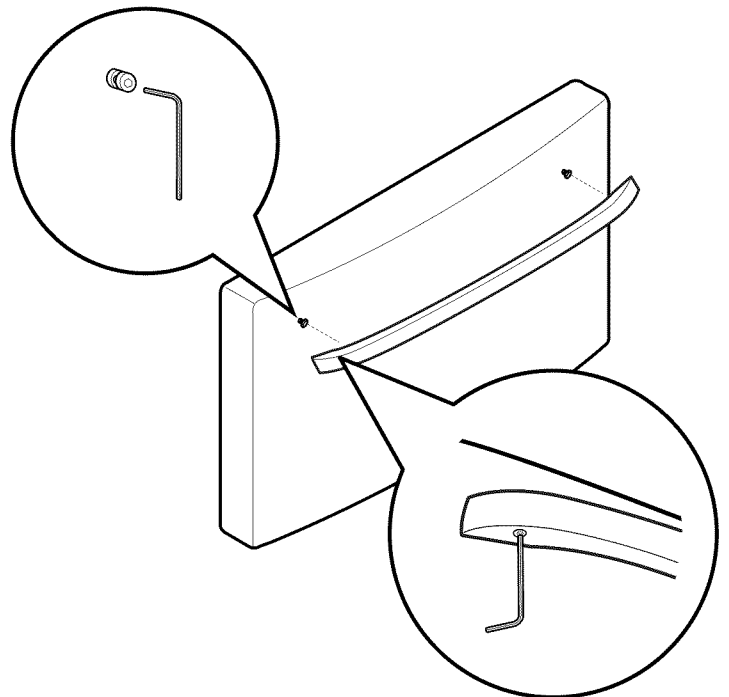

REFRIGERATOR INSTALLATION

HOW TO REPLACE DOOR HANDLES

NOTE: Handle appearance may vary from illustrations on this page.

1. Replacing Refrigerator Door Handle

- Place the handle on the door, fitting it over the mounting fasteners and tighten the set screws with a 3/32" (2.5mm) Allen wrench.

NOTE: If the handle mounting fasteners need to be tightened or removed use a 1/4" (6.4mm) Allen wrench.

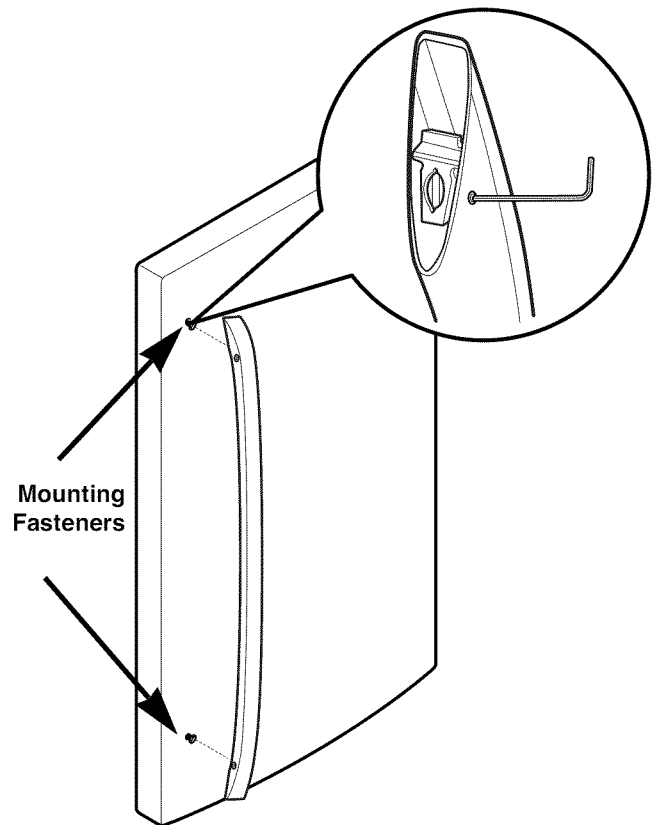

2. Replacing Freezer Drawer Handle

- Place the handle on the door, fitting it over the mounting fasteners and tighten the set screws on the bottom of the handle with a 1/8" (3.1mm) Allen wrench.

NOTE: If the handle mounting fasteners need to be tightened or removed use a 1/4" (6.4mm) Allen wrench.

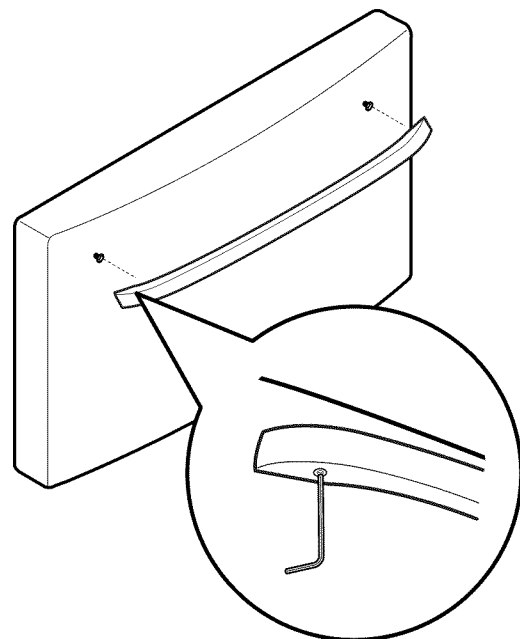

REFRIGERATOR INSTALLATION

HOW TO REMOVE REFRIGERATOR DOOR

1. Removing Refrigerator Door

NOTE: Handle appearance may vary.

IMPORTANT: Unplug the refrigerator. Remove food and any bins from doors.

► Left Door

- Loosen the cover screw (1).
- Disconnect wire harness (2).
- Remove the ground screw (3).
- Rotate the lever hinge (4) counter clockwise and lift off the top hinge (5).
- Remove the door by lifting it off the middle hinge pins, located at the bottom of the door.
- Place the door on soft, smooth surface with the inside up to prevent damage.

► Right Door

- To remove the right door, follow the same directions described for removing the left door, except rotate the lever hinge (4) clockwise to remove the top hinge (5).

▲ CAUTION: When removing top hinges, be careful that the doors do not fall forward.

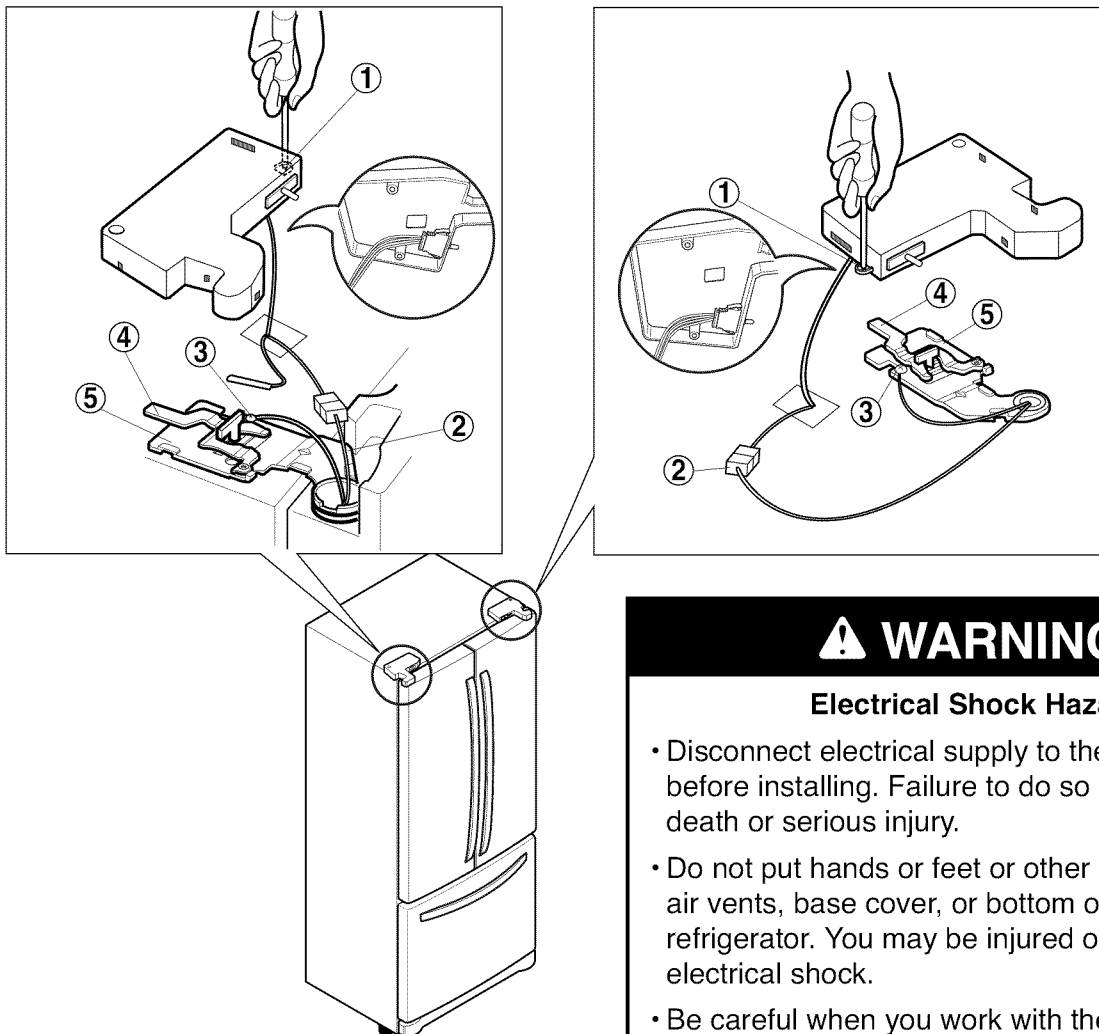

REFRIGERATOR INSTALLATION

2. Replacing Refrigerator Door

► Right Door

- Lower the door onto the middle hinge pin (6).
- Make sure the door is aligned with the cabinet.
- Replace the top hinge (5) by rotating the lever hinge (4) counter clockwise to secure it.
- Make sure the gasket on the door is flush against the cabinet and is not folded.
- Support the door on the handle side while securing. Make sure the door is straight and the gap between the doors is even across the front.
- Install the ground screw (3) and connect the wire harness (2).
- Tighten the cover screw (1).

► Left Door

- To replace the left door, follow the same directions described above.
- When replacing the top hinge (5), rotate the lever hinge (4) clockwise.

NOTE: Make sure that the washers [part (7)] is in place on the middle hinges before installing the doors.

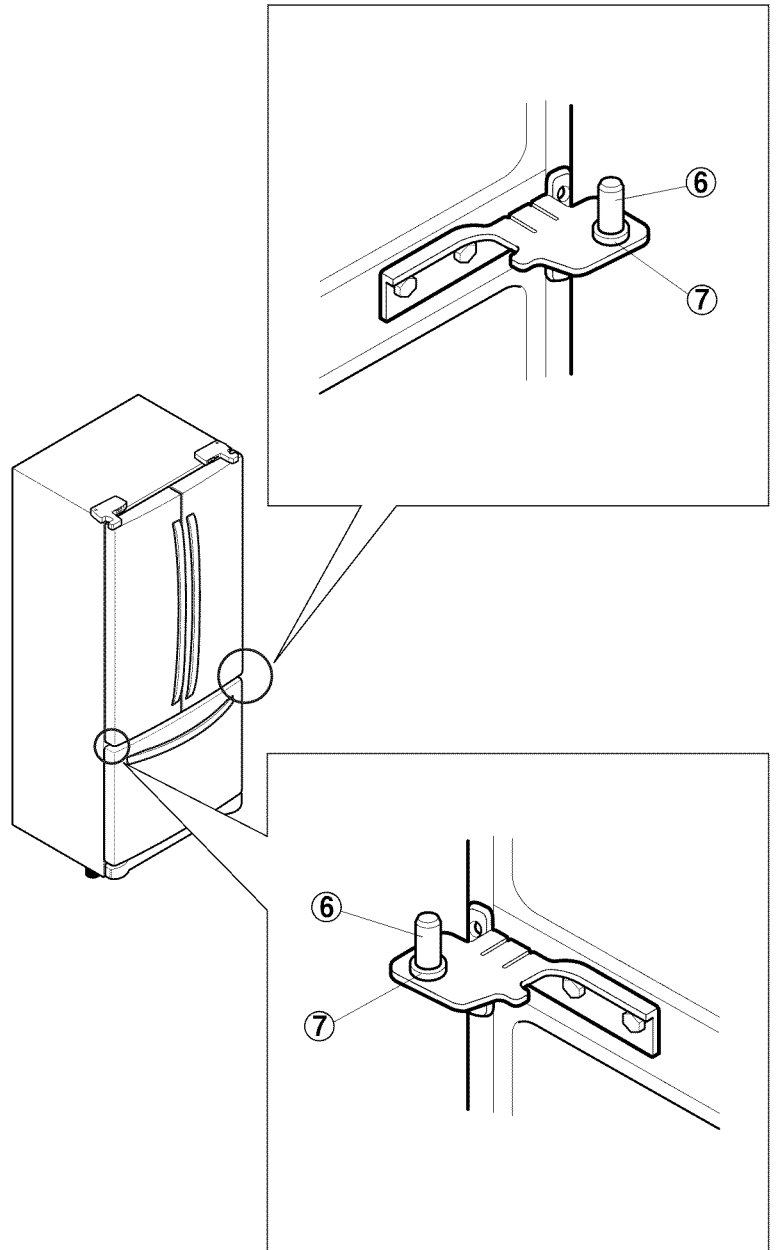

REFRIGERATOR INSTALLATION

HOW TO REMOVE AND INSTALL THE FREEZER DRAWER

IMPORTANT: To avoid possible injury or product or property damage, you will need two people to perform the following instructions.

1. Removing Freezer Drawer

- Pull the drawer open to full extension. Remove the lower basket ① by lifting basket from rail system.

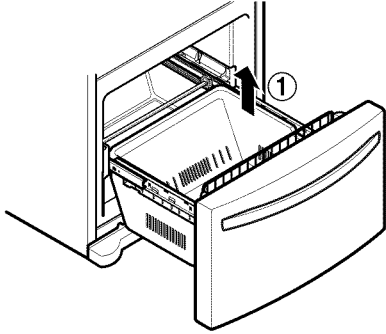

- Press in the tabs on the rail covers and lift them up to separate them from the rail assembly.

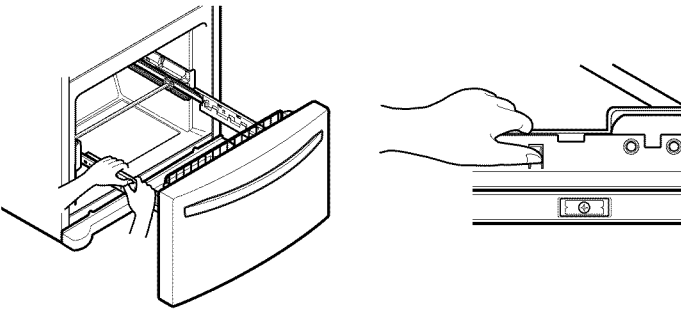

- Remove the rail screw ② on both the left and right rails.

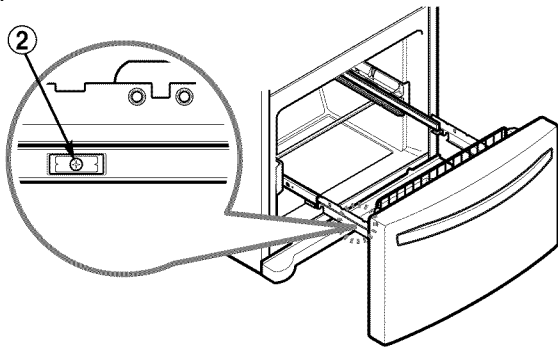

- With both hands, grasp the sides of the door and pull it up to separate it from the rails.

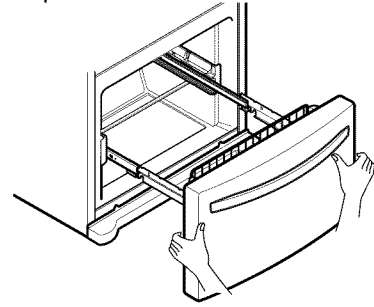

- ▲ **CAUTION:** When you remove the drawer, do not lift it by the handle. If it may come off and it could cause personal injury.

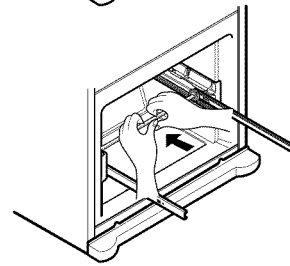
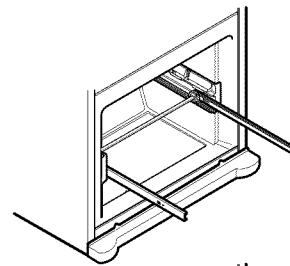

- With both hands hold the center bar and push it in to slide both rails in at the same time.

REFRIGERATOR INSTALLATION

HOW TO REMOVE AND INSTALL THE FREEZER DRAWER (cont.)

2. Installing Freezer Drawer

- Fully extend the rails by grasping the center bar with both hands and pulling straight out.

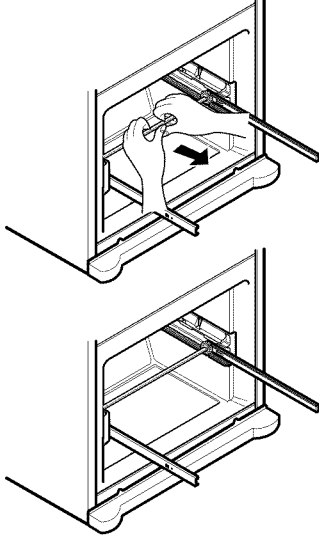

- Hook the door support ① into the rail tabs ② on both sides.

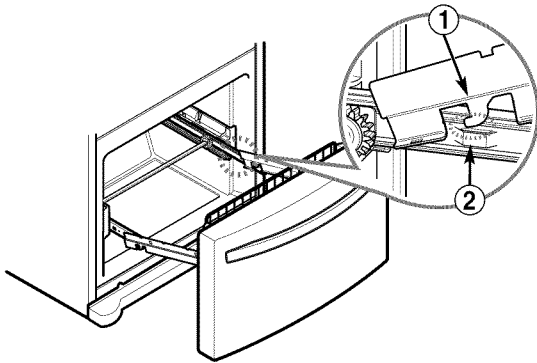

- Lower door into final position and tighten the screws ③.

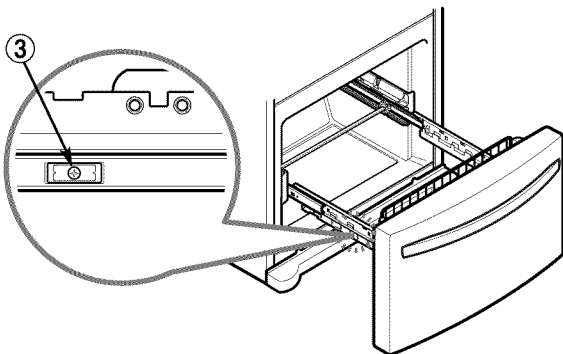

- Make sure you have the correct rail cover for each side.

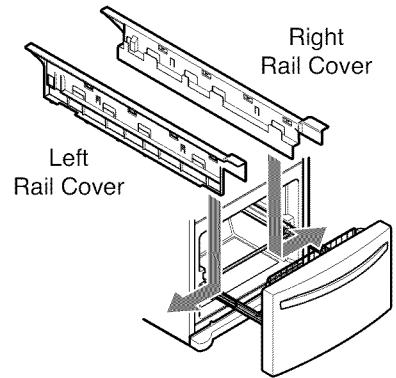

- Align the tabs on the covers to the assembly holes on each rail, and snap the rail covers in place to secure.

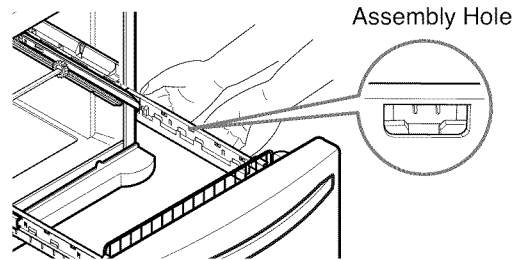
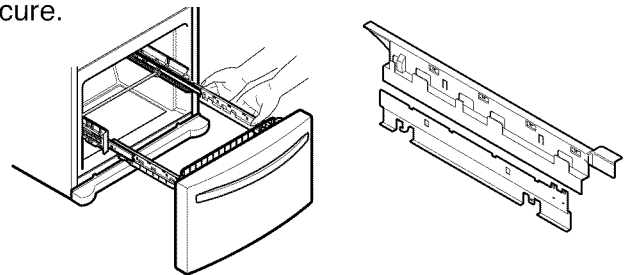

- With the drawer pulled out to full extension, insert the lower basket ④ in the rail assembly.

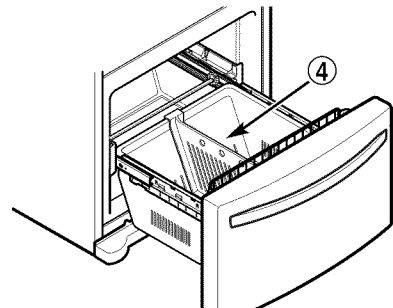

▲ **WARNING:** If the Durabase divider is removed, there is enough open space for children or pets to crawl inside.

▲ **WARNING:** To prevent accidental child and pet entrapment or suffocation risk, DO NOT allow them to touch or go near the freezer drawer.

▲ **WARNING:** DO NOT step or sit down on freezer drawer.

REFRIGERATOR INSTALLATION

LEVELING AND DOOR ALIGNMENT

Leveling

After installing, secure the stability of the product with the leveling legs.

Your refrigerator has two front leveling legs—one on the right and one on the left. Adjust legs to alter tilt from front-to-back or side-to-side. If your refrigerator seems unsteady or you want the doors to close easier, adjust the refrigerator's tilt using the instructions below:

1. Plug the refrigerator's power cord into a 3-prong grounded outlet. Move the refrigerator into its final position. Remove the base cover.

To remove the base cover

- 1) Open the Freezer Drawer. (Drawer not shown for clarity.)
- 2) Once the drawer is open and there is sufficient clearance, remove screws on the top of the cover.

To replace base cover:

- Place cover into position and insert and tighten the screws.

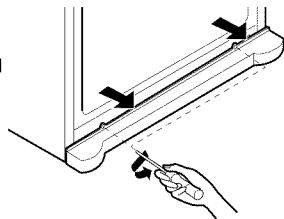

2. Turn the leveling leg clockwise to raise that side of the refrigerator or counterclockwise to lower it. It may take several turns of the leveling leg to adjust the tilt of the refrigerator.

NOTE: Having someone push backward against the top of the refrigerator takes some weight off the leveling legs. This makes it easier to adjust the legs.

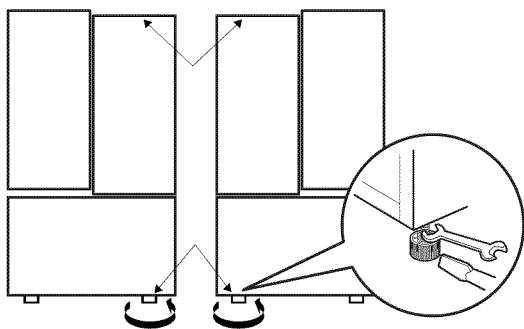

Level the refrigerator by using an 11/16 inch (18mm) wrench or a flat blade screwdriver. Turn the leveling legs counterclockwise to raise or clockwise to lower the height of the front of the refrigerator.

NOTE: The front of the refrigerator should be slightly higher than the back.

3. Open both doors again and check to make sure that they close easily. If not, tilt the refrigerator slightly more to the rear by turning both leveling legs clockwise. It may take several more turns, and you should turn both leveling legs the same amount.
4. Re-adjust if necessary.
5. Replace the base cover.

NOTE: Your new refrigerator is uniquely designed with two fresh food doors. Either door can be opened or closed independently of one another. You may have to exert slight pressure on doors to get them to close completely.

Door Alignment

If the space between your doors is uneven, follow the instructions below to align the doors:

1. With one hand, lift up the door you want to raise at the middle hinge.
2. With the other hand, use pliers to insert the snap ring as shown below.
3. Insert additional snap rings until the doors are aligned. (Three snap rings are provided with the refrigerator in the Use & Care Guide packet.)

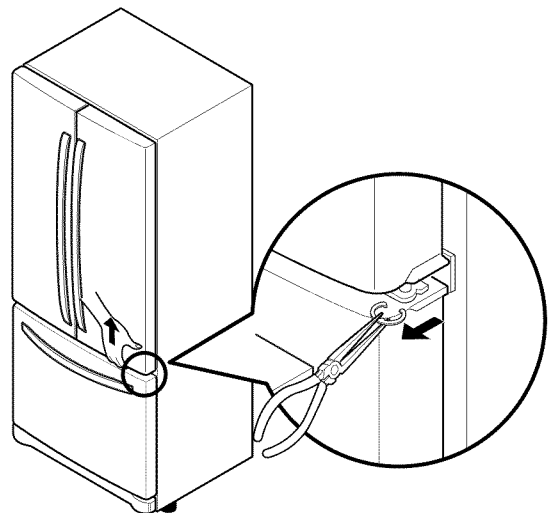

USING YOUR REFRIGERATOR

SETTING THE CONTROLS







Temperature

- Your refrigerator has a control pad above the refrigerator compartment that lets you regulate the temperature in the freezer and refrigerator compartments.
- Initially set the refrigerator control at 37°F (3°C) and the freezer control at 0°F (-18°C). Leave it at these settings for 24 hours (one day) to stabilize. Adjust the compartment temperature as desired.
- **Refrigerator Temp Control: 33°F to 46°F (0°C to 8°C)** The lower the number setting, the colder the refrigerator compartment will become.
- **Freezer Temp Control: -6°F to 8°F (-21°C to -13°C)** The lower the number setting, the colder the freezer compartment will become.

Ultra Ice

- When you press the Ultra Ice button, the graphic [Ultra Ice] will light up in the display and it continues for 24 hours. It will automatically shut off after 24 hours have passed. You can stop this function manually by pressing the button one more time.
- This function increases both icemaking and freezing capabilities.

Door Alarm

- When power is connected to the refrigerator, the door alarm is initially set to  ON and door alarm display will show the  (ON).
- When either refrigerator or the freezer door is left open for more than 60 seconds, the alarm will sound to let you know the door is open.
- When you close the door, the door alarm will stop.
- If you want to disable the door alarm function, press the  button and the door alarm display will switch to  (OFF).

⚠ CAUTION

Demo Mode (Store showroom floor Demonstration Mode)

The Demo Mode disables all cooling in the refrigerator and freezer sections to conserve energy while on display in a retail store.

1. To Activate:

With the refrigerator door opened, press and hold the Refrigerator Temp and Ultra Ice buttons at the same time for 5 seconds. The control panel will beep to confirm that the Demo Mode is activated.

2. To Deactivate:

With the refrigerator door opened, press and hold the Refrigerator Temp and Ultra Ice buttons at the same time for 5 seconds. The control panel will beep to confirm the Demo Mode is deactivated.

Airflow

In order to ensure proper temperatures, air must flow between the refrigerator and freezer sections. The arrows in the figure indicates air vent locations and the direction of airflow.

Do not block any of the cool air vents with food packages. If the vents are blocked, airflow will be interrupted. This may result in temperature and moisture problems.

If you add a large amount of food, the refrigerator will take longer to cool it.

At initial start-up allow your refrigerator to run for 2 or 3 hours before placing food in it.

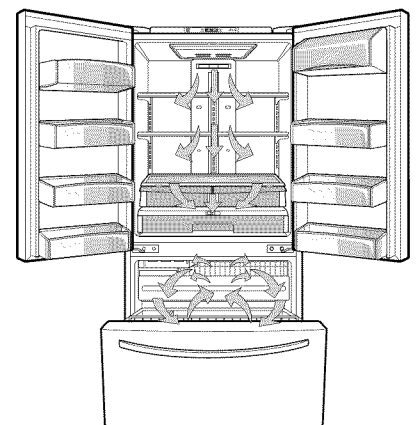

USING YOUR REFRIGERATOR

ADJUSTING CONTROL SETTINGS

It is best to wait for 24 hours for the refrigerator to cool down completely before making any adjustments to the temperature settings. The initial settings mentioned in SETTING THE CONTROLS section should be correct for normal household refrigerator use. The controls are set correctly when milk or juice is as cold as you like and when ice cream is firm.

The refrigerator control functions as the thermostat for the entire appliance (refrigerator and freezer sections). The colder the setting, the longer the compressor will run to keep the temperature colder. The freezer control adjusts the cold air flow from the freezer to the refrigerator. Setting the freezer control to a lower temperature keeps more cold air in the freezer compartment to make it colder.

If you need to adjust temperatures in the refrigerator or freezer, start by adjusting the refrigerator and allow 24 hours for the temperatures to stabilize. If it is still too warm or too cold, adjust the freezer control.

Always remember to wait at least 24 hours between adjustments.

CONDITION/ REASON:	RECOMMENDED ADJUSTMENT:
<ul style="list-style-type: none"> ■ REFRIGERATOR section too warm – Door opened often – Large amount of food added – Room temperature very warm 	Adjust the REFRIGERATOR temperature. Note: When changing temperature settings, make adjustments one increment at a time and wait 24 hours between adjustments.
<ul style="list-style-type: none"> ■ FREEZER section too warm/ice not made fast enough – Door opened often – Large amount of food added – Very cold (below 55 °F) room temperature (Compressor does not cycle often enough) – Heavy ice usage – Air vents blocked by items 	Adjust the FREEZER temperature. Note: when changing temperature settings, make adjustments one increment at a time and wait 24 hours between adjustments. Move items out of airstream
<ul style="list-style-type: none"> ■ REFRIGERATOR section too cold – Controls not set correctly for your conditions 	Set REFRIGERATOR control one degree higher C or two degrees higher F, wait 24 hours, then re-check
<ul style="list-style-type: none"> ■ FREEZER section too cold – Controls not set correctly for your conditions 	Set FREEZER control one degree higher C or two degrees higher F, wait 24 hours, then re-check

USING YOUR REFRIGERATOR

FOOD STORAGE GUIDE

Wrap or store food in the refrigerator in airtight and moisture-proof material unless otherwise noted. This prevents food odor and taste transfer throughout the refrigerator. For dated products, check date code to ensure freshness.

Items	How to
Butter or margarine	▶ Keep opened butter in a covered dish or closed compartment. When storing an extra supply, wrap in freezer packaging and freeze.
Cheese	▶ Store in the original wrapping until you are ready to use it. Once opened, rewrap tightly in plastic wrap or aluminum foil.
Milk	▶ Wipe milk cartons. For best storage, place milk on interior shelf, not on door shelf.
Eggs	▶ Store in original carton on interior shelf, not on door shelf.
Fruit	▶ Wash, let dry, and store in refrigerator in plastic bags or in the crisper. Do not wash or hull berries until you are ready to use them. Sort and keep berries in their original container in a crisper, or store in a closed and sealed paper bag on a refrigerator shelf.
Leafy vegetables	▶ Remove store wrapping and trim or tear off bruised and discolored areas. Wash in cold water and drain. Place in plastic bag or plastic container and store in crisper.
Vegetables with skins (carrots, peppers)	▶ Place in plastic bags or plastic container and store in crisper.
Fish	▶ Use fresh fish and shellfish the same day purchased.
Leftovers	▶ Cover leftovers with plastic wrap or aluminum foil. Plastic containers with tight lids can also be used.

STORING FROZEN FOOD

NOTE: For further information about preparing food for freezing or food storage times, check a freezer guide or a reliable cookbook.

Packaging

Successful freezing depends on correct packaging. When you close and seal the package, it must not allow air or moisture in or out. If it does, you could have food odor and taste transfer throughout the refrigerator and also dry out frozen food.

Packaging recommendations:

- Rigid plastic containers with tight-fitting lids
- Straight-sided canning/freezing jars
- Heavy-duty aluminum foil
- Plastic-coated paper
- Non-permeable plastic wraps
- Specified freezer-grade self-sealing plastic bags

Follow package or container instructions for proper freezing methods.

Do not use

- Bread wrappers
- Containers without tight lids
- Wax paper or wax-coated freezer wrap
- Thin, semi-permeable wrap

⚠ CAUTION: Do not keep beverage cans or plastic food containers in the freezer compartment. They may break or burst if they freeze.

USING YOUR REFRIGERATOR

Freezing

Your freezer will not quick-freeze any large quantity of food. Do not put more unfrozen food into the freezer than will freeze within 24 hours (no more than 2 to 3 lbs of food per cubic foot of freezer space). Leave enough space in the freezer for air to circulate around packages. Be careful to leave enough room at the front so the door can close tightly.

Storage times will vary according to the quality and type of food, the type of packaging or wrap used (airtight and moisture-proof) and the storage temperature. Ice crystals inside a sealed package are normal. This simply means that moisture in the food and air inside the package have condensed, creating ice crystals.

NOTE: Allow hot foods to cool at room temperature for 30 minutes, then package and freeze. Cooling hot foods before freezing saves energy.

REFRIGERATOR SECTION

REFRIGERATOR SHELVES

The shelves in your refrigerator are adjustable to meet your individual storage needs. Your model may have glass or wire shelves.

Storing similar food items together in your refrigerator and adjusting the shelves to fit different heights of items will make finding the exact item you want easier; it will also reduce the amount of time the refrigerator door is open, saving energy.

IMPORTANT: Do not clean glass shelves with warm water while they are cold. Shelves may break if exposed to sudden temperature changes or impact, such as bumping. For your protection, glass shelves are made with tempered glass, which will shatter into small pebble-sized pieces.

NOTE: Glass shelves are heavy. Use special care when removing them to avoid dropping them.

Adjusting Shelves

Remove shelves from the shipping position and replace shelves in the position you want.

- **To remove a shelf**—Tilt up the front of the shelf in the direction of ① and lift it in the direction of ②. Pull the shelf out.

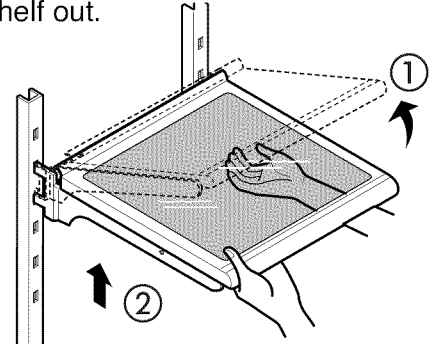

- **To reinstall a shelf**—Tilt the front of the shelf up and guide the shelf hooks into the slots at a desired height. Then lower the front of the shelf so that the hooks drop into the slots.

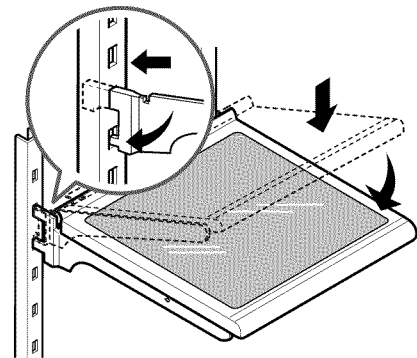

- ▲ **CAUTION:** Make sure that shelves are level from one side to the other. Failure to do so may result in the shelf falling or spilling food.

Sliding Out Shelves

You can slide glass shelves in and out of your refrigerator as follows.

- **To slide the shelf out**, carefully pull front of shelf toward you.
- **To slide shelf in**, push shelf in until it stops.

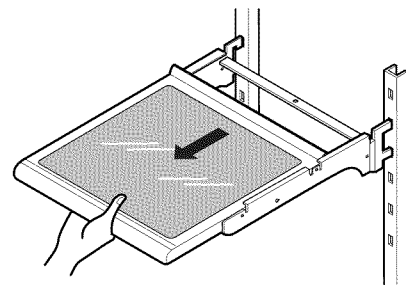

USING YOUR REFRIGERATOR

HUMIDITY CONTROLLED CRISPER

The crispers provide fresher-tasting fruit and vegetables by letting you easily control humidity inside the drawer.

You can control the amount of humidity in the moisture-sealed crispers. Adjust the control to any setting between **VEGETABLE** and **FRUIT**.

- **VEGETABLE** keeps moist air in the crisper for best storage of fresh, leafy vegetables.
- **FRUIT** lets moist air out of the crisper for best storage of fruits.

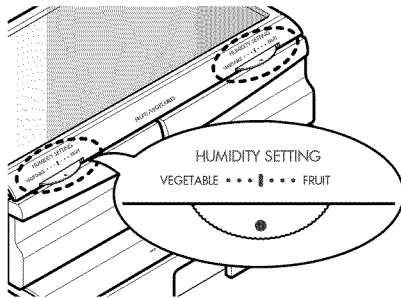

REMOVING HUMIDITY CONTROLLED CRISPER

1. To remove, pull the drawer out to full extension.
2. Lift the front of the crisper up, then pull it straight out.
3. To install, slightly tilt up the front and insert the drawer into the frame and push it back into place.

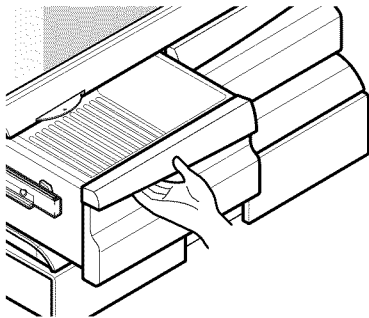

To remove the glass

1. Lift up the glass under the crisper cover.
2. Pull the glass up and out.

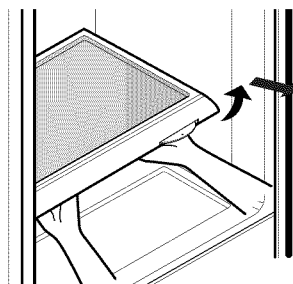

GLIDE'N'SERVE

The **Glide'N'Serve** provides storage space with a variable temperature control that keeps the compartment colder than the refrigerator temperature.

This drawer can be used for large party trays, deli items, or beverages.

Note: It is not recommended that this drawer be used for fruits and vegetables.

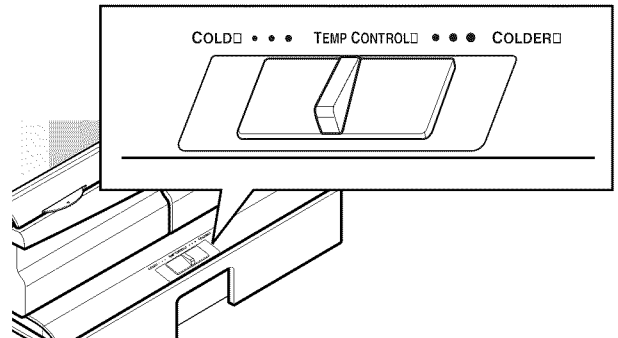

Glide 'N' Serve Control

The control regulates the air temperature in the drawer. Set control level to **COLD** to provide normal refrigerator temperature. Use the **COLDER** setting for meats or other deli items.

NOTE: Cold air directed to the Glide'N'Serve can decrease refrigerator temperature. It may be necessary to adjust the refrigerator temperature.

To remove and replace Glide'N'Serve

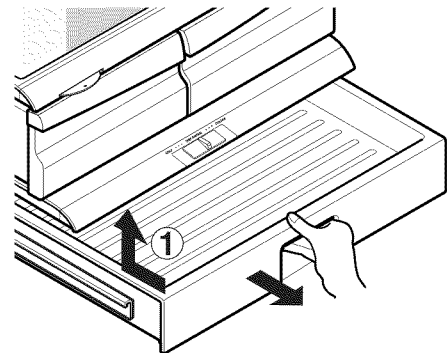

1. To remove, pull the drawer out to full extension.
2. Lift the front of the drawer up, then pull it straight out.
3. To install, slightly tilt up the front and insert the drawer into the frame and push it back into place.

USING YOUR REFRIGERATOR

MODULAR DOOR BIN

The door bins are removable for easy cleaning and adjusting.

1. To remove the bin, simply lift the bin up and pull straight out.
2. To replace the bin, slide it in above the desired support button and push down until it snaps into place.

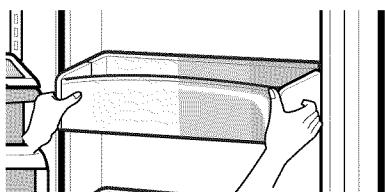

DAIRY BIN

1. To remove the dairy bin, simply lift it and pull straight out.
2. To replace the dairy bin, slide it in above the desired location and push down until it stops.

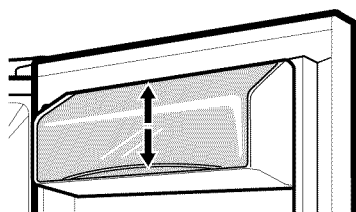

FREEZER SECTION

ICE BIN

1. To remove the ice bin from the upper drawer, pull out the drawer as far as possible.
2. Gently lift and pull out the ice bin.
3. To install, pull out the drawer as much as possible and set the ice bin in its correct position, then push in the drawer.

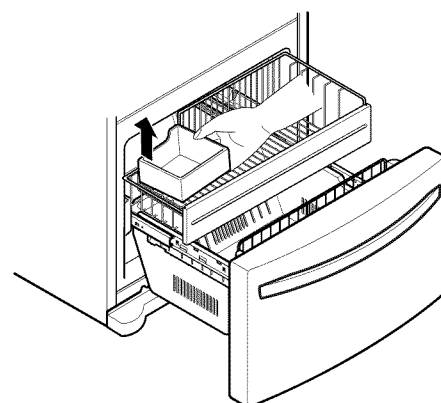
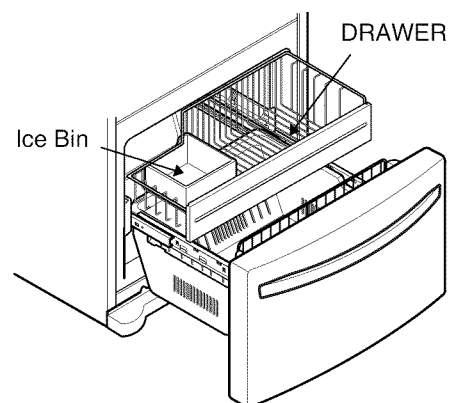

▲ CAUTION: Pinch hazard! Keep hands and feet clear of the bottom of the door when opening and closing.

USING YOUR REFRIGERATOR

TILT-OUT DOOR BASKET

To remove basket

1. Pull one of the brackets upward.
2. Remove basket from both brackets.

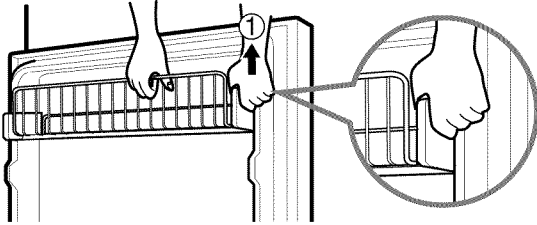

To replace basket

1. Insert bracket into one side. Hook end of basket into bracket.
2. Hook other basket end into other bracket. Push bracket down into place.
3. Be sure back of basket goes behind retention tab on each bracket.

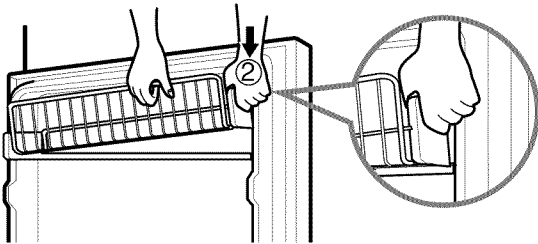

DURABASE

1. To remove the Durabase, push it to the back as much as possible. Tilt up the front of the Durabase and pull straight out.
2. To install, insert the Durabase into the rail assembly.

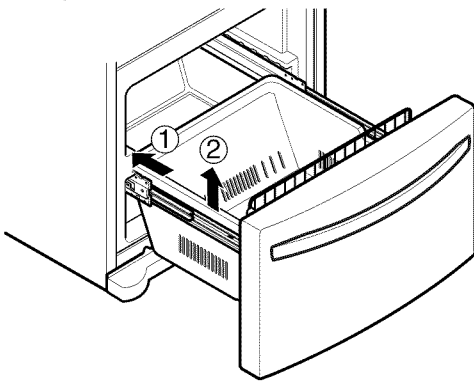

DURABASE DIVIDER

The Durabase divider allows you to organize the Durabase area into sections.

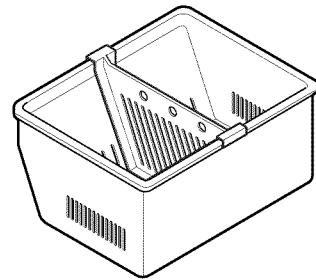

▲ WARNING: If the Durabase divider is removed, there is enough open space for children or pets to crawl inside.

To prevent accidental child and pet entrapment or suffocation risk, **DO NOT** allow them to go near or touch the freezer drawer.

PULLOUT DRAWER

To remove the drawer, push in the tabs (1) on both sides of the drawer and lift up on the front (2) and pull it straight out (3).

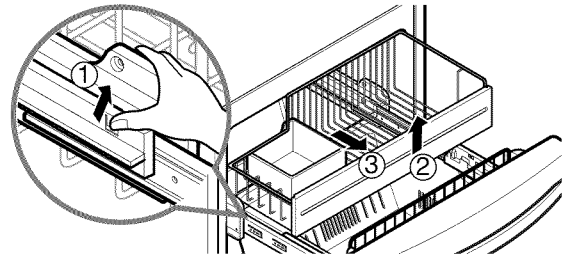

To install the drawer, pull out both rails to their full extension, raise the front of the drawer up and align the gears on the back of the drawer to rail assembly and gently push down on the front of the drawer until the tabs on each side snap into place.

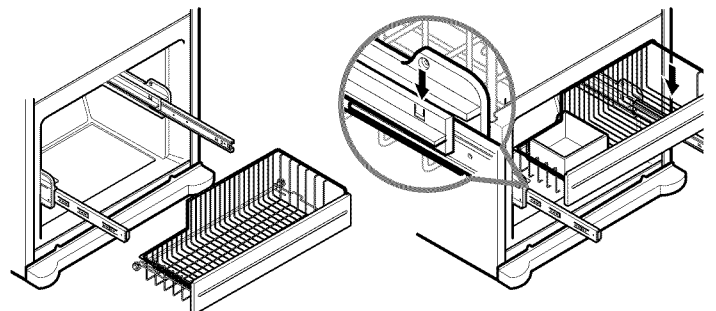

CARE AND CLEANING

⚠ WARNING



Explosion Hazard

Use non-flammable cleaner. Failure to do so can result in death, explosion, or fire.

Both the refrigerator and freezer sections defrost automatically. However, clean both sections about once a month to prevent odors. Wipe up spills immediately.

GENERAL CLEANING TIPS

- Unplug refrigerator or disconnect power.
- Remove all removable parts, such as shelves, crispers, etc. Refer to sections in Using Your Refrigerator for removal instructions.
- Use a clean sponge or soft cloth and a mild detergent in warm water. Do not use abrasive or harsh cleaners.
- Hand wash, rinse and dry all surfaces thoroughly.
- Plug in refrigerator or reconnect power.

OUTSIDE

Waxing external painted metal surfaces helps provide rust protection. Do not wax plastic parts. Wax painted metal surfaces at least twice a year using appliance wax (or auto paste wax). Apply wax with a clean, soft cloth.

For products with a stainless steel exterior, use a clean sponge or soft cloth and a mild detergent in warm water. Do not use abrasive or harsh cleaners. Dry thoroughly with a soft cloth.

INSIDE WALLS (allow freezer to warm up so the cloth will not stick)

To help remove odors, you can wash the inside of the refrigerator with a mixture of baking soda and warm water. Mix 2 tablespoons baking soda to 1 quart of water (26 g soda to 1 liter water.) Be sure the baking soda is completely dissolved so it does not scratch the surfaces of the refrigerator.

⚠ CAUTION: While cleaning the inside, do not spray water.

DOOR LINERS AND GASKETS

Do not use cleaning waxes, concentrated detergents, bleaches, or cleaners containing petroleum on plastic refrigerator parts.

PLASTIC PARTS (covers and panels)

Do not use window sprays, abrasive cleansers, or flammable fluids. These can scratch or damage the material.

CONDENSER COILS

Use a vacuum cleaner with an attachment to clean the condenser cover and vents.

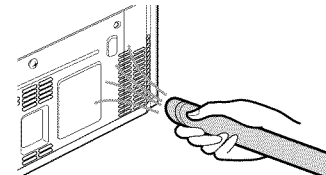

LIGHT BULB REPLACEMENT

⚠ WARNING

Electrical Shock Hazard

Before replacing a burned-out light bulb, either unplug the refrigerator or turn off power at the circuit breaker or fuse box.

NOTE: The refrigerator compartment has LED interior lighting and service should only be performed by a qualified technician.

CARE AND CLEANING

To change freezer light

NOTE: Some models have LED interior lighting and service should only be performed by a qualified technician.

1. Unplug refrigerator power cord from outlet.
2. Using a flat instrument, gently pry the lamp cover loose in the front as shown. Rotate downward to remove the rear tabs.
3. Make sure the light bulb is cool to the touch. Turn the bulb counterclockwise to remove.
4. Replace with a new 60-watt appliance bulb.
5. Insert tabs on back of cover into slots in freezer ceiling. Push cover up to snap front into place.

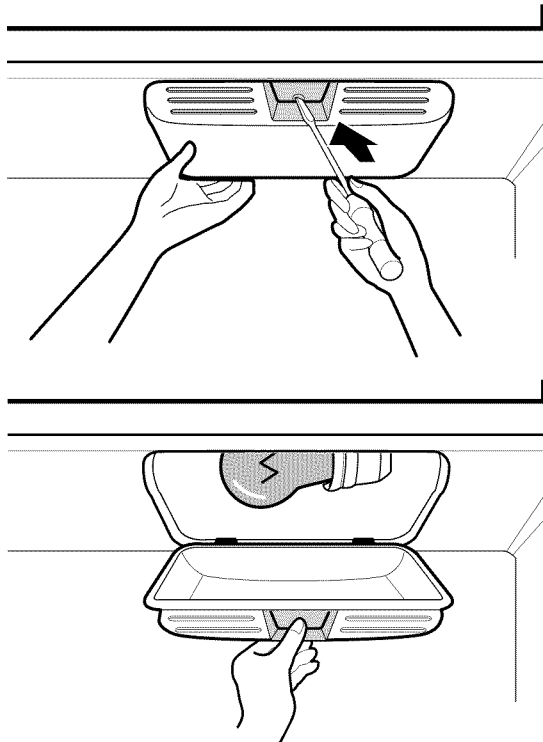

▲ CAUTION: DO NOT place fingers inside of cover. Lamp may be hot.

POWER INTERRUPTIONS

1. If the power will be out for 24 hours or less, keep all refrigerator doors closed to help foods stay cold and frozen.
2. If the power will be out for more than 24 hours, remove all the frozen food and store it in a frozen food locker.

WHEN YOU GO ON VACATION

If you choose to leave the refrigerator on while you are away, follow these steps to prepare your refrigerator before you leave.

1. Use up any perishables and freeze other items.
2. Turn off icemaker and empty the ice bin.

If you choose to turn the refrigerator off before you leave, follow these steps.

1. Remove all food from the refrigerator.
2. Unplug the refrigerator.
3. Clean refrigerator, wipe it and dry well.
4. Tape rubber or wood blocks to the tops of both doors to prop them open far enough for air to get in. This stops odor and mold from building up.

WHEN YOU MOVE

When you are moving your refrigerator to a new home, follow these steps to prepare it for the move.

1. Remove all food from the refrigerator and pack all frozen food in dry ice.
2. Unplug the refrigerator.
3. Clean, wipe and dry thoroughly.
4. Take out all removable parts, wrap them well and tape them together so they do not shift and rattle during the move. Refer to sections in **Using your Refrigerator** for removable instructions.
5. Screw in the leveling legs all the way so they do not scrape the floor. See the **Door Closing** section.
6. Tape the doors shut and tape the power cord to the refrigerator cabinet.

When you get to your new home, put everything back and refer to the **Installing Your Refrigerator** section for preparation instructions.

ABOUT THE AUTOMATIC ICEMAKER

⚠ WARNING

Personal Injury Hazard

DO NOT place fingers or hands in the automatic icemaking mechanism while the refrigerator is plugged in.

OPERATION INSTRUCTIONS

A newly-installed refrigerator may take 12 to 24 hours to begin making ice.

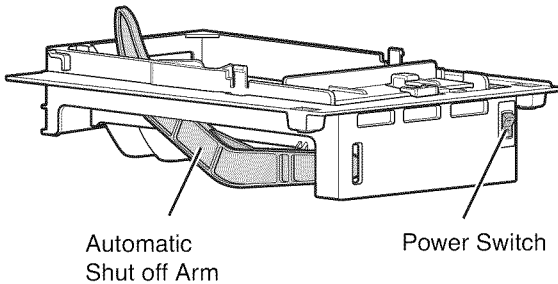

The icemaker will produce 12 cubes per cycle—approximately 100 cubes in a 24-hour period, depending on freezer compartment temperature, room temperature, number of door openings and other operating conditions.

If the refrigerator is used before the water connection is made to the icemaker, set the power switch to **Off (O)**.

When the refrigerator has been connected to the water supply, set the power switch to **On (I)**.

The icemaker will fill with water when it cools to freezing. A newly-installed refrigerator may take 12 to 24 hours to begin making ice cubes.

Discard the first few batches of ice to allow the water line to clear.

Be sure nothing interferes with the sweep of the Automatic Shut off Arm.

When the bin fills to the level of the Automatic Shut off Arm, the icemaker will stop producing ice.

It is normal for several cubes to be stuck together.

If ice is not used frequently, old ice cubes will become cloudy, taste stale, and shrink.

WHEN YOU SHOULD SET THE ICEMAKER POWER SWITCH TO OFF (O)

- When the water supply will be shut off for several hours.
- When the ice storage bin is removed for more than a minute or two.
- When the refrigerator will not be used for several days.

NORMAL SOUNDS YOU MAY HEAR

- The icemaker water valve will buzz as the icemaker fills with water.
NOTE: If the house water supply (cold water only) is not hooked up or not turned on fully, turn the icemaker to the **Off (O)** position to prevent noise and possible damage. Do not turn the icemaker **On (I)** until an adequate water supply is connected.
- You will hear the sound of cubes dropping into the bin and water running in the pipes as the icemaker refills.

PREPARING FOR VACATION

Set the icemaker power switch to **Off (O)** and shut off the water supply to the refrigerator.

If the ambient temperature will drop below freezing, have a qualified servicer drain the water supply system to prevent serious property damage due to flooding from ruptured water lines or connections.

CONNECTING THE WATER LINE

BEFORE YOU BEGIN

This water line installation is not warranted by the refrigerator or icemaker manufacturer or retailer. Follow these instructions carefully to minimize the risk of expensive water damage.

Water hammer (water banging in the pipes) in house plumbing can cause damage to refrigerator parts and lead to water leakage or flooding. Call a qualified plumber to correct water hammer before installing the water supply line to the refrigerator.

To prevent burns and product damage, do not hook up the water line to the hot water line.

If you use your refrigerator before connecting the water line, make sure the icemaker power switch is in the **Off (O)** position.

Do not install the icemaker tubing in areas where temperatures fall below freezing.

When using any electrical device (such as a power drill) during installation, be sure the device is double-insulated or grounded in a manner to prevent the hazard of electric shock, or is battery-powered.

If a **reverse osmosis water filtration system** is connected to your cold water supply, this water line installation is not warranted by the refrigerator or icemaker manufacturer or retailer. Follow next instructions carefully to minimize the risk of expensive water damage.

If a **reverse osmosis water filtration system** is connected to your cold water supply, the water pressure to the reverse osmosis system needs to be a minimum of 40 to 60 psi (2.8 kgf/cm² ~ 4.2 kgf/cm², less than 2.0~3.0sec to fill a cup of 7oz capacity).

If the water pressure from the reverse osmosis system is less than 21 psi (1.5 kgf/cm², more than 4.0sec to fill a cup of 7oz capacity):

Check to see whether the sediment filter in the reverse osmosis system is blocked. Replace the filter if necessary.

Allow the storage tank on the reverse osmosis system to refill after heavy usage.

If the issue about water pressure from reverse osmosis remains, call a licensed, qualified plumber.

All installations must be in accordance with local plumbing code requirements.

NOTE: Wear eye protection.

WHAT YOU WILL NEED

- **Copper Tubing**, 1/4" outer diameter to connect the refrigerator to the water supply. Be sure both ends of the tubing are cut square.

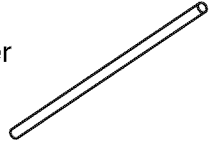

To determine how much tubing you need, measure the distance from the water valve on the back of the refrigerator to the water supply pipe. Then add 8 feet (2.4 m). Be sure there is sufficient extra tubing (about 8 feet [2.4 m] coiled into 3 turns of about 10" [25 cm] diameter) to allow the refrigerator to move out from the wall after installation.

- **A cold water supply.** The water pressure must be between 20 and 120 p.s.i. on models without a water filter and between 40 and 120 p.s.i. on models with a water filter.

- **Power drill.**

- **1/2" or adjustable wrench.**

- **Straight- and Phillips-blade screwdriver.**

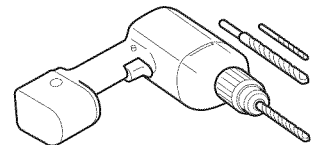

- **Two 1/4" outer diameter compression nuts and 2 ferrules (sleeves)** to connect the copper tubing to the shutoff valve and the refrigerator water valve.

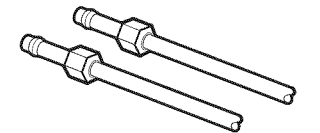

- If your existing copper water line has a flared fitting at the end, you will need an **adapter** (available at plumbing supply stores) to connect the water line to the refrigerator OR you can cut off the flared fitting with a tube cutter and then use a compression fitting.

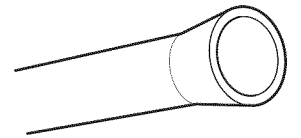

- **Shutoff valve to connect to the cold water line.**

The shutoff valve should have a water inlet with a minimum inside diameter of 5/32" at the point of connection to the COLD WATER LINE. Saddle-type shutoff valves are included in many water supply kits. Before purchasing, make sure a saddle-type valve complies with your local plumbing codes.

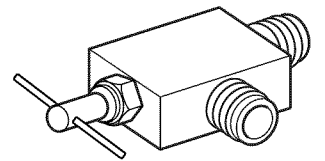

NOTE: Self Piercing Saddle Type Water Valve should not be used.

CONNECTING THE WATER LINE

INSTALLATION INSTRUCTIONS

Install the shutoff valve on the nearest frequently used drinking water line.

1. SHUT OFF THE MAIN WATER SUPPLY

Turn on the nearest faucet to relieve the pressure on the line.

2. CHOOSE THE VALVE LOCATION

Choose a location for the valve that is easily accessible. It is best to connect into the side of a vertical water pipe. When it is necessary to connect into a horizontal water pipe, make the connection to the top or side, rather than at the bottom, to avoid drawing off any sediment from the water pipe.

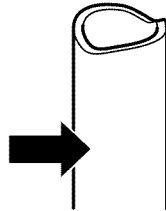

3. DRILL THE HOLE FOR THE VALVE

Drill a 1/4" hole in the water pipe using a sharp bit. Remove any burrs resulting from drilling the hole in the pipe. Take care not to allow water to drain into the drill. Failure to drill a 1/4" hole may result in reduced ice production or smaller cubes.

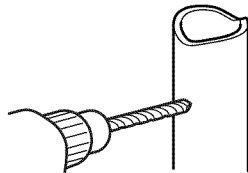

NOTE: The hookup line cannot be white, plastic tubing. Licensed plumbers must use only copper tubing NDA tubing #49595 or 49599 or Cross Link Polyethylene(PEX) tubing.

4. FASTEN THE SHUTOFF VALVE

Fasten the shutoff valve to the cold water pipe with the pipe clamp.

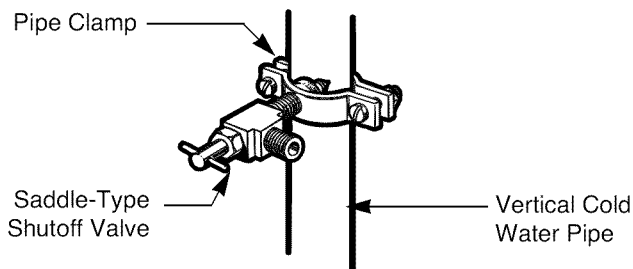

NOTE: Commonwealth of Massachusetts Plumbing Codes 248CMR shall be adhered to. Saddle valves are illegal and use is not permitted in Massachusetts. Consult with your licensed plumber.

5. TIGHTEN THE PIPE CLAMP

Tighten the clamp screws until the sealing washer begins to swell.

NOTE: Do not overtighten or you may crush the tubing.

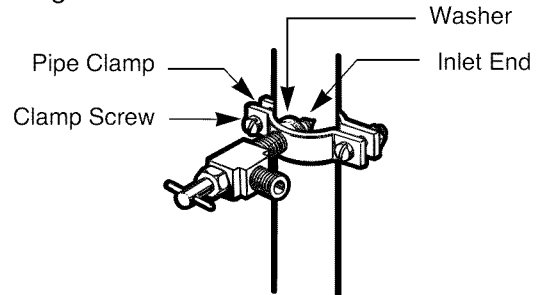

6. ROUTE THE TUBING

Route the tubing between the cold water line and the refrigerator.

Route the tubing through a hole drilled in the wall or floor (behind the refrigerator or adjacent base cabinet) as close to the wall as possible.

NOTE: Be sure there is sufficient extra tubing (about 8 feet coiled into 3 turns of about 10" diameter) to allow the refrigerator to move out from the wall after installation.

7. CONNECT THE TUBING TO THE VALVE

Place the compression nut and ferrule (sleeve) for copper tubing onto the end of the tubing and connect it to the shutoff valve. Make sure the tubing is fully inserted into the valve. Tighten the compression nut securely.

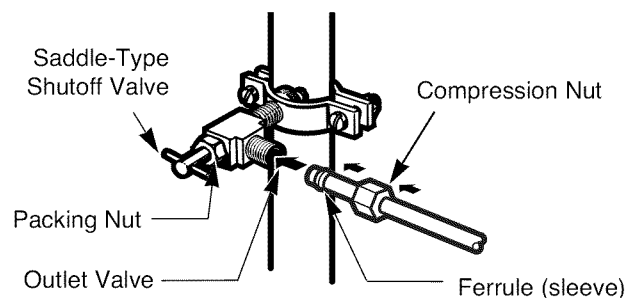

NOTE: Commonwealth of Massachusetts Plumbing Codes 248CMR shall be adhered to. Saddle valves are illegal and use is not permitted in Massachusetts. Consult with your licensed plumber.

CONNECTING THE WATER LINE

8. FLUSH OUT THE TUBING

Turn the main water supply on and flush out the tubing until the water is clear.

Shut the water off at the water valve after about one quart of water has been flushed through the tubing.

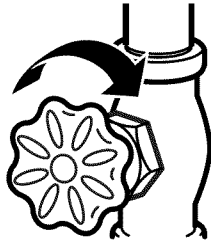

10. TURN THE WATER ON AT THE SHUTOFF VALVE

Tighten any connections that leak.

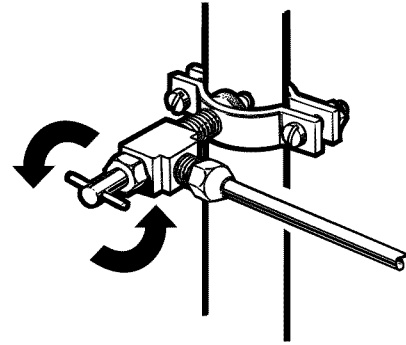

9. CONNECT THE TUBING TO THE REFRIGERATOR

NOTE:

• Before making the connection to the refrigerator, be sure the refrigerator power cord is not plugged into the wall outlet.

1. Remove the plastic flexible cap from the water valve.
2. Place the compression nut and ferrule (sleeve) onto the end of the tubing as shown.
3. Insert the end of the copper tubing into the connection as far as possible. While holding the tubing, tighten the fitting.

▲ CAUTION: Check to see if leaks occur at water line connections.

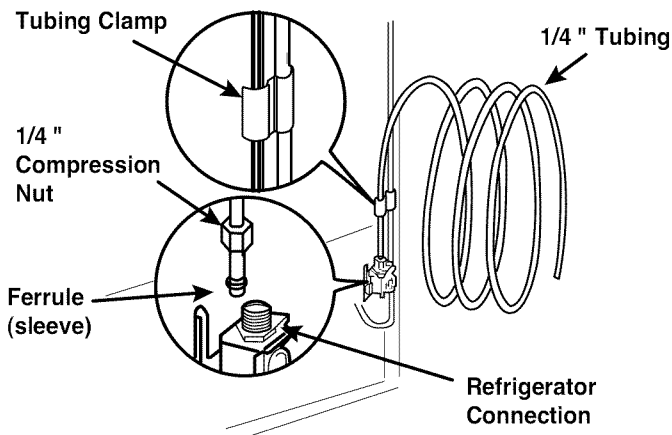

▲ CAUTION: Check to see if water dripping occurs at water line connections.

11. PLUG IN THE REFRIGERATOR

Arrange the coil of tubing so that it does not vibrate against the back of the refrigerator or against the wall. Push the refrigerator back to the wall.

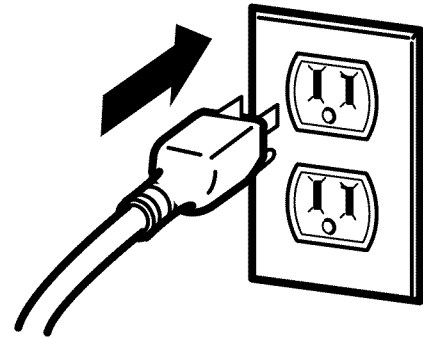

12. START THE ICEMAKER

Set the icemaker power switch to the **On (I)** position.

NOTE: A newly installed refrigerator may take several hours to start producing ice.

TROUBLESHOOTING GUIDE

UNDERSTANDING SOUNDS YOU MAY HEAR

Your new refrigerator may make sounds that your old one did not make. Because the sounds are new to you, you might be concerned about them. Most of the new sounds are normal. Hard surfaces, like the floor, walls and cabinets, can make the sounds seem louder than they actually are. The following list describes the kinds of sounds and what may be making them.

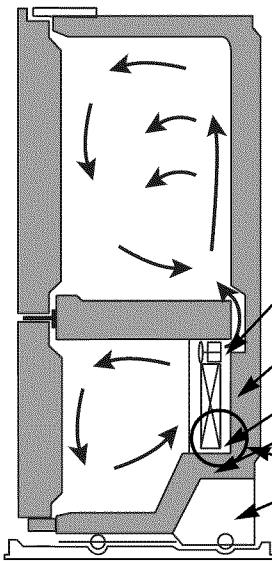

- A clicking noise may come from the electronic control switching the cooling system on and off.
- Rattling noises may come from the flow of refrigerant, the water line, or items stored on top of the refrigerator.
- Your refrigerator is designed to run more efficiently to keep your food items at the desired temperature. The high efficiency compressor may cause your new refrigerator to run longer than your old one, but is still more energy efficient than previous models. While running, you may hear a pulsating or high-pitched sound, this is normal.
- You may hear the evaporator fan motor circulating the air through the refrigerator and freezer compartments.
- As each cycle ends, you may hear a gurgling sound due to the refrigerant flowing in your refrigerator.
- Contraction and expansion of the inside walls may cause a popping noise.
- Water dripping on the defrost heater during a defrost cycle may cause a sizzling sound.
- You may hear air being forced over the condenser by the condenser fan.
- You may hear water running into the drain pan during the defrost cycle.
- You can hear the noise occurring from the ice compartment fan in the freezer or the left side of the refrigerator when doors are open.

REFRIGERATOR DOES NOT OPERATE

Check if...

Then...

The power supply cord is unplugged.	Firmly plug the cord into a live outlet with proper voltage.
A household fuse has blown or circuit breaker tripped.	Replace the fuse or reset the circuit breaker. Check that the house circuit is not overloaded.
Refrigerator is in the defrost cycle.	Wait about 30 minutes for defrost cycle to end.
Store salesfloor Demonstration Mode. 	The refrigerator control has been put into the store Demo (Demonstration) Mode. The Demonstration Mode disables the cooling system, only lamps and display work normally. To disable open one door, then press Ultra Ice and Refrigerator Temp buttons at the same time for 5 seconds. You will see the previous value setting you had on display when Demo Mode is deactivated.

TROUBLESHOOTING GUIDE

LIGHTS DO NOT WORK

Check if...

Then...

The power supply cord is unplugged.	Firmly plug the cord into a live outlet with proper voltage.
Light bulb is loose in the socket.	Unplug the refrigerator. Gently remove the bulb and reinsert. Then plug in the refrigerator and reset the refrigerator control.
Light bulb has burned out.	Replace with an appliance bulb of the same wattage, size and shape available at your local hardware store. (See the Changing the Light Bulb(s) section on pages 25-26.) Unplug the refrigerator prior to replacement.
The door has been open for seven minutes.	Shutting doors for one second will cause the light bulbs to come back on.

VIBRATION OR RATTLING NOISE

Check if...

Then...

The refrigerator is not resting solidly on the floor.	Floor is weak or uneven or leveling legs need adjusting. See Installation section on pages 9 and 17.
---	---

COMPRESSOR MOTOR SEEMS TO RUN TOO MUCH

Check if...

Then...

The refrigerator that was replaced was an older model.	The high efficiency compressor may cause your new refrigerator to run more than your older one, but is still more energy efficient than previous models.
The room temperature is hotter than normal.	The motor will run longer under warm conditions. At normal room temperatures, expect your motor to run about 40% to 80% of the time. Under warmer conditions, expect it to run even more often.
The door is opened often or a large amount of food has just been added.	Adding food and opening the door warms the refrigerator. It is normal for the refrigerator to run longer in order to cool the refrigerator back down. See the Food Storage Guide section on page 20. In order to conserve energy, try to get everything you need out of the refrigerator at once, keep food organized so it is easy to find and close the door as soon as the food is removed.
The refrigerator was recently plugged in and the refrigerator control was set correctly.	The refrigerator will take up to 24 hours to cool completely.
The refrigerator control is not set correctly for the surrounding conditions.	See the Adjusting Control Settings section on page 19.
The doors are not closed completely.	Push the doors firmly shut. If they will not shut all the way, see DOORS WILL NOT CLOSE COMPLETELY on page 33.
The back cover is dirty.	A dirty back cover prevents air transfer and makes the motor work harder. Clean the back cover. Refer to the Care and Cleaning section on page 25-26.

TROUBLESHOOTING GUIDE

DOORS WILL NOT CLOSE COMPLETELY

Check if...	Then...
The refrigerator is not level.	See Leveling and Door Alignment section on page 17.
Food packages are blocking the door open.	Rearrange food containers to clear door and door shelves.
The ice bin, crisper cover, pans, shelves, door bins or baskets are out of position.	Push bins all the way in and put crisper cover, pans, shelves and baskets into their correct positions. See the Using Your Refrigerator section on pages 18–24.
The gaskets are sticking.	Clean the gaskets and the surfaces that they touch. Rub a thin coat of appliance polish or kitchen wax on the gaskets after cleaning.
The refrigerator wobbles or seems unstable.	Level the refrigerator. Refer to the Leveling and Door Alignment section on page 17.
The doors were removed during product installation and not properly replaced.	Remove and replace the doors according to the Removing and Replacing Refrigerator handles and doors section on pages 11–16, or call a qualified service technician.

FROST OR ICE CRYSTALS ON FROZEN FOOD

Check if...	Then...
The door is not closing properly.	See DOORS WILL NOT CLOSE COMPLETELY above.
The door is opened often.	When the door is opened, warm, humid air is allowed in the freezer, resulting in frost.

ICE HAS BAD TASTE OR ODOR

Check if...	Then...
The icemaker was recently installed.	Discard the first few batches of ice to avoid discolored or bad tasting ice.
The ice has been stored for too long.	Throw away old ice and make a new supply.
The food has not been wrapped tightly in either compartment.	Rewrap foods since odors may migrate to the ice if food is not wrapped properly.
The water supply contains minerals such as sulfur.	A filter may need to be installed to eliminate taste and odor problems.
The interior of refrigerator needs cleaning.	See Care and Cleaning section on pages 25-26.
Ice storage bin needs cleaning.	Empty and wash bin. Discard old cubes.

THERE IS WATER IN THE DEFROST DRAIN PAN

Check if...	Then...
The refrigerator is defrosting.	The water will evaporate. It is normal for water to drip into the defrost pan.
It is more humid than normal.	Expect that the water in the defrost pan will take longer to evaporate. This is normal when it is hot or humid.

TROUBLESHOOTING GUIDE

THE REFRIGERATOR SEEMS TO MAKE TOO MUCH NOISE

Check if...

Then...

The sounds may be normal for your refrigerator.	Refer to the Understanding Sounds You May Hear section on page 31.
---	---

THE ICEMAKER IS NOT PRODUCING ICE OR NOT ENOUGH ICE

Check if...

Then...

New installation.	Wait 24 hours after ice maker installation for ice production to begin. Wait 72 hours for full ice production.
The refrigerator is not connected to a water supply or the supply shutoff valve is not turned on.	Connect refrigerator to the water supply and turn water shutoff valve fully open.
Reverse osmosis water filtration system is connected to your cold water supply.	Reverse osmosis filtration systems can reduce the water pressure below the minimum amount (20 psi) and result in icemaker issues.
Kink in the water source line.	A kink in the line can reduce water flow. Straighten the water source line.
Large amount of ice recently has been removed.	Allow 24 hours for ice maker to produce more ice.
The icemaker is not turned on.	Locate the icemaker on/off switch and confirm it is in the On (I) position.
There is something on the ice-detecting sensor.	Foreign substances or frost on the ice-detecting sensor can interrupt ice production. Make sure the sensor area is clean at all times for proper operation.
The temperature setting for the freezer is too warm.	Below 0°F is the recommended temperature for the freezer compartment for normal ice production. If the freezer temperature is warmer, ice production will be affected.
The doors are opened often.	If the doors of the unit are opened often, the cold air will escape which will prevent the unit from maintaining the set temperature. Lowering the temperature can help, as well as not opening the doors as frequently.
The doors are not closing properly.	If the doors are not properly closed, ice production will be affected.
The ice compartment door is not closing properly.	If the ice compartment door is not properly closed, ice production will be affected. Make sure ice compartment door is closed for proper operation.
Ultra Ice is not selected.	With this option, the cold air in the compartment is increased as is ice production.

TROUBLESHOOTING GUIDE

THE DOORS ARE DIFFICULT TO OPEN

Check if...

Then...

The gaskets are dirty or sticky.	Clean the gaskets and the surfaces that they touch. Rub a thin coat of appliance polish or kitchen wax on the gaskets after cleaning.
The door is reopened within a short time after having been opened.	When you open the door, warmer air enters the refrigerator. As the warm air cools, it can create a vacuum. If the door is hard to open, wait 5 minutes to allow the air pressure to equalize, then see if it opens more easily.

TEMPERATURE IS TOO WARM OR THERE IS INTERIOR MOISTURE BUILDUP

Check if...

Then...

The air vents are blocked. Cold air circulates from the freezer to the fresh food section and back again through air vents in the wall dividing the two sections.	Locate air vents by using your hand to sense airflow and move all packages that block vents and restrict airflow. (See air flow diagram below).
The doors are opened often.	When the door is opened, warm humid air is allowed into the refrigerator. The more the door is opened, the faster the humidity builds up, and the more warm air the refrigerator must cool. In order to keep the refrigerator cool, try to get everything you need out of the refrigerator at once, keep food organized so it is easy to find and close the door as soon as the food is removed.
The control is not set correctly for the surrounding conditions.	Refer to the Setting the Controls section on page 18. Wait 24 hours for temperatures to stabilize or even out. If the temperature is too cold or too warm, change the setting one increment at a time.
A large amount of food has just been added to the refrigerator or freezer.	Adding food warms the refrigerator. It can take a few hours for the refrigerator to return to normal temperature.
The food is not packaged correctly.	Wrap food tightly and wipe off damp containers prior to storing in the refrigerator to avoid moisture accumulation. If necessary, repackage food according to the guidelines in the Food Storage Guide section on page 20.
The doors are not closing completely.	See DOORS WILL NOT CLOSE COMPLETELY on page 33.
The weather is humid.	In humid weather, air carries moisture into the refrigerator when the doors are opened.
A self-defrost cycle was completed.	It is normal for droplets to form on the back wall after the refrigerator self-defrosts.

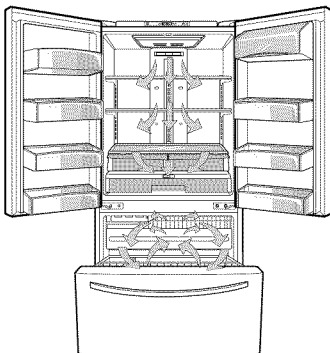

Get it fixed, at your home or ours!

Your Home

For troubleshooting, product manuals and home solutions advice:



www.managemylife.com

For repair – **in your home** – of **all** major brand appliances, lawn and garden equipment, or heating and cooling systems, **no matter who made it, no matter who sold it!**

For the replacement parts, accessories and owner's manuals that you need to do-it-yourself.

For Sears professional installation of home appliances and items like garage door openers and water heaters.

1-800-4-MY-HOME[®] (1-800-469-4663)

Call anytime, day or night (U.S.A. and Canada)

www.sears.com www.sears.ca

Our Home

For repair of carry-in items like vacuums, lawn equipment, and electronics, call anytime for the location of your nearest

Sears Parts & Repair Service Center

1-800-488-1222 (U.S.A.) **1-800-469-4663** (Canada)

www.sears.com

www.sears.ca

To purchase a protection agreement on a product serviced by Sears:

1-800-827-6655 (U.S.A.)

1-800-361-6665 (Canada)

Para pedir servicio de reparación a domicilio, y para ordenar piezas:

1-888-SU-HOGAR[®]

(1-888-784-6427)

www.sears.com

Au Canada pour service en français:

1-800-LE-FOYER^{MC}

(1-800-533-6937)

www.sears.ca

The Sears logo, featuring the word "Sears" in a large, stylized, serif font with a distinctive 'S'.