

This Owner's Manual is provided and hosted by [Appliance Factory Parts](http://ApplianceFactoryParts.com).



KITCHENAID 5KWB100EPM0 Owner's Manual

[Shop genuine replacement parts for KITCHENAID
5KWB100EPM0](#)

CONTROL PANEL PARTS For Models: 5KWB100B_0

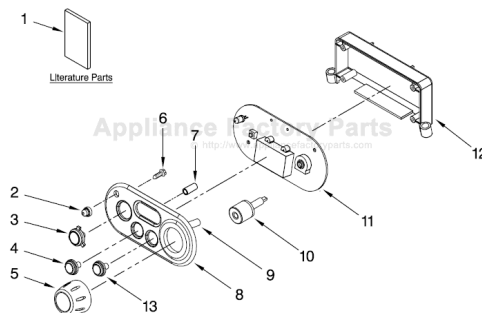

[Find Your KITCHENAID Small Appliance Parts - Select From 538 Models](#)

----- Manual continues below -----

KitchenAid®

ARTISAN® WAFELMACHINE
INSTRUCTIES EN RECEPTEN

ARTISAN® WAFFLE BAKER
INSTRUCTIONS AND RECIPES

GAUFRIER ARTISAN®
MODE D'EMPLOI ET RECETTES

ARTISAN® WAFFELEISEN
BEDIENUNGSANLEITUNG UND REZEPTE

WAFFLE BAKER ARTISAN®
ISTRUZIONI PER L'USO E RICETTE

GOFRERA ARTISAN®
INSTRUCCIONES Y RECETAS

ARTISAN® VÅFFELJÄRN
INSTRUKTIONER OCH RECEPT

ARTISAN® VAFFELJERN
INSTRUKSJONER OG OPPSKRIFTER

ARTISAN® VOHVELIRAUTA
KÄYTTÖ-JA VALMISTUSOHJEET

ARTISAN®-VAFFELBAGER
INSTRUKTIONER OG OPSKRIFTER

ARTISAN® WAFFLE BAKER
INSTRUÇÕES E RECEITAS

ARTISAN® VÖFFLUJÁRN
LEIÐBEINGAR OG UPPSKRIFTIR

ΜΗΧΑΝΗ ΓΙΑ ΒΑΦΛΕΣ
ARTISAN®
ΟΔΗΓΙΕΣ ΚΑΙ ΣΥΝΤΑΓΕΣ

English



Model 5KWB100
Artisan® Waffle Baker

Table of Contents

Waffle Baker Safety.....	1
Electrical Requirements	1
Important Safeguards	2
Waffle Baker Features	3
Using the Waffle Baker	5
First Use of the Waffle Baker.....	5
Operating the Waffle Baker	5
Cancelling a Baking Timer Countdown	8
Recipe Tips.....	8
Baking & Serving Tips	9
Cleaning the Waffle Baker.....	9
Troubleshooting.....	10
Recipes	
Banana and Walnut Waffles	11
Chocolate Chip Waffles	12
Brussels Hot Waffles	12
Chantilly Waffles.....	13
Liège Waffles.....	13
Waffles with Cinnamon	14
4/4 Waffles.....	14
Soft Vanilla Waffles	15
Waffles with Almonds	15
Delicious Waffles with Beer.....	16
Belgian Waffles.....	16
Warranty and Service Information	
KitchenAid® Artisan® Waffle Baker Warranty	17
Service Centers	17
Customer Service.....	17

Waffle Baker Safety

Your safety and the safety of others are very important.

We have provided many important safety messages in this manual and on your appliance. Always read and obey all safety messages.



This is the safety alert symbol.

This symbol alerts you to potential hazards that can kill or hurt you and others.

All safety messages will follow the safety alert symbol and either the word "DANGER" or "WARNING." These words mean:

⚠ DANGER

You can be killed or seriously injured if you don't immediately follow instructions.

⚠ WARNING

You can be killed or seriously injured if you don't follow instructions.

All safety messages will tell you what the potential hazard is, tell you how to reduce the chance of injury, and tell you what can happen if the instructions are not followed.

Electrical Requirements

Model 5KWB100:

230-240 Volts A.C.
Hertz: 50 Hz

NOTE: Model 5KWB100 has a grounded plug. To reduce the risk of electrical shock, this plug will fit in an outlet only one way. If the plug does not fit in the outlet, contact a qualified electrician. Do not modify the plug in any way.

Do not use an extension cord. If the power supply cord is too short, have a qualified electrician or serviceman install an outlet near the appliance.

⚠ WARNING



Electrical Shock Hazard

Plug into a grounded outlet.

Do not remove ground prong.

Do not use an adapter.

Do not use an extension cord.

Failure to follow these instructions can result in death, fire, or electrical shock.

IMPORTANT SAFEGUARDS

When using electrical appliances, basic safety precautions should always be followed to reduce the risk of fire, electric shock, and/or injury to persons including the following:

1. Read all instructions.
2. Do not touch hot surfaces. Use handles or knobs.
3. To protect against electrical shock, do not immerse cord, plugs, or Waffle Baker in water or other liquids.
4. Unplug Waffle Baker from outlet when not in use and before cleaning. Allow to cool before putting on or taking off parts.
5. Do not operate any appliance with a damaged cord or plug, or after the appliance malfunctions or has been damaged in any manner. Return appliance to the nearest authorized service facility for examination, repair, or adjustment.
6. The use of accessory attachments not recommended by KitchenAid may cause injuries.
7. Do not use outdoors.
8. Do not let cord hang over edge of table or counter, or touch hot surfaces.
9. Do not place on or near a hot gas or electric burner, or in a heated oven.
10. When finished baking waffles, press the On/Off Button to turn the Waffle Baker off, then remove plug from outlet.
11. Do not use appliance for other than intended use.
12. The appliance is not intended for use by persons (including children) with reduced physical, sensory or mental capabilities, or lack of experience and knowledge, unless they have been given supervision or instruction concerning use of the appliance by a person responsible for their safety.
13. Young children should be supervised to ensure that they do not play with the appliance.
14. This product is designed for household and commercial use.

SAVE THESE INSTRUCTIONS

This appliance is marked according to the European directive 2002/96/EC on Waste Electrical and Electronic Equipment (WEEE).

By ensuring this product is disposed of correctly, you will help prevent potential negative consequences for the environment and human health, which could otherwise be caused by inappropriate waste handling of this product.



The symbol  on the product, or on the documents accompanying the product, indicates that this appliance may not be

treated as household waste. Instead it shall be handed over to the applicable collection point for the recycling of electrical and electronic equipment.

Disposal must be carried out in accordance with local environmental regulations for waste disposal.

For more detailed information about treatment, recovery and recycling of this product, please contact your local city office, your household waste disposal service or the shop where you purchased the product.

Waffle Baker Features



**Model 5KWB100
Artisan® Waffle Baker**



Commercial-Design Baking Unit

Double-sided, clamshell baking unit rotates to provide consistent waffles with minimal gaps and spaces.

Baker lids are brushed stainless steel; thermoset phenolic lid handles remain cool to the touch.



Die-Cast Metal Base

The durable metal base provides a stable platform for the baking unit.



Non-Stick Waffle Plates

Plates wipe clean with a paper towel or damp cloth. Drip channel along edge helps prevent overflow and spills.



Dial Thermometer

Thermometer in baker lid indicates the baker is ready when the needle position is within the thick line area.

Waffle Baker Features



Power Button (⏻)

Pressing the power button (⏻) turns the baking unit heating elements on or off. When the baker is on, the indicator light will be illuminated.



Pre-Heat Indicator

The indicator light flashes until the baker is fully pre-heated. When the optimum temperature is reached, a tone will sound and the indicator light will glow continuously.



Timer Adjustment Dial (⌚)

Turn the dial to set the baking time in 15 second increments, from a minimum of 2 minutes, 30 seconds

to a maximum of 5 minutes, 30 seconds. Turn the dial clockwise to increase the baking time, counter-clockwise to decrease the time.



Baking Timer Display

Shows the remaining baking time in minutes and seconds.



Start Button (▶)

Once the Waffle Baker is pre-heated, press the start button (▶) to begin a timer countdown.



Reset Button (↺)

After the baking timer is activated, press the reset button (↺) to stop the count and reset the baking timer display.

Pressing the reset button will also halt the message tones after the timer reaches zero.

Overbake Indication

When the baking timer reaches zero, the Waffle Baker produces a series of tones, the timer display background turns red, and the timer begins to count up. If your waffles are not quite done, the count-up will track the extra time you let the waffles bake.

Automatic Shutoff

Unless the baking timer is reset, the baking unit will automatically shut off 5 minutes after the timer reaches zero. After the baking timer is reset, the baking unit is programmed to shut off in 2 hours if a new timer countdown isn't started.

Timer Memory

Baking timer will remember the last time set, even when the baker is unplugged.

Message Tones

Convenient tones instantly convey Waffle Baker status. A tone will sound when the baker is fully pre-heated. When the baking timer reaches zero, the baker will produce a series of tones.

Constant Temperature Baking

Baker has no adjustable thermostat: waffles bake at a constant temperature optimized for the best results. Browning of waffle is controlled with the baking timer.

Using the Waffle Baker

First Use of the Waffle Baker

The Waffle Baker may emit a slight odor or smoke the first time it is used. This is a normal result of the manufacturing process. The odor or smoke is harmless and will dissipate quickly, but it may flavor the first waffle prepared on each side of the baker. For the best results, it is recommended that these initial waffles be discarded.

Steam will be produced during every baking cycle and condensation may form on the baker lids. This is normal.

NOTE: Always use the handles to rotate the baking unit and open the baking lids.

⚠️ WARNING



Electrical Shock Hazard

- Plug into a grounded outlet.**
- Do not remove ground prong.**
- Do not use an adapter.**
- Do not use an extension cord.**
- Failure to follow these instructions can result in death, fire, or electrical shock.**

Operating the Waffle Baker

1. Plug the Waffle Baker cord into a grounded outlet.

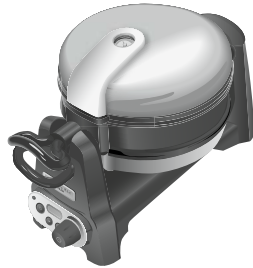

2. Rotate the baking unit so the baker lid with the dial thermometer faces upwards.
3. Press the Power Button (⏻) to turn the baking unit on. The indicator light will flash and the Waffle Baker will begin heating.



Using the Waffle Baker

4. Wait for the Waffle Baker to pre-heat. When the Waffle Baker has reached operating temperature, a tone will sound and the indicator light will stop flashing and glow continuously. The needle position on the dial thermometer will also be within the thick line area.



5. Set the baking timer by turning the Timer Adjustment Dial (⌚). Rotate the dial clockwise to increase the time on the baking timer display; rotate the dial counter-clockwise to decrease the time. The baking time can be set in 15 second increments from a minimum of 2 minutes, 30 seconds (2:30) to a maximum of 5 minutes, 30 seconds (5:30). Longer baking times will produce darker, crispier waffles. For your first waffles, a good starting time is 3 minutes, 30 seconds (3:30).



6. Open the baker lid by lifting the topmost handle. Make certain the lid is securely seated against the base before releasing the handle: if this is not done, the baking unit may rotate unexpectedly when the handle is released.



7. Fill the waffle plate evenly with batter. The batter should almost cover the peaks of the waffle grid. Close the baker lid.
- NOTE:** Do not use metal utensils with the Waffle Baker. Metal may scratch the non-stick waffle plates.

Using the Waffle Baker

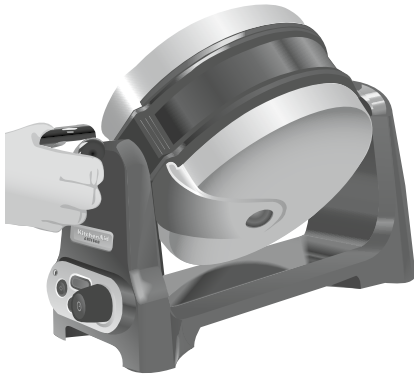

8. Rotate the baking unit so the opposite lid is topmost.

NOTE: Whether one or two waffles are being prepared, always rotate the baking unit after filling a waffle plate. This coats both the upper and lower waffle plates with batter and ensures the finest consistency.



9. Press the Start Button (▶) to begin the baking timer countdown.

NOTE: The Start Button (▶) will not activate a timer countdown unless the Waffle Baker is fully pre-heated.

10. If a second waffle is desired, open the baker lid and fill the waffle plate evenly with batter. Close the baker lid.
11. Rotate the baking unit so the lid with the dial thermometer again faces upward.
12. When the baking timer display reaches zero, a series of tones will sound, the baking timer display background will turn red, and the timer will begin to count up.



13. Open the baker lid and remove the waffle using a non-metallic utensil. If another waffle is in the baker, rotate the baking unit so the opposite lid is topmost, open the baker lid, and remove the waffle. If additional baking is planned, close the baker lid to retain heat.

Using the Waffle Baker



14. To prepare more waffles, reset the baking timer by pressing the Reset Button (↺). The display background will return to blue and the timer will revert to the previous time set. Then repeat steps 5–13.

NOTE: Unless the baking timer is reset, the Waffle Baker will automatically shut off 5 minutes after the timer reaches zero.

15. When baking is finished, press the Power (⏻) Button to turn the baking unit off. Leave a baker lid open to speed cooling of the baking unit.

Canceling a Baking Timer Countdown

To cancel a timer countdown, press the Reset Button (↺). The baking timer display will revert to the previous time set. After the timer has been reset, use the Timer Adjustment Dial (⊖) to change the baking time, if desired, and press the Start Button (▶) to begin a new timer countdown. If a timer countdown is not started within 2 hours, the baking unit will automatically shut off.

Recipe Tips

- Do not over-mix the batter. A few lumps are fine. Smooth batters produce tough, heavy waffles.
- If refrigerated in a tightly sealed container, most batters will remain fresh for one or two days. Stored batter will usually thicken, so you may have to add a little water or milk and re-mix the batter before using. Cold batter may require additional baking time to reach desired brownness.
- Recipes that include butter, oil, or eggs will produce crispier, more easily browned waffles than recipes without those ingredients.
- Waffles made from low-fat recipes can be difficult to remove. If your waffles tend to stick to the waffle plates, add a little more butter or oil to the recipe. Do not coat the waffle plates with spray-on oils or shortenings, they will produce a gummy build-up that will be difficult to remove.
- For exceptionally light waffles, try this: when the recipe calls for eggs, separate the eggs and blend the yolk into the batter. In a separate bowl, beat the whites until fluffy – but not stiff – and carefully fold the whites into the batter just before baking.
- For a hearty, full-grain flavor, try using whole grain flour in place of white flour.
- Buttermilk powder is a good substitute for fresh buttermilk in waffle recipes and is easy to keep on hand. Use powder according to package directions.

Baking & Serving Tips

- Whether one or two waffles are being prepared, always rotate the baking unit after filling a waffle plate. This coats both the upper and lower waffle plates with batter and ensures the finest consistency.

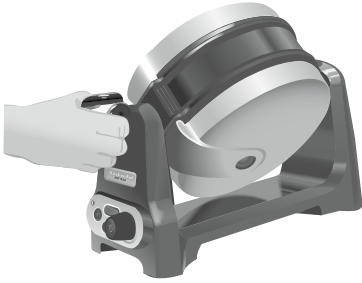

- Don't overfill the waffle plates. Pour the batter onto the center of the plate, then evenly spread it out to the edges using a soft spatula or the bottom of a non-metallic ladle. The batter should almost cover the peaks of the waffle grid.
- Do not coat the waffle plates with spray-on oils or shortenings – they will produce a gummy build-up that will be difficult to remove. If your waffles tend to stick to the plates, add a little more butter or oil to the recipe.
- Use a pitcher instead of a ladle: it's much easier to pour batter than to ladle it.

- Close the baker lid immediately after removing a waffle. This helps maintain the proper baking temperature for additional waffles.
- Waffles will lose their crispiness if stacked or placed on a solid surface. For the best results, keep waffles on a wire rack before serving.
- When preparing multiple waffles for serving, keep the finished waffles warm by placing them in a 90° C oven for up to 15 minutes. Lay the waffles in a single layer directly on the oven rack. Waffles can also be warmed by placing them into a pre-heated Waffle Baker for 1 minute.
- Extra waffles can be frozen with very good results. Cool the leftovers in a single layer on a wire rack, separate the waffles with wax paper, and place them in a plastic freezer bag or other airtight container before putting them into the freezer. When you're ready to enjoy them, lay them in a single layer directly on the oven rack and heat for 10 minutes at 140° C. Frozen waffles can also be heated by placing them into a pre-heated Waffle Baker for 2½ to 3 minutes.

Cleaning the Waffle Baker

1. Make certain the Waffle Baker is switched off, unplugged, and cool before cleaning.

NOTE: Do not immerse the Waffle Baker in water. Do not use abrasive cleansers or scouring pads.

2. Open the baker lids and wipe the waffle plates clean with paper towels or a damp cloth.
3. Wipe the exterior of the Waffle Baker with a warm, sudsy cloth; then wipe the baker clean with a damp cloth and dry with a soft cloth. Do not use abrasive cleansers or scouring pads.

Troubleshooting

The Waffle Baker may emit a slight odor or smoke the first time it is used. This is a normal result of the manufacturing process. The odor or smoke is harmless and will dissipate quickly, but it may flavor the first waffle prepared on each side of the baker. For the best results, it is recommended that these initial waffles be discarded.

Steam will be produced during every baking cycle and condensation may form on the baker lids. This is normal.

- **If the baking timer display remains dark and the Waffle Baker fails to heat:**

⚠ WARNING



Electrical Shock Hazard

Plug into a grounded outlet.

Do not remove ground prong.

Do not use an adapter.

Do not use an extension cord.

Failure to follow these instructions can result in death, fire, or electrical shock.

- Make sure the Waffle Baker is plugged into a grounded outlet. If it is, unplug the Waffle Baker, then plug it back into

the same outlet again. If the baking timer display remains unlit, check the fuse or circuit breaker on the electrical circuit the Waffle Baker is connected to and make certain the circuit is closed.

- **If your waffles are thin or uneven, with gaps and spaces:**
 - Always rotate the baking unit after filling a waffle plate with batter. This coats both the upper and lower waffle plates with batter and ensures the finest consistency.

- **If your waffles are too light or dark:**
 - Increase the baking time if your waffles are too light; decrease the time if your waffles are too dark. The baking time will be affected by many factors, including recipe ingredients, batter temperature, and ambient humidity.

If the problem cannot be fixed with the steps above, see the KitchenAid Warranty and Service section on page 17.*

* Do not return the Waffle Baker to the retailer – they do not provide service.

Banana and Walnut Waffles

600 g plain flour
1 teaspoon sugar
½ teaspoon salt
15 g dry yeast
½ teaspoon ground ginger
120 ml water
355 ml skimmed milk
120 g margarine, cubed
4 eggs
25 g brown sugar
320 g diced bananas
120 g chopped walnuts

In the large mixing bowl, using the flat beater, mix flour, sugar, salt, yeast and ginger on speed 1 for 30 seconds; set aside. In a medium saucepan, place water, milk, and margarine. Heat over low heat until mixture is very warm (47°C to 52°C, not boiling), stirring frequently. Pour the mixture into the large mixing bowl (with the flour/sugar/salt/yeast/ginger), add eggs and mix well on speed 8 for 2 minutes. Cover with a cloth. Let stand at room temperature at least 1 hour until batter is light and fluffy and has doubled in volume.

Add to the mixture, brown sugar, bananas, and walnuts; mix well for another 2 minutes on speed 6.

Set preheated Waffle Baker timer to 3 minutes and 45 seconds.

Pour 4 ladles of batter (30 ml for each ladle) into top side of Waffle Baker. Close top; start timer and rotate baker. Fill second side of baker; rotate baker again. When signal bleeps, remove first waffle. Rotate and remove second waffle. Carry on until no batter is left.

Sprinkle with sugar according to taste.

Serving: for 8 round waffles

Chocolate Chip Waffles

475 g plain flour
200 g mini, semi-sweet
chocolate chips
30 g granulated sugar
8 g baking powder
½ teaspoon salt
1 teaspoon cinnamon,
(optional)
400 ml milk
80 g melted margarine
4 eggs
Chocolate whipped cream
(for serving)

In large mixing bowl, combine flour, granulated sugar, baking powder, salt, and cinnamon (if using). Add milk, margarine, and eggs; using the flat beater, mix on speed 2 for 2 minutes until moistened. Increase the mixer speed to 6 until the batter becomes light and fluffy. Some lumps may remain. Add the chocolate chips and stir carefully using a spatula.

Set preheated Waffle Baker timer to 3 minutes and 45 seconds.

Pour 3 ladles of batter (30 ml for each ladle) into top side of Waffle Baker. Close top; start timer and rotate baker. Fill second side of baker; rotate baker again. When signal beeps remove first waffle. Rotate and remove second waffle. Carry on until no batter is left.

Serve with Chocolate Whipped Cream.

Serving: for 6 round waffles

Brussels Hot Waffles

250 g self-raising flour
250 ml milk
100 g melted margarine
24 g vanilla sugar
3 eggs, separated
1 pinch of salt
Icing sugar (optional, for
serving)

Using the flat beater, mix flour and sugar in a mixing bowl on speed 2 for 15 seconds. Add a little milk and stir well on speed 2 for 30 seconds then add the egg yolks and the rest of the milk. Stir again on speed 2 for 1 minute to obtain a smooth batter.

In another mixing bowl using the wire whisk, whip the egg whites and a pinch of salt on speed 10 for 1 minute.

Add the melted margarine and carefully fold in the whisked egg whites using the flat beater on speed 1 for 45 seconds.

Set preheated Waffle Baker timer to 3 minutes and 30 seconds.

Pour 4 ladles of batter (of 30 ml each) into top side of Waffle Baker. Close top; start timer and rotate baker. Fill second side of baker; rotate baker again. When signal beeps remove first waffle. Rotate and remove second waffle. Carry on until no batter is left.

Serve the waffles warm, sprinkled with icing sugar.

Serving: for 6 round waffles

Chantilly Waffles

- 200 g plain flour
- 250 ml cold milk
- 6 egg yolks
- 200 g melted margarine
- 16 g vanilla sugar
- 4 g baking powder
- 1 pinch of salt
- 12 egg whites whisked firmly (using the wire whisk on speed 10 for 1 minute and 45 seconds)

Sugared whisked cream
(optional, for serving)

Strawberries or raspberries
(optional, for serving)

Using the flat beater, whisk the egg yolks with the cold milk on speed 4 for 1 minute in a mixing bowl. Slowly fold in the flour and the baking powder, then the melted margarine, the vanilla sugar and the salt on speed 4 for 1 minute and 30 seconds. Finally fold in the stiff whisked egg whites on speed 2 for 45 seconds.

Set preheated Waffle Baker timer to 3 minutes and 30 seconds.

Pour 4 ladles of batter (of more or less 40 ml each) into top side of Waffle Baker. Close top; start timer and rotate baker. Fill second side of baker; rotate baker again. When signal bleeps remove first waffle. Rotate and remove second waffle. Carry on until no batter is left.

Leave to cool and cover with sugared whisked cream and fruit (strawberries and/or raspberries).

Serving: for 8 round waffles

Liège Waffles*

- 1 kg plain flour
- 500 ml lukewarm milk
- 60 g fresh yeast
- 6 eggs, separated
- 1 pinch of salt
- 16 g vanilla sugar
- 500 g softened margarine
- 600 g pearled sugar (in big grains)
- 75 g caster sugar

Put flour and yeast in a large mixing bowl. Using the flat beater, mix on speed 2 for 15 seconds. Make a hole in the middle. Add caster sugar and 250 ml lukewarm milk. Stir on speed 2 for 1 minute to obtain a smooth mixture. Leave to stand for 5 minutes. Mix carefully while incorporating the egg yolks on speed 4 for 2 minutes. Add the rest of the lukewarm milk, the softened margarine and the vanilla sugar, and mix on speed 4 for about 3 minutes.

In another mixing bowl using the wire whisk, whip the egg whites and a pinch of salt on speed 10 for 1 minute.

Carefully fold in the whisked egg whites into the batter using the flat beater on speed 1 for 45 seconds.

Leave to stand for about 30 minutes.

Incorporate the pearled sugar carefully into the batter using a spatula.

Shape into equal amounts of batter of 100 g (like a dough). Leave to stand for 15 minutes on a floured cloth.

Set preheated Waffle Baker timer to 4 minutes and 15 seconds.

Put 4 equal amounts of batter into top side of Waffle Baker. Close top ; start timer and rotate baker. Fill second side of baker; rotate baker again. When signal bleeps remove first waffle. Rotate and remove second waffle. Carry on until no batter is left.

Serving: for 10 round waffles

* Not feasible for Great Britain. As "pearled sugar" does not exist in the U.K., this recipe cannot be executed correctly.

Waffles with Cinnamon

500 g plain flour
250 g soft butter
200 g brown sugar
14 g dry yeast
16 g cinnamon
4 eggs
250 ml lukewarm milk
150 ml water

Put 200 g of plain flour, brown sugar, yeast and cinnamon in a large mixing bowl. Using the flat beater, mix on speed 2 for 15 seconds. Make a hole in the middle. Put in soft butter, eggs and some lukewarm milk. Start mixing on speed 2 for 30 seconds, continue on speed 4 for 1 minute while adding the rest of the flour little by little. Turn the mixer to speed 4 for 1 minute and add the rest of the lukewarm milk and water with small amounts at a time. Finally turn mixer to speed 10 for another 30 seconds to obtain a light and fluffy batter.

Leave to stand for about 1 hour at room temperature.

Shape into equal amounts of batter (of +/- 60 g each, like a dough). Leave to stand for a few moments on a floured cloth.

Set preheated Waffle Baker timer to 4 minutes and 15 seconds.

Put 4 equal amounts of batter into top side of Waffle Baker. Close top ; start timer and rotate baker. Fill second side of baker; rotate baker again. When signal bleeps remove first waffle. Rotate and remove second waffle. Carry on until no batter is left.

Serving: for 6 round waffles

4/4 Waffles

250 g plain flour
250 g caster sugar
250 g soft margarine
4 eggs, separated
1 pinch of salt

Vanilla sugar, according to taste

(The taste of lemon can replace the vanilla, in this case, grate a lemon zest and add it to the batter).

Using the wire whisk, whip the egg whites and a pinch of salt in a large mixing bowl on speed 10 for 1 minute until stiff.

Using the flat beater, mix flour and sugar on speed 2 for 15 seconds in another large mixing bowl. Fold in margarine and 4 egg yolks. Stir well on speed 2 for 1 minute. Carefully fold in the whisked egg whites into the batter together with the vanilla sugar or lemon zest using a spatula.

Leave to stand for about 10 minutes in the refrigerator.

Set preheated Waffle Baker timer to 3 minutes and 45 seconds.

Put 4 equal amounts of batter (equivalent 30 ml each) into top side of Waffle Baker. Close top; start timer and rotate baker. Fill second side of baker; rotate baker again. When signal bleeps remove first waffle. Rotate and remove second waffle. Carry on until no batter is left.

Serving: for 4 round waffles

Soft Vanilla Waffles

500 g self raising flour
300 g melted margarine
1 pinch of salt
325 g caster sugar
5 eggs
40 g vanilla sugar
240 ml (1 cup) of water

Using the wire whisk, whip the 5 eggs as for an omelette in a large mixing bowl on speed 2 for 1 minute.

Add the melted margarine and a pinch of salt. Fold in 325 g caster sugar and using the flat beater, mix on speed 1 for 1 minute, then fold in vanilla sugar and cup of water. Turn mixer speed to 6 and stir for another minute. Add the flour little by little and stir well on speed 8 until batter is smooth without any lumps left.

Leave to stand for about 10 minutes in the refrigerator.

Set preheated Waffle Baker timer to 3 minutes and 45 seconds.

Pour 4 ladles of batter (of about 30 ml each) into top side of Waffle Baker. Close top ; start timer and rotate baker. Fill second side of baker; rotate baker again. When signal beeps remove first waffle. Rotate and remove second waffle. Carry on until no batter is left.

Serving: for 7 round waffles

Waffles with Almonds

500 g self-raising flour
300 g caster sugar
300 g melted margarine
100 g ground almonds
4 eggs (small)
100 ml water
1 pinch of salt

Using the wire whisk, whip the 4 eggs in a large mixing bowl on speed 2 for 45 seconds.

Put the flour in another mixing bowl. Add salt, sugar and almonds. Using the flat beater, mix on speed 2 for 15 seconds. Make a hole in the middle. Put in the whisked eggs and the flour little by little on speed 2 for 2 minutes. Add melted margarine and water. Continue mixing on speed 2 for another 2 minutes and increase speed to 6 until batter is smooth.

Put aside for 5 minutes in the refrigerator.

Set preheated Waffle Baker timer to 3 minutes and 30 seconds.

Pour 4 large table spoonfuls of batter (of about 30 ml each) into top side of Waffle Baker. Close top ; start timer and rotate baker. Fill second side of baker; rotate baker again. When signal beeps remove first waffle. Rotate and remove second waffle. Carry on until no batter is left.

Serving: for 6 round waffles

Delicious Waffles with Beer

250 g plain flour
175 g caster sugar
3 eggs
15 g dry yeast
250 ml dark beer
1 pinch of salt
125 g melted margarine

Place all the ingredients (except for the margarine) in a large mixing bowl and stir strongly using the wire whisk on speed 6 for 2 minutes until the batter is smooth. Leave to rest for 30 minutes and add 125 g melted margarine just before cooking. Replace the wire whisk by the flat beater and mix on speed 1 for more or less another 30 seconds.

Set preheated Waffle Baker timer to 3 minutes and 45 seconds.

Pour 4 large tablespoons of batter (of about 30 ml each) into top side of Waffle Baker to obtain delicious thick waffles. Close top; start timer and rotate baker. Fill second side of baker; rotate baker again. When signal bleeps remove first waffle. Rotate and remove second waffle. Carry on until no batter is left.

Serving: for 5 round waffles

Belgian Waffles

250 g plain flour
300 ml milk
200 ml double cream
70 g caster sugar
1 tablespoon of dry yeast
4 eggs, separated
150 g butter, melted and cooled
1 pinch of salt

Maple syrup (optional,
for serving)

Icing sugar (optional,
for serving)

Warm the milk and cream to just below boiling point; set aside. Put flour, 50 g of the caster sugar and the yeast in the mixing bowl. Using the flat beater, mix on speed 1 for 30 seconds. Stir in the egg yolks and mix on speed 2 for 2 minutes. Add the milk, cream and melted butter. Replace the beater by the wire whisk and mix on speed 6 until batter is thick and smooth. Cover and leave to stand at room temperature for 1 hour.

In another bowl, using the wire whisk, whip the egg whites and a pinch of salt on speed 8 for 30 seconds until egg whites are stiff. Add remaining sugar and whisk again until peaking.

Fold the egg whites into the batter with a spatula.

Set preheated Waffle Baker timer to 3 minutes and 45 seconds.

Pour enough batter into top side of Waffle Baker to obtain delicious waffles. Close top; start timer and rotate baker. Fill second side of baker; rotate baker again. When signal bleeps remove first waffle. Rotate and remove second waffle. The waffle is cooked when golden brown and crisp and it can be easily removed from the Waffle Baker. Carry on until no batter is left.

Serve the waffles hot with maple syrup or icing sugar.

Serving: for 8 round waffles

KitchenAid® Artisan® Waffle Baker Warranty

Length of Warranty:	KitchenAid Will Pay For:	KitchenAid Will Not Pay For:
<p>Europe & Australia: Two Year Full Warranty from date of purchase.</p> <p>Other: One Year Full Warranty from date of purchase.</p>	Replacement parts and repair labor costs to correct defects in materials or workmanship. Service must be provided by an Authorized KitchenAid Service Center.	<p>A. Repairs when Waffle Baker is used for operations other than normal food preparation.</p> <p>B. Damage resulting from accident, alterations, misuse, abuse, or installation/operation not in accordance with local electrical codes.</p>

KITCHENAID DOES NOT ASSUME ANY RESPONSIBILITY FOR INDIRECT DAMAGES.

Service Centers

All service should be handled locally by an Authorized KitchenAid Service Center. Contact the dealer from whom the unit was purchased to obtain the name of the nearest Authorized KitchenAid Service Center.

In the U.K.:
Call: 0845 6011 287

In Ireland:
M.X. ELECTRIC
Service Department
25 Alymer Crescent
Kilcock, CO.KILDARE
Call: 1 679 2398/87 2581574
Fax: 1 628 4368

In Australia:
Call: 1800 990 990

In New Zealand:
Call: 0800 881 200

Customer Service

For U.K. & Northern Ireland:

Freephone helpline number on:
0800 988 1266
(calls from mobiles are charged
at your standard network rate)

For Southern Ireland:

Helpline number on:
+44 (0) 20 8616 5148

Address:

KitchenAid Europa, Inc.
PO BOX 19
B-2018 ANTWERP 11
BELGIUM

www.KitchenAid.co.uk

www.KitchenAid.com



FOR THE WAY IT'S MADE.®

® Registered Trademark of KitchenAid, U.S.A.

™ Trademark of KitchenAid, U.S.A.

© 2008. All rights reserved.

Specifications subject to change without notice.

(6087AdZw608)