

This Owner's Manual is provided and hosted by [Appliance Factory Parts](#).



KITCHENAID KCM514WH1 Owner's Manual

[Shop genuine replacement parts for KITCHENAID
KCM514WH1](#)

WATER TANK, CARAFE, AND FILTER PARTS
For Models: KCM514WH0, KCM514OB0, KCM514ER0, KCM514BU0 14 CUP COFFEE MAKER
KitchenAid, (White) (Onyx Black) (Empire Red) (Cobalt Blue)

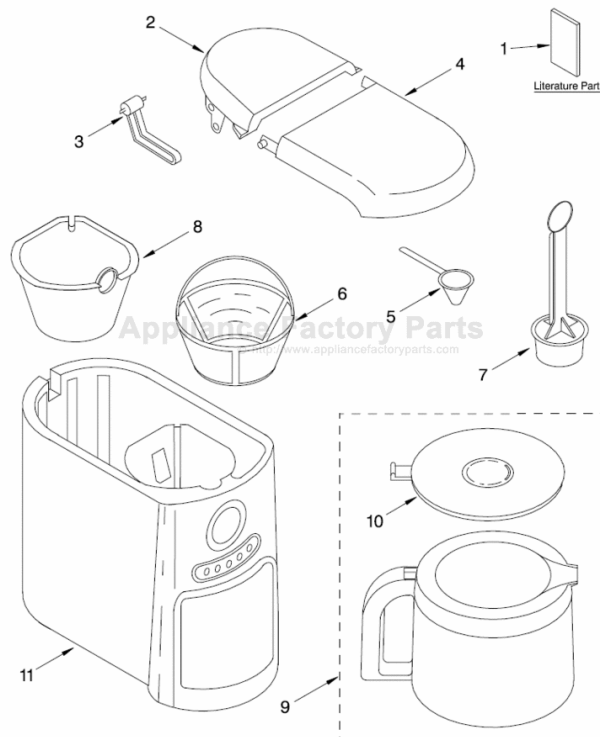

[Find Your KITCHENAID Small Appliance Parts - Select From 538 Models](#)

----- Manual continues below -----

KitchenAid®

JAVASTUDIO™ COLLECTION PROGRAMMABLE COFFEE MAKERS

INSTRUCTIONS

KCM511
KCM514
KCM515



1-800-541-6390
Details Inside



FOR THE WAY IT'S MADE.™

Hassle-Free Replacement Warranty



We're so confident the quality of our products meets the exacting standards of KitchenAid that, if your Coffee Maker should fail

within the first year of ownership, KitchenAid will arrange to deliver an identical or comparable replacement to your door free of charge and arrange to have your original Coffee Maker returned to us. Your replacement unit will also be covered by our one year full warranty. Please follow these instructions to receive this quality service.

If You Reside In The 50 United States and your KitchenAid® Coffee Maker should fail within the first year of ownership, simply call our toll-free Customer Satisfaction Center at **1-800-541-6390** Monday through Friday, 8 a.m. to 8 p.m. (Eastern Time), or Saturday, 10 a.m. to 5 p.m. Give the consultant your complete shipping address. (No P.O. Box Numbers, please.)

When you receive your replacement Coffee Maker, use the carton and packing materials to pack-up your original Coffee Maker. In the carton, include your name and address on a sheet of paper along with a copy of the proof of purchase (register receipt, credit card charge slip, etc.).

For a detailed explanation of warranty terms and conditions, including how to arrange for service outside the United States, see pages 17 and 18.

Proof of Purchase & Product Registration

Always keep a copy of the sales receipt showing the date of purchase of your Coffee Maker. Proof of purchase will assure you of in-warranty service.

Before you use your Coffee Maker, please fill out and mail your product registration card packed with the unit. This card will enable us to contact you in the unlikely event of

a product safety notification and assist us in complying with the provisions of the Consumer Product Safety Act. This card does not verify your warranty.

Please complete the following for your personal records:

Model Number _____

Serial Number _____

Date Purchased _____

Store Name _____

Table of Contents

INTRODUCTION

Hassle-Free Replacement Warranty.....	Inside Front Cover
Product Registration Card	Inside Front Cover
Coffee Maker Safety	2
Electrical Requirements	2
Important Safeguards.....	3

FEATURES AND OPERATION

Coffee Maker General Features	4
Display and Control Pad Features.....	6
Pre-Use Cleaning	8
Installing the Water Filter.....	8
To Set the Time-of-Day Clock.....	9
Brewing Coffee.....	10
Using the Thermal Carafe	11
The Pause and Pour Feature.....	12
Using the Automatic Brew Timer	12
The Cleaning Needed Indicator.....	13
Coffee Brewing Suggestions: Advice for Great Taste	14

CARE AND CLEANING

Cleaning the Coffee Maker	15
Descaling the Coffee Maker.....	15
Troubleshooting and Error Codes.....	16

WARRANTY AND SERVICE INFORMATION

Warranty for the 50 United States and District of Columbia	17
Warranty For Puerto Rico.....	18
Arranging for Service after the Warranty Expires.....	18
Arranging for Service Outside the 50 United States and Puerto Rico.....	18
Ordering Accessories and Replacement Parts	18

Coffee Maker Safety

Your safety and the safety of others are very important.

We have provided many important safety messages in this manual and on your appliance. Always read and obey all safety messages.



This is the safety alert symbol.

This symbol alerts you to potential hazards that can kill or hurt you and others.

All safety messages will follow the safety alert symbol and either the word "DANGER" or "WARNING." These words mean:

⚠ DANGER

You can be killed or seriously injured if you don't immediately follow instructions.

⚠ WARNING

You can be killed or seriously injured if you don't follow instructions.

All safety messages will tell you what the potential hazard is, tell you how to reduce the chance of injury, and tell you what can happen if the instructions are not followed.

Electrical Requirements

Volts: 120 V.A.C. only. Hertz: 60 Hz

⚠ WARNING



Electrical Shock Hazard

Plug into a grounded 3 prong outlet.

Do not remove ground prong.

Do not use an adapter.

Do not use an extension cord.

Failure to follow these instructions can result in death, fire or electrical shock.

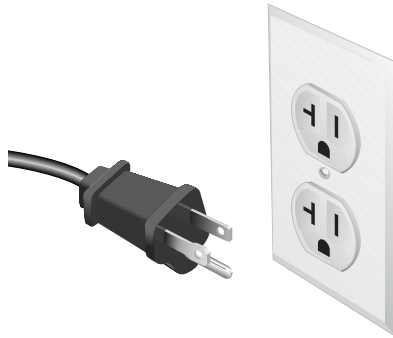

NOTE: Your Coffee Maker has a 3 prong grounded plug. To reduce the risk of electrical shock, this plug will fit in an outlet only one way. If the plug does not fit in the outlet, contact a qualified electrician. Do not modify the plug in any way.

Do not use an extension cord. If the power supply cord is too short, have a qualified electrician or serviceman install an outlet near the appliance.

IMPORTANT SAFEGUARDS

When using electrical appliances, basic safety precautions should always be followed, including the following:

1. Read all instructions.
2. Do not touch hot surfaces. Use handles or knobs.
3. To protect against electrical shock, do not immerse cord, plugs, or Coffee Maker in water or other liquid.
4. Close supervision is necessary when any appliance is used by or near children.
5. Unplug Coffee Maker from outlet before cleaning. Allow to cool before putting on or taking off parts, and before cleaning the appliance.
6. Do not operate any appliance with a damaged cord or plug, or after the appliance malfunctions or has been damaged in any manner. Return appliance to the nearest Authorized Service Facility for examination, repair, or adjustment.
7. The use of accessories not recommended by the appliance manufacturer may result in fire, shock or injury to persons.
8. Do not use outdoors.
9. Do not let cord hang over edge of table or counter, or touch hot surfaces.
10. Do not place on or near a hot gas or electric burner, or in a heated oven.
11. Do not use appliance for other than its intended use.
12. Do not use appliance without lid properly placed on container.
13. The container is designed for use with this appliance. It must never be used on a range top.
14. Do not set a hot container on a wet or cold surface.
15. Do not use a cracked container or a container having a loose or weakened handle.
16. Do not clean container with cleaners, steel wool pads, or other abrasive material.
17. This product has been UL Listed for household use.

SAVE THESE INSTRUCTIONS

General Features



General Features

JavaSpa™ Showerhead

Extra-wide showerhead sprays the brew basket evenly with hot water, ensuring even coffee extraction and outstanding flavor.

1100-Watt Heat Pump

(not shown)

Powerful heat pump brews rich, flavorful coffee.

Electronic Temperature Control

Fully electronic control directly monitors the temperature of the heat pump to brew - and keep - coffee at optimal temperatures.

Pause & Pour Feature

Pause and pour lets you remove the carafe and pour a cup of coffee before brewing is finished. A special valve seals the brew basket tightly, eliminating drips.

End-Of-Brewing Tone

A tone sounds when coffee is finished brewing.

Automatic Shutoff

Coffee Maker automatically shuts off two hours after brewing.

Split-Lid

Access the brew basket and water reservoir by lifting the split-lid. The front lid covers the brew basket and reservoir fill-channel. The rear lid covers the water reservoir and water filter.

Brew Basket

Lift the front lid to access the removable, dishwasher-safe brew basket. The basket holds a 10-12 cup flat-bottom paper coffee filter or the gold tone permanent filter.

Reservoir Fill-Channel

The Coffee Maker features a convenient front-fill water reservoir. Just lift the front lid and use the convenient fill-channel to add water. You can also lift the rear lid and add water directly to the reservoir.

Brew Timer Display

Shows the AM or PM time-of-day. An easy-to-set 24 hour brew timer will brew coffee at the selected time, day or night.

“Time Since Brew” Display

30, 60, 90, and 120-minute segments light up to indicate the time elapsed since the last carafe was brewed.

Clean Touch™ Control Pad

The control pad makes operating the Coffee Maker simple. The pad is sealed against spills, will not trap grime, and is a snap to wipe clean.

Glass Carafe

(models KCM511, KCM514)

Dishwasher-safe glass carafe features a no-drip pouring spout and comfortable handle.

Stainless Steel Thermal Carafe

(model KCM515 – not shown)

Thermal carafe preserves flavor by keeping coffee warm without continuous heating. Stainless steel construction with vacuum insulation will keep coffee piping hot for hours.

Gold Tone Permanent Filter

The high-performance gold tone filter eliminates the need for paper coffee filters. Coffee Maker can also use paper filters, if desired.

continued...

General Features

Ion-Exchange Water Filter / Water Level Indicator (not shown)

Advanced filter reduces chlorine and other contaminants which impair coffee flavor. Filter also softens the water, which increases the time between descalings. The filter handle serves as a convenient water level indicator.

Full-Length Cord Storage (not shown)

Compartment in back of unit keeps excess cord out of the way.

Wrap-Around Housing

Stylish design minimizes heat loss from the carafe while protecting it from accidental spills and breakage.

Coffee Scoop

Use one rounded scoop of ground coffee for each cup desired.

Display and Control Pad Features



Display and Control Pad Features

DISPLAY FEATURES:

Brew Timer Display

Shows the time-of-day. Small lights indicate whether the time is AM or PM. An easy-to-set 24-hour brew timer will brew coffee at the selected time, day or night.

"Time Since Brew" Display

Display shows the time elapsed since the completion of the brewing cycle. The "30" segment will light immediately after brewing, indicating the coffee is less than 30 minutes old. Every 30 minutes, a new segment will light.

Cleaning Needed Indicator

The indicator will light after brewing if the Coffee Maker requires descaling.

"H" and "M" Buttons

Use the "H" (hour) and "M" (minute) buttons to program the brew timer or set the time-of-day clock.

CONTROL PAD FEATURES:

On/Off

Press to turn the Coffee Maker on or off. An indicator light shows when the Coffee Maker is on.

1-4 Cup

After turning on the Coffee Maker or activating the automatic brew timer, press the 1-4 Cup Button to turn the 1 to 4 cup brew cycle on or off. This special cycle heats small quantities of water thoroughly, ensuring optimum flavor when brewing small pots of coffee. An indicator light shows when the 1 to 4 cup brew cycle is activated.

Auto On

Press to turn the automatic brew timer on or off. When the brew timer is turned on, the ...

- Programmed brew time will briefly appear on the brew timer display
- Auto On indicator will light
- Coffee Maker will begin brewing at the programmed time

If a programmed brew time has not been set when the Auto On Button is pressed, the Coffee Maker will automatically enter the Set (Program) mode.

Set (Program)

Press to program an automatic brew time. When the Set (Program) Button is pressed, the ...

- Brew timer display will flash
- Set (Program) indicator will flash
- "H" (hour) and "M" (minute) Buttons can be used to set a brew time

Set (Clock)

Press to set the time-of-day clock. When the Set (Clock) Button is pressed, the ...

- Brew timer display will flash
- Set (Clock) indicator will flash
- "H" (hour) and "M" (minute) Buttons can be used to set the clock

Preparing Your Coffee Maker for Use

Pre-Use Cleaning

Wash the brew basket, gold tone permanent filter, and carafe in hot, soapy water, then rinse with clean water and dry. Do not use abrasive cleansers or scouring pads.

Installing the Ion-Exchange Water Filter

Use of the ion-exchange water filter is strongly recommended. The filter softens the water while reducing chlorine and other contaminants which impair coffee flavor. The handle of the filter also serves as a water level indicator. Use of the water filter is optional: the Coffee Maker will operate normally without it.

The water filter is for use only with municipally treated tap water or well water that is regularly tested for contaminants.

1. Remove the filter from its packaging. The filter consists of a long handle with a filter cartridge at the end.
2. Place the filter cartridge in a separate container filled with fresh, cool water. The cartridge should remain submerged in the water for 10 minutes.
3. Lift the rear portion of the split-lid using the tabs on either side of the lid.

4. Place the filter cartridge in the circular well at the bottom of the water reservoir, aligning the tab on the cartridge with the notch in the well. The water level markings on the filter handle will face forward. Push the cartridge slightly to make sure it fits snugly.

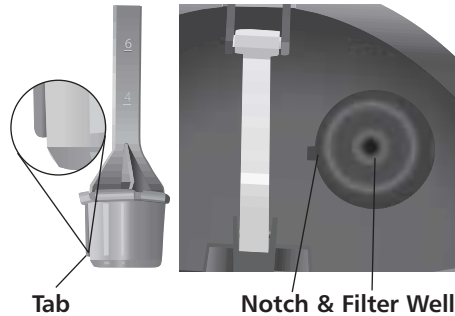

5. Every time you install a new filter, run the Coffee Maker through a complete brewing cycle without coffee. Use a full carafe of clean, cool water.
6. Replace the filter every three months under normal use. Replace it more often under heavy use or hard-water conditions.

Preparing Your Coffee Maker for Use

To Set the Time-of-Day Clock

⚠ WARNING



Electrical Shock Hazard

Plug into a grounded 3 prong outlet.

Do not remove ground prong.

Do not use an adapter.

Do not use an extension cord.

Failure to follow these instructions can result in death, fire or electrical shock.

1. Plug power cord into a grounded 3 prong outlet.
2. When the Coffee Maker is first plugged in or when power is restored after an interruption, the brew timer display will initially show 12:00 am.
3. Press the Set (Clock) Button. The brew timer display and Set (Clock) indicator will begin to flash.



4. Press the "H" (hour) and "M" (minute) Buttons below the brew timer display to set the hour and minutes. If a "H" or "M" Button is pressed and held, the digits will scroll rapidly. The AM and PM indicator lights on the brew timer display will change when the hour digits roll past "12". Make sure the hour set is correct with respect to AM or PM.

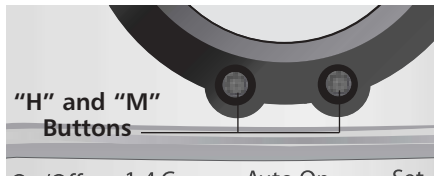

5. Press the Set (Clock) Button to exit the clock-setting mode. The digits on the brew timer display will stop flashing and the Set (Clock) indicator will go out. The Coffee Maker will automatically record the displayed time and exit clock-setting mode if no buttons are pressed for 10 seconds.

Operating Your Coffee Maker

Brewing Coffee

1. Fill a carafe with enough fresh, cool water to make the desired amount of coffee. A graduated scale on the side of the glass carafe helps measure the amount of water required. The right side of the scale ("coffee") is a measurement of carafe volume in 4¼ ounce cups. The left side of the scale ("water") indicates the amount of water needed to produce a given number of cups. For thermal carafe model KCM515, the scale on the water filter handle can be used to gauge the amount of water to add.



2. Lift the front lid and fill the water reservoir with fresh cool water using the reservoir fill-channel to the right of the brew basket. Water can also be poured directly into the reservoir at the back of the Coffee Maker.



3. After filling the reservoir, place the carafe on the Coffee Maker warming plate. Make sure the bottom of the carafe is fully seated

on the plate – if the carafe isn't seated, the pause and pour feature may engage and coffee may overflow the brew basket.

4. Remove the brew basket from the top of the Coffee Maker by grasping the finger loop on the front of the basket.



5. Insert a 10-12 cup flat-bottom paper filter or the gold tone permanent filter into the brew basket. Never use both types of filter at the same time – using both may cause water to overflow the brew basket.
6. Using the included scoop, fill the filter with one rounded scoop of ground coffee for each cup desired. Use a medium grind appropriate for automatic drip coffee makers: too fine a grind will produce bitterness and may clog the coffee filter.



NOTE: Always place the filter and coffee into the removable brew basket. Do not operate the Coffee Maker without the brew basket in place.

Operating Your Coffee Maker

7. Shake the brew basket slightly to even out the bed of coffee. This will help ensure uniform coffee extraction and excellent flavor. Place the basket into the Coffee Maker, push it down to seat it securely, and close the lid.
8. Press the On/Off Button to begin brewing coffee. If you are only brewing 1 to 4 cups of coffee, press the 1-4 Cup Button immediately after pressing the On/Off Button. The 1 to 4 cup brew cycle heats small quantities of water thoroughly, ensuring optimum flavor with small pots of coffee.
11. At the end of 2 hours, the Coffee Maker and warming plate will automatically shut off. To turn off the Coffee Maker manually, press the On/Off button. Although the thermal carafe model KCM515 does not have a warming plate, the outside of the carafe may be warm to the touch after brewing.
12. Repeat steps 1-8 to brew additional carafes of coffee. Always turn off the Coffee Maker and allow it to cool for five minutes before starting the next brew cycle.



- NOTE:** Lifting the front lid while coffee is brewing will interrupt the brew process and impair flavor.
9. The Coffee Maker will sound the end-of-brewing tone when brewing is complete.
 10. The "Time Since Brew" display indicates the time elapsed since the completion of the brewing cycle. The "30" segment will light immediately after brewing, indicating the coffee is less than 30 minutes old. Every 30 minutes, a new segment will light.



Using the Thermal Carafe (model KCM515 only)

The stainless steel thermal carafe features a double walled, vacuum insulated design that will keep coffee hot – and flavorful – for hours. The special lid and spout design doesn't require you to turn a stopper or press a button to dispense coffee – just tilt the carafe and pour! When you set the carafe upright, the lid will seal automatically.

- To remove the carafe lid for cleaning, turn it counter-clockwise and lift. The thermal carafe should be hand-washed only – it is not dishwasher-safe.
- To maximize coffee temperature, preheat the carafe before brewing by removing the lid and rinsing the interior with hot tap water.

Operating Your Coffee Maker

The Pause and Pour Feature

The pause and pour feature enables you to remove the carafe from the Coffee Maker and pour a cup of coffee before brewing is finished. When the carafe is removed, a special valve stops the flow of coffee from the brew basket. Brewing, however, does not stop. If the carafe is not placed back on the hot plate within 25 seconds, water will overflow the brew basket and spill onto the warming plate.

Pause and pour is a great convenience for those in a hurry. However, the flavors extracted from ground coffee differ at each stage of the brewing cycle, and a finished carafe represents a delicate blend of these flavors. Using pause and pour will alter – and usually impair – the flavor of the remaining coffee.

Using the Automatic Brew Timer

The Coffee Maker can be programmed to brew coffee at a preset time, making it easy to wake up to fresh coffee every morning. To program and activate the automatic brew timer:

1. Press the Set (Program) Button. The brew timer display and Set (Program) indicator will begin to flash. The brew timer display will show the last brew time set.



2. Press the "H" (hour) and "M" (minute) Buttons below the brew timer display to set the hour and minutes. If a "H" or "M" Button is pressed and held, the digits will scroll rapidly. The AM and PM indicator lights on the brew timer display will change when the hour digits roll past "12". Make sure the desired brew time is correct with respect to AM or PM.



3. After setting the brew time, press the Set (Program) Button to exit the program-setting mode. The digits on the brew timer display will stop flashing and the Set (Program) indicator will go out. The Coffee Maker will automatically record the displayed brew time and exit the program-setting mode if no buttons are pressed for 10 seconds.
4. Fill the Coffee Maker with coffee and fresh water, then activate the automatic brew timer by pressing the Auto On Button. The programmed brew time will appear briefly on the brew timer display before it returns to the time-of-day, and the Auto On indicator will illuminate.



Operating Your Coffee Maker

5. The Coffee Maker will begin brewing at the programmed time.
6. Each time you want the Coffee Maker to brew at the programmed time, activate the automatic brew timer by pressing the Auto On Button. The Coffee Maker will always default to the last brew time set.

NOTE: To cancel automatic brewing, deactivate the brew timer by pressing the Auto On Button. When deactivated, the Auto On indicator light will go out.

The Cleaning Needed Indicator

Calcium deposits (“scale”) from water will build up in the Coffee Maker heat pump over time and impair brewing efficiency and coffee quality. When the Coffee Maker detects a build-up of scale, the cleaning needed indicator will light after a brewing cycle is complete. Once this occurs, descaling should be done as soon as possible to preserve the performance and life of your Coffee Maker. Please see page 15 for descaling steps.



Coffee Brewing Suggestions: Advice for Great Taste

Fresh Coffee Beans

Truly great coffee can only come from fresh coffee beans. To preserve the freshness of your coffee beans, keep the beans in an opaque, air-tight container and store them in a cool, dry place. Refrigeration is not recommended, as condensation tends to form on the beans whenever the container is opened. Freezing can help preserve beans stored for an extended period, but it will also impair the flavor.

The Right Grind

Freshly ground coffee loses flavor and aroma quickly – within minutes. The best cup of coffee will always come from coffee beans that are ground just before brewing.

A proper grind is critical for good coffee, and that means using a quality grinder like the KitchenAid® Blade Coffee Grinder, PRO LINE™ Series Burr Coffee Mill, or the KitchenAid® Model A-9™ Coffee Mill. Be sure to grind your coffee to the correct size – use a medium grind level appropriate for automatic drip coffee makers.

The Proper Amount of Ground Coffee

For standard drip-process coffee, a good starting point is to use one rounded scoop of coffee for every cup of brew water as measured with the carafe. This results in about one ounce of coffee being used for every 16 ounces of brew water – the accepted brewing standard. Finer grinds usually require less coffee, but using too fine a grind will produce bitterness. Very fine grinds may also clog the coffee filter and cause water to overflow the brew basket.

If you prefer substantially weaker-than-average coffee, it's best to brew using a normal amount of ground coffee and then dilute the result with hot water. Doing this will maximize flavor and minimize bitterness.

Brew Water Purity

The ion-exchange water filter that comes with your Coffee Maker reduces off-tastes and contaminants in your brew water. It also softens the water, which enhances coffee flavor. For great tasting coffee, be sure to use the filter – and replace it promptly every three months.

Where local water quality is extremely poor, you may wish to use bottled, purified water with your Coffee Maker. Do not use distilled water or mineral water – they can damage the Coffee Maker.

Coffee Maker Cleanliness

Coffee oils build up quickly within the brew basket and carafe. Over time, these oils will go stale and impair the flavor of freshly brewed coffee. Daily cleaning of the brew basket and carafe is strongly recommended for the best-tasting coffee.

Care and Cleaning

Cleaning the Coffee Maker

1. Unplug the Coffee Maker and allow it to cool before cleaning.
2. Remove the brew basket and carafe from the Coffee Maker.
3. On model KCM515, remove the lid on the thermal carafe by turning it counter-clockwise, then lifting.
4. Wash the brew basket, carafe, and gold tone permanent filter in hot, soapy water and rinse with hot water. Do not use abrasive cleansers or scouring pads. These parts can also be washed in the upper rack of a dishwasher (the thermal carafe included with model KCM515 should be hand-washed only).
5. Wipe the Coffee Maker housing with a warm, soapy cloth. Then wipe clean with a damp cloth and dry with a soft cloth. Do not use abrasive cleansers or scouring pads.

Descaling the Coffee Maker

Calcium deposits ("scale") from water will build up in the Coffee Maker heat pump over time and impair brewing efficiency and coffee quality. When the Coffee Maker detects a build up of scale, the cleaning needed indicator will light after a brewing cycle is complete. Once this occurs, descaling should be done as soon as possible to preserve the performance and life of your Coffee Maker.

The Coffee Maker can be descaled using a packaged descaling agent or vinegar. Always mix the descaling solution using cool water.

- When using a descaling agent, follow the directions on the package for the recommended amounts of descaling agent and water to use.
- When using vinegar, fill the carafe with a solution consisting of $\frac{1}{2}$ vinegar and $\frac{1}{2}$ water.

Descaling Steps:

1. Before descaling, always remove the water filter (see "Installing the Water Filter" on page 8) and make sure the brew basket contains no coffee or coffee filters.
2. Run the Coffee Maker through a complete brewing cycle using a full carafe of the descaling solution.
3. If the cleaning needed indicator lights after the brewing cycle is complete, repeat Step 2 using fresh descaling solution. Keep repeating Step 2 until the cleaning needed indicator no longer lights after brewing.
4. Rinse the Coffee Maker by running it through two brewing cycles using a full carafe of fresh, cool water each time.
5. Wash the brew basket and carafe in hot, soapy water and rinse with hot water. These parts can also be washed in the upper rack of the dishwasher (the thermal carafe included with model KCM515 should be hand-washed only).
6. Reinstall or replace the water filter. Replace the filter every three months under normal usage, or more often with heavy use.

Troubleshooting and Error Codes

- **If the brew timer display is not illuminated:**

Check to see if the Coffee Maker is plugged into a grounded 3 prong outlet. If it is, unplug the Coffee Maker, then plug it into the same outlet again. If the unit still does not work, check the fuse or circuit breaker on the electrical circuit the Coffee Maker is connected to and make sure the circuit is closed.

- **If only a portion of the water added to the Coffee Maker actually brews:**

The Coffee Maker requires immediate descaling. Please refer to the descaling instructions on the previous page.

- **If "Err4" appears on the brew timer display:**

A button is jammed. Unplug the Coffee Maker, press each button several times, then plug the Coffee Maker back in. (If the Coffee Maker has been stored or used in a cool environment, warm the unit to normal room temperature before doing this.) If "Err4" appears again on the display, repeat this procedure.

- **If "Err1", "Err2", or "Err3" appear on the brew timer display:**

Press the On/Off Button to reset the Coffee Maker. If the error codes reappear, there is a problem with the Coffee Maker electronics. Please refer to the Warranty and Service section beginning on the following page.

If the problem cannot be fixed with the steps above, please refer to the Warranty and Service section beginning on the following page.

KitchenAid® Coffee Maker Warranty for the 50 United States and District of Columbia

This warranty extends to the purchaser and any succeeding owner for Coffee Makers operated in the 50 United States and District of Columbia.

Length of Warranty:	KitchenAid Will Pay For Your Choice of:	KitchenAid Will Not Pay For:
<p>One Year Full Warranty from date of purchase.</p>	 <p>Hassle-Free Replacement of your Coffee Maker. See inside front cover for details on how to arrange for service, or call the Customer Satisfaction Center toll-free at 1-800-541-6390.</p> <p>OR</p> <p>The replacement parts and repair labor costs to correct defects in materials and workmanship. Service must be provided by an Authorized KitchenAid Service Center. To arrange for service, follow the instructions under the KitchenAid® Coffee Maker Warranty for Puerto Rico on page 18.</p>	<p>A. Repairs when Coffee Maker is used in other than normal single family home use.</p> <p>B. Damage resulting from accident, alteration, misuse or abuse.</p> <p>C. Any shipping or handling costs to deliver your Coffee Maker to an Authorized Service Center.</p> <p>D. Replacement parts or repair labor costs for Coffee Makers operated outside the 50 United States and District of Columbia.</p>

KITCHENAID DOES NOT ASSUME ANY RESPONSIBILITY FOR INCIDENTAL OR CONSEQUENTIAL DAMAGES. Some states do not allow the exclusion or limitation of incidental or consequential damages, so this exclusion may not apply to you. This warranty gives you specific legal rights and you may also have other rights which vary from state to state.

KitchenAid® Coffee Maker Warranty for Puerto Rico

A limited one year warranty extends to the purchaser and any succeeding owner for Coffee Makers operated in Puerto Rico. During the warranty period, all service must be handled by an Authorized KitchenAid Service Center. Please bring the Coffee Maker, or ship it prepaid and insured, to the

nearest Authorized Service Center. Call toll-free **1-800-541-6390**, 8 a.m. to 8 p.m., Monday through Friday, 10 a.m. to 5 p.m., Saturday, Eastern Time to learn the location of a Service Center near you. Your repaired Coffee Maker will be returned to you prepaid and insured.

Arranging for Service After the Warranty Expires

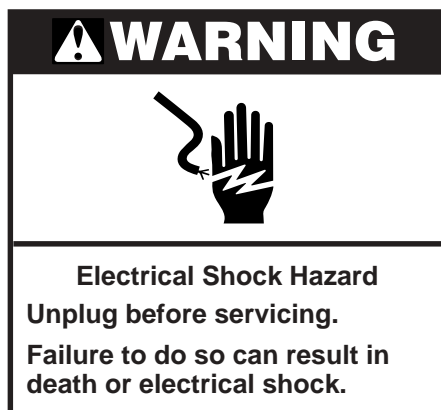

For service information, call toll-free **1-800-541-6390**, 8 a.m. to 8 p.m., Monday through Friday, 10 a.m. to 5 p.m., Saturday, (Eastern Time) or write to:

Customer Satisfaction Center
KitchenAid Portable Appliances
P.O. Box 218
St. Joseph, MI 49085-0218

Arranging for Service Outside the 50 United States and Puerto Rico

Consult your local KitchenAid dealer or the store where you purchased the

Coffee Maker for information on how to obtain service.

Ordering Accessories and Replacement Parts

To order accessories or replacement parts for your Coffee Maker, visit **KitchenAid.com** or call toll-free **1-800-541-6390**, 8 a.m. to 8 p.m., Monday through Friday, 10 a.m. to 5 p.m. on Saturday (Eastern Time).

You can also write to:
Customer Satisfaction Center
KitchenAid Portable Appliances
P.O. Box 218
St. Joseph, MI 49085-0218



FOR THE WAY IT'S MADE.™

® Registered Trademark/™ Trademark of KitchenAid, U.S.A.