

This Owner's Manual is provided and hosted by [Appliance Factory Parts](#).



# KITCHENAID 4KFC3100ER2 Owner's Manual

[Shop genuine replacement parts for KITCHENAID  
4KFC3100ER2](#)

## MOTOR AND HOUSING PARTS

For Models: KFC3100\_2, 4KFC3100\_2

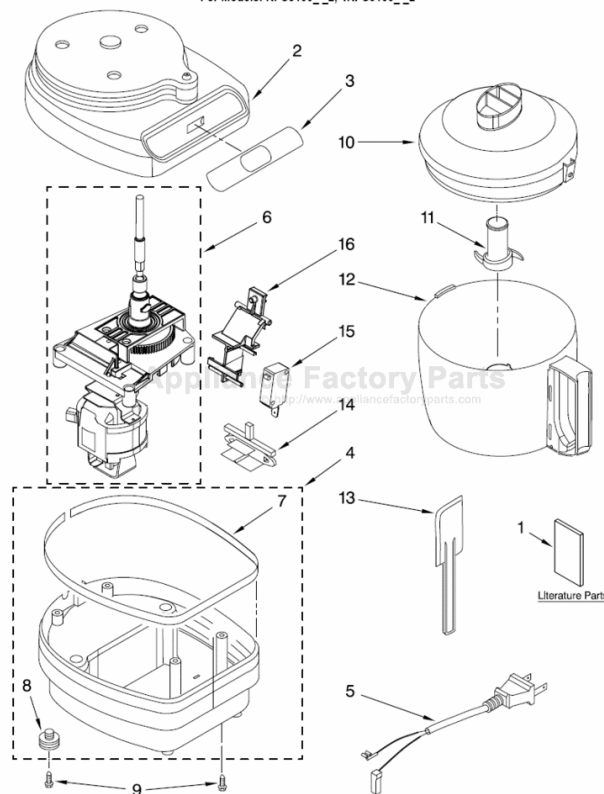

[Find Your KITCHENAID Small Appliance Parts - Select From 538 Models](#)

----- Manual continues below -----

# KitchenAid®

## CHEF'S CHOPPER® SERIES INSTRUCTIONS AND RECIPES



1-800-541-6390  
Details Inside



FOR THE WAY IT'S MADE.™

# Hassle-Free Replacement Warranty

---



We're so confident the quality of our products meets the exacting standards of KitchenAid that, if your Food Chopper should fail

within the first year of ownership, KitchenAid will arrange to deliver an identical or comparable replacement to your door free of charge and arrange to have your "failed" Food Chopper returned to us. Your replacement unit will also be covered by our one year full warranty. Please follow these instructions to receive this quality service.

**If you reside in the 50 United States** and your KitchenAid® Food Chopper should fail within the first year of ownership, simply call our

toll-free Customer Satisfaction Center at **1-800-541-6390**, 8 a.m. to 8 p.m., Monday through Friday, 10 a.m. to 5 p.m., Saturday, Eastern Time. Give the consultant your complete shipping address. (No P.O. Box Numbers, please.)

When you receive your replacement Food Chopper, use the carton and packing materials to pack-up your "failed" Food Chopper. In the carton, include your name and address on a sheet of paper along with a copy of the proof of purchase (register receipt, credit card charge slip, etc.).

For a detailed explanation of warranty terms and conditions, including how to arrange for service outside the United States, see page 6.

## Proof of Purchase & Product Registration

---

Always keep a copy of the sales receipt showing the date of purchase of your Food Chopper. Proof of purchase will assure you of in-warranty service.

Before you use your Food Chopper, please fill out and mail your product registration card packed with the unit. This card will enable us to

contact you in the unlikely event of a product safety notification and assist us in complying with the provisions of the Consumer Product Safety Act. This card does not verify your warranty.

Please complete the following for your personal records:

Model Number \_\_\_\_\_

Serial Number \_\_\_\_\_

Date Purchased \_\_\_\_\_

Store Name \_\_\_\_\_

# Table of Contents

Hassle-Free Replacement Warranty.....	Inside Front Cover
Product Registration Card .....	Inside Front Cover
Important Safeguards.....	4
Warranty .....	5
For the 50 United States and District of Columbia.....	5
For Puerto Rico .....	6
Arranging for Service After the Warranty Expires.....	6
Arranging for Service Outside the 50 United States and Puerto Rico .....	6
Ordering Accessories and Replacement Parts .....	7
Electrical Requirements.....	7
Troubleshooting Problems .....	7
Chef's Chopper® Series Features .....	8
Chef's Chopper® Series Operating Instructions.....	10
Care and Cleaning .....	11
Operating Tips.....	11
Recipes.....	12

## **Your safety and the safety of others are very important.**

We have provided many important safety messages in this manual and on your appliance. Always read and obey all safety messages.



This is the safety alert symbol.

This symbol alerts you to potential hazards that can kill or hurt you and others.

All safety messages will follow the safety alert symbol and either the word "DANGER" or "WARNING." These words mean:



**You can be killed or seriously injured if you don't immediately follow instructions.**



**You can be killed or seriously injured if you don't follow instructions.**

All safety messages will tell you what the potential hazard is, tell you how to reduce the chance of injury, and tell you what can happen if the instructions are not followed.

# IMPORTANT SAFEGUARDS

---

When using electrical appliances, basic safety precautions should always be followed including the following:

1. Read all instructions.
2. To protect against risk of electric shock do not put Food Chopper in water or other liquid.
3. Close supervision is necessary when any appliance is used by or near children.
4. Unplug from outlet when not in use, before putting on or taking off parts, and before cleaning.
5. Avoid contacting moving parts.
6. Do not operate any appliance with a damaged cord or plug or after the appliance malfunctions, or is dropped or damaged in any manner. Return appliance to the nearest authorized service facility for examination, repair or electrical or mechanical adjustment.
7. The use of attachments not recommended or sold by KitchenAid may cause fire, electric shock, or injury.
8. Do not use outdoors.
9. Do not let cord hang over edge of table or counter.
10. Keep hands and utensils away from the cutting blade while chopping food to reduce the risk of severe injury to person or damage to the Food Chopper. A scraper may be used but only when the Food Chopper is not running.
11. Blade is sharp. Handle carefully.
12. To reduce the risk of injury, never place cutting blade on base without first putting bowl properly in place.
13. Be certain cover is securely locked in place before operating Food Chopper.
14. Do not attempt to defeat the cover interlock mechanism.
15. This product is designed for household use only.

## SAVE THESE INSTRUCTIONS

# KitchenAid® Chef's Chopper® Series Warranty for the 50 United States and District of Columbia

This warranty extends to the purchaser and any succeeding owner for Food Choppers operated in the 50 United States and District of Columbia.

Length of Warranty:	KitchenAid Will Pay For Your Choice of:	KitchenAid Will Not Pay For:
<p>One Year Full Warranty from date of purchase.</p>	<div data-bbox="443 340 593 488" data-label="Image"> </div> <p>Hassle-Free Replacement of your Food Chopper. See inside front cover for details on how to arrange for service, or call the Customer Satisfaction Center toll-free at <b>1-800-541-6390</b>.</p> <p>OR</p> <p>The replacement parts and repair labor costs to correct defects in materials and workmanship. Service must be provided by an Authorized KitchenAid Service Center. See the KitchenAid® Food Chopper Warranty for Puerto Rico on page 6 for details on how to arrange for service.</p>	<p>A. Repairs when Food Chopper is used in other than normal single family home use.</p> <p>B. Damage resulting from accident, alteration, misuse or abuse.</p> <p>C. Any shipping or handling costs to deliver your Food Chopper to an Authorized Service Center.</p> <p>D. Replacement parts or repair labor costs for Food Choppers operated outside the 50 United States and District of Columbia.</p>

**KITCHENAID DOES NOT ASSUME ANY RESPONSIBILITY FOR INCIDENTAL OR CONSEQUENTIAL DAMAGES.** Some states do not allow the exclusion or limitation of incidental or consequential damages, so this exclusion may not apply to you. This warranty gives you specific legal rights and you may also have other rights which vary from state to state.

## KitchenAid® Chef's Chopper® Series Warranty for Puerto Rico

---

A limited one year warranty extends to the purchaser and any succeeding owner for Food Choppers operated in Puerto Rico. During the warranty period, all service must be handled by an Authorized KitchenAid Service Center. Please bring the Food

Chopper, or ship it prepaid and insured, to the nearest Authorized Service Center. Call toll-free **1-800-541-6390** to learn the location of a Service Center near you. Your repaired Food Chopper will be returned to you prepaid and insured.

### Arranging for Service After the Warranty Expires

---

For service information, call toll-free **1-800-541-6390** or write to:  
Customer Satisfaction Center,

KitchenAid Portable Appliances, P.O.  
Box 218, St. Joseph, MI 49085-0218.

### Arranging for Service Outside the 50 United States and Puerto Rico

---

Consult your local KitchenAid dealer or the store where you purchased the

Food Chopper for information on how to obtain service.

### Ordering Accessories and Replacement Parts

---

To order accessories or replacement parts for your Food Chopper, call toll-free **1-800-541-6390** or write to:

Customer Satisfaction Center,  
KitchenAid Portable Appliances, P.O.  
Box 218, St. Joseph, MI 49085-0218.

## Electrical Requirements

---

Volts: 120V A.C. only  
Hertz: 60 Hz

**NOTE:** This Food Chopper has a polarized plug (one blade is wider than the other). To reduce the risk of electrical shock, this plug will fit in a polarized outlet only one way. If the plug does not fit fully in the outlet, reverse the plug. If it still does not fit, contact a qualified electrician. Do not modify the plug in any way.

A short power-supply cord is provided to reduce the risk resulting from becoming entangled in or tripping over a longer cord.

Extension cords are available and may be used if care is exercised in their use.

If a longer extension cord is used,

- The marked electrical rating of the extension cord should be at least as great as the electrical rating of the appliance.
- The cord should be arranged so it will not drape over the countertop or tabletop where it can be pulled on by children or tripped over unintentionally.

## Troubleshooting Problems

---

Keep a copy of the sales receipt showing the date of purchase. Proof of purchase will assure you of in-warranty service.

**If your Food Chopper should malfunction or fail to operate, check the following:**

- Is the Food Chopper plugged in?
- Is the fuse in the circuit to the Food Chopper in working order? If you have a circuit breaker box, be sure the circuit is closed.

- Unplug the Food Chopper, then plug it back into the outlet.
- If the Food Chopper is not at room temperature, wait until unit reaches room temperature and retry.
- If the problem is not due to one of the above items, see "Warranty" on page 5.
- Do not return the Food Chopper to the retailer. Retailers do not provide service.

# Chef's Chopper® Series Features

---

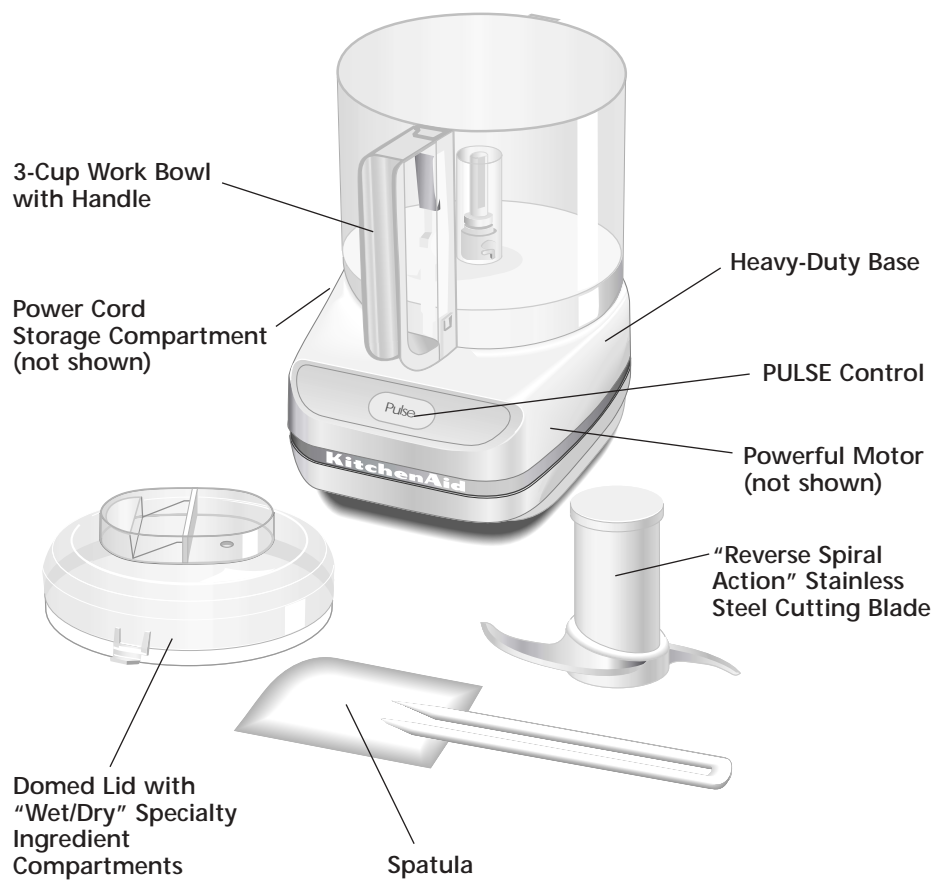

# Chef's Chopper® Series Features

---

**Domed Lid** must be locked in position to operate the chopper, but removes easily to add ingredients. Spices and flavorings may be added through "wet/dry" compartments located on lid top, without removing the lid. Lid is dishwasher safe.

**"Reverse Spiral Action" Stainless Steel Cutting Blade** is strong and razor sharp to quickly process small amounts of meats, fresh or cooked fruits and vegetables, and nuts and herbs. Reverse spiral design pulls foods down into blade for uniform chopping, and minimizes need to scrape sides of bowl. Blade is dishwasher-safe.

**Full 3-Cup Capacity Work Bowl** handles everyday processing needs. Dishwasher-safe.

**Convenient Bowl Handle** makes bowl removal easy.

**PULSE Control** provides precise, fingertip control of chopper operation.

**Heavy-Duty Base** keeps chopper stable during operation, helps prevent chopper "walk."

**Spatula** is included for your convenience.

**Round Power Cord** cleans easily.

**Power Cord Storage Compartment** under base provides convenient out-of-the-way storage for cord.

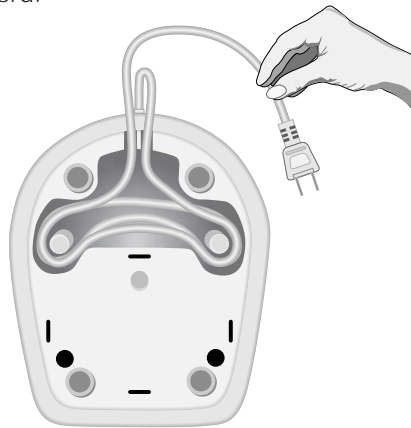

# Chef's Chopper® Series Operating Instructions

## Before First Use

1. Wash work bowl, lid and blade in hot, soapy water. Rinse and dry. The blade is sharp, so handle it carefully. Work bowl, lid and blade can also be washed in the dishwasher (top rack only).
2. Read *Chef's Chopper® Series Operating Tips* (Page 11.)

## Chef's Chopper® Series Use

1. Be sure the Food Chopper is unplugged.
2. Secure the work bowl to the base by placing bowl over center shaft with handle positioned to left of base. Bowl will drop down to contact base. Turn bowl counterclockwise until the handle locks into place over button at front of chopper.
3. Place blade in the work bowl over center shaft; rotate until blade drops into place. The blade is sharp; so handle it carefully.

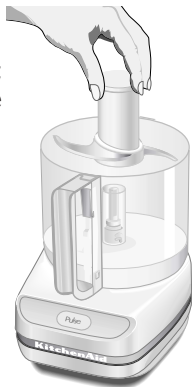

4. Place food to be processed in work bowl.
5. Place lid on work bowl. Turn lid counterclockwise until tab locks into place at handle.

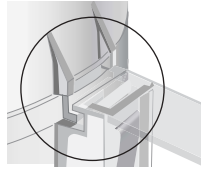

- NOTE:** Make sure both lid and work bowl are locked in position, otherwise your Food Chopper will not operate.
6. Plug power cord into electrical outlet. Press PULSE control to start processing.
  7. You can add spices and flavorings during processing without removing lid through the "wet/dry" compartments on lid top.
  8. To stop processing, release pressure on PULSE control.
  9. When blade stops spinning, remove lid by spinning it clockwise.
  10. Remove blade from work bowl. Be careful; blade is sharp.
  11. Unlock work bowl by turning it clockwise. Remove work bowl from heavy-duty base.
  12. Remove contents of work bowl with spatula.

## Care and Cleaning

---

### Chef's Chopper® Series Care and Cleaning Instructions

1. Unplug the Food Chopper.
2. Remove the work bowl, lid and blade. Wash in hot, soapy water. Rinse and dry. Work bowl, lid, and blade can also be washed in the top dishwasher rack.
3. Wipe the base clean with a damp cloth. Do not use abrasive cleaners. Do not immerse the base in water.
4. Reassemble your Food Chopper after cleaning to protect the blade.

### Chef's Chopper® Series Operating Tips

1. To achieve optimal results, fill the work bowl a maximum of  $\frac{2}{3}$  full for most foods. When chopping raw meat, chop up to  $\frac{3}{4}$  of a pound (300g) at one time. When adding liquid, use a maximum of  $\frac{3}{4}$  cup. Exceeding these quantities could result in damage to the Food Chopper.
2. For best processing results, press and release the PULSE control. Continue until ingredients reach the consistency you want.
3. Use your Food Chopper to make bread, cracker, or cookie crumbs. Break bread, crackers, or cookies into small pieces, add to work bowl and process into crumbs.

4. For uniform consistency of processed foods, cut carrots, celery, mushrooms, green peppers, onions and similar vegetables into 1-inch pieces before adding to work bowl.
5. Use your Food Chopper to chop nuts and mince parsley, basil, chives, garlic and other herbs.
6. Make baby food by using your Food Chopper to purée cooked fruit or vegetables. Puréed, cooked fruits and vegetables can also be used as bases for soups or sauces.
7. Do not use your Food Chopper to process coffee beans or hard spices such as nutmegs. Processing these foods could damage the Food Chopper.

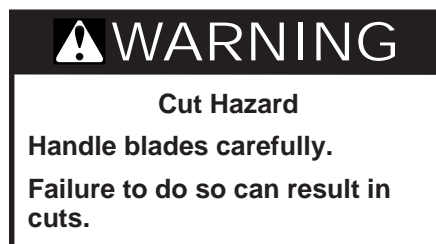

## HERBED GARLIC BUTTER

---

- ¼ small onion, cut in half*
- 2 cloves garlic*
- ½ cup loosely packed parsley leaves*
- ¼ cup loosely packed fresh basil leaves*
- ¼ cup fresh oregano leaves*
- ½ teaspoon salt*
- ¼ teaspoon coarsely ground black pepper*
- 2 tablespoons extra virgin olive oil*
- ½ cup butter or margarine, softened*

Combine onion, garlic, parsley, basil, oregano, salt, pepper, and olive oil in chopper. Process 10 seconds to chop. Add butter; pulse 3 to 4 times for 10 seconds each to blend. On plastic wrap, form mixture into log (mixture will be soft); roll up. Refrigerate until chilled and set.

Serve on hard rolls and crackers. Use as fish, chicken, or vegetable seasoning.

Yield: 10 servings (2 tablespoons per serving).

Per serving: About 111 cal, 0 g pro, 1 g carb, 12 g fat, 25 mg chol, 119 mg sod.

## GUACAMOLE

---

- 3 green onions, cut into 1-inch pieces*
- 1 clove garlic*
- 2 serrano chiles, seeded and cut into quarters*
- ¼ cup loosely packed fresh cilantro*
- 2 Roma tomatoes, seeded and cut into quarters*
- 2 ripe avocados, seeded and cut into quarters*
- ½ teaspoon salt*
- 1 tablespoon fresh lime juice*

Combine onion, garlic, chiles, and cilantro in chopper; process 5 seconds to chop. Add tomatoes, avocados, salt, and lime juice; pulse 3 to 4 times for 10 seconds each to chop avocado and tomato. Serve on Mexican foods and chips.

Yield: 8 servings (2 tablespoons per serving).

Per serving: About 61 cal, 1 g pro, 3 g carb, 5 g fat, 0 mg chol, 102 mg sod.

## HUMMUS

---

- 1 clove garlic
- 1 tablespoon fresh parsley leaves, if desired
- 1 small green onion, cut into 1-inch pieces
- 1 (15 oz.) can garbanzo beans, drained and liquid reserved
- 1 tablespoon extra virgin olive oil
- 1 tablespoon tahini (toasted sesame paste), if desired
- $\frac{3}{4}$  teaspoon dark sesame oil
- 2 tablespoons lemon juice
- $\frac{1}{4}$  teaspoon dried oregano leaves
- $\frac{1}{8}$  teaspoon cayenne pepper

Place garlic and parsley in chopper; process 3 to 5 seconds to chop. Add onion, garbanzo beans, 1 tablespoon reserved bean liquid, olive oil, tahini, sesame oil, lemon juice, oregano, and pepper; pulse 3 to 5 times for 10 seconds until smooth, adding 1 to 2 tablespoons reserved bean liquid if beans are not chopping evenly after the second pulse.

Place in serving bowl. Serve with vegetable dippers, pita bread, or cracker bread.

Yield: 11 servings (2 tablespoons each).

Per serving: About 46 cal, 2 g pro, 5 g carb, 2 g fat, 0 mg chol, 105 mg sod.

## HERBED VINAIGRETTE

---

- $\frac{1}{2}$  cup loosely packed parsley leaves
- $\frac{1}{2}$  cup loosely packed basil leaves
- $\frac{2}{3}$  cup extra virgin olive oil
- $\frac{1}{4}$  cup white wine vinegar or white balsamic vinegar
- 1 small shallot, cut into halves
- 1 clove garlic
- $\frac{1}{4}$  teaspoon salt
- $\frac{1}{4}$  teaspoon pepper

Place all ingredients in chopper and process 20 seconds, or until blended.

Yield:  $\frac{3}{4}$  cup. 6 servings (2 tablespoons per serving).

Per serving: About 231 cal, 0 g pro, 1 g carb, 25 g fat, 0 mg chol, 101 mg sod.

## CHICKEN SALAD SPREAD

---

- 2 *boneless, skinless chicken breast halves, cooked\* and cut into quarters (2-inch pieces)*
- $\frac{1}{4}$  *stalk celery, cut into 1-inch pieces*
- 1 *green onion, cut into 1-inch pieces*
- $\frac{1}{8}$  *cup light or regular mayonnaise*
- 1 *teaspoon Worcestershire sauce*
- $\frac{1}{4}$  *teaspoon salt*
- $\frac{1}{4}$  *teaspoon garlic powder*
- $\frac{1}{8}$  *teaspoon coarsely ground black pepper*
- 2 *tablespoons slivered almonds*

Place chicken, celery, and onion in chopper; pulse 5 to 6 times for 3 seconds each to chop. Add mayonnaise, Worcestershire sauce, salt, garlic powder, and pepper; process 2 to 3 seconds to mix. Add almonds; process 2 seconds to mix.

Yield: 3 servings (scant  $\frac{1}{2}$  cup per serving).

\*To cook chicken: In medium skillet, combine chicken (lightly salt and pepper, if desired) and 1 inch water. Bring to a boil. Cover and reduce heat. Simmer for 10 to 15 minutes, or until chicken is no longer pink in center. Drain; cool slightly.

Per serving: About 201 cal, 20 g pro, 4 g carb, 11 g fat, 56 mg chol, 416 mg sod.

## FRESH TOMATO SALSA

---

- $\frac{1}{2}$  *small onion, cut into 1-inch pieces*
- 1 *jalapeño pepper, seeded and cut into quarters*
- 1 *clove garlic*
- $\frac{3}{4}$  *pound Roma tomatoes (about 5 tomatoes), seeded and cut into eighths*
- $\frac{1}{4}$  *cup loosely packed fresh cilantro*
- 1 *tablespoon olive oil*
- 1 *tablespoon lime juice*
- $\frac{1}{2}$  *teaspoon salt*

Place onion, pepper, and garlic in chopper; process 3 to 5 seconds to chop. Add tomatoes, cilantro, oil, lime juice, and salt; pulse 6 to 8 times for 2 seconds each to chop, or until desired consistency.

Yield:  $1\frac{1}{2}$  cups. 12 servings (2 tablespoons per serving).

Per serving: About 17 cal, 0 g pro, 2 g carb, 1 g fat, 0 mg chol, 100 mg sod.

## HOMEMADE MAYONNAISE

---

- 1 *pasteurized egg*
- $\frac{1}{2}$  *teaspoon salt*
- $\frac{1}{2}$  *teaspoon sugar*
- $\frac{1}{2}$  *teaspoon dry mustard*
- 8 *drops hot pepper sauce*
- 2 *tablespoons lemon juice*
- 1 *cup vegetable oil*

Place egg, salt, sugar, mustard, pepper sauce, and 1 tablespoon lemon juice in chopper. Process 5 seconds to blend. Through small opening in lid and with chopper running, slowly pour in half of oil. Continuing to process, add remaining lemon juice and remaining oil until mayonnaise is thick and smooth; process until all oil is incorporated.

Yield: About  $1\frac{1}{2}$  cups. 24 servings (1 tablespoon per serving).

Per serving: About 85 cal, 0 g pro, 0 g carb, 9 g fat, 9 mg chol, 54 mg sod.

### VARIATION

#### Chipolte Mayonnaise

Prepare as directed above. Add 1 tablespoon chipolte chile in adobo sauce and  $\frac{1}{4}$  teaspoon adobo sauce to mayonnaise; process to blend.

Per serving: About 84 cal, 0 g pro, 0 g carb, 9 g fat, 9 mg chol, 51 mg sod.

#### Lemon Dill Mayonnaise

Begin by placing 2 tablespoons lightly packed fresh dill in chopper; process 4 to 5 seconds to chop. Add egg,  $\frac{1}{2}$  teaspoon grated lemon peel, salt, sugar, mustard, pepper sauce, and 1 tablespoon lemon juice. Continue as directed above.

Per serving: About 84 cal, 0 g pro, 0 g carb, 9 g fat, 9 mg chol, 51 mg sod.

## MANGO SAUCE

---

- 2 *ripe mangoes, peeled, pitted, and cut into 1-inch pieces*
- 3 *tablespoons freshly squeezed orange juice*
- 3 *tablespoons powdered sugar*

Place all ingredients in chopper. Pulse 2 to 3 times for 10 seconds each until blended. Serve over ice cream, fruit, or pound cake.

Yield:  $1\frac{1}{2}$  cups. 6 servings ( $\frac{1}{4}$  cup per serving).

Per serving: About 63 cal, 0 g pro, 16 g carb, 0 g fat, 0 mg chol, 1 mg sod.

## PINEAPPLE JALAPEÑO SALSA

---

<i>½ jalapeño pepper, seeds removed</i>	Place pepper, onions, and ginger in chopper. Process 3 to 5 seconds to chop. Add pineapple, salt, and cumin; pulse 4 to 5 times for 3 seconds each to coarsely chop pineapple. Serve with chicken or pork. Yield: 1½ cups. 12 servings (2 tablespoons per serving). Per serving: About 15 cal, 0 g pro, 4 g carb, 0 g fat, 0 mg chol, 49 mg sod.
<i>2 green onions, cut into 1-inch pieces</i>	
<i>1 tablespoon crystallized ginger</i>	
<i>2 cups fresh pineapple chunks</i>	
<i>¼ teaspoon salt</i>	
<i>¼ teaspoon cumin</i>	

## GARLIC-GINGER MARINADE

---

<i>3 tablespoons vegetable oil</i>	Combine all ingredients in chopper. With hand on top of chopper, process 10 to 15 seconds until blended. Place beef, pork, chicken, fish, or tofu in dish or sealable food storage bag. Marinate 1 hour (for fish, tofu, or small pieces of meat) or 8 hours to overnight (for larger cuts of meat). Grill or broil to desired doneness, brushing once with marinade halfway through cooking, if desired. Discard remaining marinade. Yield: About ¾ cup (enough to marinate approximately 1½ pounds of steak or 6 chicken breasts). Per serving: About 36 cal, 0 g pro, 1 g carb, 3 g fat, 0 mg chol, 286 mg sod.
<i>3 tablespoons rice wine vinegar</i>	
<i>¼ cup loosely packed fresh cilantro leaves</i>	
<i>1 tablespoon onion pieces</i>	
<i>3 tablespoons soy sauce</i>	
<i>2 teaspoons dark sesame oil</i>	
<i>½ teaspoon sugar</i>	
<i>¼ teaspoon crushed red pepper flakes</i>	
<i>1 inch piece fresh gingerroot</i>	
<i>2 cloves garlic</i>	

## BUTTERCREAM FROSTING

---

<i>½ cup butter or margarine, softened</i>	Place butter, shortening, sugar, salt, vanilla, and 2 tablespoons milk in chopper. Pulse 4 to 5 times for 10 seconds each to mix. Through small opening in lid, add additional milk 1 tablespoon at a time, pulsing until smooth between additions, until desired consistency.
<i>½ cup shortening</i>	
<i>2 cups powdered sugar</i>	
<i>Dash salt</i>	
<i>1 teaspoon vanilla</i>	
<i>2-4 tablespoons milk</i>	Yield: 12 to 16 servings (frosting for 2-layer or 13x9x2-inch cake).
	Per serving: About 207 cal, 0 g pro, 17 g carb, 16 g fat, 21 mg chol, 14 mg sod.

## CHOCOLATE GLAZE

---

<i>1 cup powdered sugar</i>	Place sugar, cocoa, salt, and butter in chopper. Pulse 1 to 2 times for 5 seconds each to mix. Add 2 tablespoons milk and vanilla; pulse 4 to 5 times for 3 seconds each until smooth. Through small opening in lid, add additional milk 1 teaspoon at a time, if necessary, to reach drizzling consistency. Drizzle over cake or cupcakes.
<i>¼ cup cocoa</i>	
<i>Dash salt</i>	
<i>1 tablespoon butter or margarine</i>	
<i>2-3 tablespoons milk</i>	
<i>½ teaspoon vanilla</i>	Yield: 12 servings (glazes 2-layer or 13x9x2-inch cake or 12 cupcakes).
	Per serving: About 47 cal, 0 g pro, 9 g carb, 1 g fat, 3 mg chol, 14 mg sod.

## CRISP NUT DESSERT TOPPING

---

- ½ cup packed brown sugar*
- ¼ cup all-purpose flour*
- 1 teaspoon cinnamon*
- ¼ teaspoon nutmeg*
- 3 tablespoons butter or margarine, cut up*
- ½ cup old-fashioned rolled oats*
- 1 cup walnut or pecan pieces*

Place sugar, flour, cinnamon, and nutmeg in chopper; process 3 to 4 seconds to mix. Add butter; pulse 1 or 2 times for 4 seconds each to blend. Add oats and nuts; pulse 3 to 4 times for 4 seconds each to mix. Spread mixture on baking sheet. Bake at 375°F for 15 to 20 minutes, or until golden brown, stirring occasionally.

Cool completely; break apart. Sprinkle over ice cream, fruit, or prepared pie filling. Store in cool dry place in tightly covered container.

Yield: About 2 cups. 8 servings (¼ cup per serving).

Per serving: 198 cal, 3 g pro, 16 g carb, 14 g fat, 12 mg chol, 5 mg sod.

## DECADENT TRUFFLE SCOOPS

---

- 1 cup semi-sweet chocolate chips*
- 1 cup whipping cream*
- 2 tablespoons coffee liqueur or raspberry juice concentrate*
- 1 cup fresh raspberries*  
*Whipped topping, if desired*

Place chocolate in chopper; pulse 5 to 6 times for 5 seconds each to chop. In small saucepan, heat cream until hot but not boiling. Through either opening in lid and with chopper running, slowly add cream. Process 20 to 30 seconds until smooth. Through either opening and with chopper running, add liqueur; process until smooth.

Chill several hours until set. Scoop 2 small scoops into individual dessert dishes. Top with raspberries and whipped topping, if desired.

Yield: 16 servings.

Per serving: About 111 cal, 1 g pro, 10 g carb, 8 g fat, 20 mg chol, 6 mg sod.



FOR THE WAY IT'S MADE.™

® Registered Trademark/™ Trademark of KitchenAid, U.S.A.