

Crane

INSTRUCTION MANUAL

2.1 GALLON/ 7.56 LITER ULTRASONIC HUMIDIFIER

MODEL# EE-864



PLEASE READ AND SAVE ALL INSTRUCTIONS TO ENSURE THE SAFE AND EFFECTIVE USE OF THIS APPLIANCE.

TABLE OF CONTENTS

Table of Contents	P.1
Important Safety Instructions	P. 2
General Safety Instructions	P.3
List of Main Parts	P.4
Tech. Specifications, Contents of Packaging	P.5
Operation and Use	P.5-7
Maintenance	P.8-9
Trouble Shooting, Service Center Information	P.10
Warranty Information	P.11
Warranty Card	P.12



IMPORTANT SAFETY INSTRUCTIONS

INTRODUCTION

Thank you for purchasing our CRANE Ultrasonic Humidifier. Each unit has been manufactured to ensure safety and reliability. Before using the humidifier for the first time, please read the instructions carefully, and keep them for further reference.

WARNING! READ AND SAVE THESE INSTRUCTIONS. Failure to follow all the instructions listed below may result in electric shock, fire and/or serious personal injury.

1. **Do not carry water tank by handle when it is filled with water. It is advisable to carry filled water tank with two hands.**
2. **DO NOT operate outdoors; this humidifier is intended for indoor use only.**
3. Always have water in the water tank when operating the unit.
4. Use only clean, cool tap water to fill the tank (filtered or distilled water is recommended to avoid white dust if tap water is too hard). DO NOT use hot water.
5. Be sure that the filling cap of the tank is firmly tightened. Always have the mist direction nozzle and the mist chamber in place while the unit is operating. Place the mist direction nozzle so it aims away from children, walls, furniture, and electrical appliances.
6. Use only a 110-120VAC outlet. **ALWAYS plug and unplug unit with dry hands.**
7. Never operate the unit with a damaged cord or plug.
8. Always place the unit on a smooth, lint free, non-metallic, waterproof, level surface, and away from direct sunlight. Keep the cord away from heated surfaces and areas where it could be walked on or tripped over. Unplug the unit when not in use and whenever you clean or move the unit.
9. Do not add medication of any type into the nozzle, base or water tank. Do not cover any openings on the unit or insert objects into any openings.
10. The unit should not be left unattended in a closed room as the air could become saturated and leave condensation on walls or furniture. Leave room door partly open.
11. When cleaning the inside of the unit keep water away from the air outlet /fan vent. The exterior may be wiped with a damp cloth, except the electrical controls, **only when the unit is off and unplugged.** Humidifier requires regular cleaning. Refer to cleaning instructions.
12. Do not tilt or tip the unit or attempt to empty or fill it while it is in operation.
13. Do not use a detergent to clean any parts of the unit that contain water. Always use a few drops of bleach with water to clean humidifier. Detergent film dissolved in the water supply can interfere with the output of the unit.

SAVE THESE INSTRUCTIONS!

GENERAL SAFETY INSTRUCTIONS



WARNING! Read and understand all instructions. Failure to follow all instructions listed below may result in electric shock, fire or serious personal injury. The warnings, cautions, and instruction discussed in this instruction manual cannot cover all possible conditions and situations that may occur. It must be understood by the operator that common sense and caution are a factor which cannot be built into this product, but must be supplied by the operator.

THIS HUMIDIFIER IS NOT A TOY!

Do not let your child play with this appliance. Serious injury and electrocution might be possible. This appliance has to be operated by an adult only. Children should be supervised to ensure that they do not play with the humidifier.

SAVE ALL INSTRUCTIONS!

CAUTION: A short power supply cord is provided to reduce the risk of personal injury resulting from becoming entangled in or tripping over a longer cord. Extension cords are available from local hardware stores and may be used if care is exercised in their use. If an extension cord is required, special care and caution is necessary. Also the cord must be: (1) marked with an electrical rating of 125 V and at least 13 A., 1625 W., and (2) the cord must be arranged so that it will not drape over the countertop or tabletop where it can be pulled on by children or tripped over accidentally.

ELECTRIC POWER

If electric circuit is overloaded with other appliances, your appliances may not operate properly. The appliances should be operated on a separate electrical circuit from other operating appliances.

POLARIZED PLUG

This appliance has a polarized plug (one blade is wider than the other). As a safety feature to reduce the risk of electrical shock, this plug is intended to fit in a polarized outlet only one way. If the plug does not fit fully in the outlet, reverse the plug. If it still does not fit, contact a qualified electrician. Do not attempt to defeat this safety feature.



SAFETY WARNING



Although your appliance is easy to operate, for your safety, the below warnings must be followed:

1. Do not place the appliance near a heat source.
2. Never leave the appliance unattended while connected to the electrical outlet.
3. To avoid any accidents, never put a hand over a steam/heat vent and never cover it when the appliance is in operation.
4. Use the appliance on a stable surface away from water.
5. Do not unplug from the wall socket by pulling on the supply cord.
6. The appliance must be unplugged:
 - A. Before either filling or emptying
 - B. Before any cleaning or maintenance
 - C. After use
 - D. If it appears to be faulty

THIS PRODUCT IS INTENDED FOR HOUSEHOLD USE ONLY.

LIST OF MAIN PARTS

PARTS DESCRIPTION

Fig. 1 (Central Body)

1. On/Off Switch
2. Regulator Control Knob
3. Central Body with water basin
4. Red/Refill Light
5. Green/Power Light

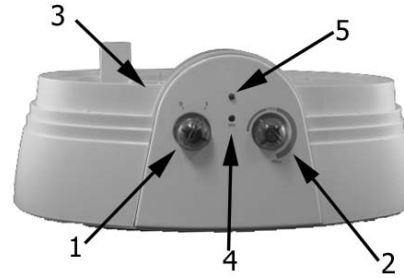

Fig. 1

Fig. 2 (Top of Water Tank)

6. Vapor Outlet Channel
7. Water Tank Handle



Fig. 2

Fig. 3 (Water Basin)

8. Nebulizer
9. Vaporization Chamber
10. Fan Vent
11. Valve Opener
12. Water Level Sensor

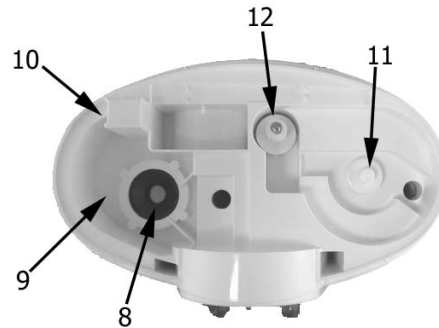

Fig. 3

Fig. 4 (Bottom of Water Tank)

13. Water Tank Valve
14. Water Tank Cap
15. Vapor Outlet Channel

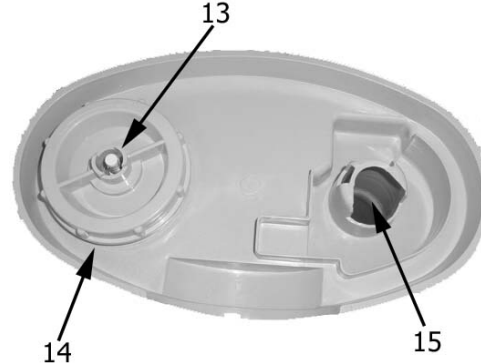

Fig. 4

Fig. 5 (Water Tank Lid)

16. Water Tank Lid
17. Vapor Output Slot

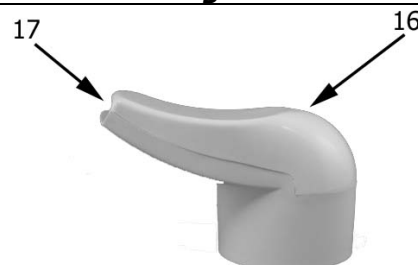

Fig. 5

TECHNICAL SPECIFICATIONS:

Rating Voltage	120V
Frequency	60Hz
Power	30W
Water Tank Capacity	Approx. 1.5 Gallon / 5.5 Liter
Output Per 24 Hours	Approx. 2.1 Gallon / 7.56 Liter
Run Time Per Tank	Min. 18 Hours
Humidifying Capacity	Up to 250 sq.ft. / 23 m ²
Noise	< 36.5 (dB) A

CONTENTS OF PACKAGING

- a. Instruction Manual
- b. Central Humidifier Body
- c. Water Tank
- d. Water Tank Lid with Vapor Output Slot

If any of the above items are missing, please contact our service department at 1-888-599-0992 (<http://www.crane-usa.com>) for replacement. Business hours Mon-Fri 9:00am - 4:00pm CT

OPERATION AND USE

BEFORE EACH USE

CHECK HUMIDIFIER PLACEMENT - Place the Humidifier on an elevated non-metallic, lint free, waterproof, level surface for best performance. This is to help disperse the mist in the air, and prevent it from being knocked or tipped over.

CHECK WATER LEVEL SENSOR - Make sure that the water level sensor is secured properly. Refer to "cleaning and maintaining water level sensor" on page 9 for instructions on how to assemble water level sensor.

CHECK FAN VENT - This fan vent is located on the bottom of the humidifier. The purpose of the Fan Vent is to blow the cool mist through the vapor outlet slots. It is important that this part is kept clean and free of obstructions. We recommend checking the fan vent before using this item (i.e. lint, paper)

Do not place Humidifier on top of a towel, or a carpeted surface. The air vent on the bottom may become blocked, and overheat the humidifier.

CAUTION:

**DO NOT operate the humidifier without water in the water tank.
DO NOT plug in the cord with wet hands; electric shock could happen**

ASSEMBLY

1. Lift the water tank off the central body.
2. Turn over the water tank and unscrew the water tank cap at the bottom of the tank by turning it counterclockwise. **(See Fig. 6)**



Fig. 6

3. Fill water tank with cold water; do not fill all the way to the rim. **DO NOT CARRY FULL WATER TANK BY HANDLE.** ALWAYS HOLD FULL WATER TANK WITH TWO HANDS ON EITHER SIDE OF WATER TANK. **(See Fig. 7)**



Fig. 7

Note: To avoid possible white dust due to hard water it is recommended to use filtered or distilled water.

DO NOT use hot water. Use cool tap water.

DO NOT add any medication to other additives to the water

DO NOT pour water into Vapor Outlet Channel (part 6, Fig.2 on page 4)

4. Replace the water tank cap, aligning the threads on the tank with the threads on the cap, and turn it clockwise. **(See Fig. 8)**



Fig. 8

5. Turn the tank over, holding one hand by the top handle and another hand under tank. Place full water tank on the central body, making sure it fits perfectly. Place the water tank lid with output slot on top of the water tank. **(see Fig. 9)**



Fig. 9

6. Plug the power cord into a wall socket and turn on the unit. The On/Off switch is located at the central body. **(see figure 1).**

7. The Power Light will turn on red. In a few seconds it will switch to green, indicating that enough water is in the water basin, and vapor will start emitting through the openings at water tank lid.
8. Use the regulator control knob to adjust the intensity of the vapor output. Turning the knob clockwise will increase the moisture output, turning the knob counterclockwise will reduce the moisture output.
9. When the humidifier runs out of water the power light will turn red, and the mist output will stop. This is a safety feature to prevent the humidifier from possibly overheating and damaging the nebulizer. This safety feature uses a water level sensor to stop the nebulizer once the water level sinks below the required level in the water basin. *Please note that the RED Power Light on the humidifier body will stay on. The (red) light signal indicates that the humidifier is turned on and needs to be refilled.* Turn the humidifier off and unplug before removing and refilling the water tank.

SET THE CORRECT HUMIDITY OUTPUT

ALWAYS PLACE THE HUMIDIFIER ON AN ELEVATED NON-METALLIC LINT FREE, WATERPROOF, LEVEL SURFACE FOR BEST PERFORMANCE.

Adjust the vapor control so that the vapor rises up and gets absorbed by the room air. Do not turn on too high output as the vapor cannot be absorbed by the air and accumulates on the surface around the humidifier.

If the humidifier is placed near a fan or air conditioning outlet the vapor may be forced down by the foreign air stream. Change the location of the humidifier or reduce the output of the other room conditioning appliances.

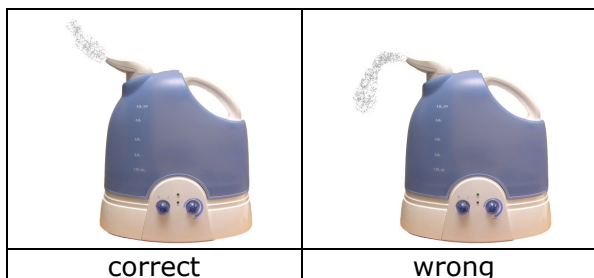

A NOTE ABOUT HUMIDITY

- It is best to keep the humidity level at about 30-50 percent of relative humidity.
- The comfort level of humidity will vary from room to room and with changing room conditions.
- In cold weather, windows and even some walls may fog or develop frost from excessive indoor humidity. If this occurs, reduce the mist intensity setting to avoid damage from condensed water dripping on windowsills.
- Too much humidity in the room may allow moisture to accumulate on surfaces where bacteria and fungi can grow. Moisture that gathers may also damage furniture and walls, especially wallpaper.
- To eliminate excessive humidity, especially in small rooms, leave the room door open and adjust the mist intensity control setting.

MAINTENANCE



CAUTION:

Always be sure that the appliance is unplugged and switched OFF before cleaning or attempting to store the item. NEVER PLUG OR UNPLUG UNIT WITH WET HANDS.

DO NOT leave water in water tank or water basin when unit is not in use as it may result in the build up of mineral deposits and bacteria that can inhibit the output efficiency of the humidifier.

PLEASE NOTE that if water remains in the water tank for more than a day or two, bacterial growth is possible.

ALWAYS use fresh cool water when using unit.

NOTE: When removing water tank, water may accumulate under vapor lid and on the bottom of the water tank. It is recommended to have a dry cloth ready to dry wet surfaces.

DISINFECTING THE WATER TANK AND WATER BASIN

1. Fill water tank with 1 teaspoon of household bleach or white vinegar in 1 gallon of water. Let stand twenty minutes, shaking vigorously with two hands every few minutes, drain and rinse with clean water until the bleach or vinegar smell is gone. Dry with a clean cloth or paper towel.
2. Wipe the water basin with a soft cloth dampened in the bleach or white vinegar and water solution. Rinse the water basin with cool water to remove any smell. **DO NOT IMMERSE WATER BASIN IN WATER.**
3. Wipe all exterior surfaces of the base with a soft, dry cloth. Do not immerse the base in water or use water to clean the base. An electric shock may result or the humidifier may be damaged.

GENERAL MAINTENANCE AND CLEANING

Before any cleaning operation, switch the humidifier off and unplug it.

1. Always unplug the unit before cleaning.
2. The humidifier must be drained and cleaned before storing.
3. Once unplugged the exterior of the unit may be cleaned by wiping with a dry cloth.
Caution: The ON/OFF switch must be thoroughly dry before unit is again plugged into power source.
4. There may be some lime deposits in the nebulizer, particular in areas with hard water. Overcome this drawback by cleaning the nebulizer with water and vinegar on a soft cloth regularly, as follows:
 - A. Dampen a cloth with a few drops of white vinegar or bleach water solution and wipe the nebulizer gently, until the lime deposits disappear completely.
 - B. Rub down gently with a dry cloth and remove remains of humidity.
 - C. Do not rub the nebulizer with solid objects.
 - D. Do not clean with chemical products.

5. When cleaning the water basin do not place the nebulizer directly under the water tap.
6. Never immerse the unit in water or let water enter the fan vent or any other openings.
7. It is normal for water to be in the water basin. However water must not get inside the central body. If this should happen, take the humidifier to an authorized service center before using it again.
8. Clean the inside of the water tank at least once a week, as follows:
 - A. Fill the tank with clean water adding a few drops of bleach or white vinegar with water solution. Close the tank completely with its cap and shake by holding the tank with both hands. Do not hold by handle while shaking the tank.
 - B. Rinse thoroughly.

Note: Water accumulated over long periods may create bacteria and mildew (fungus). It is important to remove the water in the humidifier if the humidifier is not being used. Always use fresh clean water when filling the water basin.

9. To clean the water float unscrew (**see Fig.11**) the plastic cap on the pin by pulling it up (**see Fig.12**). Remove the water float and cap and clean by wiping the parts with a soft damp cloth. Replace the parts by first putting the water float onto the pin and then pressing the plastic cap on the end of the pin to secure the float. (**see Fig.13**). Do not use excessive force.



Fig. 11

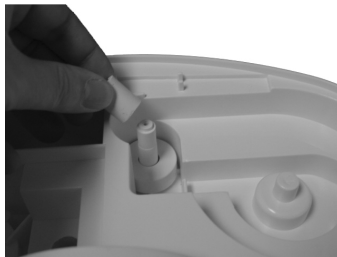

Fig. 12

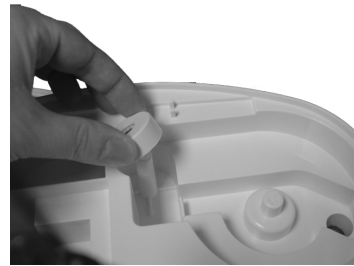

Fig. 13

STORING YOUR HUMIDIFIER

Allow the appliance to dry completely before storing. Store the appliance in a dry location. Do not place any heavy items on top of appliance during storage as this may result in possible damage of the appliance. Store the cord in a clean, dry location away from metal objects. Always check the plug before use to assure metal items have not become attached.

- Save the box for off-season storage.
- Make sure the tank, water basin and water tank cap are thoroughly dry before storing.
- If water is left in the unit during storage, it may evaporate completely and leave deposits that can prevent the unit from operating properly.
- Leave the water tank refill cap loose to prevent the water cap and gasket from sticking together. NOTE: The gasket is the white rubber ring inside the water tank cap. Keeping the cap loose will prolong the life of the gasket.

TROUBLE SHOOTING

CAUTION: DO NOT attempt to repair the motor or nebulizer yourself. If the humidifier continues to not operate please call our service center (see toll free number below).

Problem	Solution
<i>Humidifier Light is staying red and not turning green</i>	<ul style="list-style-type: none">▪ Ensure that water level float is assembled properly.▪ Clean water float
<i>If humidifier does not work at all:</i>	<ul style="list-style-type: none">▪ Ensure it is properly plugged into a power outlet.▪ Check that the switch is in the ON position.▪ If Power On indicator light does not come on, bring to authorized service station.
<i>If there is a strange odor:</i>	<ul style="list-style-type: none">▪ Clean the tank with water and white vinegar or bleach water solution and rinse with clean water.▪ Leave the tank open for some time without the cap, in a cool place.
<i>The power light is green but there is no mist being emitted:</i>	<ul style="list-style-type: none">▪ Check that there is water in the tank.▪ Check for possible lime deposits on the water level float or the nebulizer.▪ Make sure that nothing blocks the vapor output slot.▪ Check that the air vent on bottom of humidifier is not blocked.▪ Empty the humidifier and rinse the water basin with cool tap water and allow to dry for 15 to 30 min.
<i>White dust appears and settles outside the humidifier:</i>	<ul style="list-style-type: none">▪ Area tap water may have too many minerals, change to filtered or distilled water.

SERVICE CENTER

If you have any question in regards to the operation of this appliance or are in need of a spare part please contact our service center at:

Crane USA Inc.

Tel: 1-888-599-0992 (Business Hours Mon-Fri 9:00am-4:00 pm Ct)

Website: <http://www.crane-usa.com>

1800 Nicholas Blvd

Elk Gove Village, Illinois 60007

ENVIRONMENTAL PROTECTION

If the appliance should no longer work at all, please make sure that it is disposed in an environmentally friendly way, by handing it into a public collection point. Please do not put it with your household waste.



LIMITED WARRANTY

Thank you for purchasing a top quality **Crane** product. This Ultrasonic Humidifier was tested and meets our stringent quality standards. This product is warranted to be free from manufacturing defects under normal use and conditions for 1 year.

In case you find this product to have a manufacturing defect please proceed as follows:

- A. Within 90 days of purchase: return the product to your retailer for a replacement or a refund.
- B. After 90 days and within the warranty period: send the product and all of it's accessories to our service center. The consumer will be responsible for all shipping costs to the Crane Service Center. Crane will not assume responsibility for loss or damages to the product being returned to us. To avoid transport damages carefully package the product and insure it with the carrier. Be sure to fill out the warranty card and include it with a copy of the dated sales receipt. In return you will receive your repaired item, or a new product at the service center's discretion.

WARRANTY IS ONLY VALID WITH A DATED PROOF OF PURCHASE.

The warranty is void if the defect is due to accidental damage, misuse, abuse, neglect, improper repair or alteration by unauthorized persons or failure to follow operation instructions provided with the product. This warranty does not apply to normal wear and tear, as well as commercial use.

The warranty is non-transferable and applies only to the original purchase and does not extend to subsequent owners of the product. Liability under this warranty is limited to repair, or replacement. In no event shall liability exceed the purchase price paid by the purchaser of the product. Under no circumstances shall there be liability for any loss, direct, indirect, incidental, special or consequential damage arising out of in connection with use of this product.

This warranty is only valid in the 48 contiguous states plus the District of Columbia. Excluding Alaska, Hawaii, Puerto Rico, and the Virgin Islands. This warranty is effective only if the product is purchase and operated in the United States of America.

This Warranty gives you specific legal rights. However you may have other rights that vary from state to state. Some states do not allow limitation on implied warranties or exclusion of consequential damages therefore these restrictions may not apply to you.

Any instruction or warranty included in this manual may be subject to change without notice. For the most up to date set of instructions and warranty please contact us or visit our web site.

Crane USA Inc.

Tel: 1-888-599-0992 (Business Hours Mon-Fri 9:00am-4:00 pm CT)

Website: <http://www.crane-usa.com>

1800 Nicholas Blvd

Elk Grove Village, Illinois 60007

WARRANTY CARD



Ultrasonic Humidifier

In case you find this product to be defective please proceed as follows:

- A. Within 90 days of purchase: return the product to your retailer for a replacement or a refund.
- B. After 90 days and within the warranty period: send the product and all of it's accessories to our service center. The consumer will be responsible for all shipping costs to the Crane Service Center. Crane will not assume responsibility for loss or damages to the product being returned to us. To avoid transport damages carefully package the product and insure it with the carrier. Be sure to fill out the warranty card and include it with a copy of the dated sales receipt. In return you will receive your repaired item, or a new product at the service center's discretion.

This Ultrasonic Humidifier was tested and meets our stringent quality standards. This product is warranted to be free from manufacturing defects in original materials, including original parts, and workmanship for 1 year with proof of purchase.

Please print clearly and fill in your details below. Send it together with the product and purchase receipt. Please read the Limited Warranty conditions mentioned in this instruction manual.

Customer Name	
Street	
City	
State	
ZIP Code	
Phone #	
Model #/Style	
Purchase Date	
Description of Defect :	

Service Center Address:

Crane USA Inc.

1800 Nicholas Blvd Elk Grove Village, Illinois 60007

Tel: 1-888-599-0992 (Business Hours Mon-Fri 9:00am-4:00 pm

CT)Website: <http://www.crane-usa.com>

PLEASE DETACH THIS SECTION AND RETURN IT WITH YOUR PRODUCT

WARRANTY CARD



