

This Owner's Manual is provided and hosted by [Appliance Factory Parts](#).



# DCS DCS48A-BQAR Owner's Manual

[Shop genuine replacement parts for DCS  
DCS48A-BQAR](#)



[Find Your DCS Grill Parts - Select From 274 Models](#)

----- Manual continues below -----

# The Professional Grill

INSTALLATION AND USER MANUAL  
Professional 27", 36", 48" Grill Models



*Dynamic Cooking Systems, Inc.*



MADE IN THE  
U.S.A.

FOR OUTDOOR USE ONLY

## A Message to Our Customers

We are glad you selected the Professional Grill by Dynamic Cooking Systems. Because this appliance contains features not found on any other grill, we recommend that you read this entire booklet before your first use. Keep it in a handy place as it has answers to questions that may occur during future use.

Feel free to contact us if we can help you. When you write please include the model number of the grill.

We thank you for buying the "Made in America" Professional Grill and wish you many years of enjoyment.



Dynamic Cooking Systems, Inc.

### IMPORTANT SAFETY NOTICE

Certain Liquid Propane dealers may be filling liquid propane cylinders for use in the grill beyond cylinder filling capacity. **This "overfilling" may create a dangerous condition.** "Overfilled" tanks can build up excess pressure as a safety device. The tanks pressure relief valve will vent propane gas vapor to relieve this excess pressure. This vapor is combustible and therefore can be ignited.

To reduce this danger, you should take the following safety precautions:

1. When you have your tank filled, be sure you tell the supplier to fill it to no more than  $3\frac{1}{4}$  (75%) of its total capacity.
2. If you own or use an extra spare tank, or have a disconnected tank, you should **NEVER** store it near or under the grill unit or heat box, or near any other ignition or heat source.

A metallic sticker with this warning is attached to the grill to remind you, your family and all others who may use your BBQ grill of these safety precautions.

**Do not remove this sticker.**

 **DANGER**



**NEVER** store a spare LP cylinder under or near this unit.

**NEVER** fill the tank beyond  $3/4$  full.

**A fire causing death or serious injury may occur.**

P/N 17147

## TABLE OF CONTENTS

<b>SECTION ONE:</b> General Safety Instructions .....	2
<b>SECTION TWO:</b> Gas Requirements.....	4
<b>SECTION THREE:</b> Locating the Professional Grill .....	6
<b>SECTION FOUR:</b> Built-In Installation.....	7
<b>SECTION FIVE:</b> Leak Testing .....	8
<b>SECTION SIX:</b> Adjustments and Efficiency.....	9
<b>SECTION SEVEN:</b> Installer Final Checklist .....	10
<b>SECTION EIGHT:</b> Description.....	11
<b>SECTION NINE:</b> Using the Grill .....	12
<b>SECTION TEN:</b> Lighting Instructions.....	23
<b>SECTION ELEVEN:</b> Care and Maintenance .....	25
<b>SECTION TWELVE:</b> Burner Removal and Cleaning .....	26
<b>SECTION THIRTEEN:</b> Igniter Replacement .....	28
<b>SECTION FOURTEEN:</b> Trouble Shooting.....	28
<b>SECTION FIFTEEN:</b> Professional Grill Parts Lists.....	30
<b>SECTION SIXTEEN:</b> Warranty Information .....	34

▲ **PLEASE RETAIN THIS MANUAL FOR FUTURE REFERENCE.**

▲ **THIS OUTDOOR COOKING GAS APPLIANCE IS NOT INTENDED TO BE INSTALLED IN OR ON RECREATIONAL VEHICLES AND/OR BOATS.**

### FOR YOUR SAFETY

If you smell gas:

1. Shut off gas to the appliance.
2. Extinguish any open flames.
3. Open lid.
4. If odor continues, immediately call your gas supplier.



### WARNING

Do not try lighting this appliance without reading the "LIGHTING INSTRUCTIONS" section of this manual.

### FOR YOUR SAFETY

Do Not store or use gasoline or other flammable vapors and liquids in the vicinity of this or any other appliance.

**TESTED IN ACCORDANCE WITH ANSI Z21.58a-1991 STANDARD FOR OUTDOOR COOKING GAS APPLIANCES. THIS GRILL IS FOR OUTDOOR USE ONLY.**

Check your local building codes for the proper method of installation. In the absence of local codes, this unit should be installed in accordance with the National Fuel Gas Code No. Z223.1-1988 and the National Electrical Code ANSI/NFPA No. 70-1990.

### CALIFORNIA PROPOSITION 65 - WARNING

The Burning of gas cooking fuel generates some by products which are on the list of substances which are known by the State of California to cause cancer or reproductive harm. California law requires businesses to warn customers of potential exposure to such substances. To minimize exposure to these substances, always operate this unit according to the use and care manual, ensuring you provide good ventilation when cooking with gas.

## SAFETY PRACTICES TO AVOID PERSONAL INJURY

When properly cared for, your Professional Grill will give safe, reliable service for many years. However, extreme care must be used since the grill produces intense heat and can increase accident potential. When using this appliance basic safety practices must be followed, including the following:

Read this Care and Use Manual carefully and completely before using your grill to reduce the risk of fire, burn hazard or other injury.

Begin by ensuring proper installation and servicing (see Sections Two through Seven).

Do not repair or replace any part of the grill unless specifically recommended in this manual. All other service should be referred to a qualified technician.

**⚠ Children should not be left alone or unattended in an area where the grill is being used. Never allow them to sit, stand or play on or around the grill at any time. When in use, portions of the grill get hot enough to cause severe burns.** Do not store items of interest to children around or below the grill, in the cart or masonry enclosure. Never allow children to crawl inside a cart or enclosure.

Never let clothing, pot holders or other flammable materials come in contact with or too close to any grate, burner or hot surface until it has

cooled. Fabric may ignite and result in personal injury.

Begin by insuring proper installation and servicing. Follow the installation instructions provided with this product. Have your grill installed by a qualified technician. Have the installer show you where the gas supply shut off valve is located so that you know where to shut off the gas to the grill. If you smell gas, your installer has not done a proper job of checking for leaks. If the connections are not perfectly seated and tightened, you can have a small leak and therefore a faint gas smell. Finding a leak is not a "do-it-yourself" procedure. Some leaks can only be found with the burner control in the on position and this must be done by a qualified technician.

For personal safety, wear proper apparel. Loose fitting garments or sleeves should never be worn while using this appliance. Some synthetic fabrics are highly flammable and should not be worn while cooking.

Only certain types of glass, heat-proof glass ceramic, earthenware, or other glazed utensils are suitable for grill use. Use of these types of materials may break with sudden temperature changes. Use only on low or medium heat settings according to the manufacturer's directions.

Do not heat unopened food containers as a build-up of pressure may

cause the container to burst.

Use a covered hand when opening the grill lid and only do so slowly to allow heat and steam to escape. Never lean over an open grill.

**When lighting a burner, always pay close attention to what you are doing. Be certain you are rotating the igniter labeled for the burner you intend on using.**

When using the grill: do not touch the grill rack, burner grate or immediate surrounding area as these areas become extremely hot and could cause burns. Keep children away!

Use only dry potholders; moist or damp potholders on hot surfaces may cause burns from steam. Do not use a towel or bulky cloth in place of potholders. Do not let potholders touch hot portions of the grill rack or burner grate.

Grease is flammable. Let hot grease cool before attempting to handle it. Avoid letting grease deposits collect in the drip pan. Clean often.

Do not use aluminum foil to line drip pans or grill racks. This can severely upset combustion air flow or trap excessive heat in the control area. The result of this can be melted knobs or rotary igniters.

When using the open top burners always use flat bottomed utensils

which are large enough to cover the burner. Adjust the flame so that it heats only the bottom of the pan to avoid ignition of clothing. Position handles inward away from open edges of the unit to avoid burns associated with unintentional spillovers. Hold the handle of the pan to prevent movement of the utensil when turning or stirring food.

For proper lighting and performance of the burners keep the ports clean. It is necessary to clean them periodically for optimum performance. See Section Eleven.

Clean the grill with caution. Avoid steam burns; do not use a wet sponge or cloth to clean the grill while it is hot. Some cleaners produce noxious fumes or can ignite if applied to a hot surface.

**!** Insect Warning!!! Spiders and insects can nest in the burners of this and any other grill, and cause the gas to flow from the front of the burner. This is a very dangerous condition which can cause a fire to occur behind the valve panel, thereby damaging the grill and making it unsafe to operate. Inspect the grill twice a year or immediately if any of the symptoms in Section 13 exist.

Be sure all grill controls are turned off and the grill is cool before using any type of aerosol cleaner on or around the grill. The chemical that produces the spraying action could, in the presence of heat, ignite or cause metal parts to corrode.

Do not use the grill for cooking excessively fatty meats or products which promote flare-ups.

Never grill without the drip pan in place and pushed all the way to the back of the grill. Without it hot grease could leak downward and produce a fire or explosion hazard.

Do not operate the grill under unprotected combustible construction. Use only in well ventilated areas. Do not use in buildings, garages, sheds, breezeways or other such enclosed areas. This unit is for outdoor use only.

The grill vents combustion gases and smoke to the back of the appliance. Do not locate the grill where the grill exhaust is directed at combustible materials, windows (open or closed), doorways, etc.

Keep the area surrounding the grill free from combustible materials, trash, or combustible fluids and vapors such as gasoline or charcoal lighter fluid. Do not obstruct the flow of combustion and ventilation air.

If a cart unit is stored indoors ensure that it is cool before attempting to move the grill. First shut off and remove the LP cylinder and store outside. From the caster side of the grill push, never pull, the grill. If LP, the cylinder must be unhooked and the LP cylinder stored outside in a well ventilated area, out of reach of

children.

Do not use charcoal in the grill.

Never use the grill in a windy area.

Keep any electrical supply cord, or the rotisserie motor cord away from the heated areas of the grill.

Never use the grill in windy conditions. If located in a consistently windy area (oceanfront, mountain-top, etc.) a wind break will be required. Always adhere to the specified clearances listed in Section Three.

**Never use a dented or rusty LP tank. See the requirements in Section Two.** Never put more than one LP cylinder below a cart-mounted grill. Never modify the grill cart to house a larger cylinder or more than one cylinder at a time.

The Professional Grill is designed for a single layer of lava rock to be spread evenly over the stainless steel radiant above the grill burners. Do not use more than a single layer to avoid blocking off the area for the grill burners to vent. Adding excess rock can damage ignition components and knobs, and void the warranty.

Keep the ventilation openings of the cylinder enclosure free and clear from debris.

## GAS REQUIREMENTS

Verify the type of gas supply to be used, either natural or L.P., and make sure the marking on the grill rating plate agrees with that of the supply. The rating plate is located on the inside back wall of the Professional Grill. An "X" will be marked next to the type of gas that the unit is orificed for.

Never connect an unregulated gas line to the appliance.

An installer supplied gas shut-off valve must be installed in an easily accessible location. All installer supplied parts must conform to local codes, or in the absence of local codes, with the National Electrical Code, ANSI/NFPA 70-1990, and the National Fuel Gas Code, ANSI Z223.1-1988.

All pipe sealants must be an approved type and resistant to the actions of L.P. gases. Never use pipe sealant on flare fittings. All gas connections should be made by a competent technician and in accordance with local codes and ordinances. In the absence of local codes, the installation must comply with the national fuel gas code ANSI Z223.1-1988.

Gas conversion kits are available from the factory. They are only to be installed by experienced and licensed gas technicians familiar with gas appliances and their necessary adjustments. When ordering have the model number, and the type of gas (natural or L.P.) which you need the Professional Grill orificed for available.

Total gas consumption of the Professional Grill with all burners on "HI":

48ABQRS.....	109,000 BTU
48ABQARS.....	113,000 BTU
48ABQS.....	95,000 BTU
48ABQAS.....	85,000 BTU
36ABQRS.....	88,500 BTU
36ABQARS.....	79,000 BTU

36ABQS.....	75,000 BTU
36ABQAS.....	65,000 BTU
27ABQR.....	54,000 BTU
27ABQ.....	40,000 BTU
131.....	15,000 BTU
132.....	30,000 BTU

The appliance and its individual shut off valve must be disconnected from the gas supply piping system during any pressure testing of that system at test pressures in excess of 1/2 PSIG (3.5 kPa.)

The appliance must be isolated from the gas supply piping system by closing its individual manual shut-off valve during any pressure testing of the gas supply piping system at test pressures equal to or less than 1/2 PSIG (3.5 kPa.)

The installation of this appliance must conform with local codes or, in the absence of local codes, with the national fuel gas code, ANSI Z223.1a-1988. Installation in Canada must be in accordance with the

Standard Can1-b149.1 and/or .2 (installation code for gas burning appliances and equipment) and local codes.

### NATURAL GAS HOOK UP

Connection: 1/2" NPT male with 3/8 flare adapter.

Operating pressure: 4.0" W.C.

Supply pressure: 5" to 14" water column. If in excess of 14" W.C. a step down regulator is required.

Check with your local gas utility company or with local codes for instructions on installing gas supply lines. Be sure to check on type and size of run, and how deep to bury the line. If the gas line is too small, the Professional Grill will not function properly.

Any joint sealant used must be an approved type and be resistive to the actions of L.P. gases.

Figure 4-1 Natural Gas (Valve panel typical of 36ABQR shown)

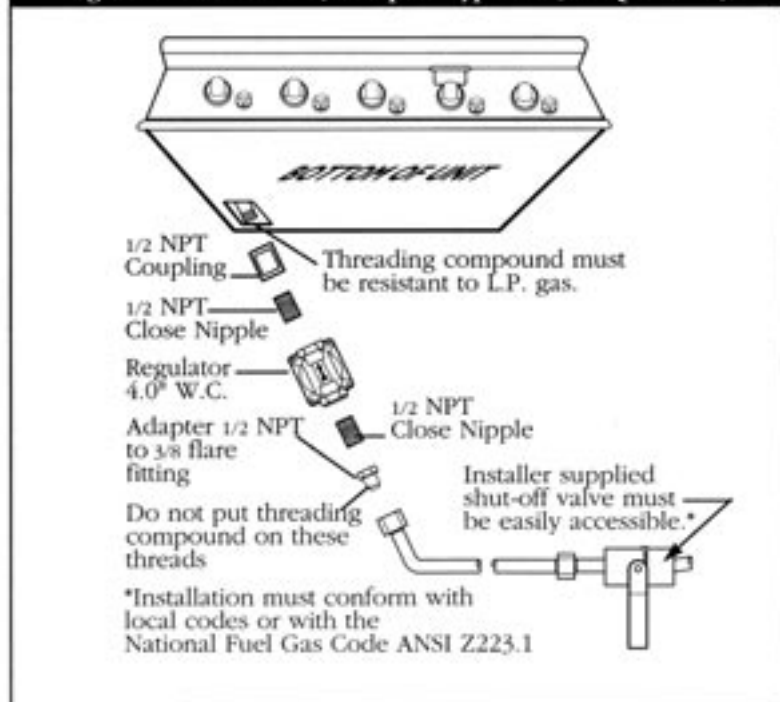

To hook-up the fittings supplied with the Professional Grill:

Assemble as shown. Use threading compound on male threads only. Do not use threading compound on the male end of the 1/2 NPT to 3/8 flare adapter. Use a second pipe wrench to hold the grill inlet pipe to avoid shifting any internal gas lines of the grill.

Ensure that the regulator arrow points in the direction of gas flow—towards the unit, away from the supply.

Do not forget to place the installer supplied gas valve in an accessible location.

### L.P. GAS HOOK UP

Professional Grills orificed for use with L.P. gas come equipped with a high capacity hose/regulator assembly for connection to a standard 20 lb. L.P. cylinder (5LP-A quick disconnect). The L.P. tank is not included.

Connection: 1/2" NPT male with a 3/8" flare adapter (included).

Operating pressure: 10.0" W.C.

To connect the L.P. regulator/hose assembly to the tank/valve assembly, first make sure the main valve on the tank is completely closed. Although the flow of gas is stopped when the 5LP-A system is disconnected as part of its safety feature, you should always turn the L.P. tank main valve (Fig. 5-1) off after each use and during transport of the tank or unit.

Pull back the coupler sleeve towards the main knob and insert the fitting into the coupler (Fig. 5-1), release the sleeve and continue pushing the inlet into the coupler until the sleeve snaps forward securing the connection.

Turn the main tank valve on and turn the burner control valves on the unit to the "lite" position for about 20 seconds to allow the air in the system to purge before attempting to

light the burners.

To disconnect the coupler, first make sure the main tank valve is turned off. Grasp the coupler sleeve and pull back towards the main valve. The inlet will then disengage itself. Remove the inlet from the coupler opening if it has not already done so when it disengaged.

Your local L.P. filling station should be equipped with the proper equipment to fill your tank, however, should you find an adapter becomes necessary, you can purchase one at your local retailer. The item to purchase is a #5LP-A-FP plug adapter (see Fig. 5-1)

### L.P. TANK REQUIREMENTS

A dented or rusty L.P. tank may be hazardous and should be checked by your L.P. supplier. Never use a cylinder with a damaged valve.

The L.P. gas cylinder must be constructed and marked in accordance with the specifications for L.P. gas cylinders of the U.S. Department of Transportation (DOT) and designed for use with a 5LP-A quick disconnect system only. Do not change the regulator/hose assembly from that supplied with the unit or attempt to use a 5LP-A equipped regulator/hose assembly with a standard 510 POL tank/valve assembly.

The cylinder must be provided with a shut off valve terminating in an L.P. gas supply cylinder valve outlet specified, as applicable, for connection No. 5LP-A.

If the appliance is stored indoors the cylinder must be disconnected and removed from the appliance.

Cylinders must be stored outdoors in a well-ventilated area out of the reach of children.

Figure 5-1 L.P. Gas (Valve panel typical of 36BQR shown)

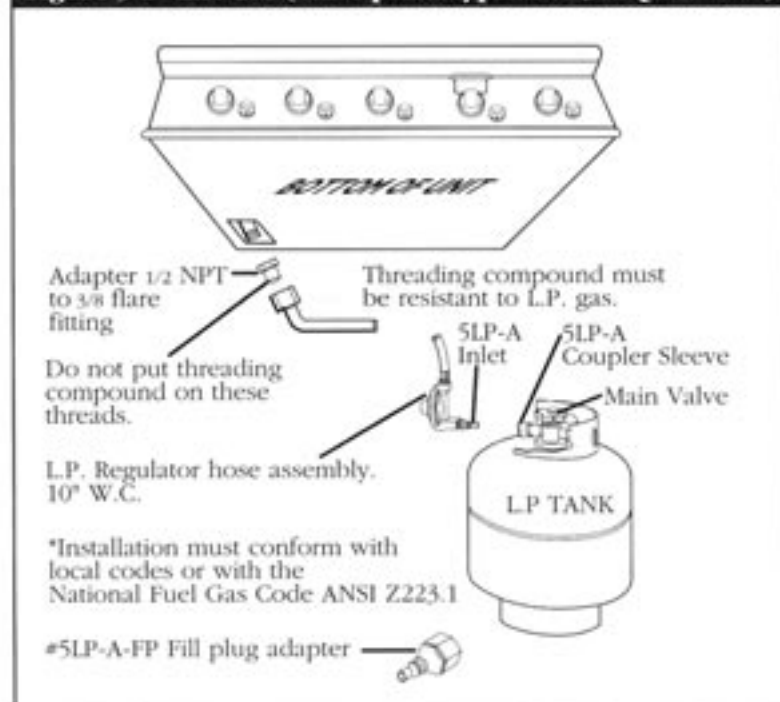

**ALWAYS CHECK FOR  
LEAKS AFTER EVERY  
L.P. TANK CHANGE.  
See Section Five.**

Figure 6-1 48"/36" GRILL MODELS

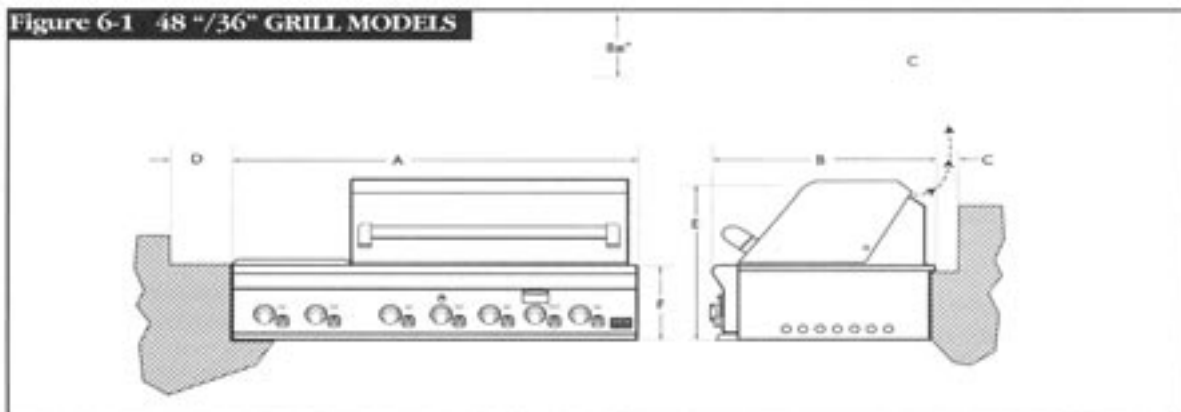
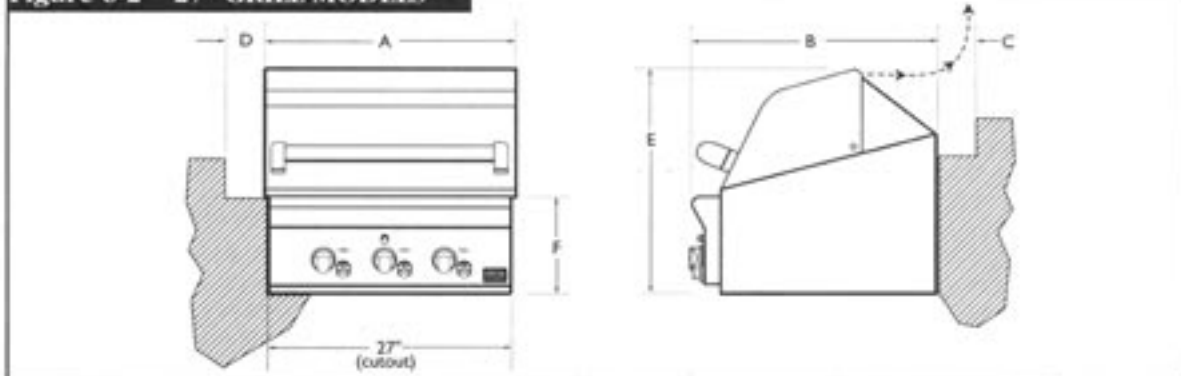

Figure 6-2 27" GRILL MODELS



GRILL MODEL	A	B	C (to combustible construction)	C (to non-combustible construction/clearance)	D (L/R)	E	F
48A BQAXRXS)	47 <sup>3</sup> / <sub>8</sub> "	26 <sup>1</sup> / <sub>2</sub> "	12"	3"	12"	22 <sup>3</sup> / <sub>8</sub> "	9 <sup>1</sup> / <sub>2</sub> "
36A BQAXRXS)	35 <sup>3</sup> / <sub>8</sub> "	26 <sup>1</sup> / <sub>2</sub> "	12"	3"	12"	22 <sup>3</sup> / <sub>8</sub> "	9 <sup>1</sup> / <sub>2</sub> "
27A BQXR)	27 <sup>3</sup> / <sub>4</sub> "	26 <sup>1</sup> / <sub>4</sub> "	12"	3"	6"	24 <sup>3</sup> / <sub>8</sub> "	10 <sup>1</sup> / <sub>2</sub> "

**CLEARANCE***(To Combustible Construction)*

A Minimum of 12" from the sides and a minimum of 12" from the back must be maintained from the Professional Grill above and below the cooking surface to adjacent vertical combustible construction.

**CLEARANCE***(To Non-Combustible Construction)*

A minimum of 3" clearance from the back of the grill to non-combustible construction is required for the purpose of allowing the lid to open fully. It is desirable to allow at least

6" side clearance to non-combustible construction above the cooking surface for counter space. If you'll be using the rotisserie option, the space is essential for motor and skewer clearance. The Professional Grill can be placed directly adjacent to non-combustible construction below the cooking surface.

**INSULATED JACKET**

Do not build the Professional Grill under overhead unprotected combustible construction. If the Professional Grill is to be placed into a combustible enclosure, an approved insulated jacket is necessary and is available from your deal-

er. Use only the Dynamic Cooking Systems insulated jacket which has specifically been designed and tested for this purpose.

**LOCATION**

When determining a suitable location take into account concerns such as exposure to wind, proximity to traffic paths and keeping any gas supply lines as short as possible. Locate the grill only in a well ventilated area. Never locate the grill in a building, garage, breezeway, shed or other such enclosed areas without an approved ventilation system. During heavy use, the grill will produce a lot of smoke. Ensure there is adequate area for it to dissipate.

# BUILT-IN INSTALLATION

## GENERAL - (48"/36" Models)

The Professional Grill is designed for easy placement into masonry enclosures. For non-combustible applications the grill drops into the opening shown in Figure 7-1 and hangs from its side flanges. A deck is not required to support it from the bottom. When using the insulated jacket in a combustible enclosure application, see Figure 7-2. The jacket assembly must be supported from the bottom by a ledge on each side or a solid deck beneath the entire grill or insulated jacket.

## GENERAL - (27" Models only)

The Professional Grill is designed for easy placement into masonry enclosures. For non-combustible applica-

tions the grill drops into the opening shown in Figure 7-3. A deck or ledge is required to support it from the bottom. When using the insulated jacket in a combustible enclosure application, see Figure 7-4. The jacket assembly must be supported from the bottom by a ledge on each side or a solid deck beneath the entire grill or insulated jacket.

**ALL GRILL MODELS**-Review the detail drawings below and take into account the provisions shown for gas line hook-up clearance in the left rear corner.

It is recommended that ventilation holes are provided in the enclosure in the event of a gas leak. The supporting ledges or deck must be level and flat. The counter should also be level.

## NOTE A:

### MASONRY OPENING DETAILS

#### 48"/36" Models Only:

\*If using a backsplash apron or rear wall, locate electrical service on the right hand side for rotis motor use.

#### 27" Models Only:

\*If using a backsplash apron or rear wall, locate electrical service on the left hand side for rotis motor use.

### IMPORTANT

Gas fittings, regulator, and installer supplied shut-off valves must be easily accessible.  
See Section 2.

Figure 7-1 48"/36" Grill Models - Standard

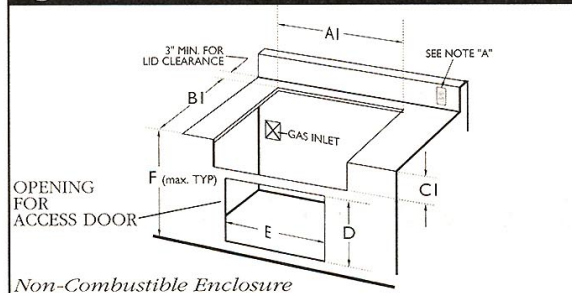

Figure 7-2 48"/36" Models - Insulated Jacket

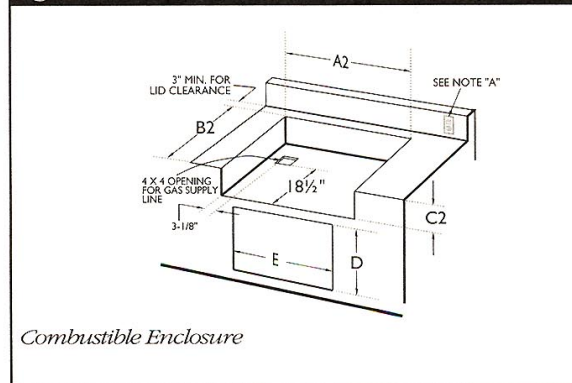

Figure 7-3 27" Grill Models - Standard

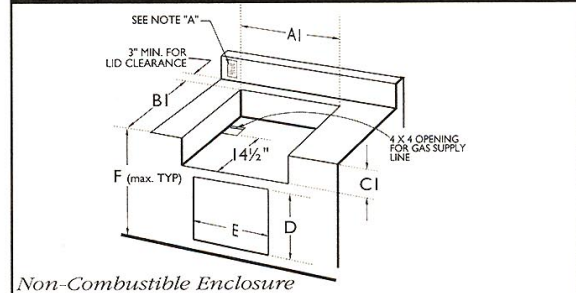
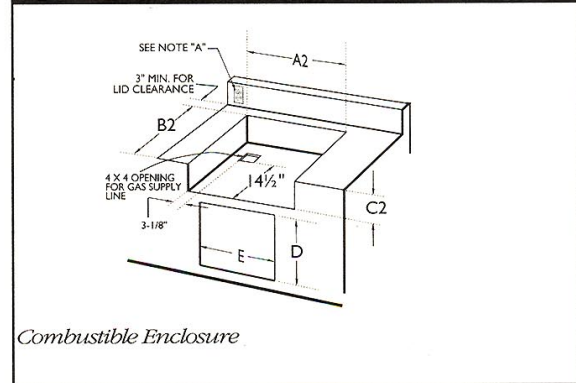

Figure 7-4 27" Models - Insulated Jacket



GRILL MODEL	A1	A2	B1	B2	C1	C2	D	E	F
48A BQ...	45 1/2"	51 5/8"	22 3/4"	23 3/4"	9 1/8"	10 1/8"	18 3/8"	24 3/8"	35 1/2"
36A BQ...	34 3/8"	40 1/2"	22 3/4"	23 3/4"	9 1/8"	10 1/8"	18 3/8"	24 3/8"	35 1/2"
27A BQ...	27 3/8"	33 3/8"	23"	24"	10 1/2"	11 1/2"	18 3/8"	24 3/8"	35 1/2"

## LEAK TESTING

Figure 8-1 Natural Gas (36" Model shown)

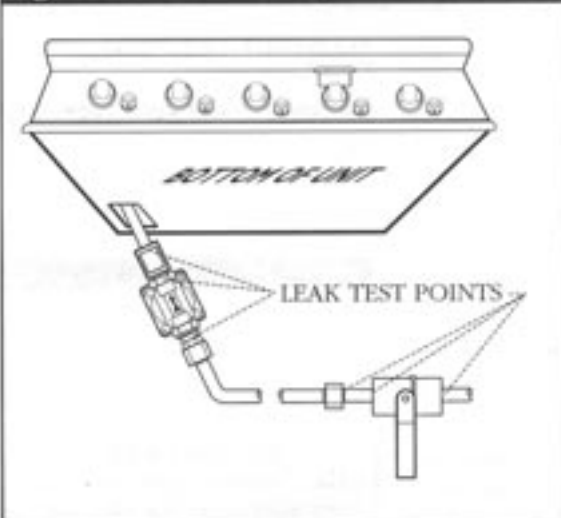
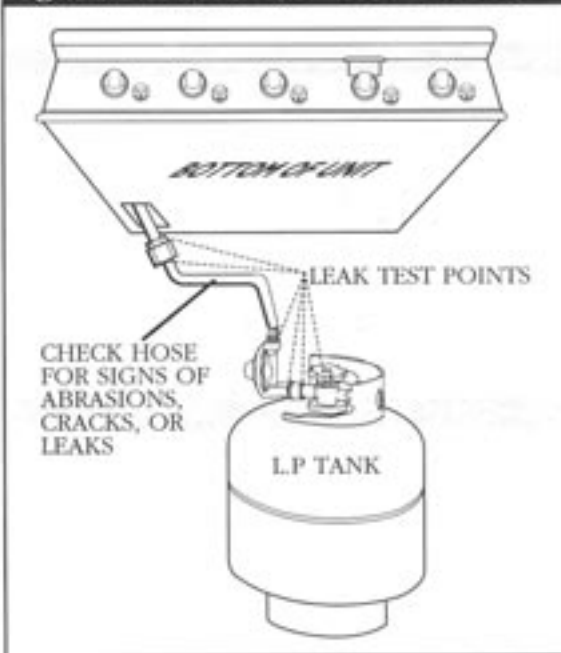

Figure 8-2 L.P. Gas (36" Model shown)



- Check all gas supply fittings for leaks before each use. It is handy to keep a spray bottle of soapy water near the shut-off valve of the gas supply valve. Spray all the fittings. Bubbles indicate leaks.

**GENERAL**

Although all gas connections on the Professional Grill are leak tested at the factory prior to shipment, a complete gas tightness check must be performed at the installation site due to possible mishandling in shipment, or excessive pressure unknowingly being applied to the unit. Periodically check the whole system for leaks, or immediately check if the smell of gas is detected.

**BEFORE TESTING**

Do not smoke while leak testing. Extinguish all open flames.

Never leak test with an open flame.

Make a soap solution of one part liquid detergent and one part water. You will need a spray bottle, brush, or rag to apply the solution to the fittings. For L.P. units, check with a full cylinder.

**VALVE PANEL REMOVAL**

The valve panel must be removed to check the valves and fittings. Remove the knobs. If you have a rotis burner remove the safety valve pushbutton and unscrew the surrounding bezel. Then remove the 4 screws which fasten the valve panel to the unit. Pull the valve panel outward and unplug the wires from the back of the rotary igniters. If your grill has the optional rotis burner, remove the screws which hold the inspection cover in place (Section 8, Item 11).

**TO TEST**

Make sure all control valves are in the "off" position. Turn the gas supply "on". Check all connections from the supply line, or L.P. cylinder up to and including the manifold pipe assembly. Apply the soap solution around the connection, valve and tubing. Soap bubbles will appear where a leak is present. If a leak is present, immediately turn off gas supply, tighten any leaking fittings, turn gas on, and recheck.

Check all the gas connections at the base of the control valves where they screw into the manifold pipe.

To check rotis burner and safety valve the burner must be lit (see Section 10), then leak test the connections located under the safety cover.

If you cannot stop a gas leak immediately turn off the gas supply and call your local gas utility, or the dealer you purchased the appliance from. Only those parts recommended by the manufacturer should be used on the Professional Grill. Substitution can void the warranty.

Do not use the Professional Grill until all connections have been checked and do not leak.

## Burner air adjustment:

**Figure 9-1 Grill Burner Flame Height**

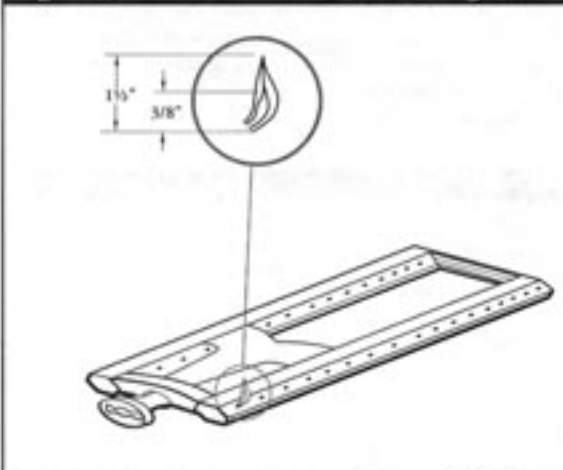

**Figure 9-2 Power Burner Flame Height**

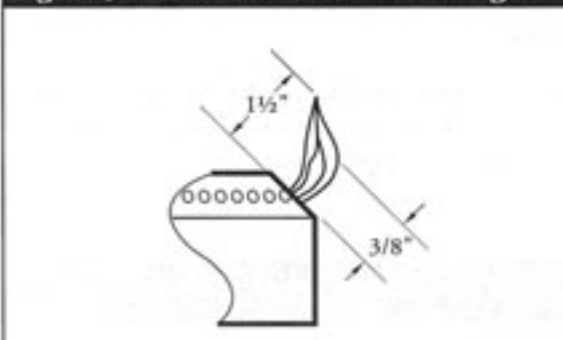

**Figure 9-3 Power Burner Air Shuttters**

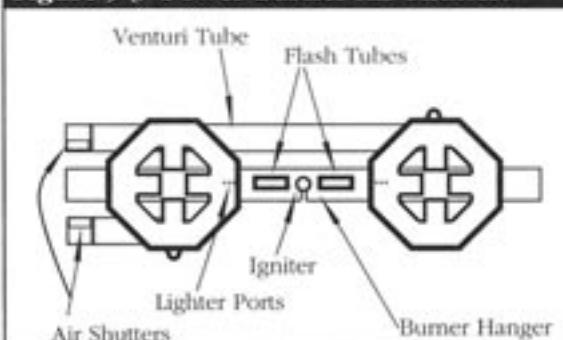

Each grill burner is tested and adjusted at the factory prior to shipment; however, variations in the local gas supply or a conversion from one gas to another may make it necessary to adjust the burners. The flames of the burners (except the rotisserie burner) should be visually checked and compared to that of the drawing in Fig. 9-1 and Fig. 9-2.

Flames should be blue and stable with no yellow tips, excessive noise or lifting. If any of these conditions exist, check if the air shutter or burner ports are blocked by dirt, debris, spider webs, etc. Proceed with air shutter adjustment.

The amount of air which is entrained into a burner is governed by a sheet metal cup or disk at the inlet of the burner called an air shutter. It is locked in place by a set screw which must be loosened prior to lighting the burner for adjustment.

To access the grill burner air shutters first remove the valve panel. See Valve Panel Removal on previous page. With a screw driver, loosen the lock-screw on the face of the air shutter. Light the burner and adjust according to the directions below.

Access for the power burner air shutters is through the top after removing the top burner grate (See Fig. 9-3).

### TO ADJUST:

Be careful as the burner may be very hot.

If the flame is yellow, indicating insufficient air, turn the air shutter counter-clockwise to allow more air to the burner.

If the flame is noisy and tends to lift away from the burner, indicating too much air, turn the air shutter clockwise.

Once adjusted turn the burner off and reverse steps to reassemble.

## Low setting adjustment:

Figure 10-1 Low Setting Adjustment

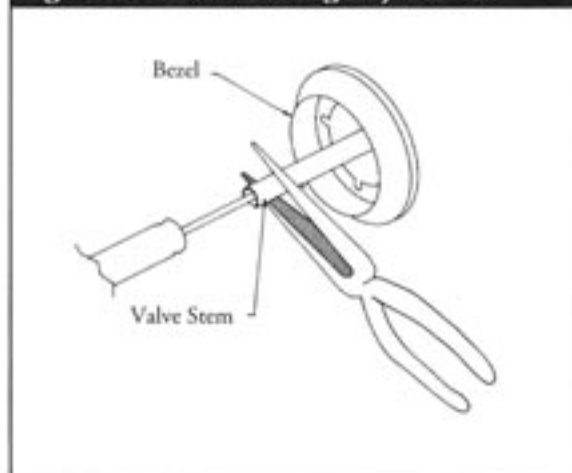

The valves on the professional grill feature an adjustable low setting. Due to fluctuations in gas pressure, heating value or gas conversion, you may feel it necessary to increase or decrease to gas flow in the low position. We do not recommend adjusting the infra-red rotis burner.

### TO ADJUST:

1. Light the burner.
2. Turn the control knob to the lowest setting (all the way counter-clockwise).
3. Remove the knob.
4. While holding the valve shaft with pliers, insert a thin, flat tipped screwdriver into the shaft and while viewing the burner adjust to a minimum stable flame (Figure 10-1).

### ! WARNING

Always verify the low rate flame size for stability. A burner flame which is too small may go out or be extinguished easily. This can cause unburned gas to escape and cause a hazardous condition. ALWAYS VERIFY THE LOW RATE!

## INSTALLER FINAL CHECKLIST

- |  |  |  |
|--|--|--|
| <ul style="list-style-type: none"> <li><input type="checkbox"/> Specified clearances maintained to combustibles. Grill vents to open air area, away from windows, doors, and confined spaces.</li> <li><input type="checkbox"/> Nylon straps removed from burners.</li> <li><input type="checkbox"/> All internal packaging removed. All protective plastic removed from stainless steel. Check all internal parts and inside the lid.</li> <li><input type="checkbox"/> Knobs turn freely, bezels centered.</li> <li><input type="checkbox"/> Each burner lights satisfactorily,</li> </ul> | <ul style="list-style-type: none"> <li>individually or with adjacent burner lit.</li> <li><input type="checkbox"/> Air shutters adjusted.</li> <li><input type="checkbox"/> Adjustable low setting satisfactory.</li> <li><input type="checkbox"/> Drip pan in place properly and sliding freely. (No debris under grill.)</li> <li><input type="checkbox"/> Pressure regulator connected and set for 4.0" W.C. Natural, 11.2" W.C. L.P. gas.</li> <li><input type="checkbox"/> Manual shut off valve installed and accessible.</li> </ul> | <ul style="list-style-type: none"> <li><input type="checkbox"/> Unit tested and free of leaks.</li> <li><input type="checkbox"/> Lava rock evenly distributed over lava radiant.</li> <li><input type="checkbox"/> User informed of gas supply shut off valve location.</li> </ul> <p><b>• PLEASE LEAVE THESE INSTRUCTIONS WITH THE USER.</b></p> <p><b>• USER, PLEASE RETAIN THESE INSTRUCTIONS FOR FUTURE REFERENCE. If grill or house-hold of built-in grill changes ownership, please forward these instructions to the new owner.</b></p> |
|--|--|--|

## FEATURE IDENTIFICATION

**Figure 11-1 MODEL DCS48A-BQRS (shown below)**

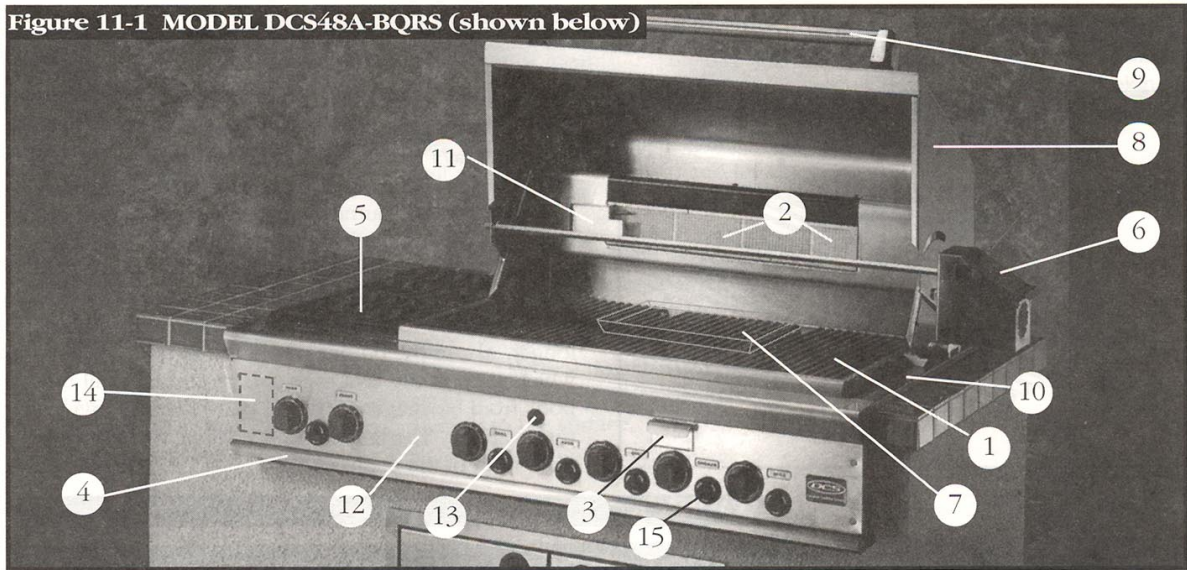

- |   |  |  |
|---|--|--|
| <p><b>1.</b> Grill Section;<br/>3 sections as shown on<br/>DCS 48A BQ and 36A BQA<br/>Series,<br/>2 sections on the DCS36A BQ<br/>4 sections on DCS 48A BQA</p> | <p><b>3.</b> Smoker system<br/>(All 48" / 36" Models Only)</p> | <p><b>10.</b> Support flange / trim</p>  |
| <p><b>2.</b> Infra-red rotis burner<br/>(optional)</p>  | <p><b>4.</b> Drip Tray</p>                                     | <p><b>11.</b> Rotis electrode cover</p>  |
| <p><b>5.</b> Range top power burners<br/>(Not available on BQA series)</p>  | <p><b>6.</b> Rotis motor assembly</p>                          | <p><b>12.</b> Valve panel</p>  |
| <p><b>7.</b> Rotis basting pan</p>  | <p><b>8.</b> Roll top lid</p>                                  | <p><b>13.</b> Safety valve button<br/>(units equipped with optional<br/>rotis burner only)</p> |
| <p><b>9.</b> Handle</p>   | <p><b>14.</b> Lighting instructions</p>                        | <p><b>15.</b> Rotary igniter</p>   |

- |  |  |
|--|--|
| <p><b>1.</b> Grill Section;<br/>DCS27BQR</p>           | <p><b>11.</b> Valve panel</p>  |
| <p><b>2.</b> Infra-red rotis<br/>burner (optional)</p> | <p><b>12.</b> Safety valve button<br/>(units equipped<br/>with<br/>optional rotis burn-<br/>er only)</p> |
| <p><b>3.</b> Smoker Tray</p>                           | <p><b>13.</b> Lighting instruc-<br/>tions</p>  |
| <p><b>4.</b> Drip tray</p>                             | <p><b>14.</b> Rotary Igniter</p>   |
| <p><b>5.</b> Rotis motor assem-<br/>bly</p>            |  |
| <p><b>6.</b> Rotis basting pan</p>                     |  |
| <p><b>7.</b> Roll top lid</p>                          |  |
| <p><b>8.</b> Handle</p>                                |  |
| <p><b>9.</b> Support flange/trim<br/>(optional)</p>    |  |
| <p><b>10.</b> Rotis electrode<br/>cover</p>            |  |

**Figure 11-2 MODEL DCS27A-BQR**

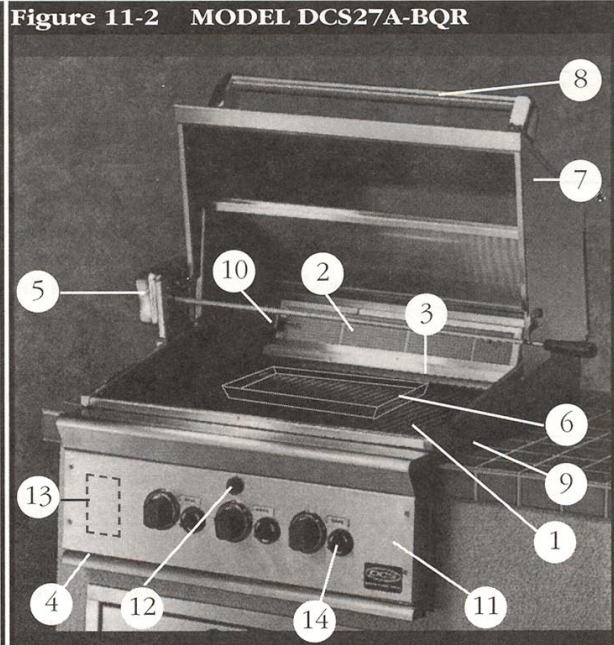

## The Grill

**Figure 12-1 Porcelain Enameled Cooking Rack**

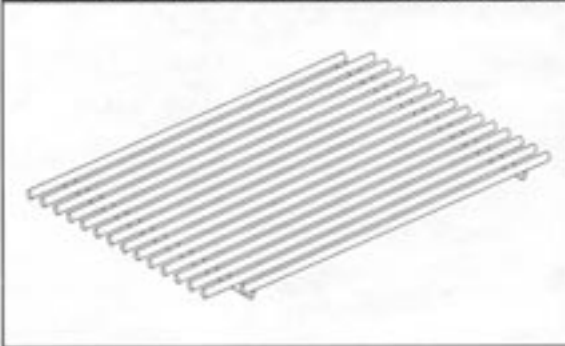

**NOTE:**

The hot grill sears the food, sealing in the juices. The longer the preheat, the faster the meat browns and the darker the grill marks.

**LAVA ROCK:**

The Professional Grill is supplied with natural lava rock. Because of the porosity of natural lava rock it is superior in its ability to capture heat as it rises from the grill burners. They also possess the thermal mass needed for professional results. Flare ups are controlled because our lava radiant keeps grease from getting to the flames and igniting. The intense heat produced by this system produces true grilled flavor as fats and juices are brought to the surface of the food and caramelized.

Place lava rocks in a single layer on top of the radiant located under the grill rack. It is important to distribute the rocks evenly over the grate without leaving any large gaps. Uneven distribution of rocks and air gaps can cause localized "hot" and "cold" spots which could result in unsatisfactory cooking performance.

**DO NOT** leave the grill unattended while cooking.

**USING THE GRILL:**

Grilling requires high heat for searing and proper browning. Most foods are cooked at the "HI" heat setting for the entire cooking time. However, when grilling large pieces of meat or poultry, it may be necessary to turn the heat to a lower setting after the initial browning. This cooks the food through without burning the outside. Foods cooked for a long time or basted with a sugary marinade may need a lower heat setting near the end of the cooking time.

1. Check to be certain the drip tray is in place.
2. Light the grill burners using the instructions in Section 10.
3. Turn the control knob to "HI" and preheat the grill for 15 minutes. The top cover is to be closed during the appliance preheat period.
4. Place the food on the grill and cook to the desired doneness. Adjust heat setting, if necessary. The control knob may be set to any position.

The doneness of meat, whether rare, medium, or well done, is affected to a large degree by the thickness of the cut. Expert chefs say it is impossible to have a rare doneness with a thin cut of meat.

The cooking time is affected by the kind of meat, the size and shape of the cut, the temperature of the meat when cooking begins, and the degree of doneness desired.

When defrosting meats it is recommended that it be done overnight in the refrigerator as opposed to a

microwave. This in general yields a juicier cut of meat.

Use a spatula instead of tongs or a fork to turn the meat, as a spatula will not puncture the meat and let the juices run out.

To get the juiciest meats, add seasoning or salt after the cooking is finished and turn the meat only once (juices are lost when the meat is turned several times). Turn the meat just after the juices begin to bubble to the surface.

Trim any excess fat from the meat before cooking. To prevent steaks or chops from curling during cooking, slit the fat around the edges at 2-inch intervals.

**! DO NOT leave the grill unattended while cooking.**

Always ensure that the meat is thoroughly cooked by using a meat thermometer.

FOOD	WEIGHT OR THICKNESS	FLAME SIZE	APPROXIMATE TIME	SPECIAL INSTRUCTIONS AND TIPS
<b>VEGETABLES</b>				
<b>Fresh</b>				
Beets Carrots Turnips		Medium	12 to 20 minutes	Slice. Dot with butter or margarine. Wrap in heavy duty foil. Grill, turning occasionally.
Onion	1/2 inch slices	Medium	8 to 20 minutes	Grill, turning once. Brush occasionally with melted butter or margarine.
Potatoes Sweet	Whole	Medium	40 to 60 minutes	Wrap individually in heavy-duty foil. Grill, rotating occasionally.
White	6 to 8 ounces	High	45 to 60 minutes	
<b>Frozen</b>				
Asparagus, Broccoli, Brussel Sprouts Green Beans, Peas		Medium	15 to 30 minutes	Dot with butter or margarine. Wrap in heavy-duty foil. Grill, turning occasionally.
French Fries		Medium	15 to 30 minutes	Place in aluminum foil pan. Grill, stirring occasionally.

**GRILL COOKING CHART (cont'd)**

FOOD	WEIGHT OR THICKNESS	FLAME SIZE	APPROXIMATE TIME	SPECIAL INSTRUCTIONS AND TIPS
<b>MEATS</b> <b>Beef</b> Hamburgers	1/2 to 3/4 inch	Medium  High	10 to 18 minutes  8 to 15 minutes	Grill, turning once when juices rise to the surface. Do not leave hamburgers unattended since a flare-up could occur quickly.
Steaks Rib, Club, Tenderloin, Porterhouse, T-Bone, Sirloin				
Rare (140°)	1 inch 1-1/2 inch	High High	8 to 14 minutes 11 to 18 minutes	Remove excess fat from edge. Slash remaining fat at 2-inch intervals. Grill, turning once.
Medium (160°)	1 inch 1-1/2 inches	Medium to High	12 to 22 minutes 16 to 27 minutes	
Well-Done (170°)	1 inch 1-1/2 inches	Medium Medium	18 to 30 minutes 16 to 35 minutes	
<b>Lamb</b> Chops & Steaks				
Rare (140°)	1 inch 1-1/2 inches	High High	10 to 15 minutes 14 to 18 minutes	Remove excess fat from edge. Slash remaining fat at 2-inch intervals. Grill, turning once
Medium (160°)	1 inch 1-1/2 inches	Medium to High	13 to 20 minutes 18 to 25 minutes	
Well-Done (170°)	1 inch	Medium	17 to 30 minutes	
<b>Pork</b> Chops	1 inch 1-1/2 inches	Medium Medium	15 to 40 minutes 25 to 60 minutes	Remove excess fat from edge. Slash remaining fat at 2-inch intervals. Grill, turning once. Cook well done.
Ribs		Medium	40 to 60 minutes	Grill, turning occasionally. During last few minutes brush with barbecue sauce, turn several times.

**GRILL COOKING CHART (cont'd)**

FOOD	WEIGHT OR THICKNESS	FLAME SIZE	APPROXIMATE TIME	SPECIAL INSTRUCTIONS AND TIPS
<b>MEATS</b>				
<b>Pork</b> Ham Steaks (precooked)	1/2 inch	High	4 to 8 minutes	Remove excess fat from edge. Slash remaining fat at 2-inch intervals. Grill, turning once.
Hot Dogs		Medium	5 to 10 minutes	Slit skin. Grill, turning once.
<b>POULTRY</b>				
Broiler/Fryer Halved or Quartered	2 to 3 pounds	Low or Medium	1 to 1-1/2 hours 40 to 60 minutes	Place skin side up. Grill, turning and brushing frequently with melted butter, margarine, oil or marinade.
Breasts		Medium	30 to 45 minutes	
<b>FISH AND SEAFOOD</b>				
Steaks Halibut, Salmon, Swordfish	3/4 to 1 inch	Medium to High	8 to 15 minutes	Grill, turning once. Brush with melted butter, margarine or oil to keep moist.
Whole Catfish Rainbow Trout	4 to 8 ounces	Medium to High	12 to 20 minutes	Grill, turning once. Brush with melted butter, margarine or oil.

**BARBECUED POTATOES  
and CHEESE**

1½ Cups shredded cheddar cheese  
 1 Can (10 fl oz.) condensed cream  
 of mushroom soup  
 ½ Cup milk  
 2 Tbs. barbecue sauce  
 ¼ Tsp. oregano  
 ¼ Tsp. salt  
 ⅛ Tsp. pepper  
 4 Cups thinly sliced potatoes  
 (4 medium-sized potatoes)

Preheat grill. Combine cheese, condensed soup, milk, BBQ sauce, oregano, salt and pepper in a large mixing bowl. Stir in potatoes until well coated. Turn into well buttered 1½ quart rectangular baking dish. Cover dish with aluminum foil. Bake covered 25 minutes on medium with the lid of your BBQ grill closed. Remove foil and continue baking 15 minutes longer or until potatoes are tender. Let stand 5 minutes before serving.

**VEGETABLE KABOBS**

3 Medium-sized zucchini  
 12 Cherry tomatoes  
 12 Fresh mushrooms  
 Grated Parmesan cheese

Parboil whole zucchini 5 minutes on your side burner or until just tender. Drain and cut into ½ inch slices. Thread zucchini, tomatoes and mushrooms alternately on each of six skewers. Brush with marinade made of Italian dressing, Worcestershire sauce, mustard and thyme. Grill 5 to 7 minutes turning and basting occasionally. Sprinkle liberally with Parmesan cheese.

**FAJITAS**

1½ Lb. flank steak or  
 boned chicken breasts  
 2 Tbs. oil  
 ½ Cup lime juice  
 ½ Tsp. salt  
 ½ Tsp. celery salt  
 ¼ Tsp. garlic powder  
 ½ Tsp. pepper  
 ¼ Tsp. oregano  
 ¼ Tsp. cumin  
 Flour tortillas  
 Lemon

Pound flank steak to ¼ inch thickness or flatten chicken breasts. Mix oil, lime juice and seasonings in a ziplock bag. Add meat and shake bag to coat the meat. Refrigerate overnight or at least 6 to 8 hours. Wrap tortillas in foil. Remove meat from marinade. Cook on a pre-heated gas grill for 5 to 8 minutes on each side. While meat is cooking, heat tortillas on grill. Slice meat across grain in thin slices. Place on hot platter. Squeeze lemon juice over. Wrap meat and any of the following toppings in tortillas: chopped tomatoes, guacamole, sour cream, taco sauce.

**BARBECUED LONDON BROIL**

4 to 6 servings

¾ C. Italian dressing  
 1 Tsp. Worcestershire sauce  
 1 Tsp. dry mustard  
 ¼ Tsp. thyme, crushed  
 1 Medium onion, sliced  
 1½ Pound flank steak, scored  
 2 Tbs. butter, melted

Combine first 4 ingredients, add onion and marinate flank steak with it. Refrigerate at least 4 hours or overnight. Remove steak and grill on your preheated BBQ grill. Grill 5 to 7 minutes on each side basting frequently with the marinade. In the meantime sauté onions from the marinade in butter in a skillet on your side burner for 3 minutes. To serve, slice steak diagonally into thin slices, sprinkle onions over top. Garnish with vegetable kabobs.

**BAKED CHILI CORN**

6 Medium ears corn, husked  
 3 Tbs. butter or margarine, melted  
 Dash ground cumin  
 Dash ground coriander

About ½ hour before cooking, turn the burner on for grill. Place each corn on a heavy duty foil. In a bowl, combine remaining ingredients. Mix well. Brush 1½ Tsp. butter mixture over each ear. Close foil and fold up ends to seal. Place on grill. Cook, turning packets occasionally 10 to 12 minutes or until cooked through.

**TANGY SEAFOOD KEBABS**

- 1 Lb. large shrimp, shelled & deveined
- 3/4 Lbs. sea scallops
- 2/3 C. chili sauce
- 1/4 C. cider vinegar
- 3 Tbs. chopped parsley
- 1 Tbs. vegetable oil
- 1 Tbs. Worcestershire sauce
- 1/2 Tsp. prepared horseradish
- 1 Clove garlic, minced
- 1 20 Oz. can pineapple chunks in juice, drained

In medium bowl, combine shrimp and scallops. In small bowl combine chili sauce and next six ingredients. Pour over seafood. Toss to coat. Cover, refrigerate 2 hours.

Half hour before cooking, turn the burner to the grill on full. Drain seafood reserving marinade. On each of twelve 10" skewers, thread 2 shrimps and 2 scallops, alternating with pineapple chunks. Place skewers on grill. Cook 7-10 minutes, often basting and turning.

**BEEF AND LAMB KEBABS**

Serves 4

- 1/2 Lb. boneless sirloin or beef cut into 1" cubes
- 1/2 Lb. boneless loin of lamb cut into 1" cubes
- 2/3 C. water, divided
- 1/4 C. chopped onion
- 2 Tbs. soy sauce
- 1/4 C. vegetable oil, divided
- 1 Tbs. dark brown sugar
- 1 Tbs. fresh lemon juice
- 2 cloves garlic, minced
- 1/4 Tsp. ground cumin
- 1/4 Tsp. ground coriander
- 1/4 Tsp. ground turmeric
- 1/8 Tsp. ground red pepper
- 1/8 Tsp. ground ginger
- 1 Red pepper cut into chunks
- 1 Large banana, cut into chunks
- 8 Small mushrooms
- 1/3 C. smooth peanut butter

In blender, process 1/3 C. water, onion, soy sauce, 2 Tbsp. oil and the next 8 ingredients until smooth. Pour over meat cubes and marinate about 4 hours, turning occasionally. Drain and reserve marinade. Onto to four 12" skewers alternately thread meat, pepper, banana and mushrooms. Preheat grill. Brush the kebabs with oil. Grill 7-8 minutes each side.

Bring marinade to boil on the side burner in a saucepan. Add remaining 1/3 C. water and peanut butter. Stir to blend. Heat through. If sauce gets too thick, add 1 Tbs. water. Serve sauce with kebabs.

**BBQ SALMON**

- 2 Large salmon steaks
- 2 Tbs. oil
- Salt & pepper
- 2 Oz. thin bacon slices
- 2 Tbs. butter
- 1 Tbs. lemon juice
- Spring of parsley
- Lemon wedges

Preheat the BBQ.

Brush the steaks with oil and season with salt and pepper. Place on BBQ grill and cook for 10 minutes, turning steaks over halfway cooking time.

Meanwhile fry the bacon in a pan on the side burner. Drain on paper towels. Melt the butter in a small saucepan taking care not to discolor it. Arrange the fish and bacon on serving plates. Pour the butter over and sprinkle with lemon juice. Garnish with parsley springs and lemon wedges. Serve with boiled potatoes tossed in butter and sprinkled with chopped parsley and a crisp lettuce salad.

Note: Substitute catfish, halibut or cod for salmon.

**PORK CHOPS**

- 4 Pork chops
- Marinade
- 1 Large onion
- 2 Tbs. Lemon juice or vinegar
- 2 Tbs. Oil
- 1/2 Tsp. Powdered mustard
- 2 Tsp. Worcestershire sauce
- 1/2 Tsp. Freshly ground black pepper
- 1 Tsp. Sugar
- 1/2 Tsp. Paprika
- 1 Clove garlic

Peel, grate onion, add rest of the ingredients except the pork chops. Mix well. Pour over chops and marinate one hour in a cool place. Turn the BBQ grill on full. Heat 10 minutes. BBQ the chops brushing with the marinade occasionally. Serve with mixed salad, dressed with vinaigrette flavored with fresh dill.

**EGGPLANT CAVIAR**

- 1 Large eggplant
- 2 Tbs. Olive oil
- 2 Tbs. wine vinegar
- 2 Tbs. finely chopped onion
- 1/2 Clove garlic, minced
- 1 Medium tomato, chopped
- Salt and Pepper

Roast eggplant on gas grill over medium flame, turning occasionally until thoroughly cooked. This may take 30 minutes. Remove from grill and cool for handling. Strip off the skin and chop eggplant finely. Add all the seasonings. Chill thoroughly and serve on toast.

## The smoker system:

**Figure 18-1 36"/48" GRILL SMOKER SYSTEM:**

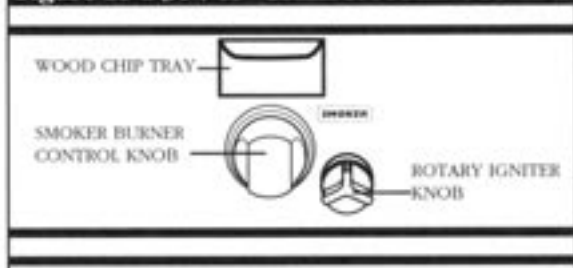

**Figure 18-2 27" GRILL SMOKER SYSTEM:**

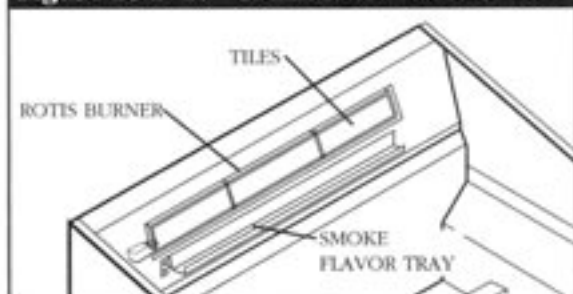

### 36" / 48" GRILL MODELS ONLY:

The smoker system on each Professional Grill consists of a stainless steel slide out tray which is positioned above a 5,000 BTU burner. The burner is controlled by a precision brass valve which is capable of being turned down to very low heat levels. The system may be used alone for low temperature roasting and smoking or in conjunction with any combination of other burners.

When using the smoker system in conjunction with the optional infrared rotisserie burner you'll find it helpful to use the low setting of the smoker burner to minimize the heat rising up to the rotis basting pan. Staggering the meat away from the smoker burner also helps.

### 27" GRILL MODELS ONLY:

#### The smoke flavor tray:

Located directly beneath the rotis burner is a stainless steel tray which is designed to hold wood chips or herbs for adding a smoke flavor to foods.

## Wood chips:

**To minimize burn potential do not remove the smoker tray when hot.**

### ALL GRILL MODELS:

There are many wood chips available for purchase and selection is based on personal taste. The most common wood chips used are mesquite or hickory. Mesquite has a sweeter taste and is commonly used with poultry and seafood. Hickory is best suited for red meats. Use of oak, cherry, maple, aspen or apple is also common while aromatic herbs like sage, bay leaves, thyme or basil may also be used.

Always soak the chips in water prior to putting them into the tray. To start you may want to use the "HI" position to start the chips smoking, then reduce the heat to a lower level to prevent them from drying out and flaming. If the wood chips do flame up add a small amount of water to extinguish the flame. This should be done carefully through the top in the grill area, or by pulling the tray out slightly. Use caution when adding water to a hot tray to avoid steam burns, and never completely remove a hot tray.

The tray may also be filled with water to produce steam. Whether smoking or steaming the lid should remain closed as much as possible to maximize the effect.

During extended roasting periods it is normal to add fresh wood chips to the tray several times.

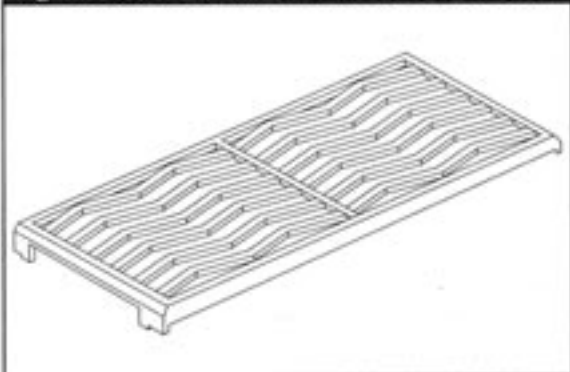
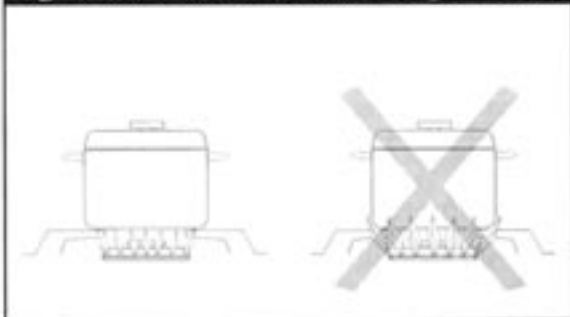
**Power burners:***(36" / 48" BQRS Models Only)***Figure 19-1 Power Burner Porcelain Grate****Figure 19-2 Power Burner Proper Flame****36" / 48" BQRS MODELS ONLY:**

Your Professional Grill is equipped with the same heavy cast iron burners which we use on our line of quality restaurant ranges. Each is rated at 15,000 BTU and has a rotary spark igniter for efficient lighting. The burner grates (see Fig. 19-1) are porcelain enamel over cast iron for durability.

To cover the power burners when not in use, each grill comes with a stainless steel cover which doubles as a work surface. When using the grill burners with the work surface in place, be careful as heat can conduct from the grill section and cause the work surface to heat up. **NEVER** attempt to light the power burners with the work surface in place.

**FLAME HEIGHT:**

The correct height of the flame depends on the size and material of the utensil being used, the food being cooked and how much liquid is in the utensil. Here are some basic rules for selecting the flame height.

- The flame should never extend beyond the bottom of the pan. (see Fig. 19-2)
- Utensils which conduct heat slowly (such as glass-ceramic) should be used with a low or medium flame unless you are cooking with a large amount of liquid.

## The rotis system:

*BQRS and BQARS Series only*

**Figure 20-1 36"/48" Grill Rotisserie System:**



**Figure 20-2 27" Grill Rotisserie System:**



The rotisserie motor must be electrically grounded in accordance with local codes or, in the absence of local codes, with the National Electrical Code, ANSI/NFPA 70-1990.

**Keep the rotis motor electric cord away from the heated surfaces of the grill. When not in use remove and store the motor in a dry location.**

### **WARNING: Electrical Grounding Instructions**

This appliance (rotisserie motor) is equipped with a three-prong (grounding) plug for your protection against shock hazard and should be plugged directly into a properly grounded three-prong receptacle. Do not cut or remove the grounding prong from this plug.

The Professional Grill rotis system is designed to cook items from the back using infrared heat. The location of the burner allows the placement of the rotis basting pan (included) beneath the food to collect juices and drippings for basting and gravy. To flavor the contents of the basting pan, you can add herbs, onion, garlic, or spices. Hams are especially good with the addition of pineapple slices and brown sugar to the basting pan.

The rotisserie burner is an infrared type which provides intense searing radiant heat. Preferred by professional chefs over other methods, this intense heat is magnificent for searing in the natural juices and nutrients found in quality cuts of meat.

Once lit, the rotis burner will reach cooking temperatures in about 1 minute. The orange/red glow will even out in about 5 minutes.

The rotis motor is equipped with metal gears and is capable of turning up to a 25 lb. cut of meat or poultry. On the **27" Grills**, (see Fig. 20-2) the motor is mounted to a metal channel which attaches to the left side of the grill and gets tightened into place with a thumb screw. Ensure that the motor is straight prior to tightening the thumb screw. The rotis motor on the **36" / 48" Grills** is secured down to a cast rotis block with the black screw-down knob. The rotis block is in turn bolted to the right side panel. (see Fig. 20-1)

On 36" and 48" Grills, the skewer for the rotis is assembled into the motor assembly by placing the pointed end into the motor, and resting the threaded end on the support at the left side of the grill (*right side on 27" Grills*). With the skewer pushed as far as possible into the motor, the grooved skewer bushing should rest on the left side bracket. The removable black handle should only be in place when handling the skewer. Except on BQAR and 27" units, remove the handle when cooking to allow the lid to close and avoid melting the handle with heat from the power burners. (see Figs. 20-1, 20-2)

To load the skewer begin with the handle in place, and slide one of the meat holders (prongs facing away from the handle) onto the skewer. Push the skewer through the center of the food, then slide the second meat holder (prongs toward the food) onto the skewer. Center the product to be cooked on the skewer then push the meat holders firmly together. (Some models have grooves on the skewer to indicate the burner position. Use them to position the meat holders.) Tighten the wing nuts with pliers. It may also be necessary to wrap the food with butchers string (never use nylon or plastic string) to secure any loose portions. Once the food is secure insert the skewer into the motor. If needed, remove the grill racks. Place the basting pan beneath the food. It is normal for the skewer to flex when larger cuts of meat are being cooked.





**Before lighting:**

**⚠ WAIT 5 MINUTES BEFORE RELIGHTING A HOT GRILL.**

Keep a spray bottle of soapy water near the gas supply valve and check the connections for gas leaks before each use.

**⚠ WARNING: IMPORTANT! Before lighting . . .**

Inspect the gas supply piping or hose prior to turning the gas "on". If there is evidence of cuts, wear, or abrasion, it must be replaced prior to use. Any replacement pressure regulators or hose assembly must be the type specified by the manufacturer. Do not use the Professional Grill if the odor of gas is present. For LP use the pressure regulator and hose assembly supplied with the unit must be used.

If the unit is L.P., connect the regulator to the tank and leak check the hose and regulator connections with a soap and water solution before operating the Professional Grill.

Turn all knobs to "off" then turn on the gas supply. If L.P., is there gas in the tank?

Always keep your face and body as far away from the grill as possible when lighting.

**To light grill burners:**

Do not attempt to "Lite" the grill if the odor of gas is present. Call for service.

Open the lid, push and turn the control knob to the "lite" position and immediately turn the rotary igniter knob of the spark igniter next to the burner knob. You'll hear a snapping sound. At the same time a spark will be provided at the grill burner. It may be necessary to turn the rotary igniter knob several times until the burner is lit. If the burner does not light in 4 seconds, turn knobs to "off" and wait 5 minutes before trying again for any accumulated gas to dissipate. If the burner will not light after several attempts then the burner can be match lit. Remove the grill rack over the burner(s) you wish to light. If you've just attempted to light the burner with the igniter, allow 5 minutes for any accumulated gas to dissipate. Keep your face as far away from the grill as possible and pass a lit, long stem match through the lava radiant and position it near the burner ports. Make sure that the match is adjacent to the burner ports. Push and turn the control knob which is centered on the burner where the lit match is located, to "lite". If the burner does not light in 4 seconds turn the knob off, wait 5 minutes and try again. If the burner will not light after several attempts see Section 14: Troubleshooting.

**To light power burners:**

(48/36BQR, BQRS Models Only)

Figure 23-1 Power Burners:

**Power Burners - 48/36 BQR, BQRS Models Only:**

First remove the burner cover or any cooking utensils from the burner grate. **CAUTION: The burner cover may be hot if the grill burners are in operation.** Push and turn the control knob to the "lite" position and immediately turn the rotary igniter knob between the "Rear" and "Front" knobs until the burner is lit or 4 seconds pass. If the burner doesn't ignite wait 5 minutes for any accumulated gas to dissipate then try again. If the burner will not light after several attempts, wait 5 minutes and then the burner can be match lit by holding a lit match next to the burner ports and turning the correct valve to "Lite".

## To light the smoker burner:

48/36BQ(A)(R)(S) Models only

Figure 26-1 36"/48" Pull-out Smoker Tray:



Figure 26-2 27" Smoke Flavor Tray:



Open the lid and remove the smoker tray. Locate the burner visually by looking through the cut-out in the valve panel. Push and turn the control knob to the "Lite" position and immediately turn the smoker rotary igniter knob (which is to the immediate right of the smoker knob) until the burner is lit or 4 seconds pass. If the burner doesn't ignite wait 5 minutes for any accumulated gas to dissipate then try again. If the burner will not light after several attempts, wait 5 minutes then match light using a long stemmed match or lighter through the cut-out in the valve panel. Once lit, fill the smoker tray and replace.

\*NOTE: Because of the location of the Smoke Flavor Tray on the 27" BQR Model, the rotis burner acts as the burner for the Smoke Flavor Tray. (see figure 26-2)

## To light the rotis burner:

All BQR Series Only

**Wait 5 minutes  
before relighting  
a hot rotis burner.**

The location of the rotis burner makes it more susceptible to strong wind conditions, more so than the protected grill burners. For this reason you should avoid utilizing it during windy conditions. As an added precaution we've equipped the burner with an automatic safety valve which will not allow gas to flow to the rotis burner unless the following conditions are present with the knob on:

1. The safety valve button is pressed, or
2. The safety probe is sufficiently heated to open the valve.

Figure 26-3 Rotisserie control, igniter, safety:



### TO LIGHT:

Open the lid. Push and turn the control knob to the "Lite" position. Press the safety valve button, hold in, and begin turning the rotary igniter button located next to the rotis knob. It may be necessary to turn the igniter knob several times until the burner lights. You'll hear a snapping sound. At the same time, a spark will be provided at the safety probe. Hold the safety valve button in for about 5 seconds or until the burner remains lit. This is the only burner on the professional grill with a safety valve. Once lit, turn control knob to desired setting. If the burner does not light within 4 seconds, release the safety valve button and turn the control knob to "off".

If the igniter does not function, the burner can be lit by holding a lit match to the burner (with the control knob at "Lite" and the safety valve button pressed).

**Cleaning the grill:****GRILL RACK:**

The easiest way to clean the grill is immediately after cooking is completed and after turning off the flame. Wear a barbecue mitt to protect your hand from the heat and steam. Dip a brass bristle barbecue brush in tap water and scrub the hot grill. Dip the brush frequently in the bowl of water. Steam, created as water contacts the hot grill, assists the cleaning process by softening any food particles. The food particles will fall onto the hot lava rocks and burn or fall into the drip tray. If the grill is allowed to cool before cleaning, cleaning will be more difficult.

**DRIP TRAYS:**

The full width drip trays will collect grease from the grill section and boilovers and spills from the power burners. Allow the pan and its contents to cool before attempting to clean. Clean grease from the pan often to avoid the possibility of a grease fire.

**LAVA ROCK:**

It is not necessary to remove the lava rock for cleaning. They burn themselves clean during the next cooking operation. Periodically the rocks need to be turned over for a thorough cleaning. How often you use the grill and the amount and type of food cooked will determine when it is necessary to clean the lava rock. If grease can be seen on the top of the rocks or if you get a lot of flare-up during cooking, the rocks need to be turned over and heated on "high" for 30 minutes; longer for heavy soil.

**BURNER GRATES:**

The top burner grates are porcelain enamel over cast iron for durability. To avoid burns do not clean a hot grate. They may be wiped while in place with hot, soapy water, rinsed and wiped dry. Never immerse a hot grate in water.

Due to rapid temperature changes the porcelain may pop off the edges of the grates. Do not be concerned as the base metal, cast iron, soon darkens to blend with the porcelain enamel. Use care when wiping areas where the enamel has popped off. The edges may be sharp.

If cleaning necessitates grate removal, care should be taken in lifting them. They are very heavy. Be sure to place them on a protected surface.

**STAINLESS STEEL:**

The Professional Grill is made from non-rusting and non-magnetic stainless steel. After initial usage, areas of the grill may discolor from the intense heat given off by the burners, this is normal.

There are many different stainless steel cleaners available. Always use the mildest cleaning procedure first, scrubbing in the direction of the grain. To touch up noticeable scratches in the stainless steel, sand very lightly with dry 100 grit emery paper in the direction of the grain. Specks of grease can gather on the surfaces of the stainless steel and bake on to the surface and give the appearance of rust. For removal use an abrasive pad (Scotch Brite is good) in conjunction with a stainless steel cleaner. Always rub in the direction of the grain. Never scrub the stainless steel with steel wool. Steel particles left on the stainless steel will soon rust and give the appearance that the parts are rusting.

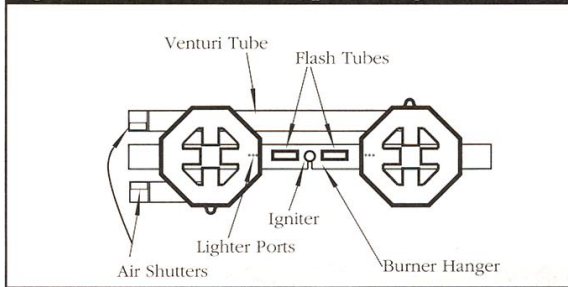
**Figure 26-1 Power Burner (top view w/grate removed)****GRILL AND POWER BURNERS:**

The grill and power burners (*BQRS Models Only*) are cast iron coated with porcelain enamel. Occasionally it will be necessary to remove surface rust to ensure proper performance. Frequency of cleaning will depend on the climate & location, and how often you use the grill. The walls of the burners are thick so they can withstand many years of use.

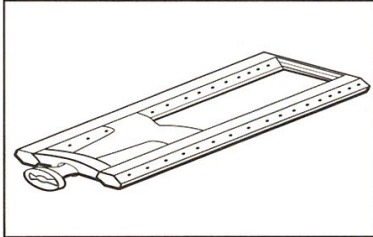
**Figure 26-2 Grill Burner****BEFORE REMOVING:**

Ensure the gas supply is off and the knobs are in the "off" position. Make sure the grill is cool.

**GRILL BURNER:**

Remove the grill racks, then lift out the lava rock support; complete with the lava rocks still in the support. Grasp the burner, pull it up and slightly to the rear of the unit so the burner head comes off the brass orifice at the front, angle the burner sideways, and remove.

**POWER BURNER (Standard on 36/48 BQRS Models Only):**

Remove the top grate. Lift out aeration pan from around burners. Lift and remove the front and rear power burners. (*see Fig. 26-1*)

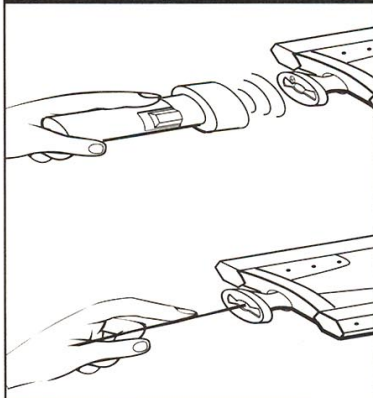
**Figure 26-3 Inspect Grill Burner****BURNER CLEANING:**

Clean the exterior of the burner with a wire brush. Clear any clogged ports with a straightened paperclip. Never use a wooden toothpick as it may break off and clog the port. Shake out any debris through the air shutter.

Use a flashlight as shown in Figure 26-3 to inspect the burner inlet to ensure it is not blocked. If obstructions can be seen, use a metal wire coathanger that has been straightened out.

**Note:** To ensure warranty coverage and proper performance of the grill and power burners, DCS recommends monthly inspection and cleaning of the grill and power burners and orifice as described herein.

**Be sure burner ports are clear and free from debris.**

**ORIFICE CLEANING:**

With the burner removed, remove the orifice (see Part List Item #27 p.30 & 32 for location of orifice) and shine a flashlight through the opening to ensure there is no blockage. Use a needle to clear any debris. Be extremely careful not to enlarge the hole or break off the needle.

**SMOKER BURNER:**

The smoker burner can be removed and cleaned by unplugging the igniter wire and lifting out the burner. Cleaning is similar to the grill burner.

**TO REASSEMBLE THE BURNERS:**

Replace the burner by sliding the air shutter over the brass orifice, centering it in the hole.

**\* IT IS EXTREMELY IMPORTANT TO CENTER THE BURNER ON THE ORIFICE PROPERLY.**

Be careful not to upset the air shutters' original position (unless readjusting). Lower the rear of the burner into the cutouts on the support channel at the rear of the burner box. Make sure it is level and does not rock.

Replace the lava radiant so that the slots in the corners of the radiant align with the projections on the top of the burner. Make sure that it sits level and does not rock.

Light all of the burners and check for proper flame characteristics. If adjustments are necessary, refer to Section Six. If the grill or smoker burner was repainted, operate the section on "HI" for at least 1/2 hour or until any odor of burning paint has gone. Do this prior to cooking on the grill.

**REPLACING A ROTARY  
IGNITER**

**BEFORE REPLACING  
AN IGNITER, PERFORM  
THIS SIMPLE TEST. . .**

Remove the drip tray. From underneath the valve panel, look upwards and locate the end of the igniter wire, where it is connected. Disconnect the wire and place the

metal blade of a screwdriver about 1/8" from the terminal of the rotary igniter. Turn the igniter knob. If the igniter is good, a spark will jump across to the screwdriver. If no spark, replace the igniter.

If there is a spark, examine the wire of the electrode for cracks and cuts. Also examine the electrode for grease and debris or see if the electrode tip is bent. Is the tip sparking to the top of the electrode bracket?

The rotary igniter may be replaced from the front by removing the drip pan and reaching behind the valve panel to unplug the igniter wire. Remove the igniter knob and the two mounting screws. Reverse procedures to replace. If removing the valve panel is necessary begin by removing all the knobs, then remove the (4) corner screws of the valve panel.

**! SPIDER AND INSECT  
WARNING!!!**

Spiders and insects can nest in the burners of this or any other grill, and cause the gas to flow from the front of the burner. This is a very dangerous condition which can cause a fire to occur behind the valve panel, thereby damaging the grill and making it unsafe to operate.

**WHEN TO LOOK FOR  
SPIDERS**

You should inspect the burners at least once a year or immediately if any of the following conditions occur:

1. The smell of gas in conjunction with the burner flames appearing yellow.
2. The Professional Grill does not reach temperature.
3. The Professional Grill heats unevenly.
4. The burners make popping noises.

**BEFORE CALLING FOR  
SERVICE**

If the Professional Grill does not function properly, use the following checklist before contacting your dealer for service. You may save the cost of a service call.

<b>PROBLEM</b>	<b>WHAT TO DO</b>
<b>Grill won't light when the rotary igniter is turned.</b>	<p>Remove the grill rack and the lava radiant, watch the igniter tip. You should see a spark jump from the tip of the igniter when the knob is turned.</p> <p>If there is no spark when the rotary igniter knob is turned,</p> <p>Check the gas supply to the unit and purge the line of any air.</p> <p>Attempt to match light the burner.</p> <p>Check to see that other burners on the unit operate.</p> <p>Clean igniter tip of any debris.</p>
<b>Burner flame is yellow or orange, in conjunction with the odor of gas.</b>	<p>Check the burner inlet for obstructions. See Section 11.</p> <p>Check the air shutter for proper adjustment. See Section 6.</p> <p>Grill may be in a dusty area. Move to less dusty area if possible.</p>
<b>Low heat with knob in "HI" position.</b>	<p>If only one of the burners appears low, clean the orifice and burner, clearing ports of any obstructions.</p> <p>Check that air shutter is properly adjusted, (not too far open or closed) see pg. 9</p> <p>Check for proper gas supply and pressure. (see pg 4-5, gas requirements.</p> <p>Pre-heat grill for a full 15 minutes.</p> <p>If using L.P. gas, check for empty tank.</p> <p>Check for spark at thermocouple. If no spark exists when rotary igniter turned, attempt to match light burner.</p>
<b>Optional rotis won't light.</b>	<p>If there a spark at the thermocouple? Can you match light the burner?</p>
<b>Optional rotis lights, but will not hold flame once button is released.</b>	<p>Continue holding safety valve button in depressed position until burner remains lit when released.</p>

**Figure 30-1 36" / 48" Grill Parts:**

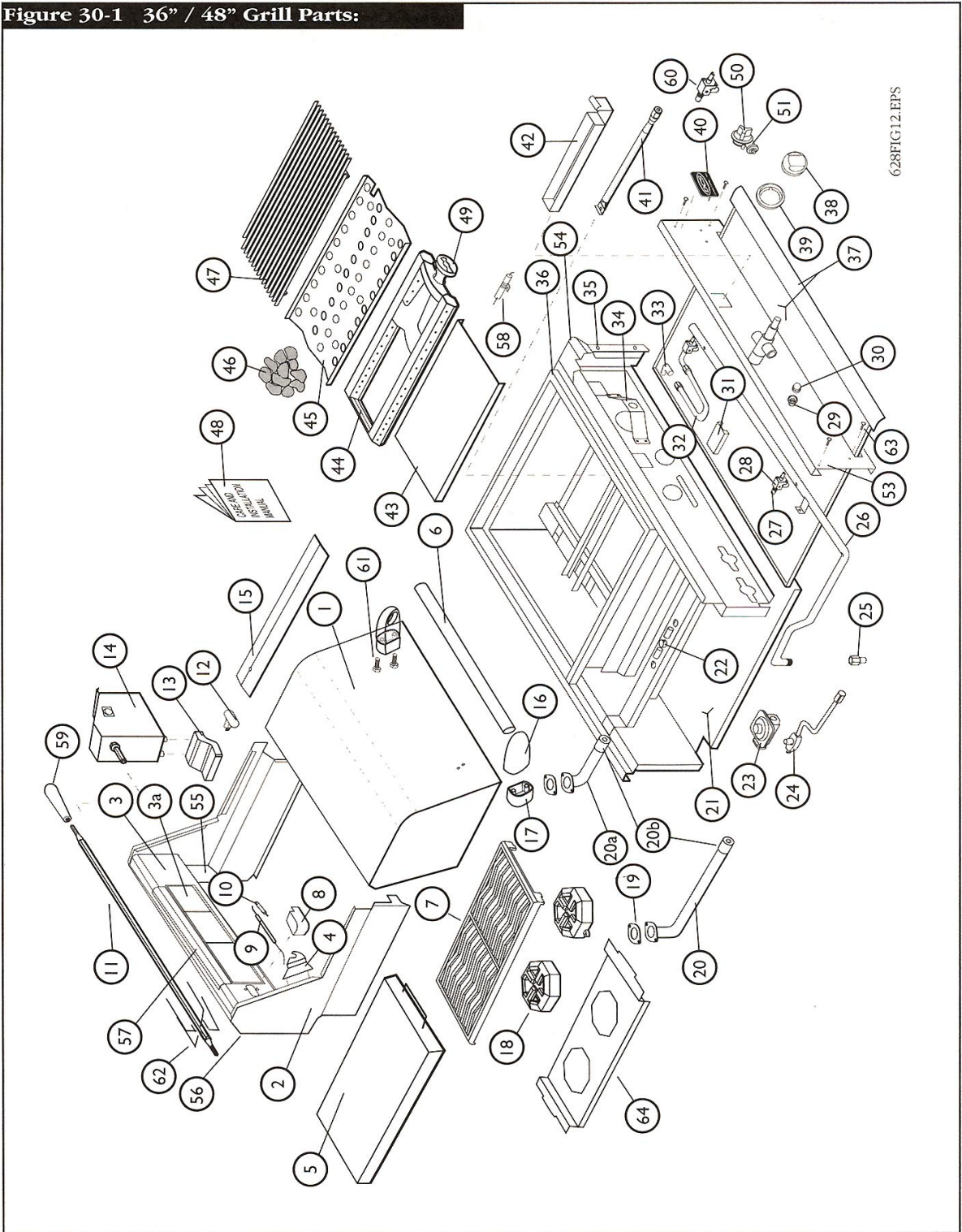

628FIG12.EPS

ITEM NO.	DESCRIPTION	PART NO.	ITEM NO.	DESCRIPTION	PART NO.
1.	Roll-top lid assembly	32066-XX	36.	Side body panel	30644-XX
2.	Firebox weld assembly	32068-XX	37.	Drip pan/handle	32067-XX
3.	*Rotis. burner housing	32008-XX	38.	Grill burner control knob	14154
3.	Housing (non-rotis models)	32092-XX	39.	Knob bezel	14006-PL
3a.	*Rotisserie burner	12021-XX	40.	DCS Logo	17103-01
4.	*Rotis rod bracket	32077	41.	Smoker burner assembly	30639
5.	Side burner cover	32060-XX	42.	Smoker burner tray	32038
6.	Handle Tube	32048-XX	43.	Heat shield	30538
7.	O/T burner Top Grate	12006-01	44.	"H" burner	12012-02
8.	*Electrode cover	32047-XX	45.	Lava rock support	30522
9.	*Electrode-Rotis.	13055-05	46.	Lava rock- 4 lb. bag	10312
10.	*Thermocouple	13007-02	47.	Grill rack	19006
11.	*Rotisserie rod	19054-XX	48.	Care & Installation manual	10628
12.	*Rotis. mount knob	14161	49.	Air shutter	12003-02
13.	*Rotis. mount base	14155	50.	Rotary igniter knob	14159
14.	*Rotisserie motor assy.	32069	51.	Rotary igniter	16190
15.	Top heat shield	30539	52.	*Safety valve	18110
16.	Handle endcap	18164-PL	53.	Valve panel	32000-XX
17.	Handle endcap spacer	18174	54.	Landing ledge assy.	32053-XX
18.	Hex burner	12000-02-PC	55.	Corner tubing cover(48" models)	32051-XX
19.	Gasket	14000		(36" models)	32052-XX
20.	Venturi - Long	12007-02	56.	Service panel	32007-XX
20a.	Venturi - Short	12007-01	57.	*Protection plate	32070-XX
20b.	Air shutter	12003-02	58.	Grill Electrode	13012-6
21.	Burner box bottom/back	30642-XX	59.	Rotisserie Handle	18040
22.	O/T Electrode assembly	16002-03	60.	Smoker Valve	13017-01
23.	Regulator- Natural gas	13035	61.	Shoulder Bolt (4)	15089-3
24.	Regulator/Hose Asmbly-L.P.	13077	62.	Four Prong Meat Holder	19010
25.	1/2 x 3/8 Flared adapter	18053	63.	Valve Panel Screws (4)	15002-31
26.	Manifold	18031-XX	64.	Aeration Pan	32034
27.	Orifice-O/T burner Nat. gas	13005-XX	Items not pictured		
27.	Orifice-O/T burner L.P. gas	13005-XX	<b>Roll Top Lid Hinge Parts:</b>		
28.	Control valve	13017	Shoulder Bolt (2)	15089-3	
29.	*Safety valve bezel	14160	Acorn Nut (2)	150904	
30.	*Safety valve knob	14108	Keps Nut (6)	15021-04	
31.	Valve shield	30630	Quick Disconnect	18178-5LPA	
32.	Stainless steel tubing	11002	Plug adapter	18177	
33.	Orifice elbow	18020-02	* BQR Series only		
34.	Orifice elbow bracket	30616-01	XX= Specify model number of grill and (left) or (right)		
35.	Tinnerman clip	15023-02	(if applicable)		

# PROFESSIONAL 27" GRILL PARTS

Figure 32-1 27" Grill Parts:

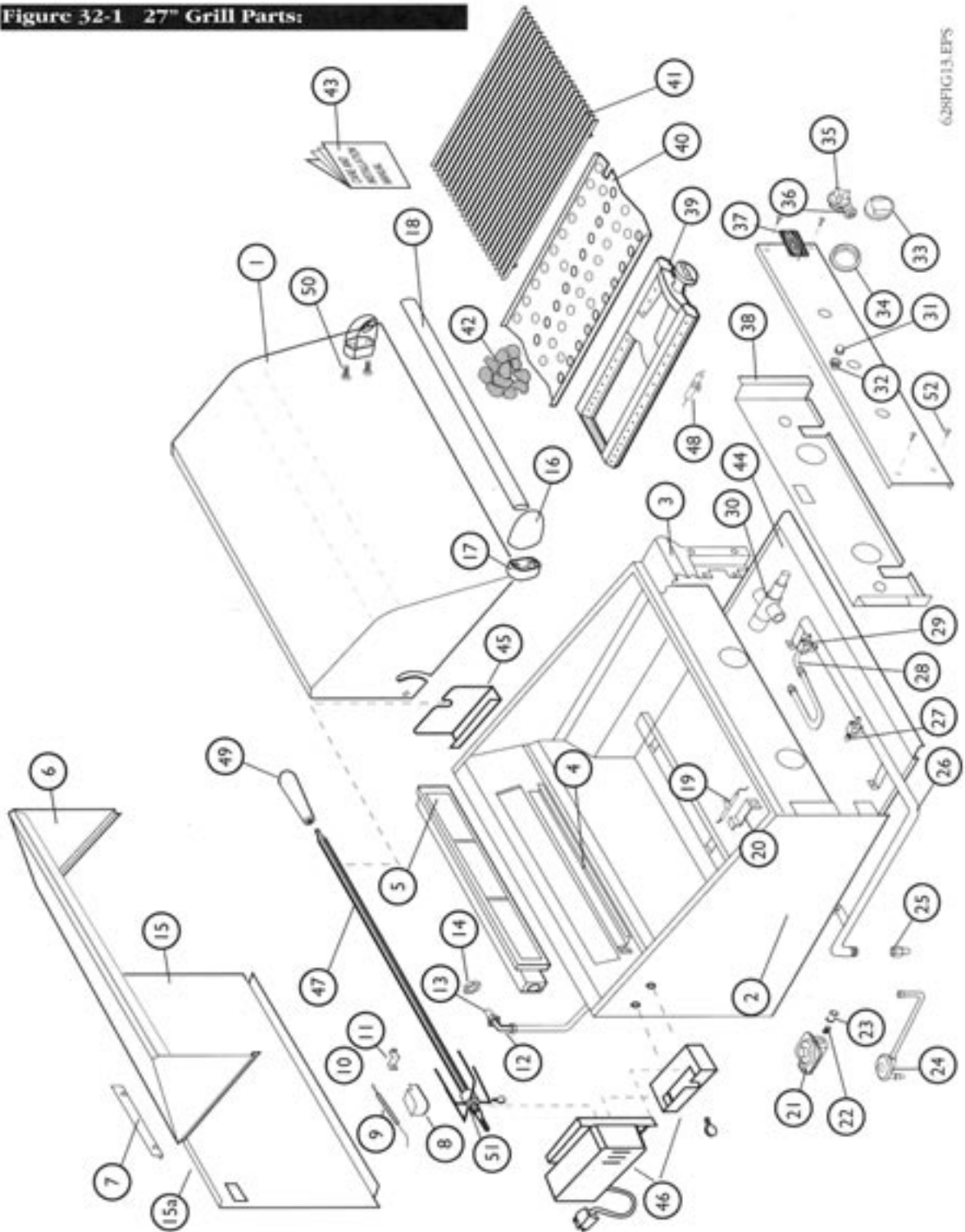

628FIG13.EPS

**PROFESSIONAL 27" GRILL PART LIST**

ITEM NO.	DESCRIPTION	PART NO.	ITEM NO.	DESCRIPTION	PART NO.
1.	Roll-top lid assembly	32030-02	36.	Rotary igniter	16190
2.	Body Assembly	30735-XX	37.	DCS Logo	17103-01
3.	Landing ledge assembly	32043	38.	Heat shield	30724
4.	Smoke flavor tray	30729	39.	"H" burner	12022
5.	Rotisserie burner	12021-02	40.	Lava rock support	30709-020
6.	Base folding lid	32031	41.	Grill rack	19014-PC
7.	Lid stop #7	30138	42.	Lava rock- 4 lb. bag	10312
8.	Electrode cover	30741	43.	Care & Installation manual	10628
9.	Thermocouple	13007-02	44.	Drip pan assembly	32042
10.	Electrode-Rotis.	13055-06	45.	Rotis motor bracket	30757
11.	Thermocouple bracket	30682	46.	Rotis motor assembly (includes motor bracket)	30860-01
12.	Rotisserie fitting	18020-01	47.	Rotisserie Rod	19054-03
13.	Orifice-Rotis burner L.P.gas	13005-57	48.	Grill Electrode	13012-6
13.	Orifice-Rotis burner Nat.gas	13005-50	49.	Rotissere Handle	18040
14.	Pal nut	15071	50.	Shoulder Bolt (4)	15089-3
15.	Back panel	32023-XX	51.	Four Prong Meat Holder	19010
15a.	Service panel	32027	52.	Valve Panel Screws (4)	15002-31
16.	Handle endcap	18164-PL			
17.	Handle endcap spacer	18174			
18.	Handle Tube	32048-05			
19.	Electrode	13012-06			
20.	Electrode bracket	30711-020			
21.	Regulator- Natural gas	13035			
22.	1/2 NPT Close nipple	18018-01			
23.	1/2 Coupling	18019			
24.	Regulator/Hose Asmbly-L.P.	13077			
25.	1/2 x 3/8 Flared adapter	18033			
26.	Manifold	18034			
27.	Orifice-Grill burner Nat. gas	13005-44			
27.	Orifice-Grill burner L.P. gas	13005-55			
28.	90° Elbow	18030			
29.	Manual valve	13017			
30.	Safety valve	18110			
31.	Safety valve button	14108			
32.	Safety valve bezel	14160			
33.	Control knob	14154			
34.	Control knob bezel	14006-PL			
35.	Rotary igniter knob	14159			

Items not pictured

Roll Top Lid Hinge Parts:

Truss Screw (2)	15002-26
Keps Nut (2)	15021-04
Nut (2)	15004-04

XX = Specify Model # of grill

**SERVICE AND LIMITED WARRANTY**

If the Professional Grill does not operate properly, first thoroughly carry out the instructions provided in Section 14, Troubleshooting, and ensure that the appliance is installed as outlined in Sections Two through Seven. If the problem persists and you feel you require service, contact your dealer or the nearest authorized agency to perform service. Only authorized agencies can perform warranty service. Dynamic Cooking Systems will not pay for service calls to:

- A. Correct the installation.
- B. Instruct you how to use the equipment.
- C. Repairs when the appliance is used on other than normal home use.
- D. Damage resulting from accident, alteration, misuse, abuse, hostile environments, improper installation or installation not in accordance with local codes.

***\*Lifetime Warranty on all Stainless Steel components*****LIMITED WARRANTY*****Five Year Warranty***

This warranty covers the cast iron burners, the structural integrity of the exterior and interior body parts, stainless steel lava radiant, upper and lower heat shields, grill racks, and drip pans. Should structural deterioration occur to the degree of non-performance, a replacement will be furnished.

***One Year Warranty***

Dynamic Cooking Systems warrants all other grill components to the original purchaser to be free of factory defects in material and workmanship for a period of one year from the original date of purchase. This does not apply if the unit was subjected to other than normal household use.

No charges will be made for repair or replacement at the location of initial installation or factory for parts returned pre-paid, through the dealer and claimed within the warranty period, and found by Dynamic Cooking Systems Inc. to be defective.

Replacement will be F.O.B. Dynamic Cooking Systems, and Dynamic Cooking Systems will not be liable for any transportation costs, labor costs, or export duties.

This warranty shall not apply, nor can we assume responsibility for

damage that might result from failure to follow manufacturers instructions or local codes, where the appliance has been tampered with or altered in any way or which, in our judgement, has been subjected to misuse, negligence, or accident. Implied warranty shall not extend beyond the duration of this written warranty.

This warranty is in lieu of all other warranties expressed or implied and all other obligations or liability in connection with the sale of this appliance.

Replacement parts can be obtained from:

Dynamic Cooking Systems, Inc.  
5800 Skylab Road  
Huntington Beach, CA 92647

Date Warranty Card was mailed:

---

---

As product improvement is an ongoing process at DCS, we reserve the right to change specifications or design without notice.

---

Litho in USA 11-96  
Part No. 10628 Rev. 3

5800 Skylab Road Huntington Beach, CA 92647  
(714) 372-7000 Fax (714) 372-7001  
Direct Parts/Customer Service (888) 281-5698



Dynamic Cooking Systems Inc.