

This Owner's Manual is provided and hosted by [Appliance Factory Parts](#).



# Kenmore 58829 Owner's Manual

[Shop genuine replacement parts for Kenmore 58829](#)



[Find Your Kenmore Refrigerator Parts - Select From 665 Models](#)

----- Manual continues below -----



# SIDE-BY-SIDE REFRIGERATOR

Use & Care Guide

# REFRIGERADOR DE DOS PUERTAS

Manual de Uso y Cuidado

# RÉFRIGÉRATEUR CÔTE À CÔTE

Guide d'Utilisation et d'Entretien

Models / Modelos / Modèles 795.5882\*

\*=color number, número de color, numéro de couleur

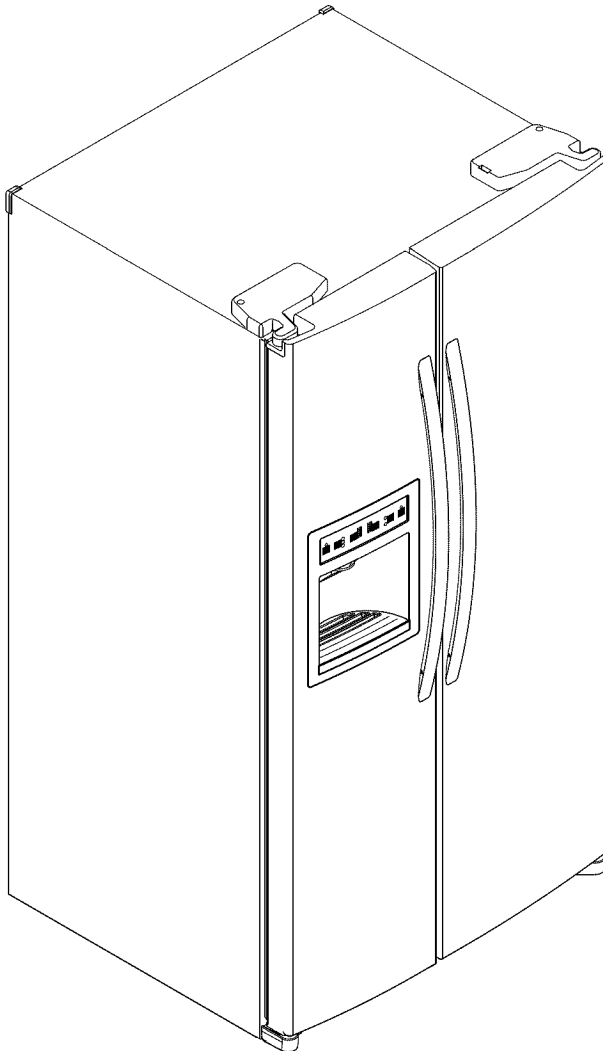

ENGLISH ESPAÑOL FRANÇAIS

# TABLE OF CONTENTS

<b>Warranty</b>	<b>3</b>	Crisper and Crisper Cover	17
<b>Protection Agreements</b>	<b>4</b>	Freezer Compartment Shelf	17
<b>Product Record</b>	<b>4</b>	Ice Storage Bin	17
<b>Important Safety Instructions</b>	<b>5-6</b>	Door Rack and Support	17
<b>Refrigerator Features</b>	<b>7</b>	Water Filter	18-19
<b>Refrigerator Installation</b>	<b>8-12</b>	<b>Care and Cleaning</b>	<b>20-21</b>
Unpacking your refrigerator	8	General Cleaning Tips	20
Installation	8	Outside	20
Base Grille Installation	8	Inside Walls	20
Leveling the Refrigerator	9	Door Liners and Gaskets	20
Handle Removal	9	Plastic Parts	20
Removing and Replacing Refrigerator Doors	10-11	Back Cover	20
Door Alignment	12	Power Interruptions	21
After Leveling the Door Height	12	When you go on vacation	21
<b>Using Your Refrigerator</b>	<b>13-19</b>	When you move	21
Ensuring Proper Air Circulation	13	<b>Icemaker Operation</b>	<b>22</b>
Next	13	When you should set the icemaker power switch to off	22
Setting the Control	13	Normal sounds you may hear	22
Refrigerator and Freezer Controls	13	<b>Connecting the Water Line</b>	<b>23-25</b>
Adjusting Control Settings	15	Before you begin	23
Food Storage Guide	15	What you will need	23
Storing Frozen Food	16	Installation Instructions	23-25
Water Dispenser	16	<b>Troubleshooting Guide</b>	<b>26-30</b>
Refrigerator Shelves	17		



## SIDE-BY-SIDE REFRIGERATOR

### Kenmore Elite Refrigerator Warranty

#### One Year Limited Warranty

When installed, operated and maintained according to all instructions supplied with the product, if any non-consumable part of this appliance other than the sealed refrigerant system fails due to a defect in material and workmanship within one year from the date of purchase, call 1-800-4-MY-HOME® to arrange for free repair. This coverage applies for only 90 days from the date of purchase if this appliance is ever used for other than private family purposes.

If the sealed refrigerant system is defective within five years from the purchase date, call 1-800-4-MY-HOME® to arrange for free repair. This coverage applies for only one year from the date of purchase if this appliance is ever used for other than private family purposes.

#### **This Warranty covers only defects in material and workmanship. Sears will NOT pay for:**

1. Expendable items that can wear out from normal use, including but not limited to filters, belts, light bulbs, and bags.
2. A service technician to instruct the user in correct product installation, operation or maintenance.
3. A service technician to clean or maintain this product.
4. Damage to or failure of this product if it is not installed, operated or maintained according to the all instructions supplied with the product.
5. Damage to or failure of this product resulting from accident, abuse, misuse or use for other than its intended purpose.
6. Damage to or failure of this product caused by the use of detergents, cleaners, chemicals or utensils other than those recommended in all instructions supplied with the product.
7. Damage to or failure of parts or systems resulting from unauthorized modifications made to this product.

#### **Disclaimer of implied warranties; limitation of remedies**

Customer's sole and exclusive remedy under this limited warranty shall be product repair as provided herein. Implied warranties, including warranties of merchantability or fitness for a particular purpose, are limited to one year or the shortest period allowed by law. Sears shall not be liable for incidental or consequential damages. Some states and provinces do not allow the exclusion or limitation of incidental or consequential damages, or limitation on the duration of implied warranties of merchantability or fitness, so these exclusions or limitations may not apply to you.

This warranty applies only while this appliance is used in the United States or Canada.

This warranty gives you specific legal rights, and you may also have other rights which vary from state to state.

**Sears, Roebuck and Co., Hoffman Estates, IL 60179  
Sears Canada, Inc., Toronto, Ontario, Canada M5B 2B8**

# PROTECTION AGREEMENTS

## Master Protection Agreements

*Congratulations on making a smart purchase.* Your new Kenmore® product is designed and manufactured for years of dependable operation. But like all products, it may require preventive maintenance or repair from time to time. That's when having a Master Protection Agreement can save you money and aggravation.

The Master Protection Agreement also helps extend the life of your new product. Here's what the Agreement\* includes:

- Parts and labor** needed to help keep products operating properly **under normal use**, not just defects. Our coverage goes **well beyond the product warranty**. No deductibles, no functional failure excluded from coverage - **real protection**.
- Expert service** by a force of more than 10,000 authorized **Sears service technicians**, which means someone you can trust will be working on your product.
- Unlimited service calls and nationwide service**, as often as you want us, whenever you want us.
- "No-lemon" guarantee**- replacement of your covered product if four or more product failures occur within twelve months.
- Product replacement** if your covered product can't be fixed.
- Annual Preventive Maintenance Check** at your request - no extra charge.
- Fast help by phone** - we call it **Rapid Resolution** - phone support from a Sears representative on all products. Think of us as a "talking owner's manual."
- Power surge protection** against electrical damage due to power fluctuations.
- \$250 Food Loss Protection** annually for any food spoilage that is the result of mechanical failure of any covered refrigerator or freezer.
- Rental reimbursement** if repair of your covered product takes longer than promised.
- 10% discount** off the regular price of any non-covered repair service and related installed parts.

Once you purchase the Agreement, a simple phone call is all that it takes for you to schedule service. You can call anytime day or night, or schedule a service appointment online.

The Master Protection Agreement is a risk free purchase. If you cancel for any reason during the product warranty period, we will provide a full refund. Or, a prorated refund anytime after the product warranty period expires. Purchase your Master Protection Agreement today!

**Some limitations and exclusions apply. For prices and additional information in the U.S.A. call 1-800-827-6655.**

**\*Coverage in Canada varies on some items. For full details call Sears Canada at 1-800-361-6655.**

### Sears Installation Service

*For Sears professional installation* of home appliances, garage door openers, water heaters, and other major home items, in the U.S.A. or Canada call **1-800-4-MY-HOME®**.

## PRODUCT RECORD

In the space below, record the date of purchase, model and serial number of your product. You will find the model and serial number printed on an identification label located on the right-hand side of the refrigerator compartment. Have these items of information available whenever you contact Sears concerning your product.

Model No. \_\_\_\_\_

Date of Purchase \_\_\_\_\_

Serial No. \_\_\_\_\_

Dealer \_\_\_\_\_

Save these instructions and attach your sales receipt for future reference.

# IMPORTANT SAFETY INSTRUCTIONS

This guide contains many important safety messages. Always **read and obey**.



This is the safety alert symbol. It alerts you to safety messages that inform you of hazards that can kill or hurt you or others, or cause damage to the product. All safety messages will be preceded by the safety alert symbol and the hazard signal word DANGER, WARNING, or CAUTION. These words mean:

**⚠ DANGER** You will be killed or seriously injured if you don't follow instructions.

**⚠ WARNING** You can be killed or seriously injured if you don't follow instructions.

**⚠ CAUTION** Indicates an imminently hazardous situation which, if not avoided, may result in minor or moderate injury, or product damage only.

All safety messages will identify the hazard, tell you how to reduce the change of injury and tell you what can happen if the instructions are not followed.

## ⚠ WARNING

**To reduce the risk of fire, electric shock or injury to persons when using your product, basic safety precautions should be followed, including the following. Read all instructions before using this appliance:**

- NEVER unplug your refrigerator by pulling on the power cord. Always grip the plug firmly and pull it straight out from the outlet.
- Repair or replace immediately all electric service cords that have become frayed or otherwise damaged. Do not use a cord that shows cracks or abrasion damage along its length or at either the plug or connector end.
- When moving your refrigerator away from the wall, be careful not to roll over or damage it in any way.
- Do not crush or damage the water line.
- Do not store or use gasoline or other flammable (vapors or liquids) in the vicinity of this or any other appliance.
- Do not allow children to climb, stand or hang on the refrigerator doors or shelves in the refrigerator. They could damage the refrigerator and seriously injure themselves.
- Keep fingers out of 'pinch point' areas; clearances between the doors and cabinet are necessarily small. Be careful when you open the doors when children are in the area.
- Unplug your refrigerator before cleaning or making any repairs.  
**NOTE:** We strongly recommend that any servicing be performed by a qualified individual.
- Before replacing a burned-out light bulb, unplug the refrigerator or turn off power at the circuit breaker or fuse box in order to avoid contact with a live filament. (A burned-out light bulb may break when being replaced).  
**NOTE:** Setting either or both controls to the OFF position does not remove power to the light circuit.
- Do not store bottles in the freezer compartment, they may break when frozen, causing damage.

- The refrigerator-freezer should be positioned so that supply plug is accessible for quick disconnection when accident happens.
- For personal safety, this appliance must be properly grounded. Have the wall outlet and the circuit checked by a qualified electrician to make sure the outlet is properly grounded.
- This refrigerator must be properly installed in accordance with the Attention Installer Instructions that were taped to the front of the refrigerator.
- After your refrigerator is in operation, do not touch the cold surfaces in the freezer compartment when hands are damp or wet. Skin may adhere to the extremely cold surfaces.
- In refrigerator with automatic icemakers, avoid contact with the moving parts of the ejector mechanism, or with the heating element that releases the cubes. DO NOT place fingers or hands on the automatic ice making mechanism while the refrigerator is plugged in.
- DO NOT refreeze frozen foods which have thawed completely. The United States Department of Agriculture in Home and Garden Bulletin No. 69 says: "...You may safely refreeze frozen foods that have thawed if they still contain ice crystals or if they are still cold below 40°F (4°C)."  
"Thawed ground meats, poultry, or fish that have any off-odor or off-color should not be frozen and should not be eaten. Thawed ice cream should be discarded. If the odor or color of any food is poor or questionable, get rid of it. The food may be dangerous to eat."  
"Even partial thawing and refreezing reduces the eating quality of foods, particularly fruits, vegetables and prepared foods. The eating quality of red meats is affected less than that of many other foods. Use refrozen foods as soon as possible to save as much of their quality as you can."

## SAVE THESE INSTRUCTIONS

## **⚠ DANGER: RISK OF CHILD ENTRAPMENT**

Child entrapment and suffocation are not problems of the past. Junked or abandoned refrigerators are still dangerous... even if they will sit for "just a few days". If you are getting rid of your old refrigerator, please follow the instructions at right to help prevent accidents.

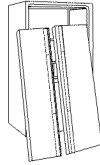

### **Before you throw away your old Refrigerator or freezer:**

- Take off the doors.
- Leave the shelves in place so that children may not easily climb inside.

## **CFC DISPOSAL**

Your old refrigerator may have a cooling system that used CFCs (chlorofluorocarbons). CFCs are believed to harm stratospheric ozone. If you are throwing away your old refrigerator, make sure the CFC refrigerant is removed for proper disposal by a qualified servicer. If you intentionally release this CFC refrigerant, you can be subject to fines and imprisonment under provisions

of environmental legislation. This appliance contains fluid (refrigerant, lubricant), and is made of parts and materials which are reusable and / or recyclable. All the important materials should be sent to the collection center of waste material and can be reused after rework (recycling). To recycle, please contact your local agency.

## **GROUNDING REQUIREMENTS**

**IMPORTANT:** Please read carefully.

### **TO CONNECT ELECTRICITY**

#### **⚠ WARNING**

##### **Electrical Shock Hazard**

**FOR PERSONAL SAFETY**, this appliance must be properly grounded. Have the wall outlet and the circuit checked by a qualified electrician to make sure the outlet is properly grounded.

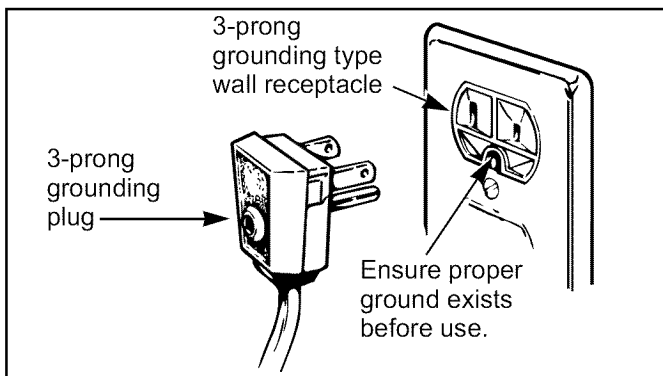

### **USE OF EXTENSION CORDS**

Because of potential safety hazards under certain conditions, we strongly recommend against the use of an extension cord. However, if you still elect to use an extension cord, it is absolutely necessary that it be a UL-listed (in the United States), 3-wire grounding type appliance extension cord having a grounding type plug and outlet, and that the electrical rating of the cord be 15 amperes (minimum) and 120 volts.

Use of an extension cord will increase the clearance needed for the back of the refrigerator. If the supply cord is damaged, it must be replaced by the manufacturer or its service agent or a similarly qualified person in order to avoid any hazard.

### **RECOMMENDED GROUNDING METHOD**

The refrigerator should always be plugged into its own individual properly grounded electrical outlet rated for 115 volts, 60Hz, AC only and fused at 15 or 20 amperes. This provides the best performance and also prevents overloading house wiring circuits which could cause a fire hazard from overheated wires. It is recommended that a separate circuit serving only this appliance be provided. Use a receptacle which cannot be turned off with a switch or pull chain. Do not use an extension cord.

Where a standard two-prong wall outlet is encountered, it is your personal responsibility and obligation to have it replaced with a properly grounded three-prong wall outlet. Do not, under any circumstances, cut or remove the third (Ground) prong from the power cord.

**NOTE:** Before performing any type of installation, cleaning, or removing a light bulb, turn the control (Thermostat, Refrigerator Control or Freezer Control, depending on the model) to OFF and then disconnect the refrigerator from the electrical source. When you are finished, reconnect the refrigerator to the electrical source and reset the control (thermostat, refrigerator control or freezer control, depending on the model) to the desired setting.

# REFRIGERATOR FEATURES

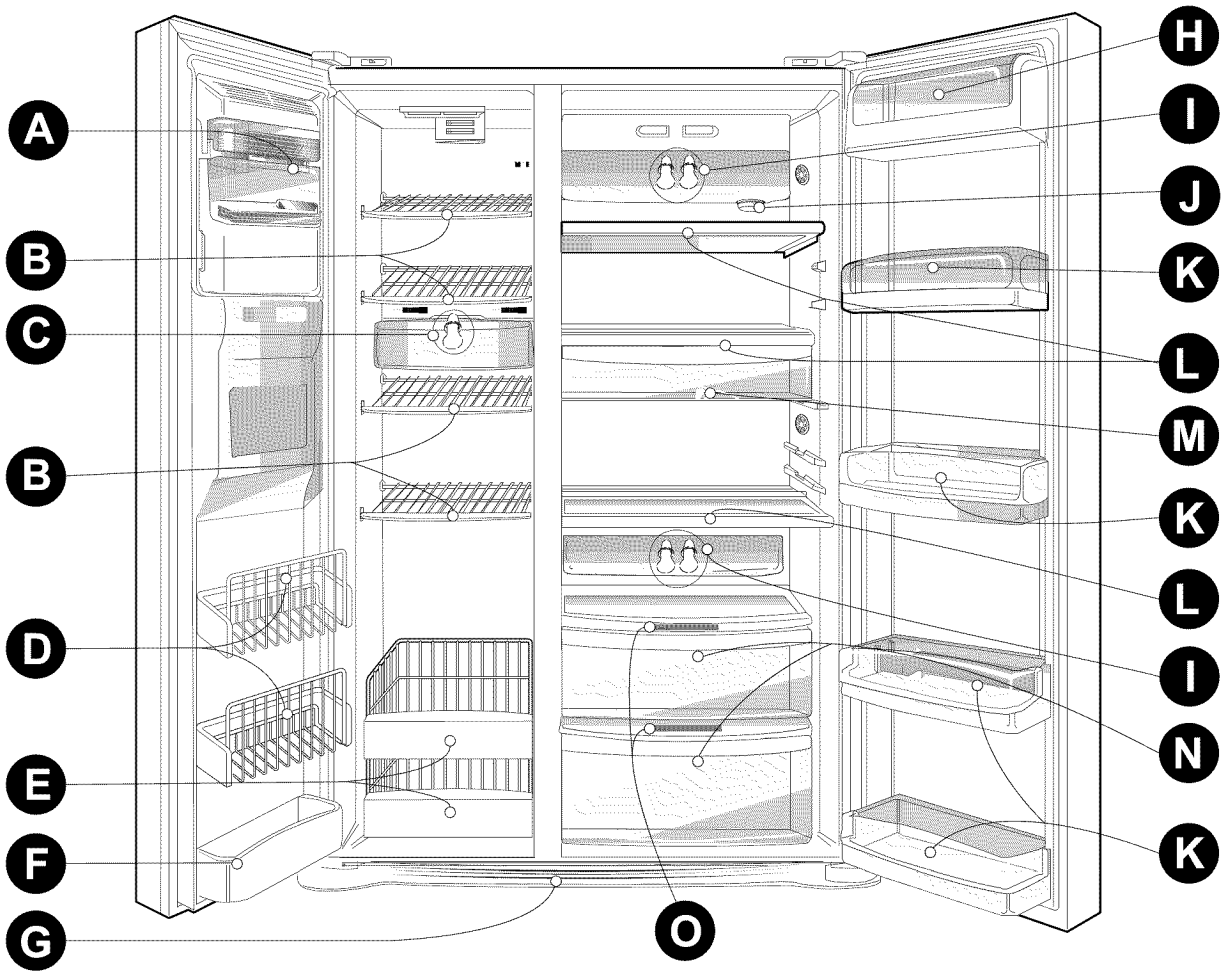

Use this page to become more familiar with the parts and features. Page references are included for your convenience.

**Note:** This guide covers several different models. The refrigerator you have purchased may have some or all of the items listed below. The locations of the features shown below may not match your model.

- A** Automatic Icemaker  
For storage of ice cubes made by the icemaker.  
Do not store anything except ice in the ice bin.
- B** Freezer Shelf (steel)
- C** Freezer Lamp
- D** Door Rack
- E** Drawer (Wire/Plastic)
- F** Freezer Door Rack
- G** Base Grille
- H** Dairy Corner  
For storage of dairy products  
such as butter and cheese.

- I** Refrigerator Lamp
- J** Water Filter
- K** Refrigerator Door Rack
- L** Refrigerator Shelf
- M** Snack Drawer  
For storage of meat or fresh food.
- N** Vegetable Drawer
- O** Humidity Control

# REFRIGERATOR INSTALLATION

## ⚠ WARNING

### Excessive Weight Hazard

Use two or more people to move and install refrigerator.  
Failure to do so can result in back or other injury.

## UNPACKING YOUR REFRIGERATOR

Remove tape and any temporary labels from your refrigerator before using. Do not remove any warning type labels or the model and serial number label.

To remove any remaining tape or glue, rub the area briskly with your thumb. Tape or glue residue can also be easily removed by rubbing a small amount of liquid dish soap over the adhesive with your fingers. Wipe with warm water and dry.

Do not use sharp instruments, rubbing alcohol, flammable fluids or abrasive cleaners to remove tape or glue. These products can damage the surface of your refrigerator. For more information, see the **Important Safety Instructions** section.

Refrigerator shelves are installed in the shipping position.

Please reinstall shelves according to your individual storage needs.

## ⚠ WARNING

### When Moving Your Refrigerator:

Your refrigerator is heavy. When moving the refrigerator for cleaning or service, be sure to protect the floor. Always pull the refrigerator straight out when moving it. Do not wiggle or walk the refrigerator when trying to move it, as floor damage could occur.

## ⚠ WARNING



### Explosion Hazard

Keep flammable materials and vapors, such as gasoline, away from refrigerator.

Failure to do so can result in death, explosion or fire.

## INSTALLATION

1. Avoid placing unit near heat sources, direct sunlight or moisture.
2. To minimize noise and vibration, the refrigerator **MUST** be installed on a solidly constructed floor.
3. Carpeting and soft tile surfaces are not recommended.
4. **NEVER** install the refrigerator on a platform or a weakly supported structure.
5. Install this appliance in an area where the temperature is between 41°F (5°C) and 110°F (43°C.) If the temperature around the appliance is too low or high, cooling ability may be adversely affected.

**NOTE:** For proper air circulation, best cooling and energy consumption results, maintain a minimum distance of 2 inches (5.08cm) from adjacent items and surfaces.

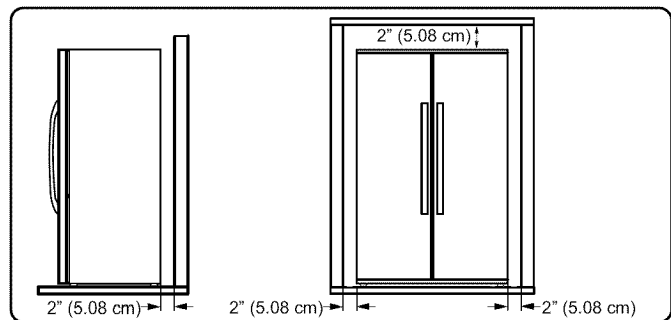

## ⚠ WARNING

- Be careful when you work with hinge, base grille, stopper, etc. You may be injured.
- Do not put hands or metal sticks into air vents, base grille or bottom of refrigerator. You may be injured or receive an electrical shock.

## BASE GRILLE INSTALLATION

### To install or replace base grille:

- Place cover into position and insert and tighten screws.

### To remove the base grille

1. Open the Doors. (Refrigerator and Freezer)
2. Once doors are open remove screws on top of cover.

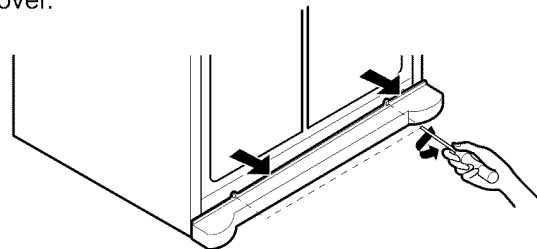

# REFRIGERATOR INSTALLATION

## LEVELING THE REFRIGERATOR DOOR

Place level on refrigerator shelf as shown below.

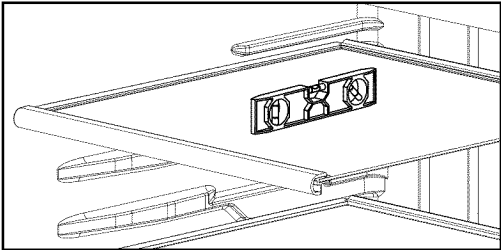
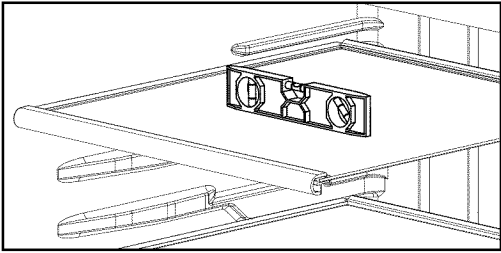

If your refrigerator is not level, insert a flat blade screwdriver into the grooves of the leveling legs (shown in picture below). Rotate legs clockwise to raise or counterclockwise to lower the front of the refrigerator.

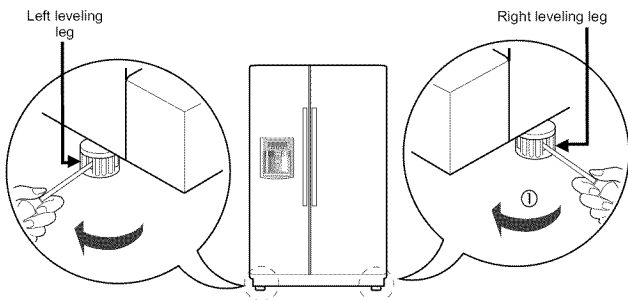

Raise the front of the refrigerator enough so the doors close freely when opened halfway. The refrigerator should slope 1/4" to 1/2" from front to back. Then level the refrigerator from side to side.

## HANDLE REMOVAL

**NOTE:** It is ALWAYS recommended to remove the refrigerator doors when it is necessary to move the refrigerator through a narrow opening. If necessary, follow the directions below to remove the door handles.

### Removing Refrigerator Handle

- Loosen the set screws with the 3/32" Allen wrench and remove the handle.

**NOTE:** If the handle mounting fasteners need to be tightened or removed, use a 1/4" Allen wrench.

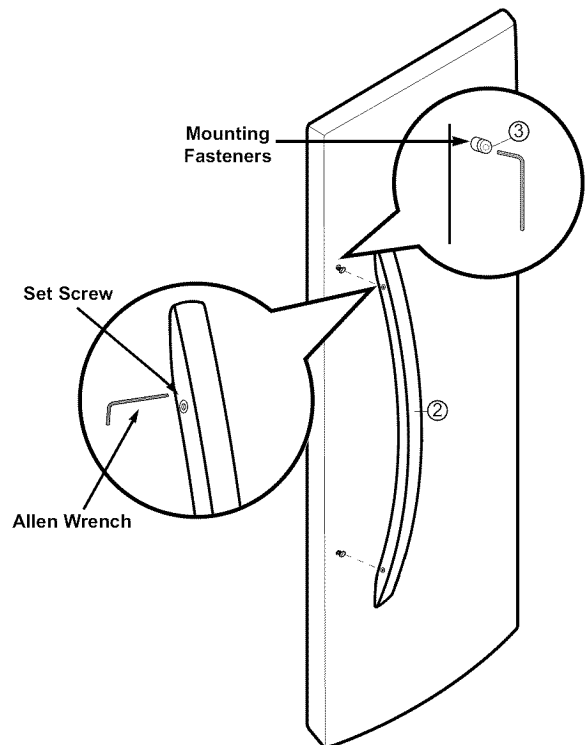

# REFRIGERATOR INSTALLATION

## ⚠ WARNING

### Electric Shock Hazard

- Disconnect electrical supply to the refrigerator before installing. Failure to do so could result in death or serious injury.
- Do not put hands or feet or other objects into the air vents, base grille, or bottom of the refrigerator. You may be injured or receive an electrical shock.
- Be careful when you work with the hinge, base grille, and stopper. You may be injured.

## REMOVING AND REPLACING REFRIGERATOR DOORS

Before removing the doors, remove the Base Grille. See **BASE GRILLE INSTALLATION** for reference.

### Removing the right (refrigerator) door.:

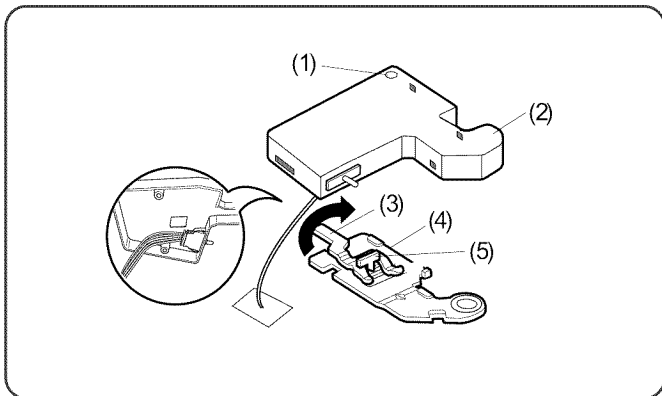

1. Open the door. Remove the top hinge cover screw (1).
2. Use a flat-head screwdriver to pry back the hooks (not shown) on the cabinet underside of the cover (2). Lift up the cover.
3. Rotate the hinge lever (3) clockwise. Lift the top hinge (4) free of the hinge lever latch (5).
4. Lift the door from the lower hinge pin.
5. Place the door inside up on a nonscratching surface.

**⚠ CAUTION:** When lifting the hinge free of the latch, be careful that the door does not fall forward.

### Removing the left (freezer) door with water line connection.

- Remove the Locking Clip from connector (figure 1).
- Pull up the water feed tube while pressing area (figure 2) as shown in the figures below.
- **NOTE:** If the water tube end is deformed or abraded, trim the part away. Disconnecting the water tube under the door causes about 1.5 liters of water to flow out. Put a large container at end of tube to prevent water from draining onto the floor.

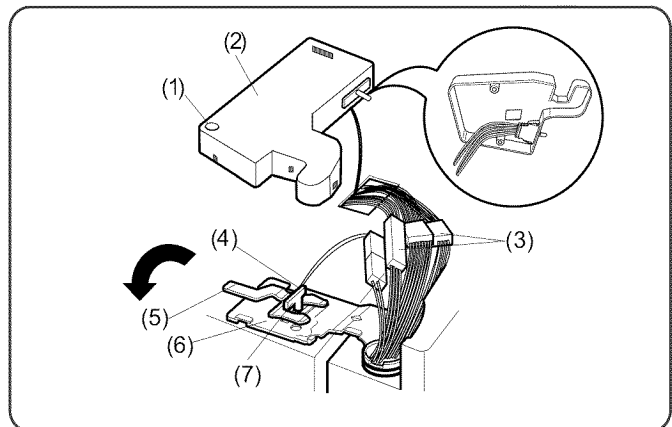
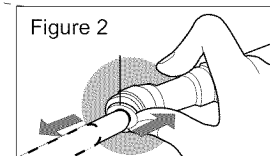
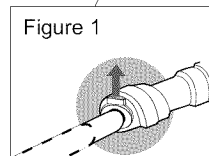
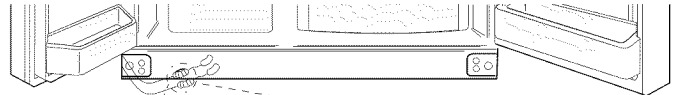

1. Open the door. Remove the top hinge cover screw (1).
2. Use a flat blade screwdriver to pry back the hooks (not shown) on the cabinet underside of the cover (2). Lift up the cover.
3. Disconnect all the wire harnesses (3).
4. Remove the grounding screw (4).
5. Rotate hinge lever (5) counterclockwise. Lift the top hinge (6) free of the hinge lever latch (7).

**⚠ CAUTION:** When lifting the hinge free of the latch, be careful that the door does not fall forward.

6. Lift the door from the lower hinge pin being careful to pull the water line through the lower hinge pin.
7. Place the door, inside facing up, on a nonscratching surface.

# REFRIGERATOR INSTALLATION

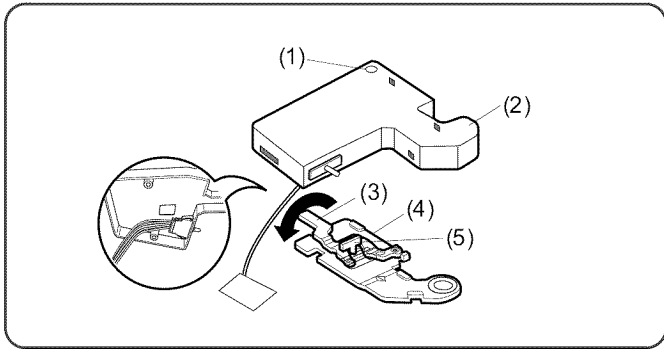

## Reinstalling the right (Refrigerator) door

### ► Right Door

1. Place the door onto the lower hinge pin.
2. Fit top hinge (5) over hinge lever latch (6) and into place. Rotate lever (4) counterclockwise to secure hinge.
3. Rotate the hinge lever (3) clockwise. Lift the top hinge (4) free of the hinge lever latch (5).
4. Hook tab on switch side of corner under edge of wire opening in cabinet top. Position cover (2) into place. Insert and tighten cover screw (1).

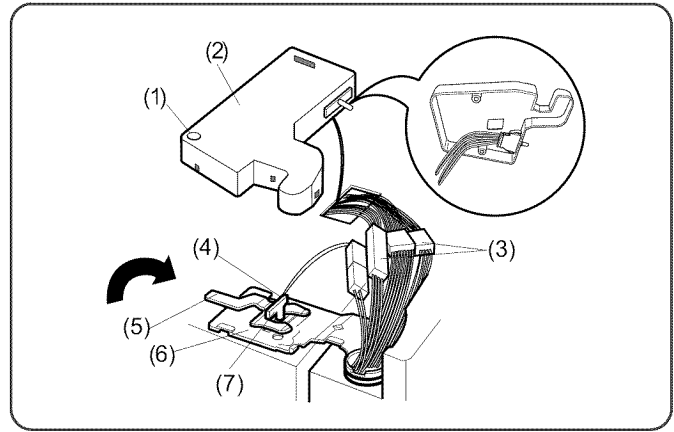

### ► Reinstalling the right (Freezer) door

1. Feed the water tube through the lower hinge pin and place the door onto the lower hinge pin.
2. Fit top hinge (6) over hinge lever latch (7) and into place. Rotate lever (5) clockwise to secure hinge.
3. Install the grounding screw (4) and connect all the wire harnesses (3).
4. Hook tab on door switch side of cover (2) under edge of wire opening in cabinet top. Position cover into place. Insert and tighten cover screw (1).
5. Reconnect the water tubing by inserting the tube into the connector and reinstalling the lockin clip.

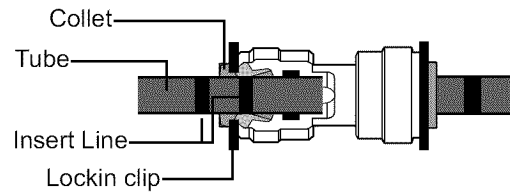

# REFRIGERATOR INSTALLATION

## DOOR ALIGNMENT

**NOTE:** If after leveling the refrigerator (see LEVELING THE REFRIGERATOR) the doors are still misaligned follow the directions below.

Before adjusting the doors, remove the Base Grille. See **BASE GRILLE INSTALLATION** for reference.

If the freezer compartment door is lower than the refrigerator compartment door, align them by inserting a flat blade screwdriver into the groove of the left leveling leg and rotating it clockwise.

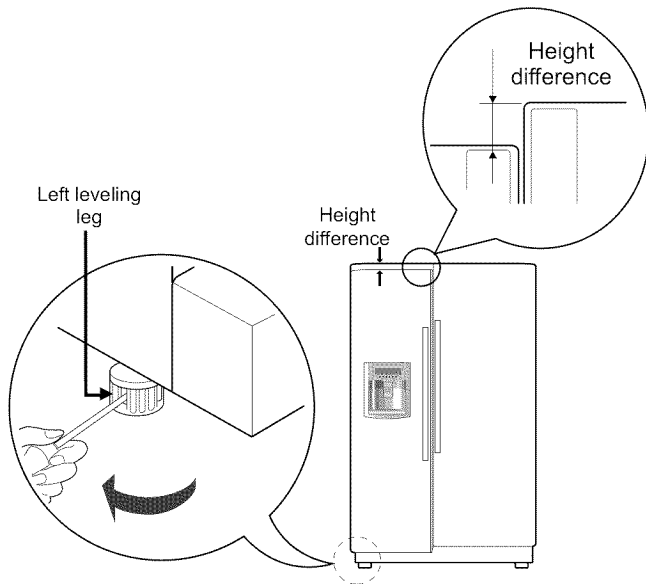

If the freezer compartment door is higher than the refrigerator compartment door, align them by inserting a flat blade screwdriver into the groove of the right leveling leg and rotating it clockwise.

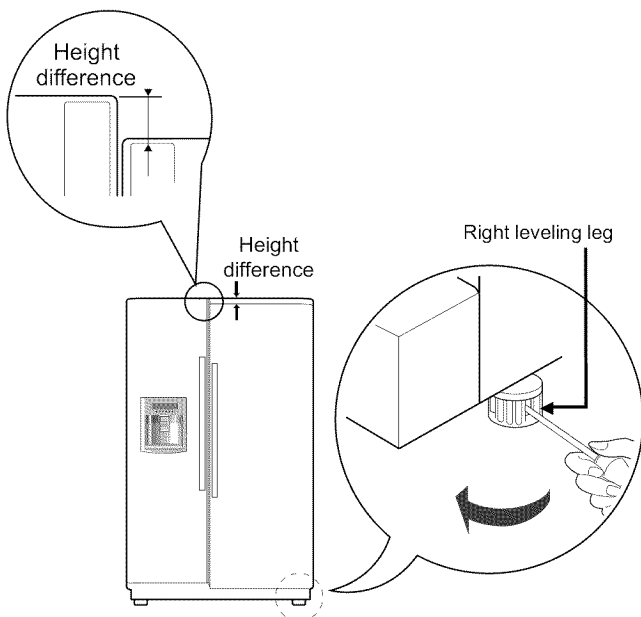

## ADDITIONAL ADJUSTMENT

If rotating the leveling legs does not result in satisfactory door alignment, you may fine tune the alignment by adjusting the right door adjustment hinge pin.

### Tools you need

- Wrench 5/16 in (8 mm)

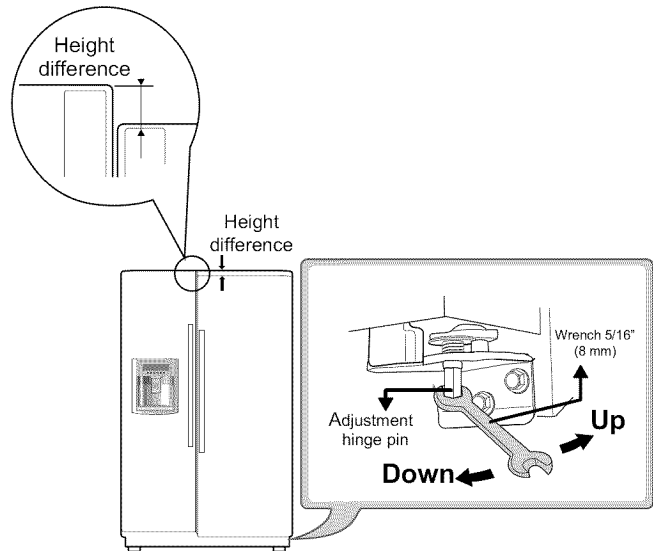

Using a 5/16 in (8mm) wrench, turn the adjustment hinge pin clockwise or counterclockwise to align the refrigerator with the freezer door.

Do not over tighten the door adjustment pin. The hinge pin can be pulled out. (Adjustable range of height is a maximum of 1/2" (1.27 cm)).

## AFTER LEVELING THE DOOR HEIGHT

Make sure the front leveling legs are completely touching the floor.

# USING YOUR REFRIGERATOR

## ENSURING PROPER AIR CIRCULATION

In order to ensure proper temperatures, air must flow between the refrigerator and freezer sections. As shown in the illustration below, cool air enters through the refrigerator of the freezer section and moves up. Most of the air then flows through the freezer section vents and recirculates under the freezer floor. The rest of the air enters the refrigerator section through the top vent.

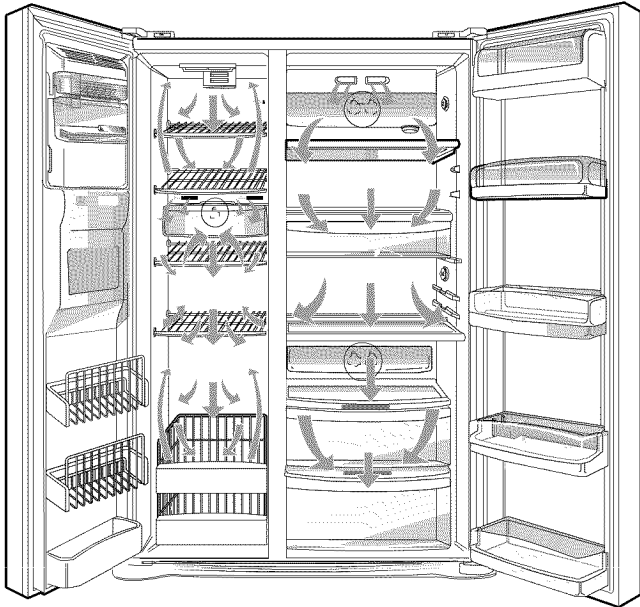

- **Do not block any of these vents** with food packages. If the vents are blocked, airflow will be interrupted and temperature and moisture problems may occur.

### IMPORTANT:

Because air circulates between both sections, any odors formed in one section will transfer to the other. You must thoroughly clean both sections to eliminate odors. To prevent odor transfer and drying out food, wrap or cover food tightly. (See the Food Storage Guide section for details.)

**Note:** If you close the refrigerator forcefully, the freezer door may open and close again due to pressure from internal air flow.

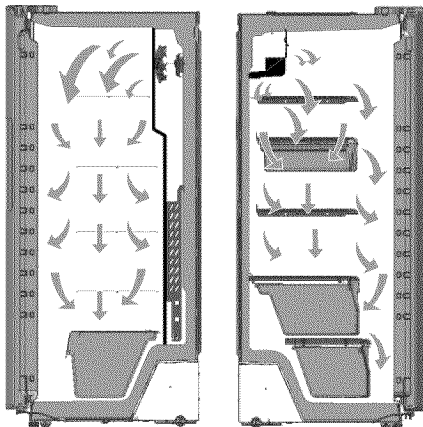

## NEXT

1. Clean your refrigerator thoroughly and wipe off dust accumulated during shipping.
2. Install accessories such as ice cube bin, drawers, shelves, etc., in their proper places. They are packed together to prevent possible damage during shipment.
3. Let your refrigerator run for at least 2 or 3 hours before putting food in it. Check the flow of cold air in the freezer compartment to ensure proper cooling. Your refrigerator is now ready for use.

## SETTING THE CONTROL

Your refrigerator has a control pad on the dispenser that lets you regulate the temperature in the freezer and refrigerator compartments.



## REFRIGERATOR AND FREEZER CONTROLS

The refrigerator control is preset at 37°F (3°C) and the freezer control is preset at 0°F (-18°C).

These are the recommended temperature settings for normal use and conditions.



Wait 24 hours for the refrigerator and freezer to reach these temperatures.

To adjust temperatures, press the Ref Temp button or the Frz Temp button to the desired temperature.

- The Refrigerator Temp Control range is from 33°F to 46°F (0°C to 8°C). The lower the number setting, the colder the refrigerator compartment will become.
- The Freezer Temp Control range is from -6°F to 8°F (-21°C to -13°C). When the setting is at a lower number, the freezer compartment becomes colder.

**NOTE:** When changing control settings, wait 24 hours before making additional adjustments. After 24 hours, adjust the compartments temperatures as desired.

### Temperature Mode Switch Function (°F to °C)

If you want to convert °F to °C or vice versa, press and hold  button and  button simultaneously for 5 seconds or until it changes.

# USING YOUR REFRIGERATOR

## Dispenser Light

Press dispenser light  button to turn the dispenser light ON or OFF.

## Door Alarm

Press the door alarm  button to turn the door alarm ON or OFF. When you close the door, the door alarm will stop.

When either refrigerator or the freezer door is left open for more than 60 seconds, the alarm will ding to let you know the door is open.

## Lock

The Lock button  deactivates the temperature controls and dispenser functions.

Press and hold  button for 3 seconds or until the Lock indicator light is lit.

To disable the Lock function, press and hold  button for 3 seconds or until the Lock indicator light is off.

## Ultra Ice

When you press the “Ultra Ice” button, the graphic  will light up in the display and it continues for 24hours. It will automatically shut of after 24 hours have passed.

Or you can stop this function manually by pressing the button one more time. This function increases both icemaking and freezing capabilities.

## Dispenser selection

You can select water or ice.

- Select Water, Crushed Ice or Cubed Ice by pressing the  button to the selection desired.

To dispense water or ice, gently push your cup against the dispenser pad.

**NOTE:** Hold your cup in place for a couple of seconds after dispensing water or ice so that the last few drops or fragments go in your cup instead of on the floor.

# USING YOUR REFRIGERATOR

## ADJUSTING CONTROL SETTINGS

Give the refrigerator time to cool down completely before making final adjustments. It is best to wait 24 hours before doing this. The initial settings mentioned in SETTING THE CONTROLS section should be correct for normal household refrigerator use. The controls are set correctly when milk or juice is as cold as you like and when ice cream is firm.

The refrigerator control functions as the thermostat for the entire appliance (refrigerator and freezer sections). The higher the number setting, the longer the compressor will run to keep the temperature colder. The freezer control adjusts the cold air flow from the freezer to the refrigerator. Setting the freezer control to a lower temperature keeps more cold air in the Freezer compartment to make it colder.

If you need to adjust temperatures in the refrigerator or freezer, start by adjusting the refrigerator. Then wait 24 hours before checking the freezer temperature. If it is too warm or too cold, then adjust the freezer control.

Use the settings listed in the chart below as a guide. **Always remember to wait at least 24 hours between adjustments.**

CONDITION/ REASON :	RECOMMENDED ADJUSTMENT :
<p>■ REFRIGERATOR section too warm</p> <ul style="list-style-type: none"> <li>– Door opened often</li> <li>– Large amount of food added</li> <li>– Room temperature very warm</li> </ul>	Turn REFRIGERATOR control to next highest number; wait 24 hours to reach new temperature.
<p>■ FREEZER section too warm/ice not made fast enough</p> <ul style="list-style-type: none"> <li>– Door opened often</li> <li>– Large amount of food added</li> <li>– Very cold room temperature (Compressor doesn't cycle often enough)</li> <li>– Heavy ice usage</li> <li>– Air vents blocked by items</li> </ul>	Turn FREEZER control to next highest number; wait 24 hours to reach new temperature.  Move items out of airstream
<p>■ REFRIGERATOR section too cold</p> <ul style="list-style-type: none"> <li>– Controls not set correctly for your conditions</li> </ul>	Set REFRIGERATOR control to next lower number; wait 24 hours to reach new temperature.
<p>■ FREEZER section too cold</p> <ul style="list-style-type: none"> <li>– Controls not set correctly for your conditions</li> </ul>	Set FREEZER control to next lower number; wait 24 hours to reach new temperature.

## FOOD STORAGE GUIDE

Wrap or store food in the refrigerator in airtight and moisture-proof material unless otherwise noted. This prevents food odor and taste transfer throughout the refrigerator. For dated products, check date code to ensure freshness.

Items	How to
<b>Butter or margarine</b>	► Keep opened butter in a covered dish or closed compartment. When storing an extra supply, wrap in freezer packaging and freeze.
<b>Cheese</b>	► Store in the original wrapping until you are ready to use it. Once opened, rewrap tightly in plastic wrap or aluminum foil.
<b>Milk</b>	► Wipe milk cartons. For best storage, place milk on interior shelf, not on door shelf.
<b>Eggs</b>	► Store in original carton or Utility Bin on interior shelf, not on door shelf.
<b>Fruit</b>	► Wash, let dry, and store in refrigerator in plastic bags or in the crisper. Do not wash or hull berries until you are ready to use them. Sort and keep berries in their original container in a crisper, or store in a loosely closed paper bag on a refrigerator shelf.
<b>Leafy vegetables</b>	► Remove store wrapping and trim or tear off bruised and discolored areas. Wash in cold water and drain. Place in plastic bag or plastic container and store in crisper.
<b>Vegetables with skins (carrots, peppers)</b>	► Place in plastic bags or plastic container and store in crisper.
<b>Fish</b>	► Use fresh fish and shellfish the same day purchased.
<b>Leftovers</b>	► Cover leftovers with plastic wrap or aluminum foil. Plastic containers with tight lids can also be used.

# USING YOUR REFRIGERATOR

## STORING FROZEN FOOD

**NOTE:** For further information about preparing food for freezing or food storage times, check a freezer guide or a reliable cookbook.

### Packaging

Successful freezing depends on correct packaging. When you close and seal the package, it must not allow air or moisture in or out. If it does, you could have food odor and taste transfer throughout the refrigerator and also dry out frozen food.

### Packaging recommendations:

- Rigid plastic containers with tight-fitting lids
- Straight-sided canning/freezing jars
- Heavy-duty aluminum foil
- Plastic-coated paper
- Non-permeable plastic wraps
- Special freezer-grade self-sealing plastic bags

Follow package or container instructions for proper freezing methods.

### Do not use

- Bread wrappers
- Non-polyethylene plastic containers
- Containers without tight lids
- Wax paper or wax-coated freezer wrap
- Thin, semi-permeable wrap

**⚠ CAUTION:** Do not keep beverage cans or plastic food containers in the freezer compartment. They may break if they freeze.

### Freezing

Your freezer will not quick-freeze any large quantity of food. Do not put more unfrozen food into the freezer than will freeze within 24 hours (no more than 2 to 3 lbs of food per cubic foot of freezer space). Leave enough space in the freezer for air to circulate around packages. Be careful to leave enough room at the front so the door can close tightly.

Storage times will vary according to the quality and type of food, the type of packaging or wrap used (airtight and moisture-proof) and the storage temperature. Ice crystals inside a sealed package are normal. This simply means that moisture in the food and air inside the package have condensed, creating ice crystals.

**NOTE:** Allow hot foods to cool at room temperature for 30 minutes, then package and freeze. Cooling hot foods before freezing saves energy.

## WATER DISPENSER

- Tray can be easily removed by pressing and pulling it.

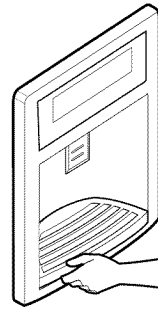

- Tilt up the front of tray slightly and snap the tabs into the holes to reinstall the tray.

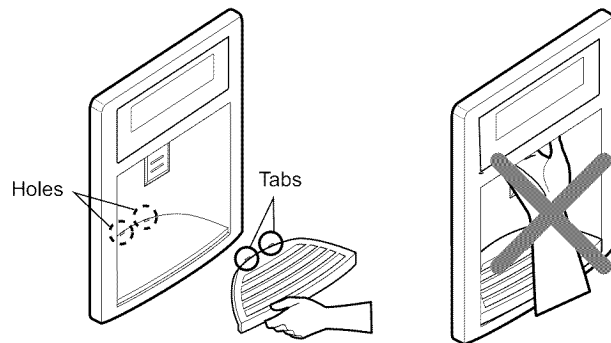

## ⚠ WARNING

Do not put your hands into the water & ice dispenser opening. Doing so may cause an injury to your hand.

# USING YOUR REFRIGERATOR

## REFRIGERATOR SHELVES

The refrigerator compartment shelf is adjustable so that you can place it at a height according to space requirement of foods.

### • Slide shelf

Pull the shelf ahead, then lift both front and rear while taking out.

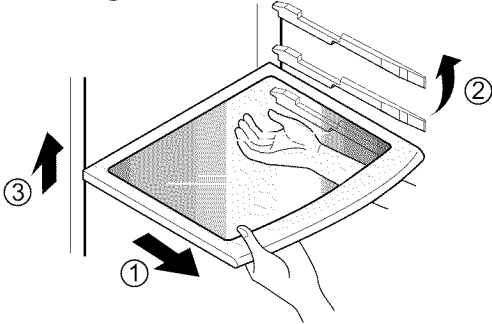

### NOTE

Make sure to keep shelf horizontal while removing; otherwise it may drop.

### • Fixed shelf

Lightly lift up the front part of shelf to pull it ahead, then take it out while lifting the rear part of shelf.

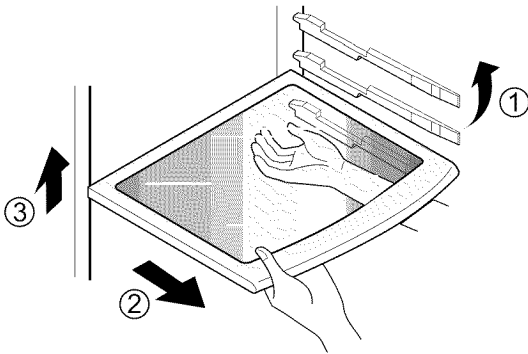

## CRISPER AND CRISPER COVER

To remove the crisper compartment cover, pull out the crisper compartment a bit to the front ①, lift the front part of the cover as shown by ②, and take it out.

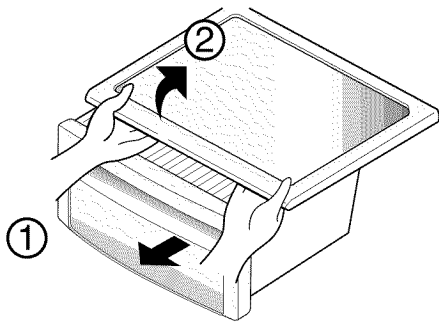

## FREEZER COMPARTMENT SHELF

To remove a shelf, lift the left part of the shelf a bit. Lift it to the direction ①, push the right part to the direction ②, and take it out.

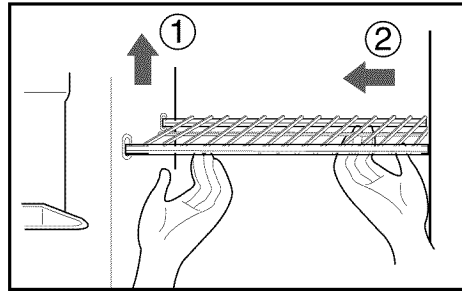

## DOOR RACK AND SUPPORT

Lift the door rack holding both sides ① and pull it out to ② direction.

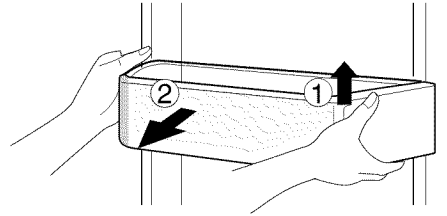

## ICE STORAGE BIN

Hold the ice storage bin as shown in the right figure ② and pull it out while slightly lifting it ①.

- Do not disassemble the ice storage bin unless it is necessary.
- Use both hands to remove the ice bin to avoid dropping it.

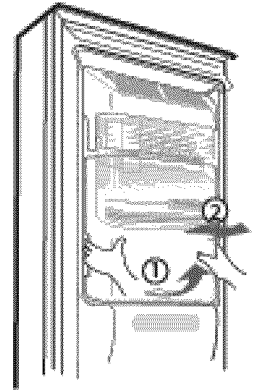

# USING YOUR REFRIGERATOR

## WATER FILTER

• Filter Reset: When the FILTER RESET icon turns on, you have to change the water filter. Press the FILTER RESET button for 3 seconds to turn the icon .

You need to change the water filter approximately every 6 months.

### Before removing or installing water filter

1. Take out the top shelf and move it to the lowest level.
2. Remove the lamp cover by pressing the tab under the cover and pulling cover to the front.
3. **IMPORTANT:** Turn off household water supply

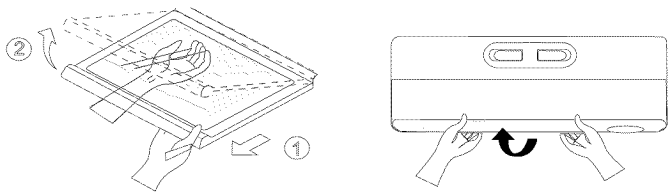

### Removing the water filter:

1. For first-time installation, remove filter substitute cap ① by turning it counterclockwise a quarter turn and pulling it down. **The substitute cap must be retained for the future. If the filter is removed and not replaced, it is necessary to reinstall the substitute cap to prevent water leaks from the filter housing.**
2. For subsequent installation, remove old filter by slowly turning it to the left a quarter turn and pulling it down.

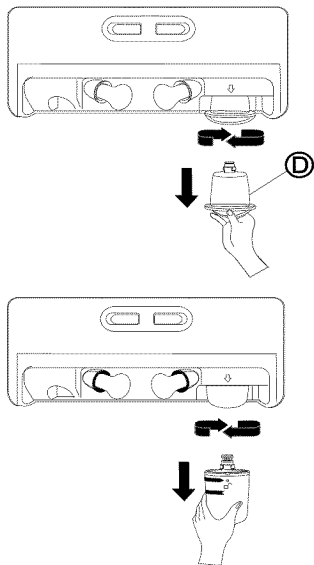

### Installing the water filter

Remove red cap from the filter and insert the two tabs on the filter tip into the two slots in the refrigerator filter receptacle. Turn the filter to the right a quarter turn to lock it into place. The locked symbol will be lined up with the indicator arrow.

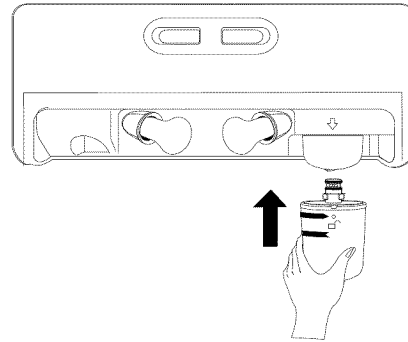

### After installing water filter

- a) Replace the cover lamp and shelf to the initial position.
- b) After installing filter, turn on household water supply.
- c) Dispense at least 1 gallon of water to purge trapped air from the system. Open the refrigerator door and check the shelf area for leaks.

To purchase replacement water filters, call 1-800-4-MY-HOME and ask for replacement part no. 5231JA2002B

# USING YOUR REFRIGERATOR

## Performance Data Sheet Models Number 5231JA2002B-S

Use with replacement cartridge 5231JA2002B

This system has been tested according to NSF/ANSI Standards 42 for the reduction of the substances listed below. The concentration of the indicated substances in water entering the system was reduced to a concentration less than or equal to the permissible limit for water leaving the system as specified in NSF/ANSI 42.



System tested and certified by NSF International against NSF/ANSI Standard 42 for the reduction of Chlorine Taste and Odor and Nominal Particulate Class III.

Capacity: 500 gal (1,892 L)

Substance	Average Influent Concentration	Influent Challenge Concentration. Units apply to each row	Avg. Product Water Concentration	Average % Reduction	NSF % reduction req. or Max. permissible product water concentration
Nominal Particulate Class I Particle size: >0.5 to <1um	24,333	At least 10,000 particles/ml	915	96	≥ 85%
Chlorine taste and odor Class III	1.9	2.0 mg/L ±10%	0.07	96.4	≥ 50%

Note that while the testing was performed under standard laboratory conditions, actual performance may vary.

Application Guidelines/Water Supply Parameters	
Service flow	0.5 gpm ( 1.89 lpm)
Water pressure	20 - 125 psi (138 - 862 kPa)
Water temperature	33°F - 100°F (0.6°C - 38°C)

### WARNING

To reduce the risk associated with ingestion of contaminants due to use with water that is microbiologically unsafe or of unknown quality. Do not use with water that is microbiologically unsafe or of unknown quality without adequate disinfection before or after the system.

### CAUTION

To reduce the risk of property damage due to water leakage:

- Read and follow Use instructions before installation and use of this system.
- Install on COLD water lines only.
- Comply with all state and local plumbing codes.
- Install a pressure limiting device and water hammer arrester for inlet water pressures exceeding 80 psi (552 kPa). Refer to Uniform Plumbing Code, Sections 608.2 and 609.10.
- Never install or operate where inlet water pressure may exceed 120 psi (827 kPa).
- Protect filter from freezing. Remove filter in temperatures below 33°F (0.6°C).
- Replace cartridge at specified service interval. Cartridge MUST be replaced at least every 12 months.

To purchase a replacement filter, visit your local Sears store or call 1-800-4-MYHOME®. Visit us on the web at [www.sears.com](http://www.sears.com)

Systems must be installed and operated in accordance with manufacturer's recommended procedures and guidelines.

Warranty: See Warranty Card for Details.

Distributed by:  
Sears Brand Management Corporation  
3333 Beverly Road  
Hoffman Estates, IL 60179

## CARE AND CLEANING

### ⚠ WARNING



#### Explosion Hazard

Use non-flammable cleaner.

Failure to do so can result in death, explosion, or fire.

Both the refrigerator and freezer sections defrost automatically. However, clean both sections about once a month to prevent odors. Wipe up spills immediately.

### GENERAL CLEANING TIPS

- Unplug refrigerator or disconnect power.
- Remove all removable parts, such as shelves, crispers, etc. Refer to sections in Using Your Refrigerator for removal instructions.
- Use a clean sponge or soft cloth and a mild detergent in warm water. Do not use abrasive or harsh cleaners.
- Hand wash, rinse and dry all surfaces thoroughly.
- Plug in refrigerator or reconnect power.

### OUTSIDE

Waxing external painted metal surfaces helps provide rust protection. Do not wax plastic parts. Wax painted metal surfaces at least twice a year using appliance wax (or auto paste wax). Apply wax with a clean, soft cloth.

Do not use wax on stainless steel exteriors. Use a product specially designed for polishing stainless steel appliances, or clean with a soft cloth or clean sponge and a mild detergent dissolved in warm water. Dry thoroughly with a soft cloth.

**NOTE:** Avoid door surface contact with chemical products that contain Phosphate or Chlorine.

### INSIDE WALLS (allow freezer to warm up so cloth won't stick)

To help remove odors, you can wash the inside of the refrigerator with a mixture of baking soda and warm water. Mix 2 tablespoons baking soda to 1 quart of water (26 g soda to 1 litre water.) Be sure the baking soda is completely dissolved so it does not scratch the surfaces of the refrigerator.

### DOOR LINERS AND GASKETS

Do not use cleaning waxes, concentrated detergent, bleaches, or cleaners containing petroleum on plastic refrigerator parts.

Use a clean sponge or soft cloth and a mild detergent in warm water. Wash, rinse and dry all surfaces thoroughly.

### PLASTIC PARTS (covers and panels)

Do not use windows sprays, abrasive cleaners, or flammable fluids. These can scratch or damage the material. Use a clean sponge or soft cloth and a mild detergent in warm water. Wash, rinse and dry all surfaces thoroughly.

### BACK COVER

### ⚠ WARNING

#### ELECTRICAL SHOCK HAZARD

Before you begin, either unplug the refrigerator or turn off power at the circuit breaker or fuse box.

Failure to do so could result in death or serious injury.

**NOTE:** Back cover should only be removed by a qualified technician.

Clean the vents on the back cover. Use a vacuum cleaner with the brush attachment, at least twice a year to keep your refrigerator working efficiently.

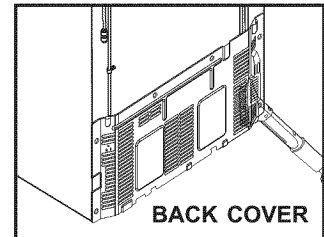

### ⚠ WARNING

#### Electrical Shock Hazard

Before replacing a burned-out light bulb, either unplug the refrigerator or turn off power at the circuit breaker or fuse box.

**NOTE:** Not all appliance bulbs will fit your refrigerator. Be sure to replace the bulb with one of the same size, shape and wattage.

## CARE AND CLEANING

### To change the refrigerator light:

Remove cover by pressing upward on bottom ① and rotating outward ② turn the bulb counterclockwise. Replace with 40 watt (maximum) appliance bulb.

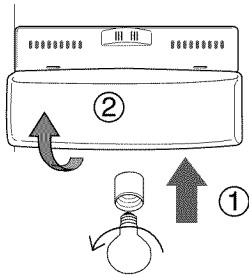

To remove the lamp cover, press the protrusion under the lamp cover to the front and then pull the lamp cover out. Turn the bulb counterclockwise. max. 40 W bulb for refrigerator is used and can be purchased at a service center.

## POWER INTERRUPTIONS

1. If the power will be out for 24 hours or less, keep all refrigerator doors closed to help foods stay cold and frozen.
2. If the power will be out for more than 24 hours:
  - a) Remove all frozen food and store it in a frozen food locker.

### OR

- b) Place 2 lbs. (ca 1kg) of dry ice in the freezer for every cubic foot (28 L) of freezer space. This will keep the food frozen for two to four days. While handling dry ice, wear gloves to protect your hands from frostbite.

## ⚠ WARNING

### Suffocation Hazard

When using dry ice, provide adequate ventilation. Dry ice is frozen carbon dioxide ( $\text{CO}_2$ ). When it vaporizes, it can displace oxygen, causing dizziness, light-headedness, unconsciousness and death by suffocation. Open a window and do not breathe the vapors.

### OR

- c) If neither a food locker nor dry ice is available, consume or dispose of food at once.

**REMEMBER:** In a power failure, a full freezer stays cold longer than a partially filled one. If you see that food contains ice crystals, it may be affected. If the condition of the food is poor, or if you feel it is unsafe, dispose of it.

## ⚠ WARNING

- **DO NOT** refreeze frozen foods which have thawed completely.  
The United States Department of Agriculture in Home and Garden Bulletin No. 69 says:  
...You may safely refreeze frozen foods that have thawed if they still contain ice crystals or if they are still cold-below 4°C.  
...Thawed ground meats, poultry or fish that have any off-odor or off-color should not be frozen and should not be eaten.  
Thawed ice cream should be discarded. If the odor or color of any food is poor or questionable, dispose of it. The food may be dangerous to eat.  
Even partial thawing and refreezing reduces the eating quality of foods, particularly fruits, vegetables and prepared foods.  
The eating quality of red meats is affected less than that of many other foods. Use refrozen foods as soon as possible to save as much of their quality as you can.

## WHEN YOU GO ON VACATION

If you choose to leave the refrigerator **ON** while you are away, follow these steps to prepare your refrigerator before you leave.

1. Use up any perishables and freeze other items.
2. Empty the ice bin.
3. Turn OFF the Icemaker. **NOTE:** If the ambient temperature will drop below freezing, have a qualified service technician drain the water supply system (on some models) to prevent serious property damage due to possible flooding from ruptured water lines or connections.

If you choose to turn the refrigerator **OFF** before you leave, follow these steps.

1. Remove all food from the refrigerator and empty ice bin.
2. Unplug refrigerator.
3. Clean refrigerator, wipe, and dry well.
4. Tape rubber or wood blocks to the tops of both doors to prop them open far enough for air to get in. This stops odor and mold from building up.

## WHEN YOU MOVE

When you are moving your refrigerator to a new home, follow these steps to prepare it for the move.

1. Remove all food from the refrigerator and pack all frozen food in dry ice.
2. Unplug refrigerator.
3. Clean refrigerator, wipe, and dry well.
4. Empty water from the defrost pan.
5. Clean, wipe and dry thoroughly.
6. Take out all removable parts, wrap them well and tape together so they don't shift and rattle during the move. Refer to sections in Using your Refrigerator for removal instructions.

## CARE AND CLEANING

- Depending on the model, raise the front of the refrigerator so it rolls more easily OR screw in the levelling legs all the way so they don't scrape the floor. See the **LEVELLING AND DOOR CLOSING** section.
- Tape the doors shut and tape the power cord to the refrigerator cabinet.

When you get to your new home, put everything back and refer to the **REFRIGERATION INSTALLATION** section for setup instructions.

### ICEMAKER OPERATION

#### **⚠ WARNING**

##### **Personal Injury Hazard**

Avoid contact with the moving parts of the icemaker ejector mechanism, or with the heating element that releases the cubes. **DO NOT** place fingers or hands on the automatic icemaking mechanism while the refrigerator is plugged in.

**A newly-installed refrigerator may take 12 to 24 hours to begin making ice.**

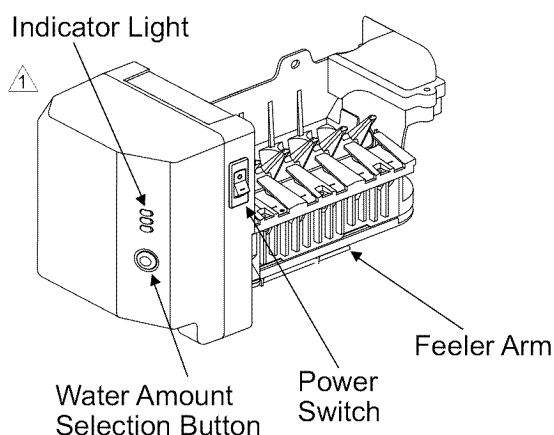

The icemaker will produce 6 cubes per cycle approximately 90-110 cubes in a 24-hour period, depending on freezer compartment temperature, room temperature, number of door openings and other operating conditions.

If the refrigerator is used before the water connection is made to the icemaker, set the power switch to **O (off)**.

When the refrigerator has been connected to the water supply, set the power switch to **I (on)**.

The icemaker will fill with water when it cools to freezing. A newly-installed refrigerator may take 12 to 24 hours to begin making ice cubes.

Throw away the first few batches of ice to allow the water line to clear.

Be sure nothing interferes with the sweep of the feeler arm.

When the bin fills to the level of the feeler arm, the icemaker will stop producing ice.

It is normal for several cubes to be stuck together.

If ice is not used frequently, old ice cubes will become cloudy, taste stale, and shrink.

#### **WHEN YOU SHOULD SET THE ICEMAKER POWER SWITCH TO OFF**

- When the water supply will be shut off for several hours.
- When the ice storage bin is removed for more than a minute or two.
- When the refrigerator will not be used for several days.

#### **NORMAL SOUNDS YOU MAY HEAR**

- The icemaker water valve will buzz as the icemaker fills with water. If the power switch is in the **I (on)** position, it will buzz even if it has not yet been hooked up to water. To stop the buzzing, move the power switch to **O (off)**.

**NOTE:** Keeping the power switch in the **I (on)** position before the water line is connected can damage the icemaker.

- You will hear the sound of cubes dropping into the bin and water running in the pipes as the icemaker refills.

# CONNECTING THE WATER LINE

## BEFORE YOU BEGIN

This water line installation is not warranted by the refrigerator or icemaker manufacturer. Follow these instructions carefully to minimize the risk of expensive water damage.

Water hammer (water banging in the pipes) in house plumbing can cause damage to refrigerator parts and lead to water leakage or flooding. Call a qualified plumber to correct water hammer before installing the water supply line to the refrigerator

To prevent burns and product damage, do not hook up the water line to the hot water line.

If you use your refrigerator before connecting the water line, make sure the icemaker power switch is in the **O (off)** position.

Do not install the icemaker tubing in areas where temperatures fall below freezing.

When using any electrical device (such as a power drill) during installation, be sure the device is double-insulated or grounded in a manner to prevent the hazard of electric shock, or is battery-powered.

All installations local must be in accordance with plumbing code requirements.

**NOTE:** Wear eye protection.

## WHAT YOU WILL NEED

- **Copper Tubing**, 1/4" outer diameter to connect the refrigerator to the water supply. Be sure both ends of the tubing are cut square.

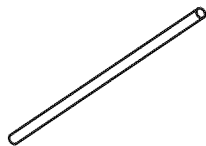

To determine how much tubing you need: measure the distance from the water valve on the back of the refrigerator to the water supply pipe. Then add 8 feet (2.4 m). Be sure there is sufficient extra tubing (about 8 feet [2.4 m] coiled into 3 turns of about 10 [25 cm] diameter) to allow the refrigerator to move out from the wall after installation.

Be sure that the kit you select allows at least 8 feet (2.4 m) as described above.

- **A cold water supply**. The water pressure must be between 20 and 120 p.s.i. on models without a water filter and between 40 and 120 p.s.i. on models with a water filter.

- **Power drill**.
- 1/2" or adjustable wrench.

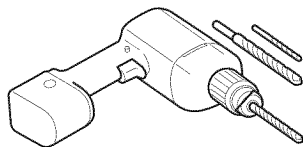

- **Flat head-and Phillips-screwdrivers**.

- **Two 1/4" outer diameter compression nuts and 2 Ferrules (sleeves)** to connect the copper tubing to the shutoff valve and the refrigerator water valve.

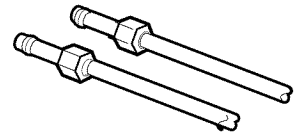

- If your existing copper water line has a flared fitting at the end, you will need an **adapter** (available at plumbing supply stores) to connect the water line to the refrigerator OR you can cut off the flared fitting with a tube cutter and then use a compression fitting.

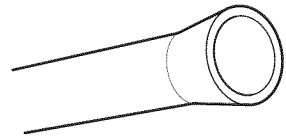

- **Shutoff valve to connect to the cold water line**. The shutoff valve should have a water inlet with a minimum inside diameter of 5/32" at the point of connection to the COLD WATER LINE. Saddle-type shutoff valves are included in many water supply kits. Before purchasing, make sure a saddle-type valve complies with your local plumbing codes.

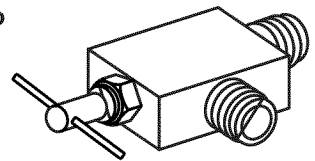

## INSTALLATION INSTRUCTIONS

Install the shutoff valve on the nearest frequently used drinking water line.

### 1. SHUTOFF THE MAIN WATER SUPPLY

Turn on the nearest faucet to relieve the pressure on the line.

### 2. CHOOSE THE VALVE LOCATION

Choose a location for the valve that is easily accessible. It is best to connect into the side of a vertical water pipe. When it is necessary to connect into a horizontal water pipe, make the connection to the top or side, either than at the bottom, to avoid drawing off any sediment from the water pipe.

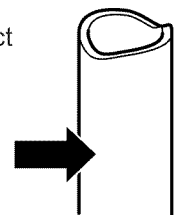

# CONNECTING THE WATER LINE

## 3. DRILL THE HOLE FOR THE VALVE

Drill a 1/4" hole in the water pipe (even if using a self-piercing valve) using a sharp bit. Remove any burrs resulting from drilling the hole in the pipe. Take care not to allow water to drain into the drill. Failure to drill a 1/4" hole may result in reduced ice production or smaller cubes.

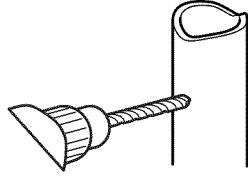

**NOTE:** The hookup line cannot be white, plastic tubing NDA tubing #49595 or 49499 or Cross Link Polyethylene (PEX) tubing.

## INSTALLATION INSTRUCTIONS (CONTINUED)

## 4. FASTEN THE SHUTOFF VALVE

Fasten the shutoff valve to the cold water pipe with the pipe clamp.

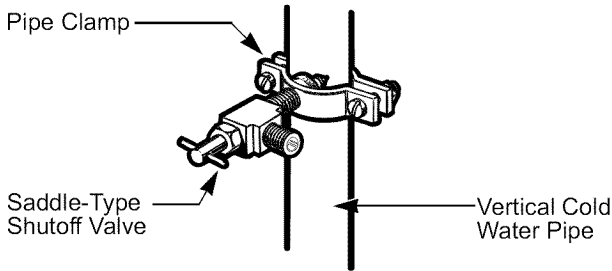

**NOTE:** Commonwealth of Massachusetts Plumbing Codes 248CMR shall be adhered to. Saddle valves are illegal and use is not permitted in Massachusetts. Consult with your licensed plumber.

## 5. TIGHTEN THE PIPE CLAMP

Tighten the clamp screws until the sealing washer begins to swell.

**NOTE:** Do not overtighten or you may crush the tubing.

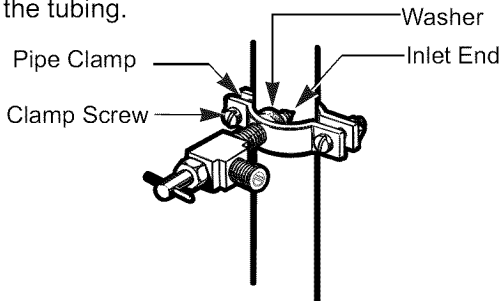

## 6. ROUTE THE TUBING

Route the tubing between the cold water line and the refrigerator.

Route the tubing through a hole drilled in the wall or floor (behind the refrigerator or adjacent base cabinet) as close to the wall as possible.

**NOTE:** Be sure there is sufficient extra tubing (about 8 feet coiled into 3 turns of about 10" diameter) to allow the refrigerator to move out from the wall after installation.

## 7. CONNECT THE TUBING TO THE VALVE

Place the compression nut and ferrule (sleeve) for copper tubing onto the end of the tubing and connect it to the shutoff valve. Make sure the tubing is fully inserted into the valve. Tighten the compression nut securely.

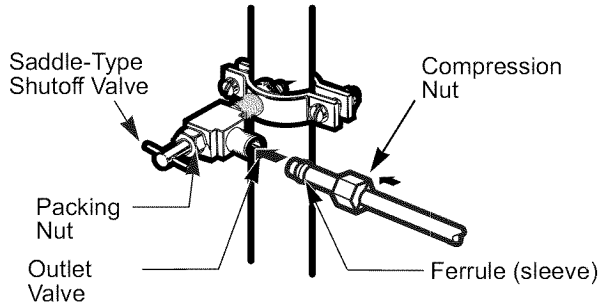

**NOTE:** Commonwealth of Massachusetts Plumbing Codes 248CMR shall be adhered to. Saddle valves are illegal and use is not permitted in Massachusetts. Consult with your licensed plumber.

## 8. FLUSH OUT THE TUBING

Turn the main water supply on and flush out the tubing until the water is clear.

Shut the water off at the water valve after about one quart of water has been flushed through the tubing.

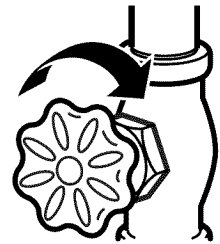

# CONNECTING THE WATER LINE

## 9. CONNECT THE TUBING TO THE REFRIGERATOR

### NOTES:

- Before making the connection to the refrigerator, be sure the refrigerator power cord is not plugged in to the wall outlet.
- If your refrigerator does not have a water filter, we recommend installing one. If your water supply has sand or particles that could clog the screen of the refrigerator's water valve. Install the filter in the water line near the refrigerator.

Remove the plastic flexible cap from the refrigerator connection.

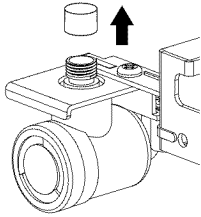

Place the compression nut and ferrule (sleeve) onto the end of the tubing.

Insert the end of the tubing into the connection as far as possible. While holding the tubing, tighten the fitting.

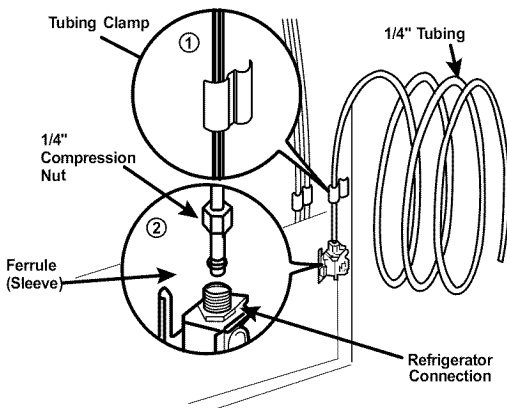

- ① Fasten the tubing into the tubing Clamp attached to the back of the refrigerator.
- ② First, loosen the screw fastening the clamp. Next, insert the tubing in the groove. Finally, re-fasten the screw.

## 10. TURN THE WATER ON AT THE SHUTOFF VALVE

Tighten any connections that leak.

Reattach the compressor compartment access cover.

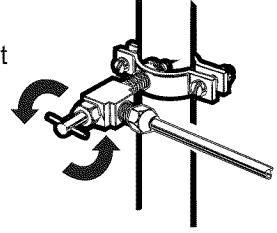

## 11. PLUG IN THE REFRIGERATOR

Arrange the coil of tubing so that it does not vibrate against the back of the refrigerator or against the wall. Push the refrigerator back to the wall.

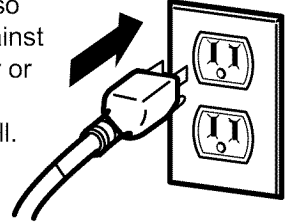

## 12. START THE ICE MAKER

Set the icemaker power switch to the ON position. The icemaker will not begin to operate until it reaches its operating temperature of 15°F (-9°C) or below. It will then begin operation automatically if the icemaker power switch is in the **I (on)** position.

# TROUBLESHOOTING GUIDE

## UNDERSTANDING SOUNDS YOU MAY HEAR

Your new refrigerator may make sounds that your old one didn't make. Because the sounds are new to you, you might be concerned about them. Most of the new sounds are normal. Hard surfaces, like the floor, walls and cabinets, can make the sounds seem louder than they actually are. The following describes the kinds of sounds and what may be making them.

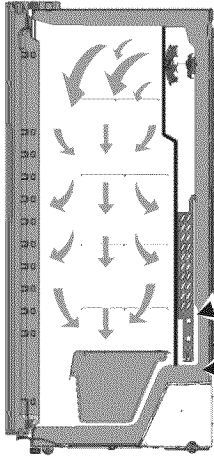

- The defrost timer will click when the automatic defrost cycle begins and ends. The thermostat control (or refrigerator control, depending on the model) will also click when cycling on and off.
- Rattling noises may come from the flow of refrigerant, the water line, or items stored on top of the refrigerator.
- Your refrigerator is designed to run more efficiently to keep your food items at the desired temperature. The high efficiency compressor may cause your new refrigerator to run longer than your old one, and you may hear a pulsating or high-pitched sound.
- You may hear the evaporator fan motor circulating the air through the refrigerator and freezer compartments.
- As each cycle ends, you may hear a gurgling sound due to the refrigerant flowing in your refrigerator.
- Contraction and expansion of the inside walls may cause a popping noise.
- Water dripping on the defrost heater during a defrost cycle may cause a sizzling sound.
- You may hear air being forced over the condenser by the condenser fan.
- You may hear water running into the drain pan during the defrost cycle.

## REFRIGERATOR DOES NOT OPERATE

Check if...

Then...

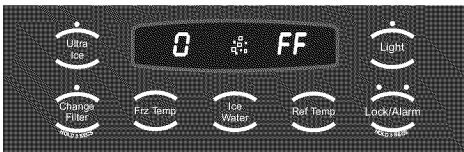
The power supply cord is unplugged.	Firmly plug the cord into a live outlet with proper voltage.
A household fuse has blown or circuit breaker tripped.	Replace the fuse or reset the circuit breaker.
Refrigerator is in the defrost cycle.	Wait about 30 minutes for defrost cycle to end.
Display shows the word OFF 	The refrigerator control has been put into the store Demo (Demonstration) Mode. The Demonstration Mode disables the cooling system, only lamps and display work normally. To disable Demo Mode open one door, then press Ultra Ice and Ref. Temp buttons at the same time for 5 seconds. You will see the previous value setting you had on display when Demo Mode is deactivated.

## VIBRATION OR RATTLING NOISE

Check if...

Then...

The refrigerator is not resting solidly on the floor.	Floor is weak or uneven or leveling legs need adjusting. See <b>LEVELING AND DOOR CLOSING</b> Section.
---	--

## LIGHTS DO NOT WORK

Check if...

Then...

The power supply cord is unplugged.	Firmly plug the cord into a live outlet with proper voltage.
Light bulb is loose in the socket.	Turn the refrigerator control to the OFF position and Unplug the refrigerator. Gently remove the bulb and reinsert. Then plug in refrigerator and reset the refrigerator control.

## TROUBLESHOOTING GUIDE

### LIGHTS DO NOT WORK

Check if...

Then...

Light bulb has burned out.	Replace with an appliance bulb of the same wattage, size and shape available at your local hardware store. (See the <b>LIGHT BULB REPLACEMENT</b> Section.) Turn the temperature control to the OFF position and unplug the refrigerator prior to replacement.
----------------------------	--

### COMPRESSOR MOTOR SEEMS TO RUN TOO MUCH

Check if...

Then...

The refrigerator that was replaced was an older model.	Modern refrigerators with more storage space require more operating time.
The room temperature is hotter than normal.	The motor will run longer under warm conditions. At normal room temperatures, expect your motor to run about 40% to 80% of the time. Under warmer conditions, expect it to run even more often.
The door is opened often or a large amount of food has just been added.	Adding food and opening the door warms the refrigerator. It is normal for the refrigerator to run longer in order to cool the refrigerator back down. Adding a large amount of food warms the refrigerator. See the <b>FOOD STORAGE GUIDE</b> Section. In order to conserve Energy, try to get everything you need out of the refrigerator at once, keep food organized so it is easy to find and close the door as soon as the food is removed.
The refrigerator was recently plugged in and the refrigerator control was set correctly	The refrigerator will take up to 24 hours to cool completely.
The refrigerator control was not set correctly for the surrounding conditions.	See the <b>ADJUSTING CONTROL SETTINGS</b> Section.
The doors are not closed completely.	Push the doors firmly shut. If they will not shut all the way, see Doors will not close completely below.
The condenser coils are dirty.	This prevents air transfer and makes the motor work harder. Clean the condenser coils. Refer to the <b>CARE AND CLEANING</b> section.

### DOORS WILL NOT CLOSE COMPLETELY

Check if...

Then...

The refrigerator is not level.	See the <b>REFRIGERATOR INSTALLATION, LEVELING AND DOOR ALIGNMENT</b> Section to level refrigerator.
Food packages are blocking the door open.	Rearrange food containers to clear door and door shelves.
The ice bin, crisper cover, pans, shelves, door bins or baskets are out of position.	Push bins all the way in and put crisper cover, pans, shelves and baskets into their correct positions. See the <b>USING YOUR REFRIGERATOR</b> Section.
The gaskets are sticking.	Clean gaskets and the surface that they touch. Rub a thin coat of paraffin wax on the gaskets after cleaning.

## TROUBLESHOOTING GUIDE

### DOORS WILL NOT CLOSE COMPLETELY

Check if...	Then...
The refrigerator wobbles or seems unstable.	Level the refrigerator. Refer to the <b>LEVELING AND DOOR CLOSING</b> section.
The doors were removed during product installation and not properly replaced.	Remove and replace the doors according to the <b>REMOVING, AND REPLACING or REVERSING DOORS</b> section, or call Sears or other qualified service technician.

### FROST OR ICE CRYSTALS ON FROZEN FOOD

Check if...	Then...
The door is not closing properly.	See "Doors will not close completely" above.
The door is opened often.	When the door is opened, warm, humid air is allowed in the freezer resulting in frost.

### ICE HAS OFF-TASTE OR ODOR

Check if...	Then...
The icemaker was recently installed.	Discard first few batches of ice to avoid discolored or off-flavored ice.
The ice has been stored for too long.	Throw away old ice and make new supply.
The food has not been wrapped tightly in either compartment.	Rewrap foods since odors may migrate to the ice if food is not wrapped properly.
The water supply contains minerals such as sulfur.	A filter may need to be installed to eliminate taste and odor problems.
The interior of refrigerator needs cleaning.	See <b>CARE AND CLEANING</b> section.
Ice storage bin needs cleaning.	Empty and wash bin. Discard old cubes.

### THERE IS WATER IN THE DEFROST DRAIN PAN

Check if...	Then...
The refrigerator is defrosting.	The water will evaporate. It is normal for water to drip into the defrost pan.
It is more humid than normal.	Expect that the water in the defrost pan will take longer to evaporate. This is normal when it is hot or humid.

### THE REFRIGERATOR SEEMS TO MAKE TOO MUCH NOISE

Check if...	Then...
The sounds may be normal for your refrigerator.	Refer to the <b>UNDERSTANDING SOUNDS YOU MAY HEAR</b> section.

## TROUBLESHOOTING GUIDE

### THE ICEMAKER IS NOT PRODUCING ICE OR ICE CUBES ARE FREEZING TOO SLOWLY

Check if...	Then...
The freezer temperature is cold enough to produce ice.	Wait 24 hours after hook-up for ice production. See the <b>SETTING THE CONTROLS</b> section.
Door left open.	Check to see if something is holding the door open.

### CUBES PRODUCED BY ICEMAKER ARE TOO SMALL

Check if...	Then...
Smaller cube size level is selected.	Select larger cube size using cube size selector.
Water shutoff valve connecting refrigerator to water line may be clogged.	Call a plumber to clear the valve.

### THE DOORS ARE DIFFICULT TO OPEN

Check if...	Then...
The gaskets are dirty or sticky.	Clean gaskets and the surfaces that they touch. Rub a thin coat of appliance polish or kitchen wax on the gaskets after cleaning
The door is reopened within a short time after having been opened.	When you open the door, warmer air enters the refrigerator. As the warm air cools, it can create a vacuum. If the door is hard to open, wait 5 minutes to allow the air pressure to equalize, then see if it opens more easily.

### AUTOMATIC ICEMAKER DOES NOT WORK

Check if...	Then...
Icemaker power switch in the <b>O (off)</b> position.	Move the switch to the <b>I (on)</b> position.
Water supply turned off or not connected.	See the <b>CONNECTING THE WATER LINE</b> section.
Freezer compartment too warm.	Wait 24 hours for the freezer to reach its ideal temperature.
Piled up cubes in the storage bin cause the icemaker to shut off.	Level cubes by hand or shake the bin occasionally.

### TEMPERATURE IS TOO WARM OR THERE IS INTERIOR MOISTURE BUILDUP

Check if...	Then...
The air vents are blocked. Cold air circulates from the freezer to the fresh food section and back again through air vents in the wall dividing the two sections.	Locate air vents by using your hand to sense airflow and move all packages that block vents and restrict airflow. Refer to <b>ENSURING PROPER AIR CIRCULATION</b> section for the location of air vents.

## TROUBLESHOOTING GUIDE

### TEMPERATURE IS TOO WARM OR THERE IS INTERIOR MOISTURE BUILDUP

Check if...

Then...

The doors are opened often.	When the door is opened, warm humid air is allowed into the refrigerator. The more the door is opened, the faster the humidity builds up, and the more warm air the refrigerator must cool. In order to keep the refrigerator cool, try to get everything you need out of the refrigerator at once, keep food organized so it is easy to find and close the door as soon as the food is removed.
The control is not set correctly for the surrounding conditions.	Refer to the <b>SETTING THE CONTROLS</b> section. Wait 24 hours for temperatures to stabilize or even out. If the temperature is too cold or too warm, move the dial one number at a time.
A large amount of food has just been added to the refrigerator or freezer.	Adding food warms the refrigerator. It can take a few hours for the refrigerator to return to normal temperature.
The food is not packaged correctly.	Wrap food tightly and wipe off damp containers prior to storing in the refrigerator to avoid moisture accumulation. If necessary, repackage food according to the guidelines in the <b>FOOD STORAGE GUIDE</b> section.
The doors are not closing completely.	See <b>“Doors will not close completely”</b> .
The weather is humid.	In humid weather, air carries moisture into refrigerator when doors are opened.
A self-defrost cycle was completed.	It is normal for droplets to form on the back wall after the refrigerator self-defrosts.

### WATER DISPENSER DOES NOT WORK

Check if...

Then...

Water does not dispense.	Check if house valve is opened and connected to a recommended water supply. See water line installation.
Water does not dispense correctly.	Purge system of air by dispensing approximately 1 gallon of water.

# Get it fixed, at your home or ours!

## Your Home

For expert troubleshooting and home solutions advice:

**manage my home**

[www.managemyhome.com](http://www.managemyhome.com)

For repair – **in your home** – of **all** major brand appliances, lawn and garden equipment, or heating and cooling systems, **no matter who made it, no matter who sold it!**

For the replacement parts, accessories and owner's manuals that you need to do-it-yourself.

For Sears professional installation of home appliances and items like garage door openers and water heaters.

**1-800-4-MY-HOME®**

(1-800-469-4663)

[www.sears.com](http://www.sears.com)

Call anytime, day or night

(U.S.A. and Canada)

[www.sears.ca](http://www.sears.ca)

## Our Home

For repair of carry-in items like vacuums, lawn equipment, and electronics, call anytime for the location of the nearest **Sears Parts & Repair Service Center**

**1-800-488-1222** (U.S.A.)

[www.sears.com](http://www.sears.com)

**1-800-469-4663** (Canada)

[www.sears.ca](http://www.sears.ca)

To purchase a protection agreement on a product serviced by Sears:

**1-800-827-6655** (U.S.A.)

**1-800-361-6665** (Canada)

Para pedir servicio de reparación a domicilio, y para ordenar piezas:

**1-888-SU-HOGAR®**

(1-888-784-6427)

Au Canada pour service en français:

**1-800-LE-FOYER<sup>MC</sup>**

(1-800-533-6937)

[www.sears.ca](http://www.sears.ca)



© Sears Brands, LLC

® Registered Trademark / <sup>TM</sup> Trademark / <sup>SM</sup> Service Mark of Sears Brands, LLC

® Marca Registrada / <sup>TM</sup> Marca de Fábrica / <sup>SM</sup> Marca de Servicio de Sears Brands, LLC

<sup>MC</sup> Marque de commerce / <sup>MD</sup> Marque déposée de Sears Brands, LLC