

# ENDEAVOR GRILL

## Use and Care Guide Installation Guide



### Models:

- EDV27-BQ
- EDV27-BQR
- EDV36-BQA
- EDV36-BQAR



## A Message To Our Customers

Thank you for selecting this Professional “ENDEAVOR” Series Grills. Because of these appliances’ unique features we have developed this Use and Care Guide and Installation Guide. It contains valuable information on how to properly operate and maintain your new appliance for years of safe and enjoyable cooking.

To help serve you better, please fill out and return the Ownership Registration Card and keep this guide handy, as it will help answer questions that may arise as you use your new appliance.

For your convenience, product questions can be answered by a Consumer Service Representative at 877-553-0243.

### **WARNING**

*Improper installation, adjustment alteration, service or maintenance can cause property damage, injury or death. Read the installation, operating and maintenance instructions thoroughly before use, installing or servicing this equipment. For outdoor use only.*

### **PRECAUTION**

*Do Not store or use gasoline or any other flammable vapors and liquids in the vicinity of this or any other appliance.*

### **FOR YOUR SAFETY**

*If you smell gas:*

- 1. Shut-off gas to the appliance.*
- 2. Extinguish any open flames.*
- 3. If odor continues, immediately call your gas supplier.*

### **WARNING**

*A separate regulator must be installed at the appliance. A regulator is supplied with this product.*

**PLEASE RETAIN THIS MANUAL  
FOR FUTURE REFERENCE.**

# Table Of Contents

<b>SAFETY PRACTICES &amp; PRECAUTIONS</b> .....	3-4
<b>GRILL MODELS</b> .....	5
<b>GAS REQUIREMENTS</b> .....	6-7
<b>LOCATING GRILL/BUILT-IN CLEARANCES</b> .....	8-9
<b>BUILT-IN CONSTRUCTION DETAILS</b> .....	10-11
<b>LEAK TESTING</b> .....	12
<b>INSTALLER FINAL CHECKLIST</b> .....	13
<b>BURNER ADJUSTMENTS</b> .....	13-14
<b>USING THE GRILL</b> .....	15-16
<b>LIGHTING INSTRUCTIONS</b> .....	16-17
<b>USING THE ROTISSERIE</b> .....	18-19
<b>CARE &amp; CLEANING</b> .....	20
<b>BURNER REMOVAL AND CLEANING</b> .....	21
<b>TROUBLESHOOTING</b> .....	22
<b>PARTS LISTS</b>	
Grill Burner Assembly 27” Parts List.....	23
Grill Body 27” Parts List.....	24
Rotisserie Assembly 27” Parts List.....	25
Grill Burner Assembly 36” Parts List.....	26
Grill Body 36” Parts List.....	27
Rotisserie Assembly 36” Parts List.....	28
Cart Assembly 27” and 36” Parts List .....	29
<b>HEAD AND CART ASSEMBLY</b> .....	30
<b>WIRING DIAGRAM</b>	
Wiring Diagram for EDV27-BQ.....	31
Wiring Diagram for EDV27-BQR .....	32
Wiring Diagram for EDV36-BQA .....	33
Wiring Diagram for EDV36-BQAR.....	34
<b>SERVICE</b> .....	35
<b>WARRANTY</b> .....	36

## Safety Practices & Precautions

**IMPORTANT SAFETY NOTICE:**  
**Certain Liquid Propane dealers may fill liquid propane cylinders for use in the grill beyond cylinder filling capacity. This “Overfilling” may create a dangerous condition.**

- “Overfilled” tanks can build up excess pressure. As a safety device, the tanks pressure relief valve will vent propane gas vapor to relieve this excess pressure. This vapor is combustible and therefore can be ignited. To reduce this danger, you should take the following safety precautions:

1. When you have your tank filled, be sure you tell the supplier to fill it to no more than 3/4 (75%) of its total capacity.
2. If you own or use an extra spare tank, or have a disconnected tank, you should NEVER store it near or under the grill unit or heat box, or near any other ignition or heat source. A metallic sticker with this warning is attached to the grill to remind you, your family and all others who may use your BBQ grill of these safety precautions.



**Do not remove this sticker.**

**WARNING: Do not try lighting this appliance without reading the “LIGHTING INSTRUCTIONS” section of this manual.**

- **This Grill is for outdoor use only.**
- Children should not be left alone or unattended in an area where the grill is being used. Never allow them to sit, stand or play on or around the grill at any time. When in use, portions of the grill get hot enough to cause severe burns.
- Do not store items of interest to children around or below the grill, in the cart or masonry enclosure. Never allow children to crawl inside a cart or enclosure.
- Never let clothing, pot holders or other flammable materials come in contact with or too close to any grate, burner or hot surface until it has cooled. Fabric may ignite and result in personal injury.
- Do not heat unopened food containers as a build-up of pressure may cause the container to burst.
- Use a covered hand when opening the grill lid and only do so slowly to allow heat and steam to escape.
- Never lean over an open grill. When lighting a burner, always pay close attention to what you are doing. Be certain you are turning the knob labeled for the burner you intend on using.
- When using the grill, do not touch the grill rack, burner grate or immediate surrounding area as these areas become extremely hot and could cause burns.
- Grease is flammable. Let hot grease cool before attempting to handle it. Avoid letting grease deposits collect in the drip pan. Clean often.
- Do not use aluminum foil to line drip pans or grill racks. This can severely upset combustion air flow or trap excessive heat in the control area. The result of this can be melted knobs or ignition module.
- Begin by insuring proper installation and servicing. Follow the installation instructions. Have your grill installed by a qualified technician. Have the installer show you where the gas supply shut-off valve is located so that you know where to shut-off the gas to the grill. If you smell gas, your installer has not done a proper job of checking for leaks. If the connections are not perfectly seated and tightened, you can have a small leak and therefore a faint gas smell. Finding a leak is not a “do-it-yourself” procedure. Some leaks can only be found with the burner control in the “on” position and this must be done by a qualified technician.

## Safety Practices & Precautions

For personal safety, wear proper apparel. Loose fitting garments or sleeves should never be worn while using this appliance. Some synthetic fabrics are highly flammable and should not be worn while cooking. Only certain types of glass, heat-proof glass ceramic, earthenware, or other glazed utensils are suitable for grill use. Use of these types of materials may break with sudden temperature changes. Use only on low or medium heat settings according to the manufacturer's directions.

**WARNING: Spiders and insects can nest in the burners of this and any other grill, and cause the gas to flow from the front of the burner. This is a very dangerous condition which can cause a fire to occur behind the valve panel, thereby damaging the grill and making it unsafe to operate.**

- Clean the grill with caution. Avoid steam burns; do not use a wet sponge or cloth to clean the grill while it is hot. Some cleaners produce noxious fumes or can ignite if applied to a hot surface.
- Be sure all grill controls are turned off and the grill is cool before using any type of aerosol cleaner on or around the grill. The chemical that produces the spraying action could, in the presence of heat, ignite or cause metal parts to corrode.
- Do not use the grill for cooking excessively fatty meats or products which promote flare-ups.
- Never grill without the drip pan in place and pushed all the way to the back of the grill. Without it hot grease could leak downward and produce a fire or explosion hazard.
- Do not operate the grill under unprotected combustible construction. Use only in well ventilated areas. Do not use in buildings, garages, sheds, breezeway or other such enclosed areas. This unit is for outdoor use only.
- Keep the area surrounding the grill free from combustible materials, trash, or combustible fluids and vapors such as gasoline or charcoal lighter fluid. Do not obstruct the flow of combustion and ventilation air.
- If a cart unit is stored indoors ensure that it is cool, then push, never pull, the grill. If LP, the cylinder must be unhooked and the LP cylinder stored outside in a well ventilated area, out of reach of children.
- Do not use charcoal in the grill. Never use the grill in a windy area. Keep any electrical supply cord, or the rotisserie motor cord away from the heated areas of the grill.
- Never use the grill in windy conditions. If located in a consistently windy area (oceanfront, mountaintop, etc.) a wind break will be required. Always adhere to the specified clearances listed.
- Never use a dented or rusty LP tank. Keep the ventilation openings of the cylinder enclosure free and clear from debris.
- Use only dry potholders; moist or damp potholders on hot surfaces may cause burns from steam. Do not use a towel or bulky cloth in place of potholders. Do not let potholders touch hot portions of the grill rack or burner grate.
- CALIFORNIA PROPOSITION 65-WARNING: The Burning of gas cooking fuel generates some by products which are on the list of substances which are known by the State of California to cause cancer or reproductive harm. California law requires businesses to warn customers of potential exposure to such substances. To minimize exposure to these substances always operate this unit according to the use and care manual, ensuring you provide good ventilation when cooking with gas.

## Grill Models

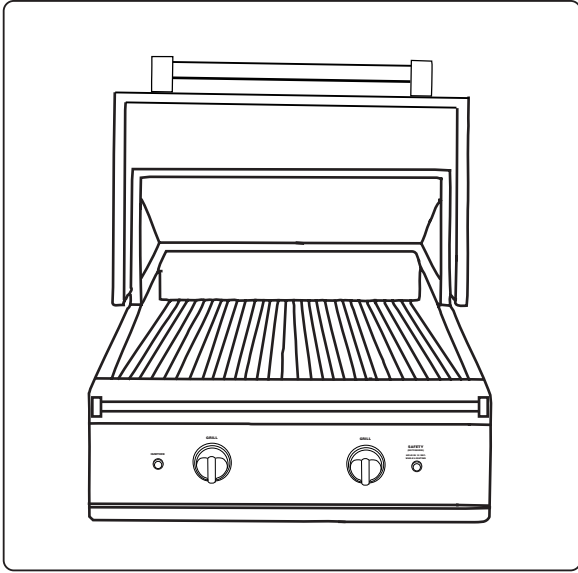

**EDV27-BQ**

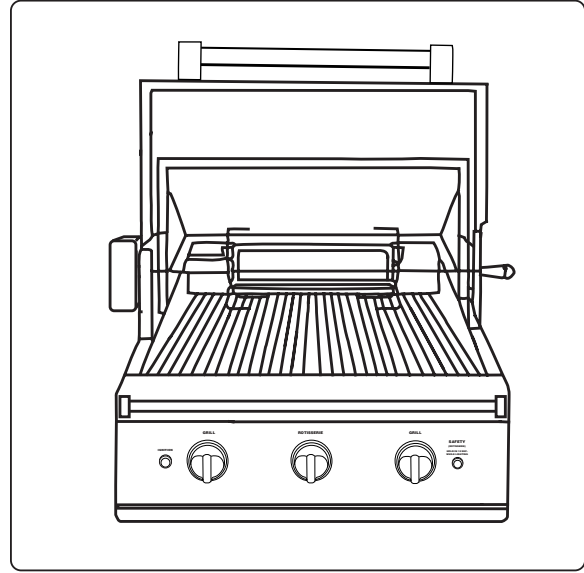

**EDV27-BQR**

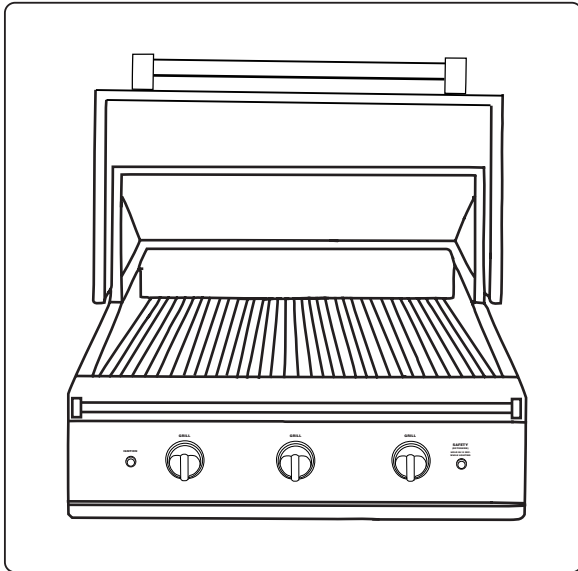

**EDV36-BQA**

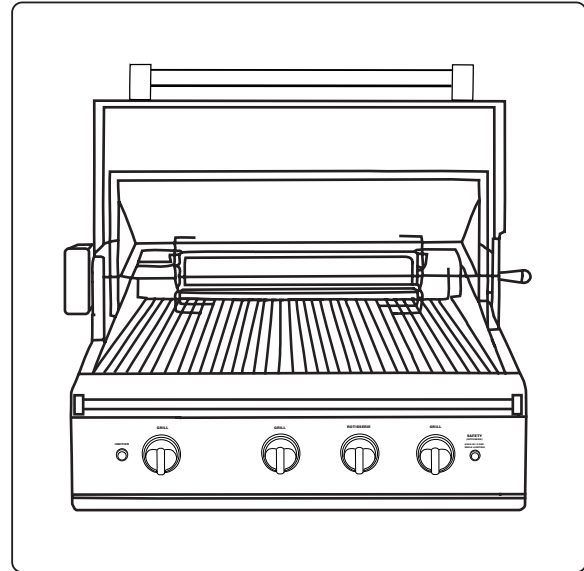

**EDV36-BQAR**

## Gas Requirements

Verify the type of gas supply to be used, either natural or LP, and make sure the marking on the appliance rating plate agrees with that of the supply. Never connect an unregulated gas line to the appliance.

An installer supplied gas shut-off valve must be installed in an easily accessible location. All installer supplied parts must conform to local codes, or in the absence of local codes, with the National Electrical Code, ANSI/NFPA 70-1990, and the National Fuel Gas Code, ANSI Z223.1-1988.

All pipe sealants must be an approved type and resistant to the actions of LP gases. Never use pipe sealant on flare fittings. All gas connections should be made by a qualified technician and in accordance with local codes and ordinances. In the absence of local codes, the installation must comply with the national fuel gas code ANSI Z223.1-1988. Gas conversion kits are available from the factory. When ordering gas conversion kits have the model number, and the type of gas (natural or LP) from your grill.

### TOTAL GAS CONSUMPTION OF THE GRILL WITH ALL BURNERS ON HI:

EDV27-BQR - 54,000 Btu/hr  
EDV27-BQ - 40,000 Btu/hr  
EDV36-BQA - 60,000 Btu/hr  
EDV36-BQAR - 74,000 Btu/hr

The appliance and its individual shut-off valve must be disconnected from the gas supply piping system during any pressure testing of that system at test pressures in excess of 1/2 PSIG (3.5 kPa.) The appliance must be isolated from the gas supply piping system by closing its individual manual shut-off valve during any pressure testing of the gas supply piping system at test pressures equal to or less than 1/2 PSIG (3.5 kPa.). The installation of this appliance must conform with local codes or, in the absence of local codes, with the national fuel gas code, ANSI Z223.1a-1988. Installation in Canada must be in accordance with the Standard Can1-b149.1 and/or .2 (installation code for gas burning appliances and equipment) and local codes.

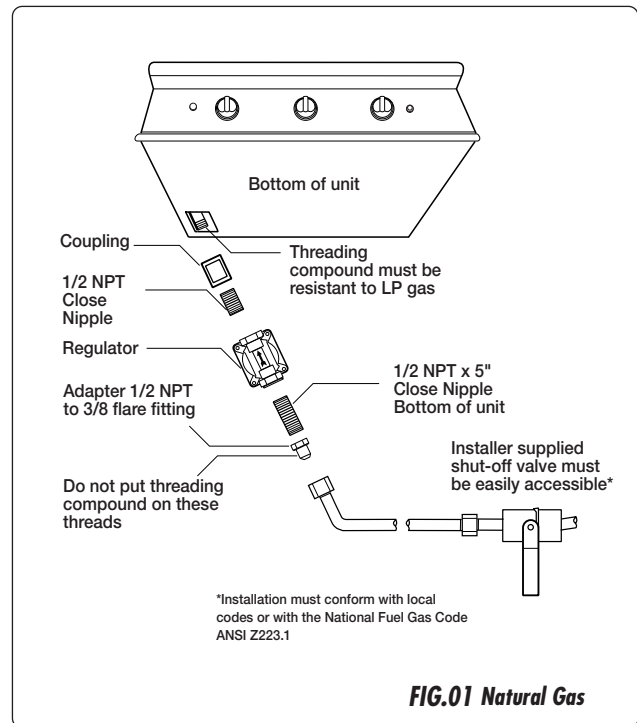

### NATURAL GAS HOOK UP:

**Connection:** 1/2" NPT male with 3/8" flare adapter. **Operating pressure:** 4.0" W.C.

**Supply pressure:** 5" to 14" water column. If in excess of 14" W.C. a step down regulator is required. Check with your local gas utility company or with local codes for instructions on installing gas supply lines. Be sure to check on type and size of run, and how deep to bury the line. If the gas line is too small, the grill will not function properly. Any joint sealant used must be an approved type and be resistive to the actions of LP gases.

### TO HOOK-UP THE FITTINGS SUPPLIED WITH THE GRILL:

Assemble as shown (Fig.01). Use threading compound on male threads only. Do not use threading compound on the male end of the 1/2 NPT to 3/8 flare adapter. Use a second pipe wrench to hold the grill inlet pipe to avoid shifting any internal gas lines of the grill. Ensure that the regulator arrow points in the direction of gas flow towards the unit, away from the supply. Do not forget to place the installer supplied gas valve in an accessible location.



# Gas Requirements

## LP GAS HOOK UP (TYPE 1 OR QCC1 REGULATOR):

Grills orificed for use with LP gas come equipped with a high capacity hose/regulator assembly for connection to a standard 20 lb. LP cylinder (Type 1). The LP tank is not included.

**Connection:** 1/2" NPT male with a 3/8" Flare adapter (included). LP Hose with a quick disconnect and fittings are included.

**Operating pressure:** 10.0" W.C.

To connect the LP regulator/hose assembly to the tank/valve assembly, first make sure the main valve on the tank is completely closed. Although the flow of gas is stopped when the Type 1 system is disconnected as part of its safety feature, you should always turn the LP tank main valve (Fig.02) off after each use and during transport of the tank or unit. Insert the regulator inlet into the tank valve and turn to the black coupler clockwise until the coupler tightens up. **Do not overtighten the coupler.** Turn the main tank valve on and turn the burner control valves on the unit to the "HI" position for about 20 seconds to allow the air in the system to purge before attempting to light the burners.

To disconnect the coupler, first make sure the main tank valve is turned off. Grasp the coupler and turn counter clockwise. The inlet will then disengage, remove the inlet from the tank valve opening if it has not already done so when it

disengaged. Your local LP filling station should be equipped with the proper equipment to fill your tank.

## LP TANK REQUIREMENTS:

A dented or rusty LP tank may be hazardous and should be checked by your LP supplier. Never use a cylinder with a damaged valve. Always check for leaks after every LP tank change. The LP gas cylinder must be constructed and marked in accordance with the specifications for LP gas cylinders of the U.S. Department of Transportation (DOT) and designed for use with a Type 1 system only. Do not change the regulator/hose assembly from that supplied with the unit or attempt to use a Type 1 equipped regulator/hose assembly with a standard 510 POL tank/valve assembly. The cylinder must be provided with a shut-off valve terminating in an LP gas supply cylinder valve outlet specified, as applicable, for connection Type 1. If the appliance is stored indoors the cylinder must be disconnected and removed from the appliance. Cylinders must be stored outdoors in a well-ventilated area out of the reach of children.

**Note:** When a LP unit is directly attached into a LP house system, the step down regulator **MUST** be used to reduce the supply pressure to a max. 14" W.C. and min. 11" W.C. to the grill regulator.

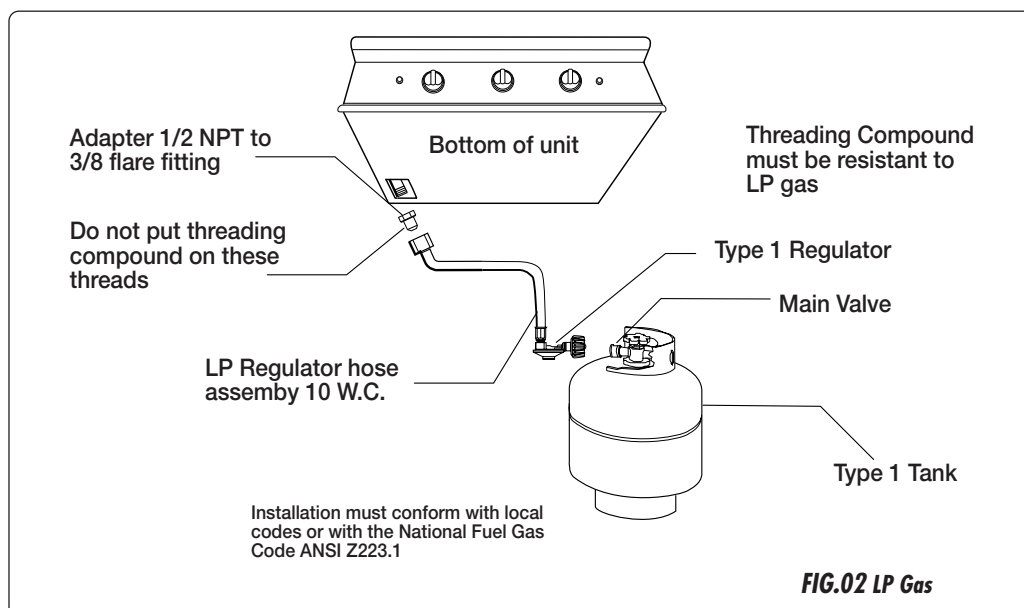



## Locating Grill / Built-In Clearances

### **INSULATED JACKET:**

Do not build the Grill under overhead unprotected combustible construction. If the Grill is to be placed into a combustible enclosure, an approved insulated jacket is necessary and is available from your dealer. Use only the insulated jacket which has specifically been designed and tested for this purpose.

### **LOCATION:**

When determining a suitable location take into account concerns such as exposure to wind, proximity to traffic paths and keeping any gas or electrical supply lines as short as possible. Locate the grill only in a well ventilated area. Never locate the grill in a building, garage, breezeway, shed or other such enclosed areas without an approved ventilation system. During heavy use, the grill will produce a lot of smoke. Ensure there is adequate area for it to dissipate.

**IMPORTANT:** Gas fittings, regulator, and installer supplied shut-off valves must be easily accessible.

### **CLEARANCES TO COMBUSTIBLE CONSTRUCTION:**

A Minimum of 12" from the sides and a minimum of 12" from the back must be maintained from the Grill above and below the cooking surface to adjacent vertical combustible construction.

### **CLEARANCES TO NON-COMBUSTIBLE CONSTRUCTION:**

A minimum of 3" clearance from the back of the grill to non-combustible construction is required for the purpose of allowing the lid to open fully. It is desirable to allow at least 6" side clearance to non-combustible construction above the cooking surface for counter space. If you'll be using the rotisserie option, the space is essential for motor and skewer clearance. The Grill can be placed directly adjacent to non-combustible construction below the cooking surface.

# Built-In Grill Clearances

## FOR MODEL 27"

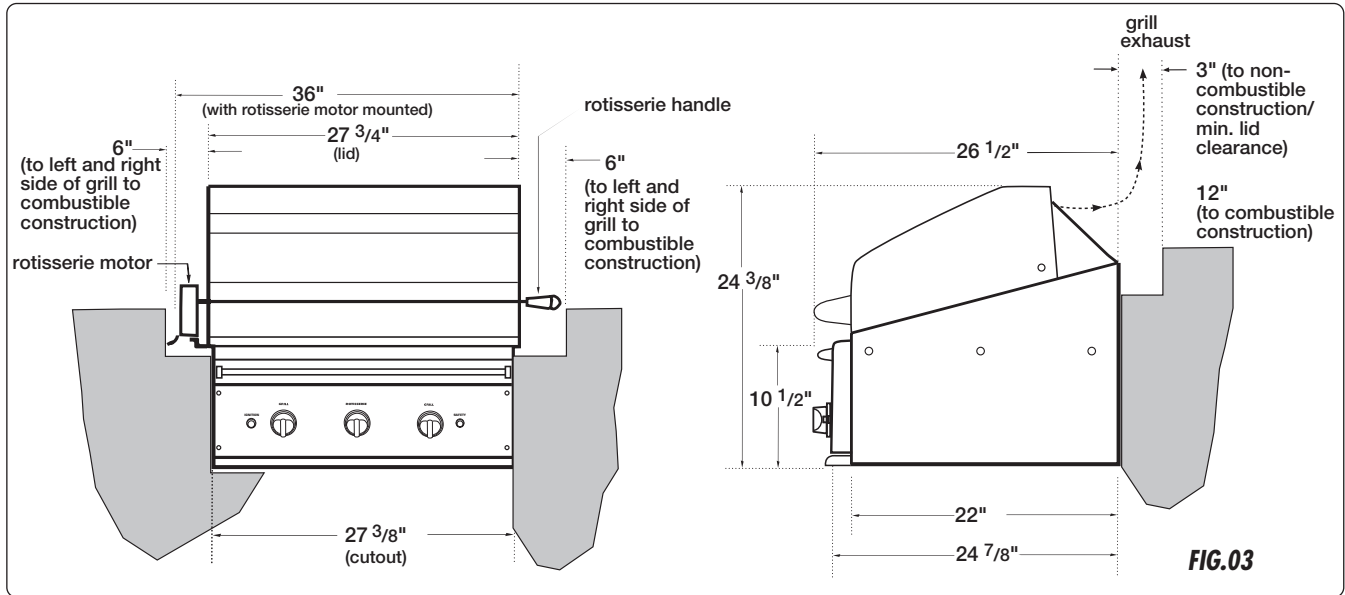

## FOR MODEL 36"

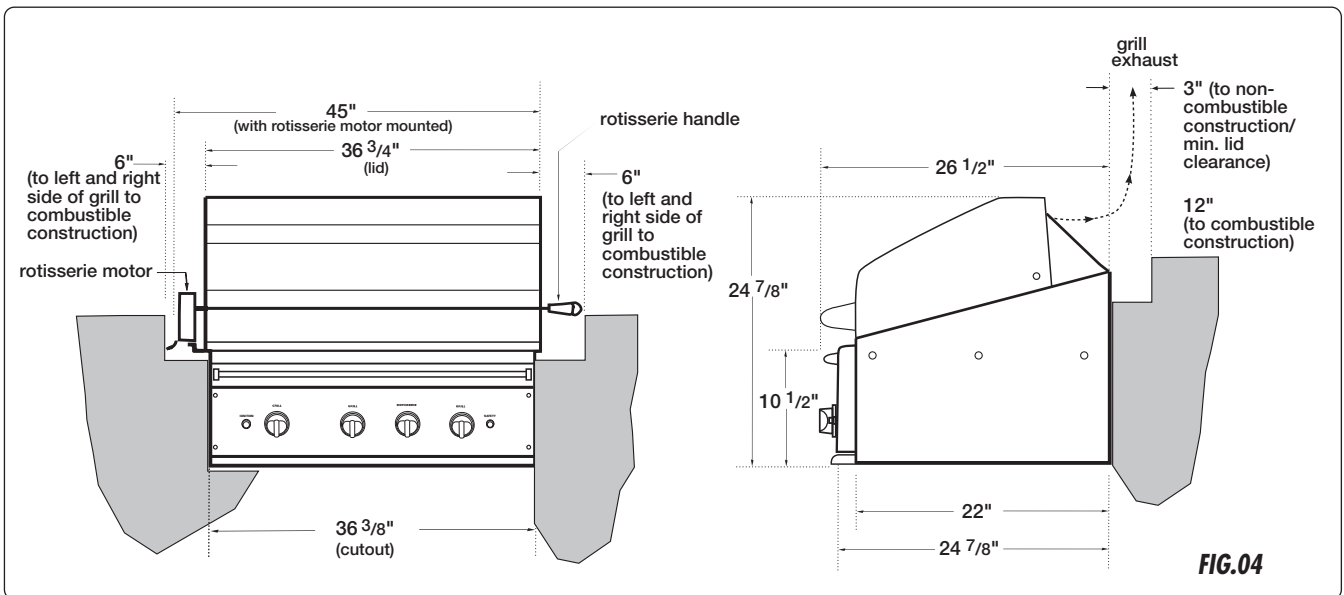

### GENERAL:

The Grill is designed for easy placement into masonry enclosures. For non-combustible applications the grill drops into the opening shown in (Fig. 05 & Fig. 06). A deck or ledge is required to support it from the bottom. When using the insulated jacket in a combustible enclosure application, (Fig. 05 & Fig. 06) bottom, the jacket assembly must be supported from the bottom by a ledge on each side or a solid deck beneath the entire grill or insulated jacket.

Review the detail drawings shown and take into account the provisions shown for gas line hook-up clearance in the left rear corner. It is recommended that ventilation holes are provided in the enclosure in the event of a gas leak. The supporting ledges or deck must be level and flat. The counter should also be level.

# Built-In Construction Details – 27”

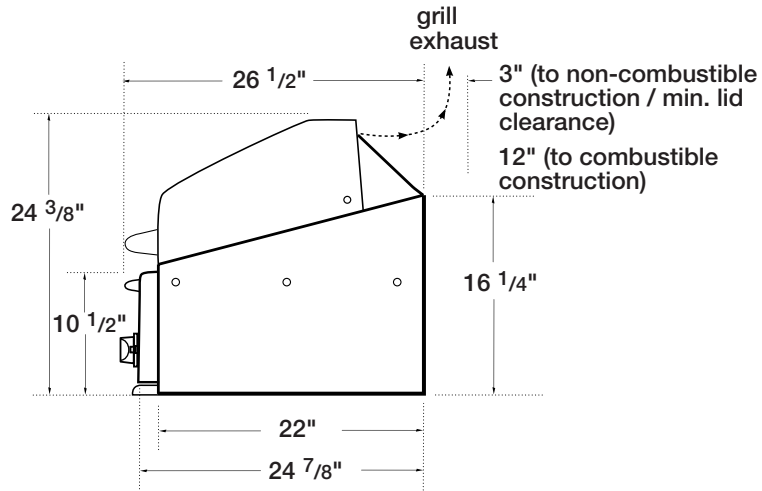

## STANDARD LAYOUT FOR NON-COMBUSTIBLE ENCLOSURE:

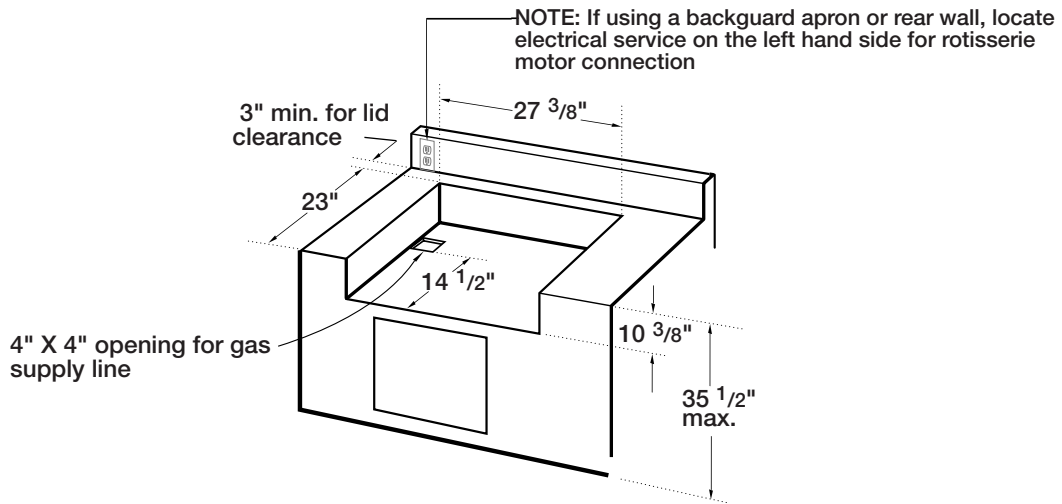

## INSULATED JACKET LAYOUT FOR COMBUSTIBLE ENCLOSURE:

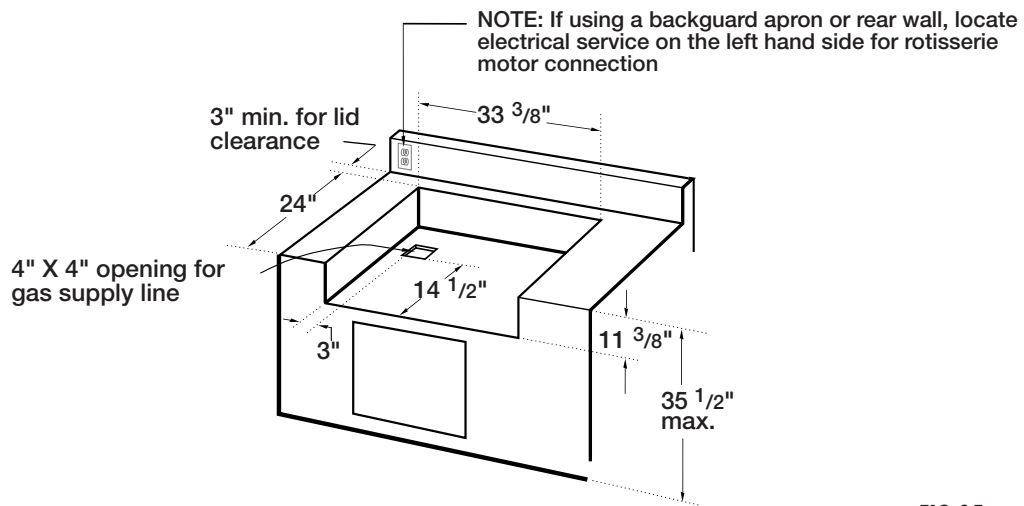
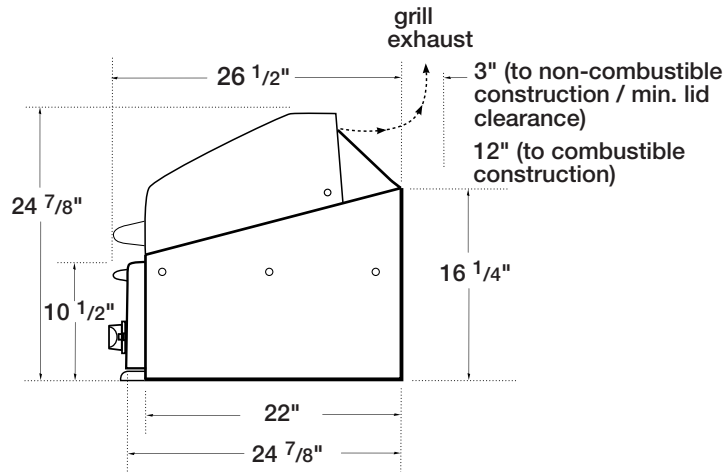
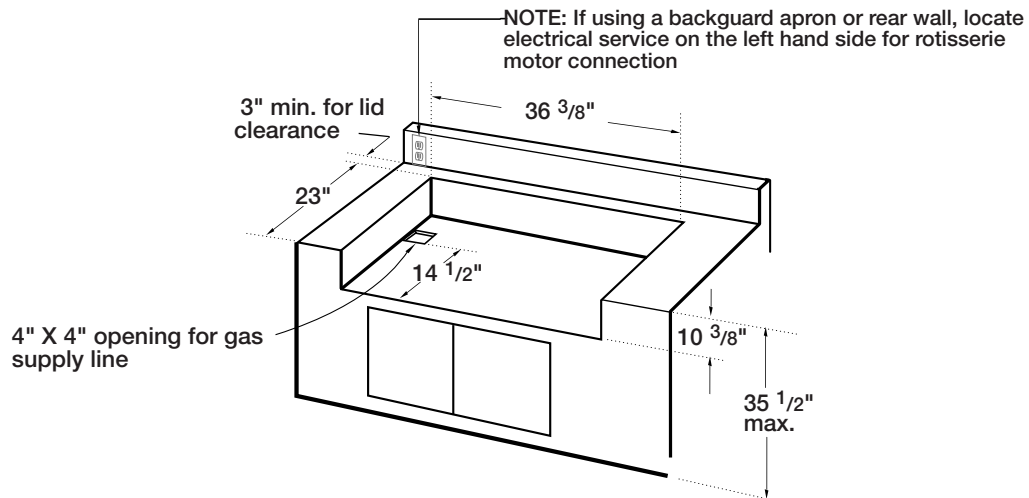

FIG.05

# Built-In Construction Details – 36"



## STANDARD LAYOUT FOR NON-COMBUSTIBLE ENCLOSURE:



## INSULATED JACKET LAYOUT FOR COMBUSTIBLE ENCLOSURE:

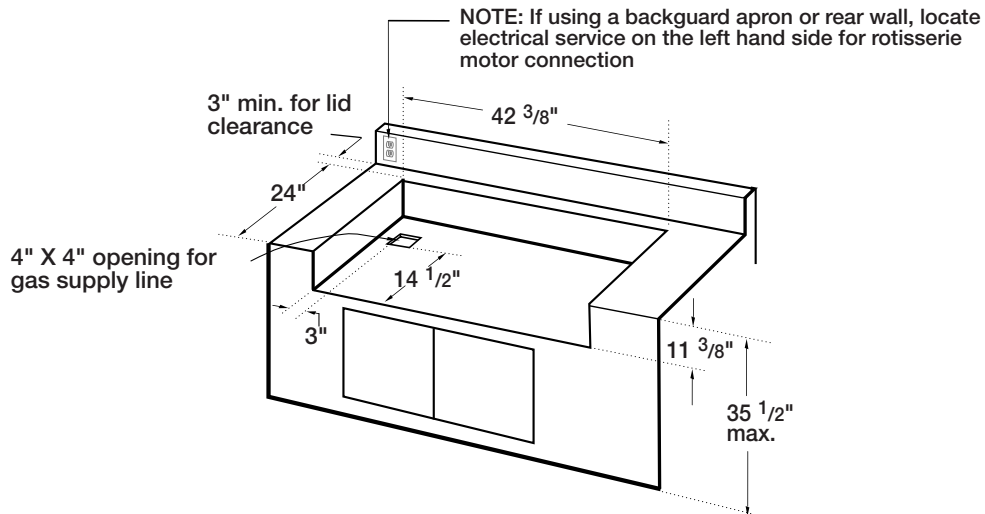

FIG.06

# Leak Testing

## GENERAL:

Although all gas connections on the grill are leak tested at the factory prior to shipment, a complete gas tightness check must be performed at the installation site due to possible mishandling in shipment, or excessive pressure unknowingly being applied to the unit. Periodically check the whole system for leaks, or immediately check if the smell of gas is detected.

## BEFORE TESTING:

**Do not smoke while leak testing. Extinguish all open flames. Never leak test with an open flame.** Make a soap solution of one part liquid detergent and one part water. You will need a spray bottle, brush, or rag to apply the solution to the fittings. For LP units, check with a full cylinder. The valve panel must be removed to check the valves and fittings. Remove the knobs, then remove the 4 screws which fasten the valve panel to the unit (you will need a torx head for this). Pull the valve panel outward and unplug the wires from the back of the push button. If your grill has the optional rotis burner, remove the screws which hold the inspection cover in place.

## TO TEST:

Make sure all control valves are in the "OFF" position. Turn the gas supply "ON". Check all

connections from the supply line, or LP cylinder up to and including the manifold pipe assembly. Apply the soap solution around the connection, valve and tubing. Soap bubbles will appear where a leak is present. If a leak is present, immediately turn off gas supply, tighten any leaking fittings, turn gas on, and recheck. Check all the gas connections at the base of the control valves where they screw into the manifold pipe.

To check rotis burner and safety valve the burner must be lit, then leak test the connections located under the safety cover. If you cannot stop a gas leak, turn off the gas supply and call your local gas utility, or the dealer you purchased the appliance from. Only those parts recommended by the manufacturer should be used on the Grill. Substitution can void the warranty.

**Do not use the grill until all connections have been checked and do not leak.**

*Check all gas supply fittings for leaks before each use. It is handy to keep a spray bottle of soapy water near the shut-off valve of the gas supply valve. Spray all the fittings. Bubbles indicate leaks.*

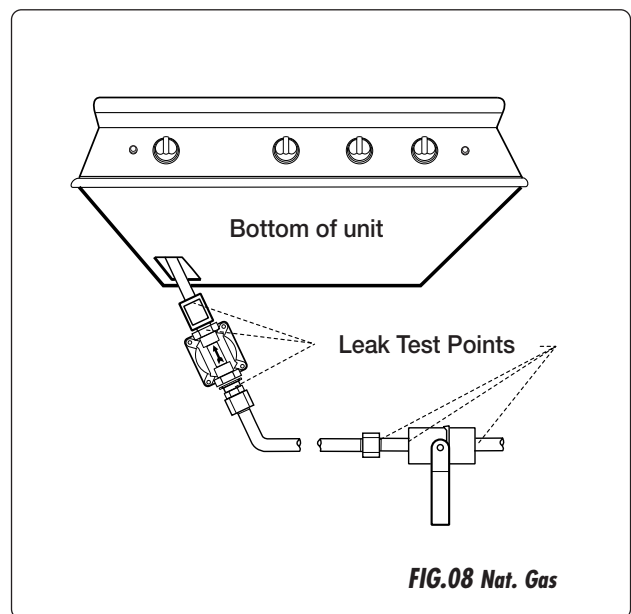
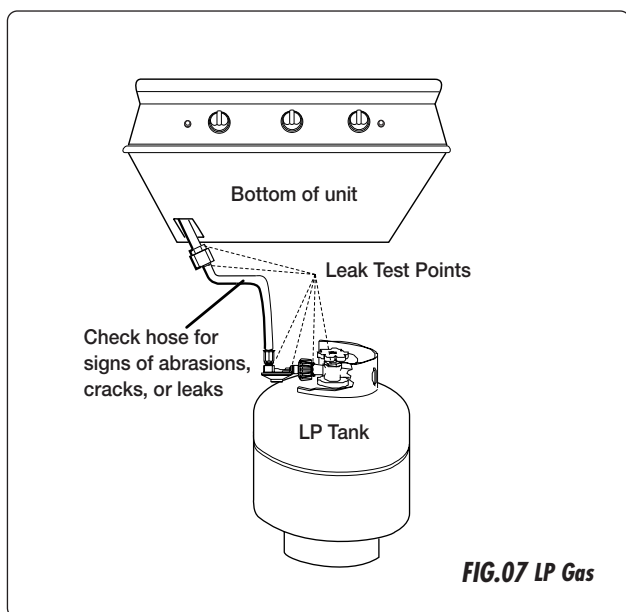

# Installer Checklist/Burner Adjustments

## INSTALLER FINAL CHECKLIST:

- |   |  |   |
|---|--|---|
| <input type="checkbox"/> Specified clearances maintained to combustibles.                             | <input type="checkbox"/> Air shutters adjusted.  | <input type="checkbox"/> User informed of gas supply shut-off valve location. |
| <input type="checkbox"/> Nylon straps removed from burners.   | <input type="checkbox"/> Adjustable low setting satisfactory.  | • PLEASE LEAVE THESE INSTRUCTIONS WITH THE USER.                              |
| <input type="checkbox"/> All internal packaging removed.  | <input type="checkbox"/> Drip pan in place properly and sliding freely.                                |   |
| <input type="checkbox"/> Knobs turn freely, bezels centered.  | <input type="checkbox"/> Pressure regulator connected and set for 4.0"W.C. Natural, 11.2" W.C. LP gas. | • USER, PLEASE RETAIN THESE INSTRUCTIONS FOR FUTURE REFERENCE.                |
| <input type="checkbox"/> Each burner lights satisfactorily, individually or with adjacent burner lit. | <input type="checkbox"/> Manual shut-off valve installed and accessible.                               |   |
|   | <input type="checkbox"/> Unit tested and free of leaks.  |   |

## GRILL BURNER FLAME HEIGHT:

To access the grill burner air shutters first remove the valve panel by removing the four screws on the corners of the valve panel. Remove the control knobs. Pull the valve panel outward. With a screw driver, loosen the lock-screw on the face of the air shutter. Light the burner and adjust according to the directions above. Access for the power burner air shutters is through the top after removing the top burner grate (See Fig. 09).

## BURNER AIR ADJUSTMENT:

Each grill burner is tested and adjusted at the factory prior to shipment; however, variations in the local gas supply or a conversion from one gas to another may make it necessary to adjust the burners. The flames of the burners (except the rotisserie burner) should be visually checked and compared to that of the drawing in Fig.09. Flames should be blue and stable with no yellow tips, excessive noise or lifting. If any of these conditions exist, check if the air shutter or burner ports are blocked by dirt, debris, spider webs, etc. Proceed with air shutter adjustment. The amount of air which enters a burner is governed by a sheet metal cup or disk at the inlet of the burner called an air shutter. It is locked in place by a set screw which must be loosened prior to lighting the burner for adjustment.

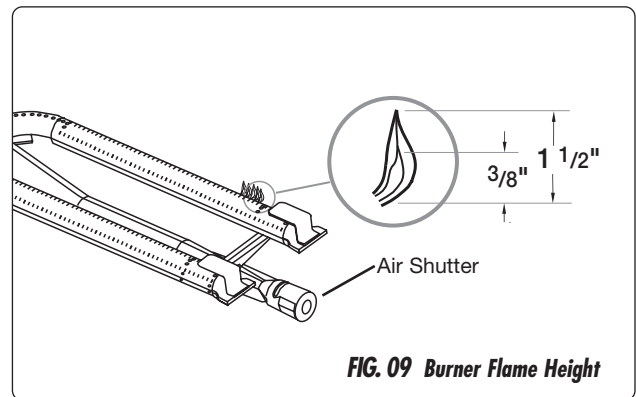

**FIG. 09** Burner Flame Height

## Burner Adjustments / Using The Grill

**WARNING: IMPORTANT!** Before lighting, inspect the gas supply piping or hose prior to turning the gas "on". If there is evidence of cuts, wear, or abrasion, it must be replaced prior to use.

### TO ADJUST:

1. Be careful as the burner may be very hot.
2. If the flame is yellow, indicating insufficient air, turn the air shutter counterclockwise to allow more air to the burner.
3. If the flame is noisy and tends to lift away from the burner, indicating too much air, turn the air shutter clockwise.
4. Once adjusted turn the burner off and reverse steps to reassemble.

### LOW SETTING ADJUSTMENTS:

The valves on the grill feature an adjustable low setting. Due to fluctuations in gas pressure, heating value or gas conversion, you may feel it necessary to increase or decrease gas flow in the low position. We do not recommend adjusting the infrared rotis burner.

### TO ADJUST:

1. Light the burner.
2. Turn the control knob to the lowest setting (all the way counter-clockwise).
3. Remove the knob.
4. While holding the valve shaft with pliers, insert a thin, flat tipped screwdriver into the shaft and while viewing the burner adjust to a minimum stable flame (Fig. 10).

### GRILL:

Each grill section consists of a large stainless steel burner, a series of stainless steel heat baffles, a series of pyramid rocks encased in a stainless steel rack, and a stainless steel heat retaining cooking rack. Each burner is rated at 20,000 Btu/hr. Below each burner is a stainless steel heat baffle which

reflects usable heat upward into the cooking area and reduces temperatures of the drip pan below. Above the burners are stainless steel radiants which encase the ceramic tubes and protect the grill burner ports from blockage.

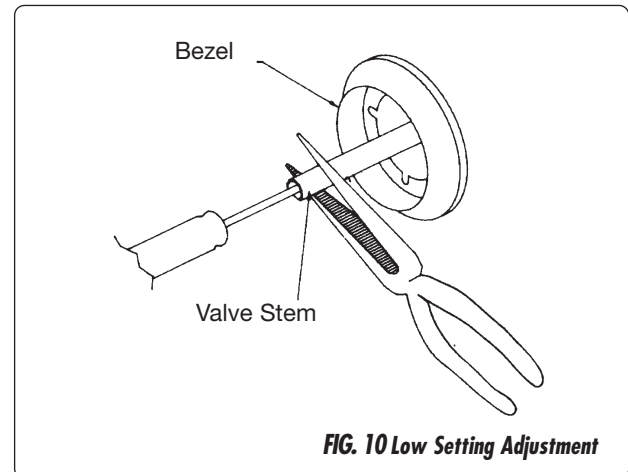

**FIG. 10 Low Setting Adjustment**



## Using The Grill

The replacement pressure regulators and hose assembly must be the type specified by the manufacturer. Do not use the grill if the odor of gas is present. The pressure regulator and hose assembly supplied with the unit must be used. If the unit is LP, screw the regulator into the tank and leak check the hose and regulator connections with a soap and water solution before operating the grill. Turn all knobs to "OFF" then turn on the gas supply. If LP, is there gas in the tank? Always keep your face and body as far away from the grill as possible when lighting.

- DO NOT leave the grill unattended while cooking.
- Keep a spray bottle of soapy water near the gas supply valve and check the connections before each use.
- Do not attempt to light the grill if the odor of gas is present.
- Wait 5 minutes before relighting a hot grill.

### GRILLING HINTS:

The doneness of meat, whether rare, medium, or well done, is affected to a large degree by the thickness of the cut. Expert chefs say it is impossible to have a rare doneness with a thin cut of meat. The cooking time is affected by the kind of meat, the size and shape of the cut, the temperature of the meat when cooking begins, and the degree of doneness desired. When defrosting meats it is recommended that it be done overnight in the refrigerator as opposed to a microwave. This in general yields a juicier cut of meat. Use a spatula instead of tongs or a fork to turn the meat, as a spatula will not puncture the meat and let the juices run out. To get the juiciest meats, add seasoning or salt after the cooking is finished and turn the meat only once (juices are lost when the meat is turned several times). Turn the meat just after the juices begin to bubble to the surface. Trim any excess fat from the meat before cooking. To prevent steaks or chops from curling during cooking, slit the fat around the edges at 2-inch intervals.

**Note:** The hot grill sears the food, sealing in the juices. The longer the preheat, the faster the meat browns and the darker the grill marks.

### USING THE GRILL NATURAL GAS:

Grilling requires high heat for searing and proper browning. Most foods are cooked at the "MEDIUM" heat setting for the entire cooking time. However, when grilling large pieces of meat or poultry, it may be necessary to turn the heat to a lower setting after the initial browning. This cooks the food through without burning the outside. Foods cooked for a long time or basted with a sugary marinade may need a lower heat setting near the end of the cooking time.

1. Check to be certain the drip tray is in place.
2. Light the grill burners using the instructions on pages 16-17.
3. With the grill lid open, turn the control knob to "HI" and preheat the grill for 15 minutes. The grill lid is to be closed during the appliance preheat period.
4. Place the food on the grill and cook to the desired doneness. Adjust heat setting, if necessary. The control knob may be set to any position between "HI" and "LO".
5. Allow grill to cool and clean the drip tray after each use.

## Using The Grill / Lighting Instructions

### USING THE GRILL LP GAS:

**Note:** Your preheat time may be shorter than recommended when using LP gas. To prevent overcooking you may want to lower heat settings.

Grilling requires high heat for searing and proper browning. Most foods are cooked at the “Medium” heat setting for the entire cooking time. However, when grilling large pieces of meat or poultry, it may be necessary to turn the heat to a lower setting after the initial browning. This cooks the food through without burning the outside. Foods cooked for a long time or basted with a sugary marinade may need a lower heat setting near the end of the cooking time.

1. Check to be certain the drip tray is in place.
2. Light the grill burners using the instructions on page 16-17.
3. Turn the control knob to “HI”. Once the burner is lit, typical preheat time for grills using LP gas is 5 to 10 minutes. The grill lid is to be closed during the appliance preheat period.
4. Place the food on the grill and cook to the desired doneness. Adjust heat setting, if necessary. The control knob may be set to any position between “HI” and “LO”.
5. Allow grill to cool and clean the drip tray after each use

**Grilling Method Note:** *Indirect cooking method is a popular alternative to direct heat grilling. Indirect cooking uses heat from adjacent burners to cook food and in many cases, reduces the possibility of overcooked or overly browned food. Foods most appropriate for indirect grilling included breads, thicker pieces of chicken or steaks.*

### Direct Heat Grilling (Hot Dogs, Hamburgers, Typical Thickness Steaks/Chicken)

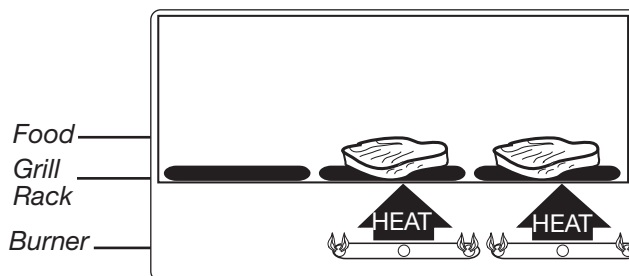

### Indirect Heat Grilling

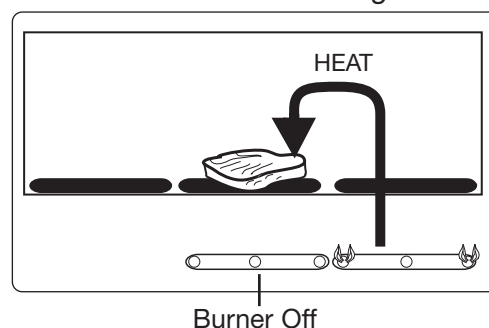

### TO LIGHT THE GRILL BURNER:

**Note:** Open the grill cover and/or remove the top grate cover before lighting. Turn all knobs to “OFF”. Turn the main gas supply on. If you smell gas, shut-off gas supply and call for service.

Push and hold the ignition button, turn the selected burner knob to “HI”. If burner does not light in 4 to 5 seconds turn knob “OFF” and wait 5 minutes before trying again for any accumulated gas to dissipate.

## Lighting Instructions

### MANUAL LIGHTING:

If the burner will not light after several attempts then the burner can be manually lit. If you've just attempted to light the burner with the igniter, allow 5 minutes for any accumulated gas to dissipate. Keep your face and hands as far away from the grill as possible and hold and pass a lit match or butane lighter over the hole located on the top left for burner on the left, or the right hole for the right burner (see Fig.11). Push and turn the control knob which is centered on the burner that you intend to light to "HI". If the burner does not light

in 4 seconds turn the knob off, wait 5 minutes and try again. Once the left or right burner is lit, the adjacent burner(s) can be lit by the cross-lighting method. For center burners to cross light, light the adjacent far left or right burner using the standard or manual light procedure. Push and turn the control knob for the desired center burner to "HI"; the gas will be ignited by the adjacent burners flame. If the burner does not light in 4 seconds, turn knob off, wait 5 minutes and try again.



## Using The Rotisserie

### **BQR AND BQAR MODELS ONLY:**

The grill rotisserie system is designed to cook items from the back using infrared heat. The location of the burner allows the placement of the rotis basting pan (included) beneath the food to collect juices and drippings for basting and gravy. To flavor the contents of the basting pan, you can add herbs, onion, garlic, or spices. Hams are especially good with the addition of pineapple slices and brown sugar to the basting pan. The rotisserie burner is an infrared type which provides intense searing radiant heat. Preferred by chefs over other methods, this intense heat is magnificent for searing in the natural juices and nutrients found in quality cuts of meat.

Once lit, the rotis burner will reach cooking temperatures in about 1 minute. The orange/red glow will even out in about 5 minutes. The rotis motor is equipped with metal gears and is capable of turning up to a 25 lb. cut of meat or poultry. The motor is mounted to a metal channel which attaches to the left side of the grill (see Fig.12).

The rotis motor on the grills is secured. The skewer for the rotis is assembled into the motor assembly by placing the pointed end into the motor, and resting the threaded end on the support at the right side of the grill. With the skewer pushed as far as possible into the motor, the grooved skewer bushing should rest on the right side bracket.

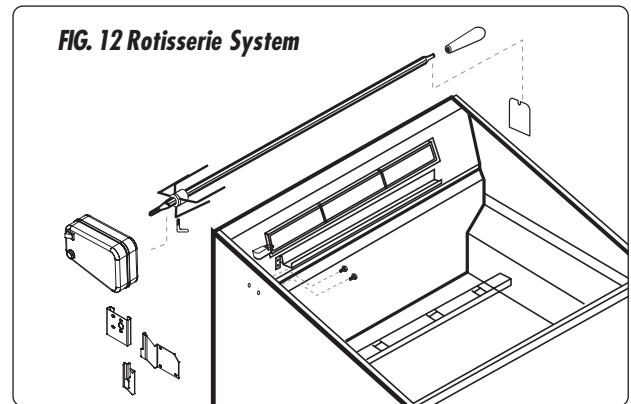

To load the skewer begin with the handle in place, and slide one of the meat holders (prongs facing away from the handle) onto the skewer. Push the skewer through the center of the food, then slide the second meat holder (prongs toward the food) onto the skewer. Center the product to be cooked on the skewer then push the meat holders firmly together. Tighten the L shape nut with pliers. It may also be necessary to wrap the food with butchers string or dental floss (never use nylon or plastic string) to secure any loose portions. Once the food is secure insert the skewer into the motor. If needed, remove the grill racks. Place a basting pan beneath the food. It is normal for the skewer to flex when larger cuts of meat are being cooked.

## Using The Rotisserie

### TO LIGHT THE ROTISSERIE BURNER (BQR AND BQAR MODELS ONLY):

The location of the rotis burner makes it more susceptible to strong wind conditions, more so than the protected grill burners. For this reason you should avoid operating the rotis during windy conditions. As an added safety feature we've equipped the burner with an automatic safety valve which will not allow gas to flow to the rotis burner unless the following conditions are present with the knob on:

1. The safety valve button is pressed and held down.
2. The safety valve thermocouple has been sufficiently heated to keep safety valve open.

Open the lid. Push and hold the ignition button. You'll hear a snapping sound. Turn the control knob to 'HI'. Engage the safety valve button and continue to hold until the burner is lit. Once lit, turn control knob to desired setting. If the burner does not light within 4 to 5 seconds, release the safety valve button and turn the control knob to "OFF" and wait 5 minutes before trying again.

- If relighting a hot burner, wait 5 minutes.
- Never leave the control knob on if rotis is not in use.
- Never light a grill burner under the rotis, while rotisserie burner is lit.

### MANUAL LIGHTING:

To manually light the rotisserie, place a butane lighter near the tip of the thermocouple as shown in Fig. 13. Turn the control knob to "HI". Hold the safety valve button in for about 4 to 5 seconds or until the burner remains lit. Once lit, turn control knob to desired setting. If the burner does not light within 4 or 5 seconds, release the safety valve button and turn the control knob to "OFF" and wait 5 minutes before trying again.

**WARNING:** Keep hands and face away from front of burner! **Stand to the side when lighting. Once lit move hand away quickly.**

**WARNING: Electrical Grounding Instructions:** This appliance (rotisserie motor) is equipped with a three-prong (grounding) plug for your protection against shock hazard and should be plugged directly into a properly grounded three-prong receptacle. Do not cut or remove the grounding prong from this plug.

The Rotisserie motor must be electrically grounded in accordance with local codes or, in the absence of local codes, with the National Electrical Code, ANSI/NFPA 70-1990. Keep the rotis motor electric cord away from the heated surfaces of the grill. When not in use, remove and store the motor in a dry location.



## Care And Cleaning

### BATTERY REPLACEMENT:

1. Remove grease tray.
2. Open cart door.
3. Pull battery downwards (This may require use of pliers.)

**Note:** Re-install upward and push to snap.

**Note:** Polarity as shown in Fig. 14.

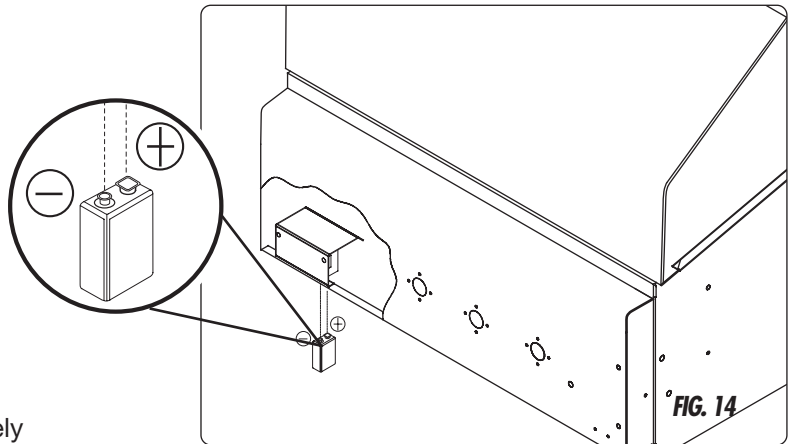

### GRILL RACKS:

The easiest way to clean the grill is immediately after cooking is completed and after turning off the flame. Wear a barbeque mitt to protect your hand from the heat and steam. Dip a fine brass bristle barbeque brush in tap water and scrub the hot grill. Dip the brush frequently in the bowl of water. Steam, created as water contacts the hot grill, assists the cleaning process by softening any food particles. The food particles will fall and burn or fall into the drip tray. If the grill is allowed to cool before cleaning, cleaning will be more difficult.

**Note:** Stainless steel tends to rust in presence of chlorides and sulfides specially in coastal areas. To ensure rust prevention, wash all stainless steel surfaces every 3-4 weeks with fresh water and stainless cleaner.

### DRIP TRAYS:

The full width drip trays will collect grease from the grill section and boil overs and spills from the power burners. Allow the pan and its contents to cool before attempting to clean. Clean grease from the pan often to avoid the possibility of a grease fire.

### STAINLESS STEEL:

The Grill is made from non-rusting and non-magnetic stainless steel. After initial usage, areas of the grill may discolor from the intense heat given off by the burners, this is normal. There are many different stainless steel cleaners available. Always use the mildest cleaning procedure first, scrubbing in the direction of the grain. To touch up noticeable scratches in the stainless steel, sand very lightly with dry 100 grit emery paper in the direction of the grain. Specks of grease can gather on the surfaces of the stainless steel and bake on to the surface and give the appearance of rust. For removal use an abrasive pad (Scotch Brite is good) in conjunction with a stainless steel cleaner. Always rub in the direction of the grain.



## Burner Removal And Cleaning

### GRILL AND ORIFICE CLEANING:

Remove the grill racks, then lift out the grill radiant tray. Grasp the burner, pull it up and slightly to the rear of the unit so the burner head comes off the brass orifice at the front, angle the burner sideways, and remove.

### Burner Cleaning

Clean the exterior of the burner with a wire brush. Clear stubborn scale with a metal scraper. Clear any clogged ports with a straightened paper clip. Never use a wooden toothpick as it may break off and clog the port. Shake out any debris through the air shutter. Use a flashlight to inspect the burner inlet to ensure it is not blocked. If obstructions can be seen, use a metal wire coat hanger that has been straightened out.

### Orifice Cleaning

With the burner removed, remove the orifice and shine a flashlight through the opening to ensure there is no blockage. Use a needle to clear any debris. Be extremely careful not to enlarge the hole or break off the needle (see Fig. 15).

*IT IS EXTREMELY IMPORTANT TO CENTER THE BURNER ON THE ORIFICE PROPERLY.*

Be careful not to upset the air shutters' original position (unless readjusting). Lower the rear of the burner into the cutouts on the support channel at the rear of the burner box. Make sure it is level and does not rock. Light all of the burners and check for proper flame characteristics. If adjustments are necessary, refer to page 13. Do this prior to cooking on the grill.

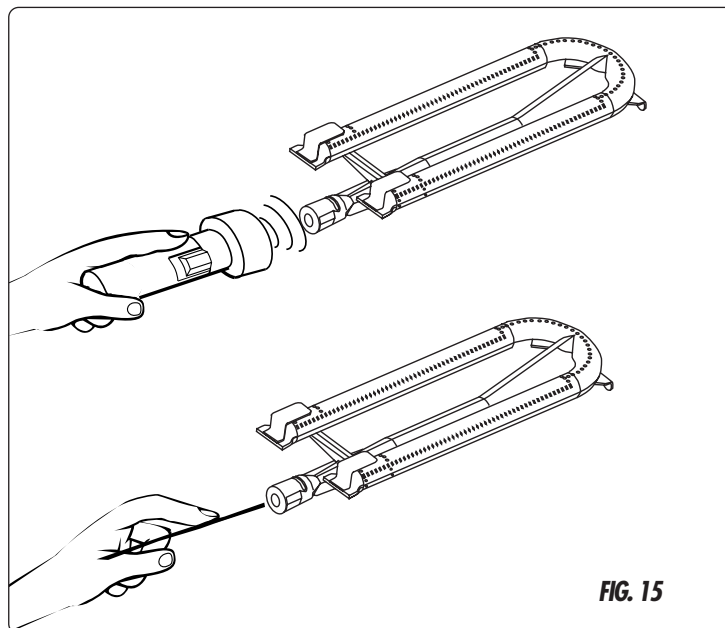

**FIG. 15**



# Troubleshooting

## **BEFORE CALLING FOR SERVICE:**

If the grill does not function properly, use the following checklist before contacting your dealer for service. You may save the cost of a service call. Troubleshooting is for general purposes only. If the problem persists and you feel you require service, contact your dealer or the nearest authorized agency to perform service. Only authorized agencies can perform warranty service. Call Customer Service at 877-553-0243.

### **Grill won't light when the ignition button is pushed:**

1. Remove the grill top grates and the radiant trays, watch the electrode tip. You should see a spark jump from the tip of the electrode when the ignition button is pushed.
2. If there is no spark when ignition button is pushed, check the battery condition.
3. Attempt to manual light the burner, (see page 17) check to see that other burners on the unit operate. Clean ignition tip of any debris.

### **Burner flame is yellow or orange, in conjunction with the odor of gas:**

1. Check the burner inlet for obstructions such as spider webs. Check the air shutter for proper adjustment.
2. Grill may be in a dusty area. Move to less dusty area if possible.

### **Low heat with knob in "HI" position:**

1. If only one of the burners appears low, clean the orifice and burner, clearing ports of any obstruction (see page 21).
2. Grill may be in a dusty area. Move to less dusty area if possible.
3. Check for proper gas supply and pressure.
4. Pre-heat grill for a full 15 minutes.
5. If using LP gas check for empty tank.

### **Optional rotis won't light:**

1. Is there a spark at the thermocouple?
2. Does the rotis burner light when attempting to manual light?

### **Optional rotis lights, but will not hold flame once button is released:**

1. Continue holding safety valve button in depressed position until burner remains lit when released.

# Grill Burner Assembly-27"

ITEM	DESCRIPTION	PART NO.
1	Grill Rack S/S 27	19014-02
2	Radiant	32889
3	Pyramid Rock	10436
4	27"C/ Heat Shield w/Assy.	32220
5	SS Grill Burner	12285
6	Air Shutter Screw	12003-2
7	27" Heat Shield	32336

ITEM	DESCRIPTION	PART NO.
8	Manifold 27	18034-01
9	Control Valve	13017
10	Control Knob	18445
11	Knob Bezel	14006-PL
12	Collector Box	32801
13	NI-Chrome Wire Coil	32313
14	Burner Electrode L/H	16281-02
	Burner Electrode R/H	16281-03
15	Screw	15001-28
16	Bracket, Ignition Module, Eltec4	30991
17	Ignition Module 2 Outputs (BQ Mod)	18349
	Ignition Module 4 Outputs (BQR Mod)	18350
18	Bezel Screw	15001-29
19	Manifold Bolt	15001-06
20	Regulator (LP GAS)	13230
21	Regulator (NAT. GAS)	13035
22	Alkaline 9V Battery	18354

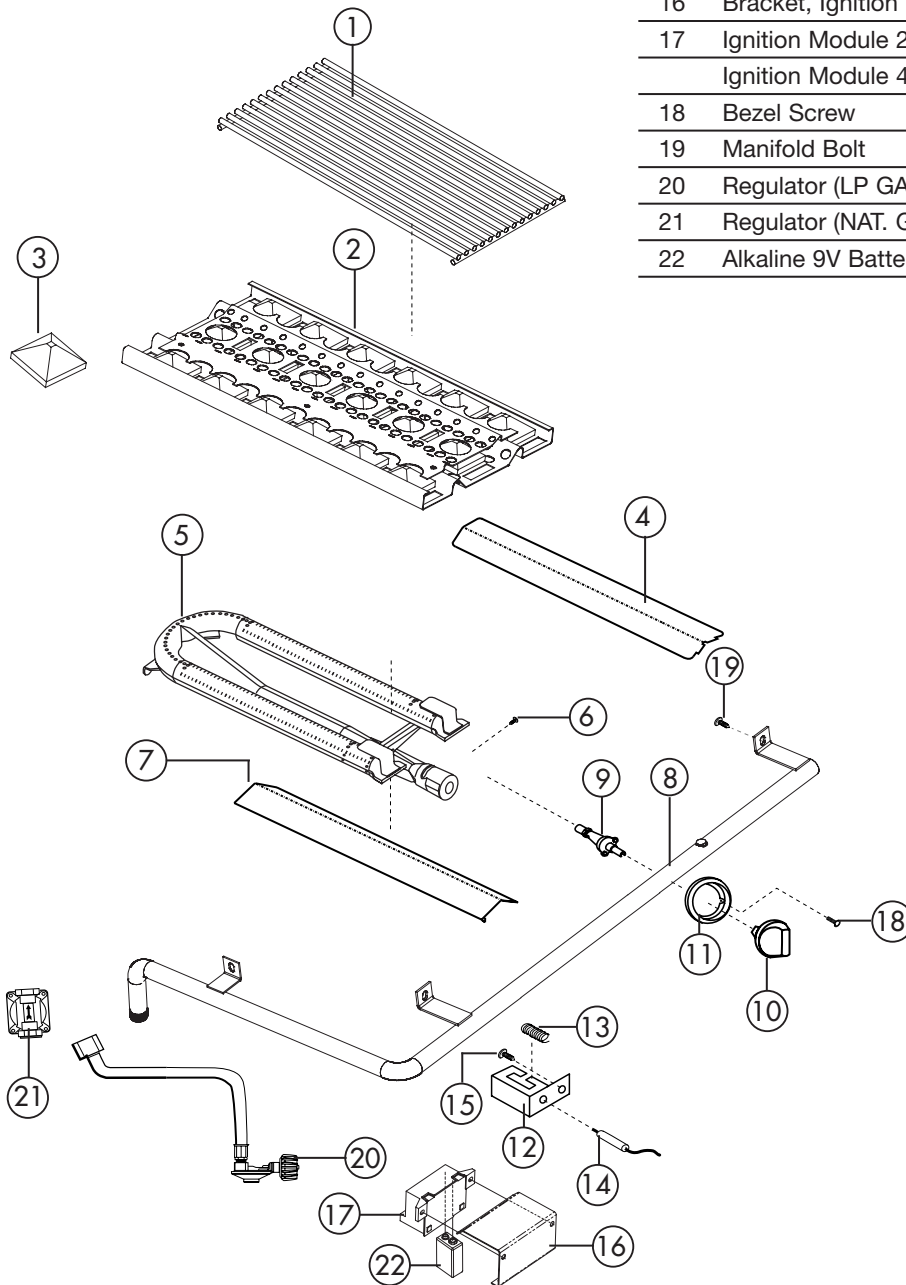

# Grill Body Parts List-27"

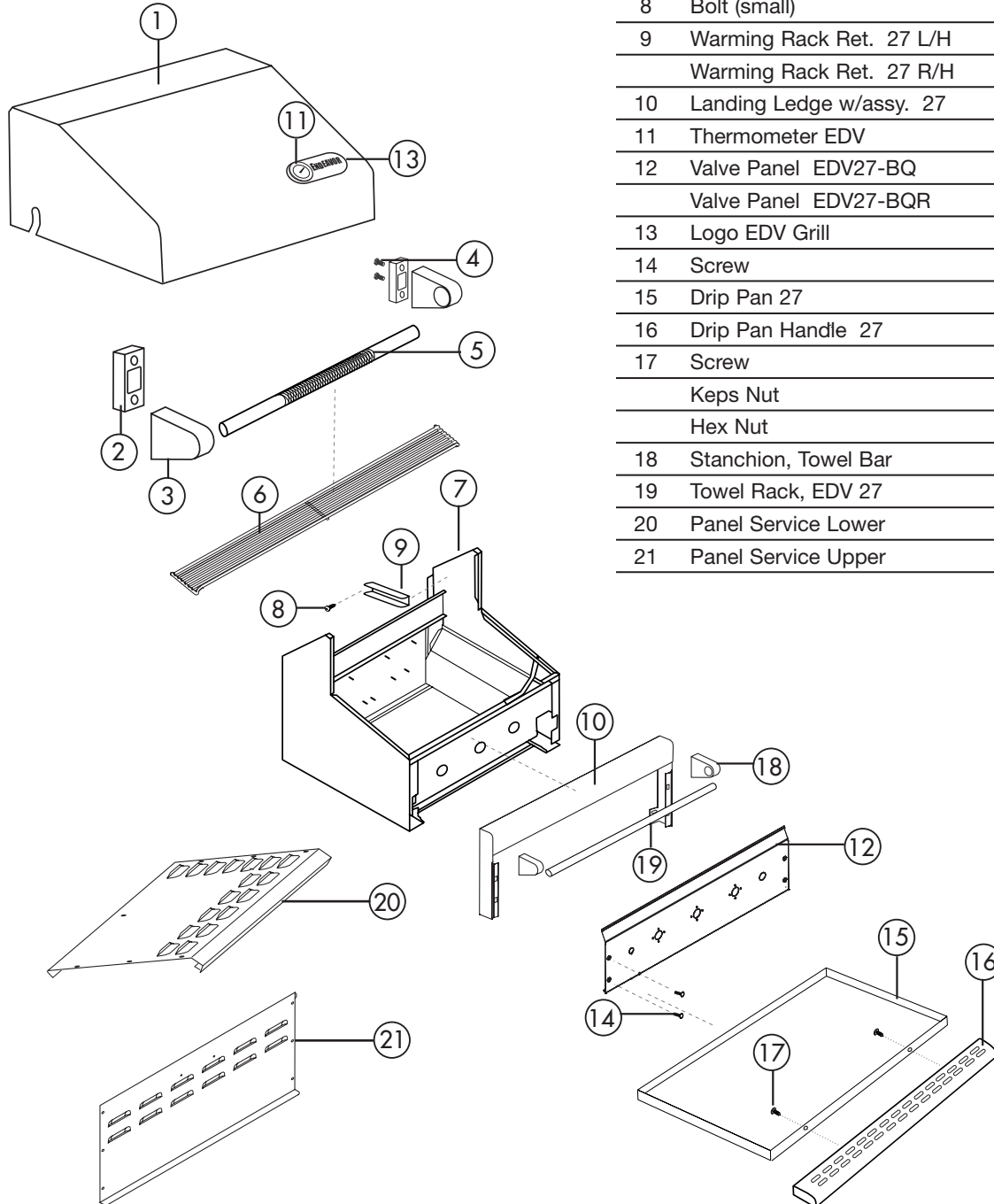

ITEM	DESCRIPTION	PART NO.
1	Folding Lid w/assy. EDV27	32882-01
2	Handle End Cap Spacer	18446
3	Handle End Cap	18443-PL
4	Shoulder Bolt	15003-15
5	Handle Lid	32886-01
6	Warming Rack Galore 27	18444
7	Body Assembly 27 EDV Grill	38848-01
8	Bolt (small)	15002-26
9	Warming Rack Ret. 27 L/H	32340-01
	Warming Rack Ret. 27 R/H	32340-02
10	Landing Ledge w/assy. 27	32871-01
11	Thermometer EDV	13392
12	Valve Panel EDV27-BQ	32857-01-PA
	Valve Panel EDV27-BQR	32857-PA
13	Logo EDV Grill	17523
14	Screw	15002-32
15	Drip Pan 27	32260
16	Drip Pan Handle 27	32897
17	Screw	15002-17
	Keps Nut	15021-04
	Hex Nut	15004-09
18	Stanchion, Towel Bar	18442-PL
19	Towel Rack, EDV 27	32887-01
20	Panel Service Lower	32270
21	Panel Service Upper	32269

# Rotisserie Assembly-27"

ITEM	DESCRIPTION	PART NO.
1	Rotisserie Handle	18040
2	Meat Holder Assembly	19010-02
3	Rotisserie Rod 27	19487-01
4	Rotis Receiving Bracket	32846
5	Rotisserie Burner 27dbqar	12021-2
6	Orifice Elbow	18193
7	Plug Orifice LP	13025-56
	Plug Orifice NG	13025-50
8	Screws	15001-23
9	Rotisserie Motor	16026
10	Rotis Motor Bracket	32845
11	Rotis Body Bracket Small	40127-02
12	Rotis Body Bracket Large	40127-01
13	Thermocouple	13007-2

ITEM	DESCRIPTION	PART NO.
14	Electrode Rotisserie	16282-01
15	Electrode Housing	32941
16	Flavor Tray	32294
17	Manifold Bolt	15001-06
18	Tubing Manifold Safety Valve	32914
19	Safety Valve	18110
19a	Ferrule	18077-2
20	Tubing Safety Valve-I/R	32915
21	Safety Valve Bezel	14160
22	Safety Valve Knob	14108
23	Control Knob	18445
24	Knob Bezel	14006-PL
25	Control Valve	13017
26	Manifold 27	18034-01

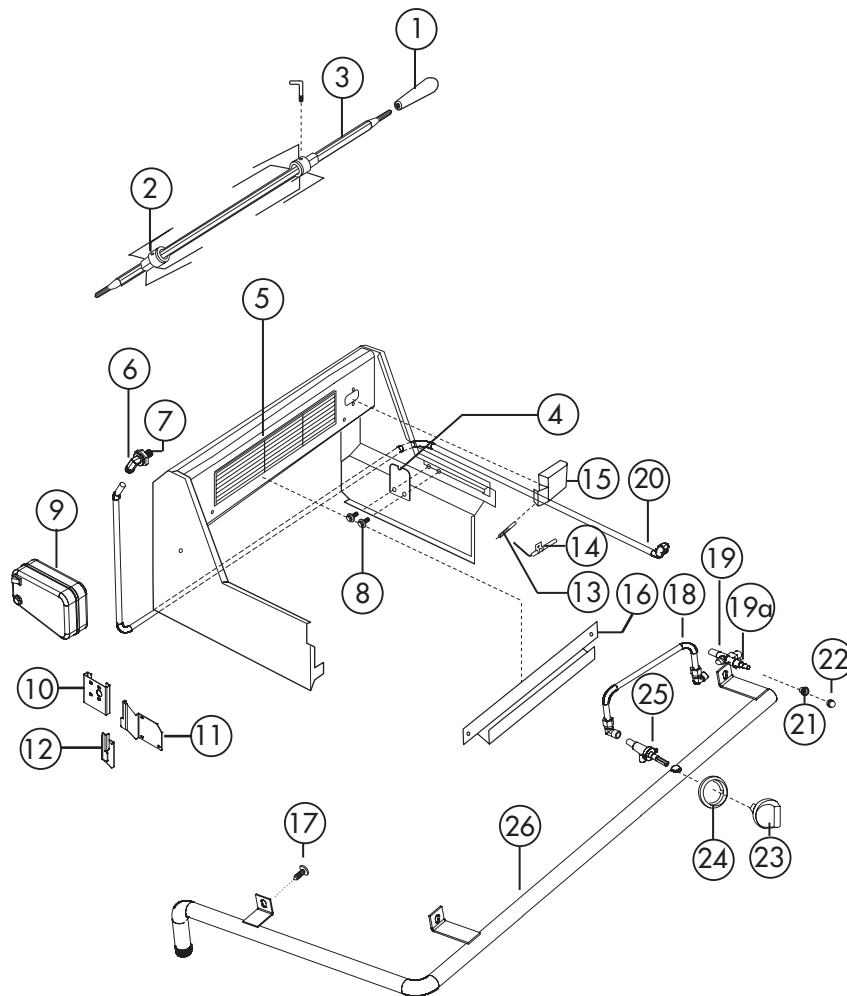



# Grill Body Parts List-36"

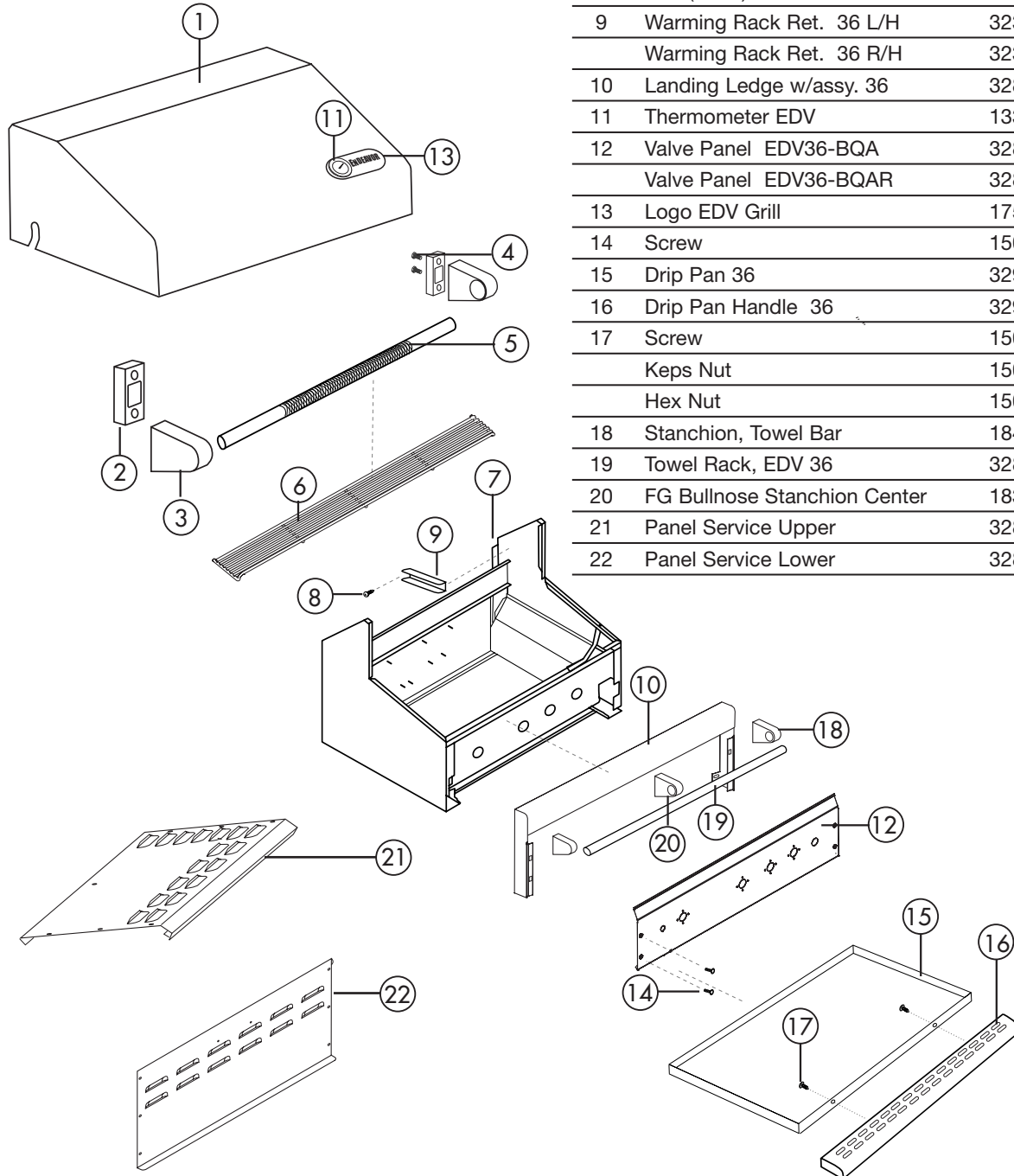

ITEM	DESCRIPTION	PART NO.
1	Folding Lid w/assy. EDV36	32882-02
2	Handle End Cap Spacer	18446
3	Handle End Cap	18443-PL
4	Shoulder Bolt	15003-15
5	Handle Lid	32886-02
6	Warming Rack Galore 36	18444-01
7	Body Assembly 36 EDV Grill	38848-02
8	Bolt (small)	15002-26
9	Warming Rack Ret. 36 L/H	32340-01
	Warming Rack Ret. 36 R/H	32340-02
10	Landing Ledge w/assy. 36	32871-02
11	Thermometer EDV	13392
12	Valve Panel EDV36-BQA	32858-01-PA
	Valve Panel EDV36-BQAR	32858-PA
13	Logo EDV Grill	17523
14	Screw	15002-32
15	Drip Pan 36	32902
16	Drip Pan Handle 36	32900
17	Screw	15002-17
	Keps Nut	15021-04
	Hex Nut	15004-09
18	Stanchion, Towel Bar	18442-PL
19	Towel Rack, EDV 36	32887-02
20	FG Bullnose Stanchion Center	18317-PL
21	Panel Service Upper	32876
22	Panel Service Lower	32877

# Rotisserie Assembly-36"

ITEM	DESCRIPTION	PART NO.
1	Rotisserie Handle	18040
2	Meat Holder Assembly	19010-02
3	Rotisserie Rod 36	19487-02
4	Rotis Receiving Bracket	32846
5	Rotisserie Burner 36dbqar	12021-2
6	Orifice Elbow	18193
7	Plug Orifice LP	13025-56
	Plug Orifice NG	13025-50
8	Screws	15001-23
9	Rotisserie Motor	16026
10	Rotis Motor Bracket	32845
11	Rotis Body Bracket Small	40127-02
12	Rotis Body Bracket Large	40127-01
13	Thermocouple	13007-2

ITEM	DESCRIPTION	PART NO.
14	Electrode Rotisserie	16282-01
15	Electrode Housing	32941
16	Flavor Tray	32844
17	Manifold Bolt	15001-06
18	Tubing Manifold Safety Valve	32909
19	Safety Valve	18110
19a	Ferrule	18077-2
20	Tubing Safety Valve-I/R	32910
21	Safety Valve Bezel	14160
22	Safety Valve Knob	14108
23	Control Knob	18445
24	Knob Bezel	14006-PL
25	Control Valve	13017
26	Manifold 36	18447

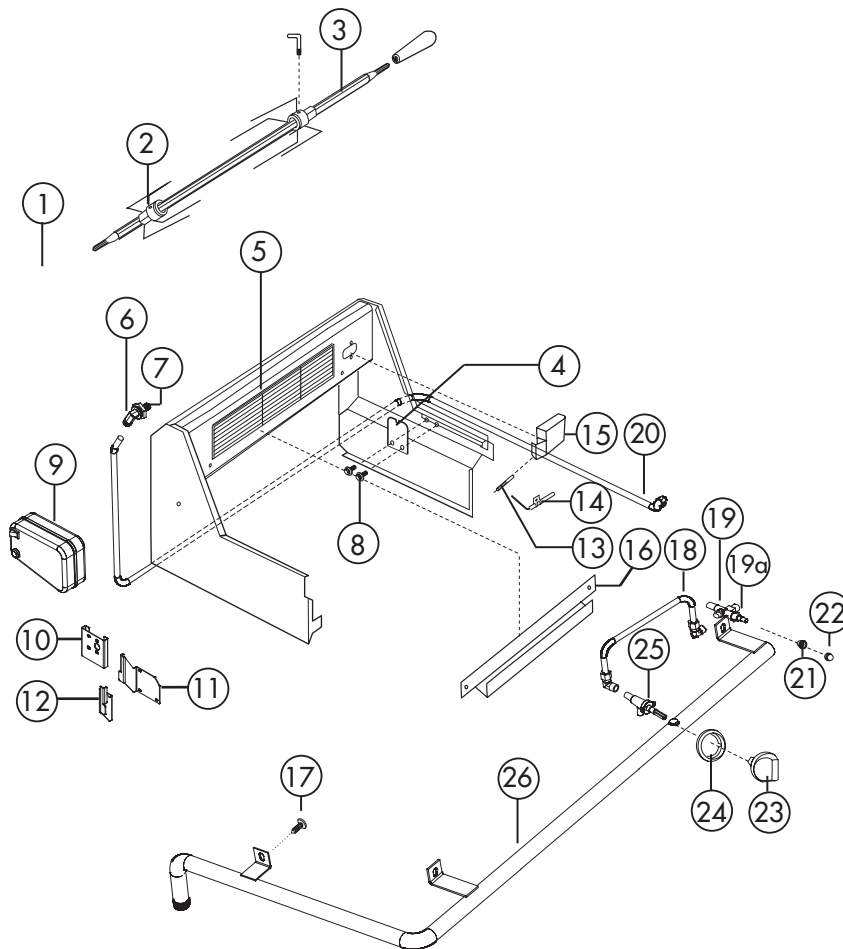



# Cart Assembly 27" & 36"

ITEM	DESCRIPTION	PART NO.
1	Side Panel L/H	32906
2	Front Panel-36"	32864-02
	Front Panel-27"	32864-01
3	Bottom Cart L/H Shelf	32921
4	Door Assembly-36'	32905
	Door Assembly-27"	32874
5	Caster Locking 3	18027
6	Caster Stiffner	41109
7	Caster without Brake 3	18027-1
8	Bottom Cart R/H Shelf	32918

ITEM	DESCRIPTION	PART NO.
9	Side Panel R/H	32866
10	Rear Panel-36"	32865-02
	Rear Panel-27"	32865-01
11	Rear Brace-36"	32844
	Rear Brace-27"	41107
12	Rubber Bumper	18403
13	Snap Bushing	14088
14	Bottom Panel-36"	32863-02
	Bottom Panel-27"	32863-01

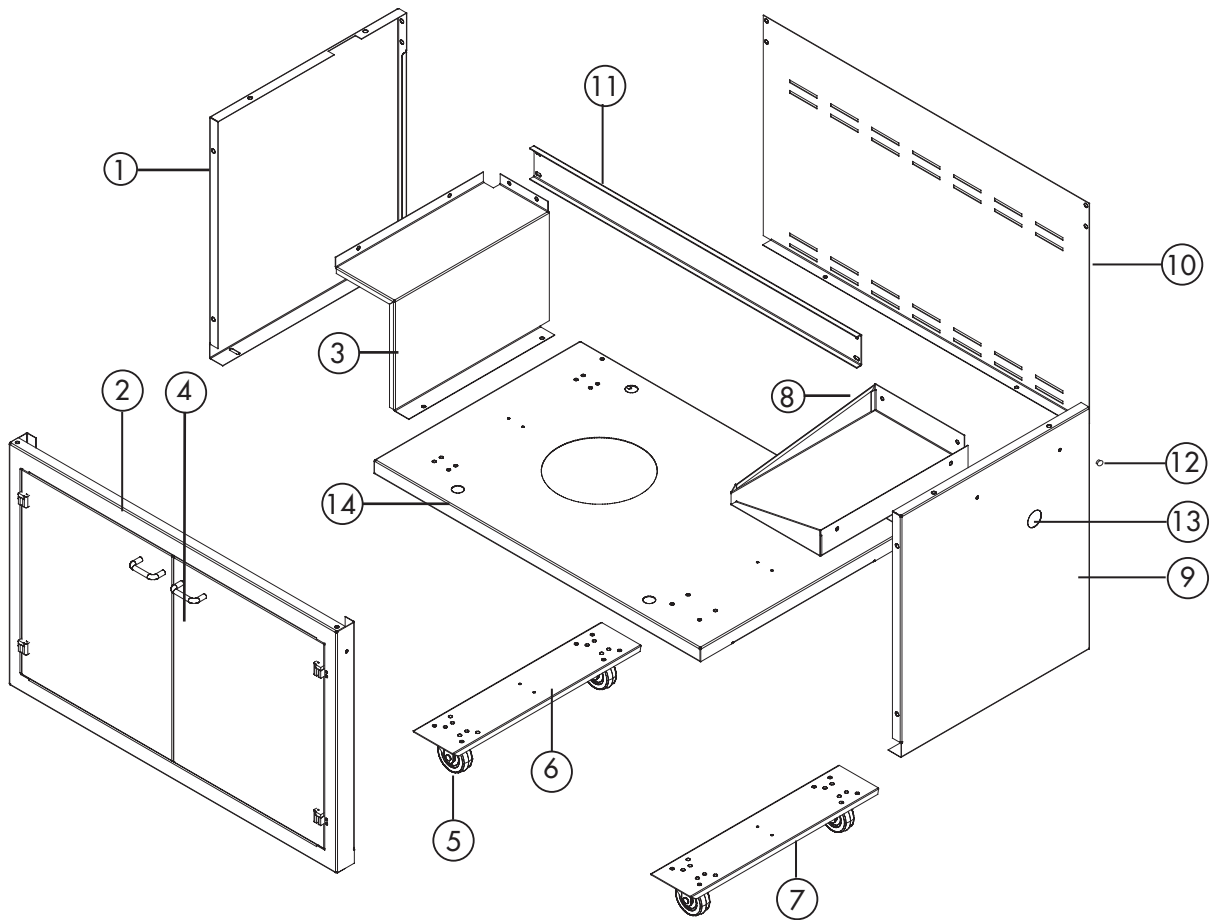
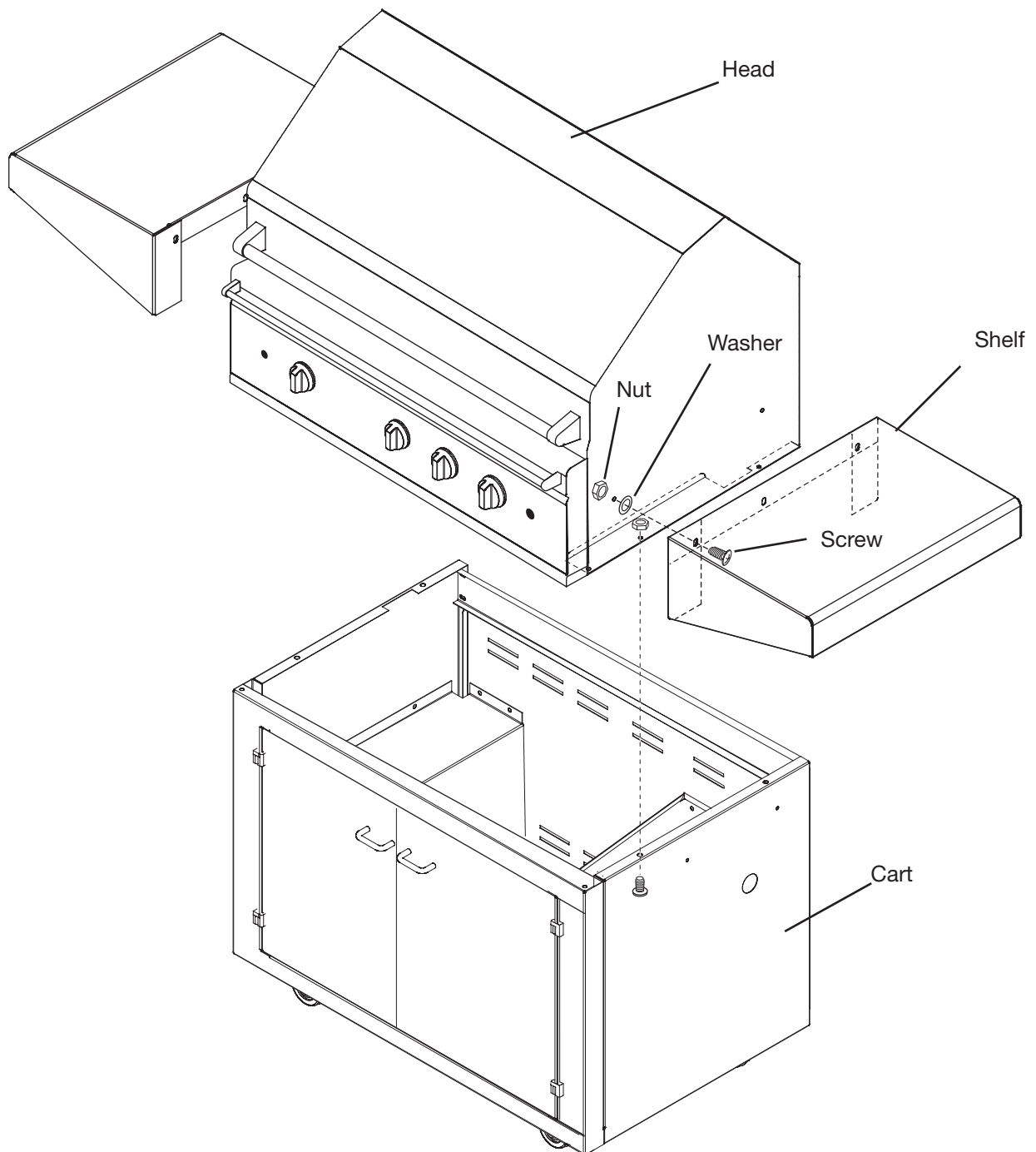

Diagram of 36" Cart

## Head and Cart Assembly

1. Put Cart on a flat surface.
2. Install Head on the Cart (2 people required to lift Head).
3. Using bolt and nut (6 required), attach Head to the Cart.
4. Install shelves to the side of the Head with bolt and nut (8 required), putting washers between Head and Shelves.



# Wiring Diagram for EDV27-BQ

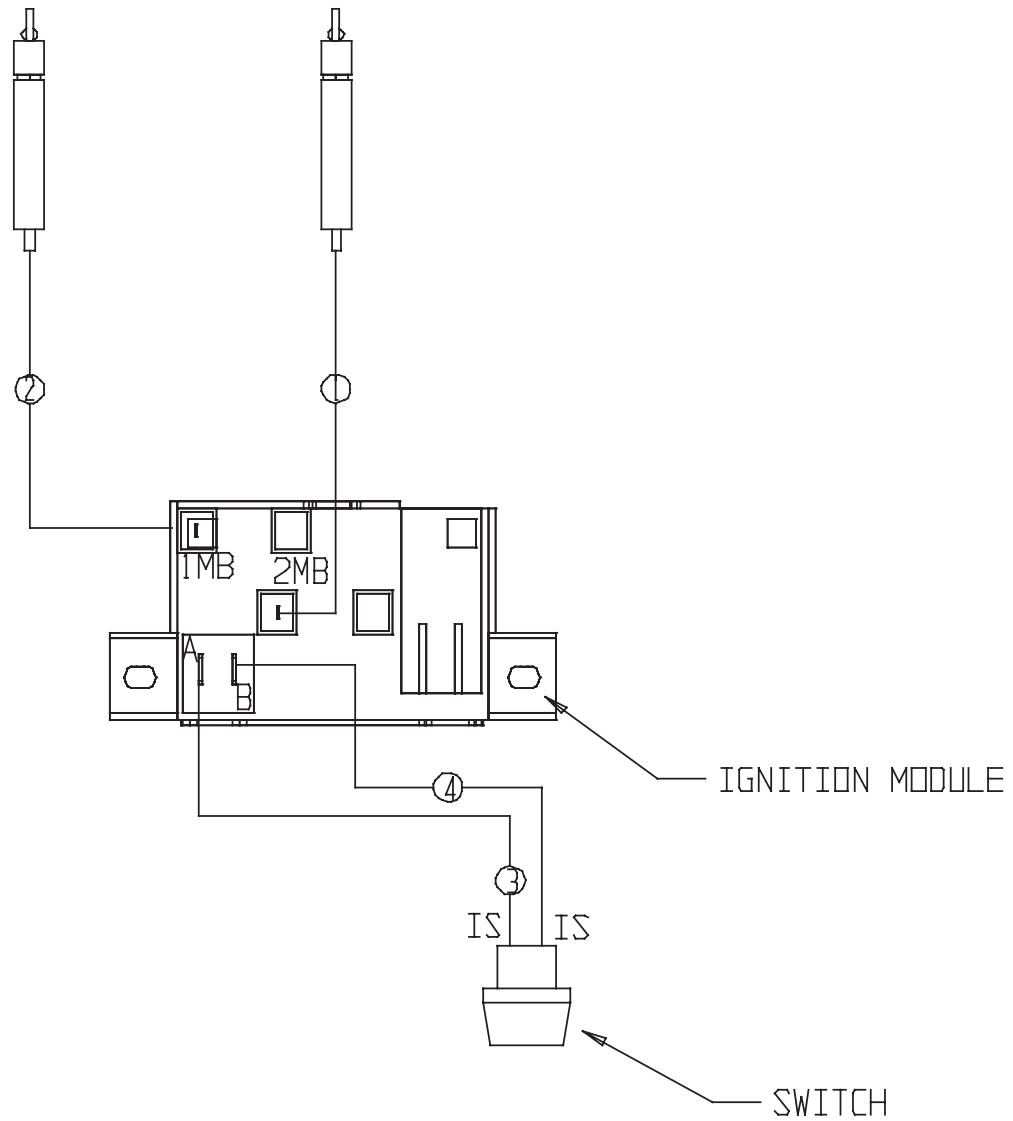

# Wiring Diagram for EDV27-BQR

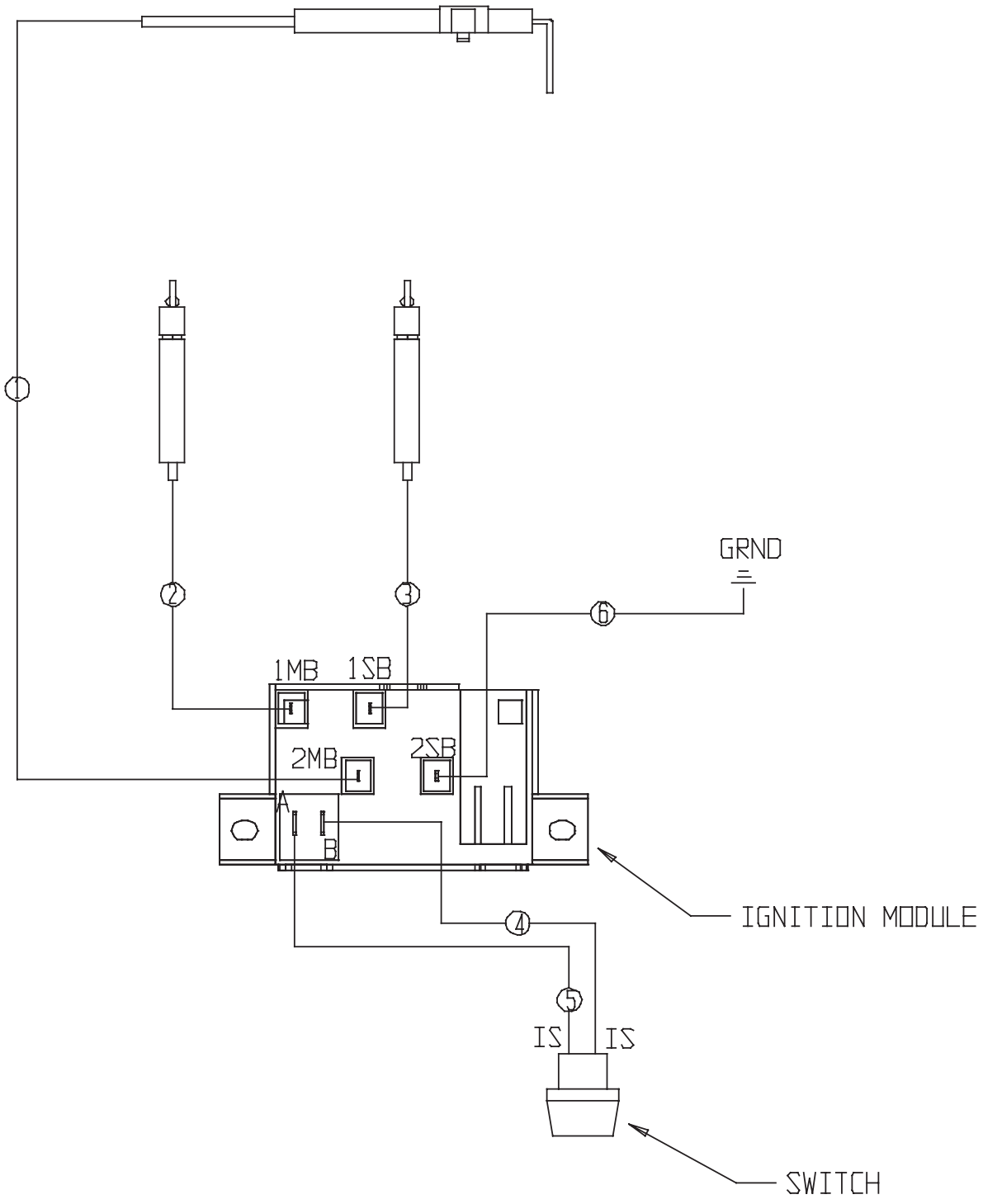

# Wiring Diagram for EDV36-BQA

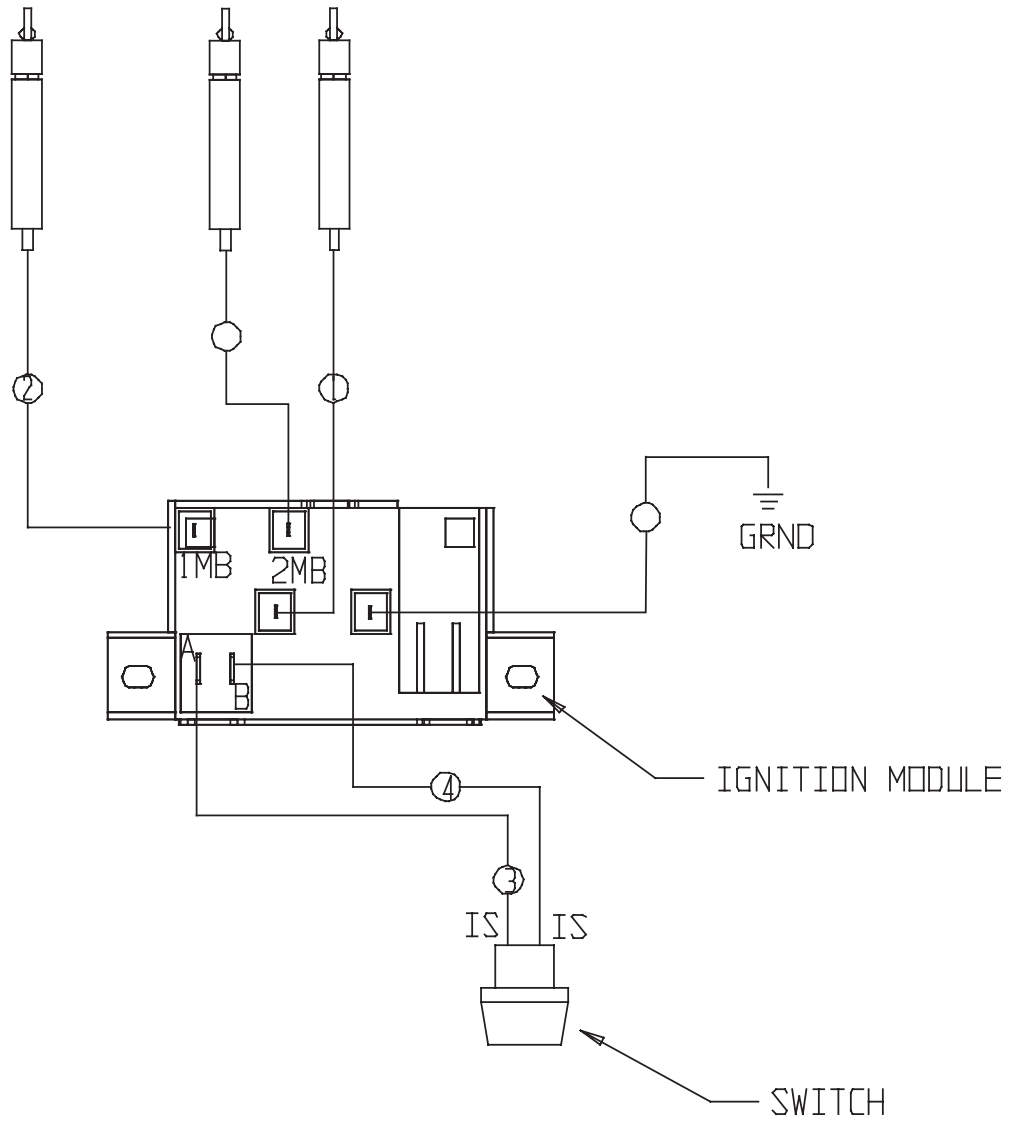

# Wiring Diagram for EDV36-BQAR

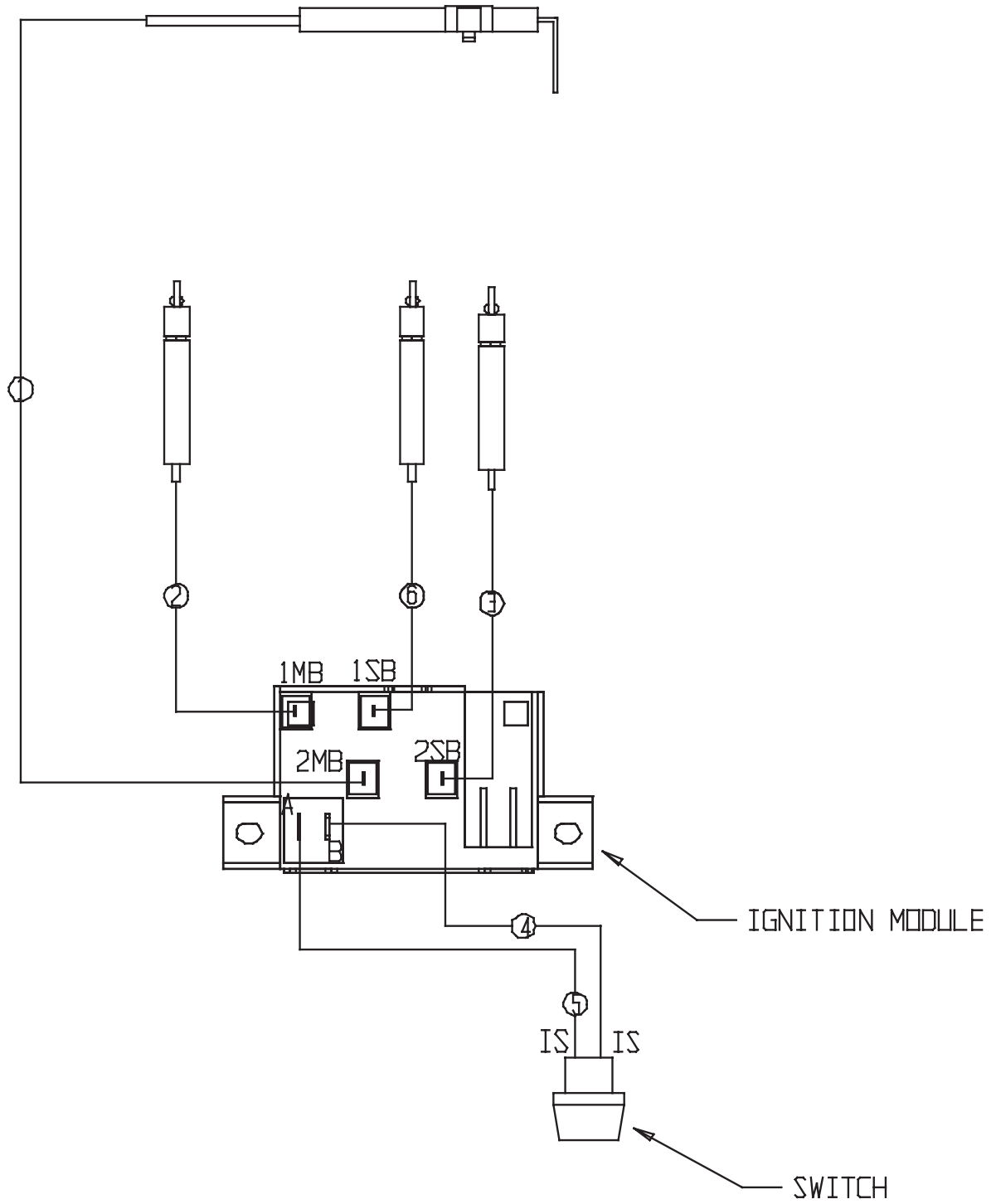

## Service

### HOW TO OBTAIN SERVICE:

For warranty service, contact Customer Service at 877-553-0243.

Before you call, please have the following information ready:

- Model Number
- Serial Number
- Date of installation
- A brief description of the problem

Your satisfaction is of the utmost importance to us. If a problem cannot be resolved to your satisfaction, please call at 877-553-0243.



# Warranty

## LENGTH OF WARRANTY:

**One (1) Year** Full parts and Labor Covers the entire product

**Five (5) Year** comprehensive warranty covering grill radiant assemblies, and drip pans. Should structural deterioration occur to the degree of non-performance, a replacement will be furnished.

**Lifetime Warranty** on all stainless steel components, including stainless steel grill burners and stainless steel grill racks (excluding discoloration or surface corrosion).

## WILL PAY FOR

All repair labor and parts found to be defective due to materials or workmanship for one full year "IN HOME" warranty during the first year of ownership. This does not apply if the unit was subjected to other than normal household use. Service must be provided by Authorized Factory Agent during normal working hours. No charges will be made for repair or replacement at the location of initial installation or factory for parts returned pre-paid, through the dealer and claimed within the warranty period, and found by to be defective.

Replacement will be F.O.B. , and will not be liable for any transportation costs, labor costs, or export duties. This warranty shall not apply, nor can we assume responsibility for damage that might result from failure to follow manufactures instructions or local codes, where the appliance has been tampered with or altered in anyway or which, in our judgement, has been subjected to misuse, negligence, or accident. Implied warranty shall not extend beyond the duration of this written warranty. This warranty is in lieu of all warranties expressed or implied and all other obligations or liability in connection with the sale of this appliance.

## WILL NOT PAY FOR

- Installation or start-up.
- Shipping damage.
- Service by an unauthorized agency.
- Damage or repairs due to service by an unauthorized agency or the use of unauthorized parts.
- Service during other than normal working hours.
- Improper installation, such as improper hook-up, etc.
- Service visits to teach you how to use the appliance; correct the installation; reset circuit breakers or replace home fuses.
- Repairs due to other than normal household use.
- Damage caused from accident, abuse, alteration, misuse, incorrect installation or installation not in accordance with local codes.
- Units installed in non-residential application such as day care centers, bed and breakfast centers, churches, nursing homes, restaurants, hotels, schools, etc.

This warranty applies to appliances used in residential applications; it does not cover their use in commercial situations. This warranty is for products purchased and retained in the 50 states of the U.S.A., the District of Columbia and Canada. This warranty applies even if you should move during the warranty period. Should the appliance be sold by the original purchaser during the warranty period, the new owner continues to be protected until the expiration date of the original purchaser's warranty period. This warranty gives you specific legal rights. You may also have other rights which vary from state to state.

As product improvement is an ongoing process, we reserve the right to change specifications or design without notice.

**BARBEQUE'S GALORE**  
15041 Bake Parkway Suite-A  
Irvine, CA 92618  
Tel: 949-597-2400

Part No. 17519 Rev. B  
Litho in USA 10/2002