

This Owner's Manual is provided and hosted by [Appliance Factory Parts](http://www.ApplianceFactoryParts.com).

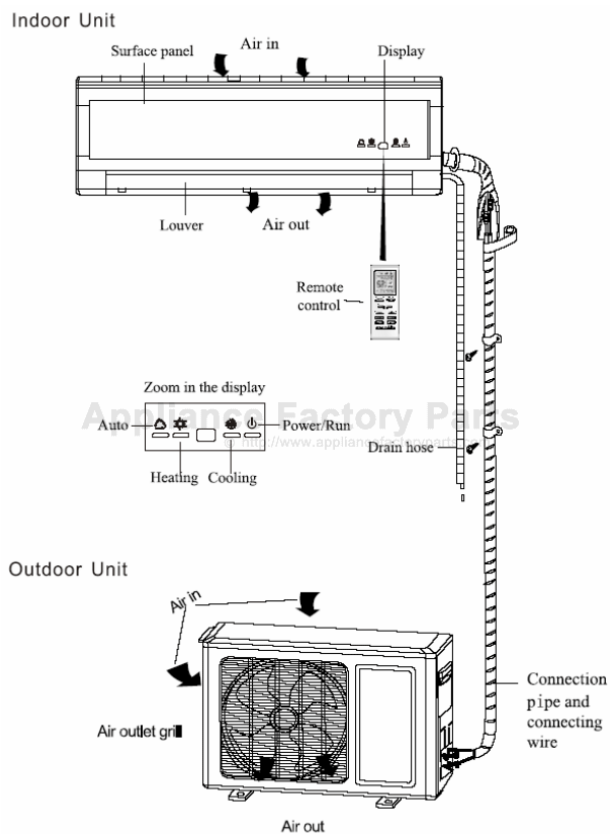

SEA BREEZE 12H43ZGX Owner's Manual

[Shop genuine replacement parts for SEA BREEZE
12H43ZGX](#)



[Find Your SEA BREEZE Air Conditioner Parts - Select From 23 Models](#)

----- Manual continues below -----



INSTALLATION INSTRUCTIONS

MINI-SPLIT HEAT PUMP

FOR MODELS:

12H43ZGX
18H43ZGX

TABLE OF CONTENTS

MODEL NUMBERS.....	2
UNIT PARTS & FEATURES.....	3
INSTALLATION DIMENSION DIAGRAM.....	4
SAFETY WARNINGS.....	5
SELECTION OF INSTALLATION LOCATIONS.....	6
INDOOR UNIT INSTALLATION.....	8
OUTDOOR UNIT INSTALLATION.....	11
TESTING.....	13
PRINCIPLE.....	15
SPECIFICATIONS.....	17
WARRANTY.....	18

TECHNICAL SUPPORT

IF YOU NEED TECHNICAL SUPPORT PLEASE CALL
1-(704)504-8590

SEA BREEZE Installation Kit is recommended.
Catalog number can be located on page 17.

MODEL NUMBERS

Heat Pump

SYSTEM MODEL	Indoor Unit	12H43ZIGX
12H43ZGX	Outdoor Unit	12H43ZOGX

12,000 BTU 208-230 VAC
13 SEER

SYSTEM MODEL	Indoor Unit	18H43ZIGX
18H43ZGX	Outdoor Unit	18H43ZOGX

18,000 BTU 208-230 VAC
13 SEER

UNIT PARTS & FEATURES

Indoor Unit

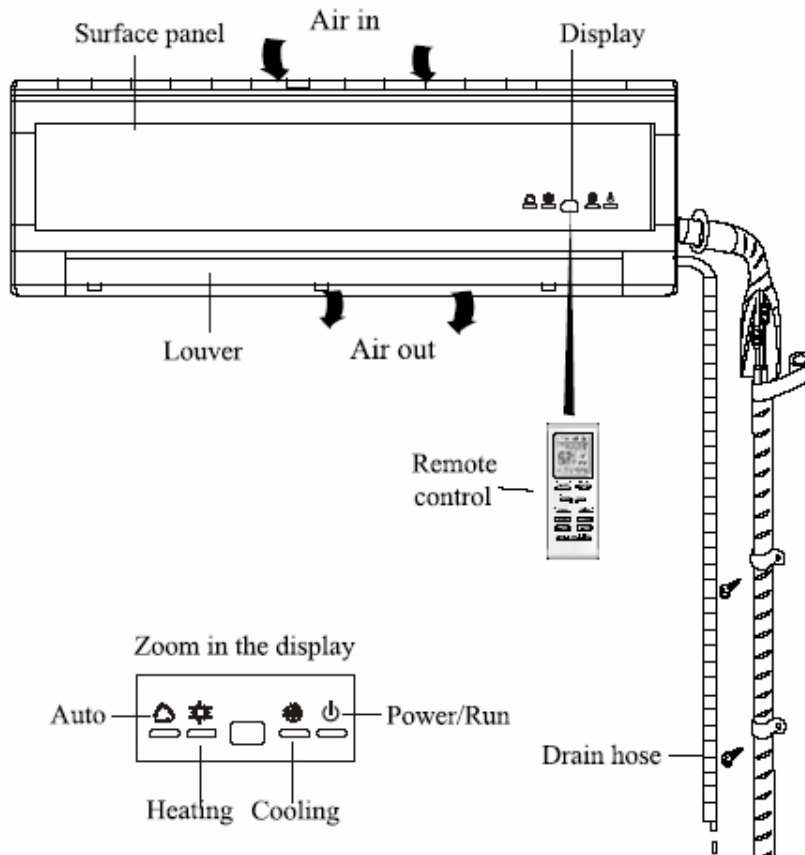

Outdoor Unit

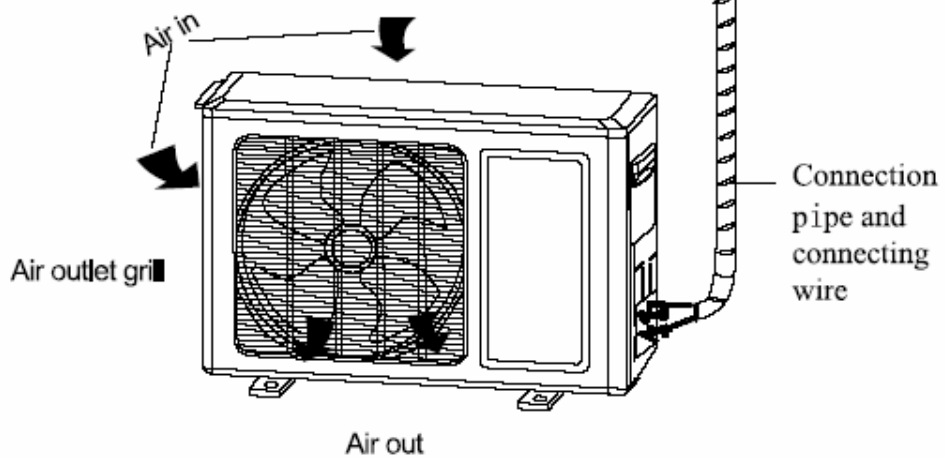

INSTALLATION DIMENSION DIAGRAM

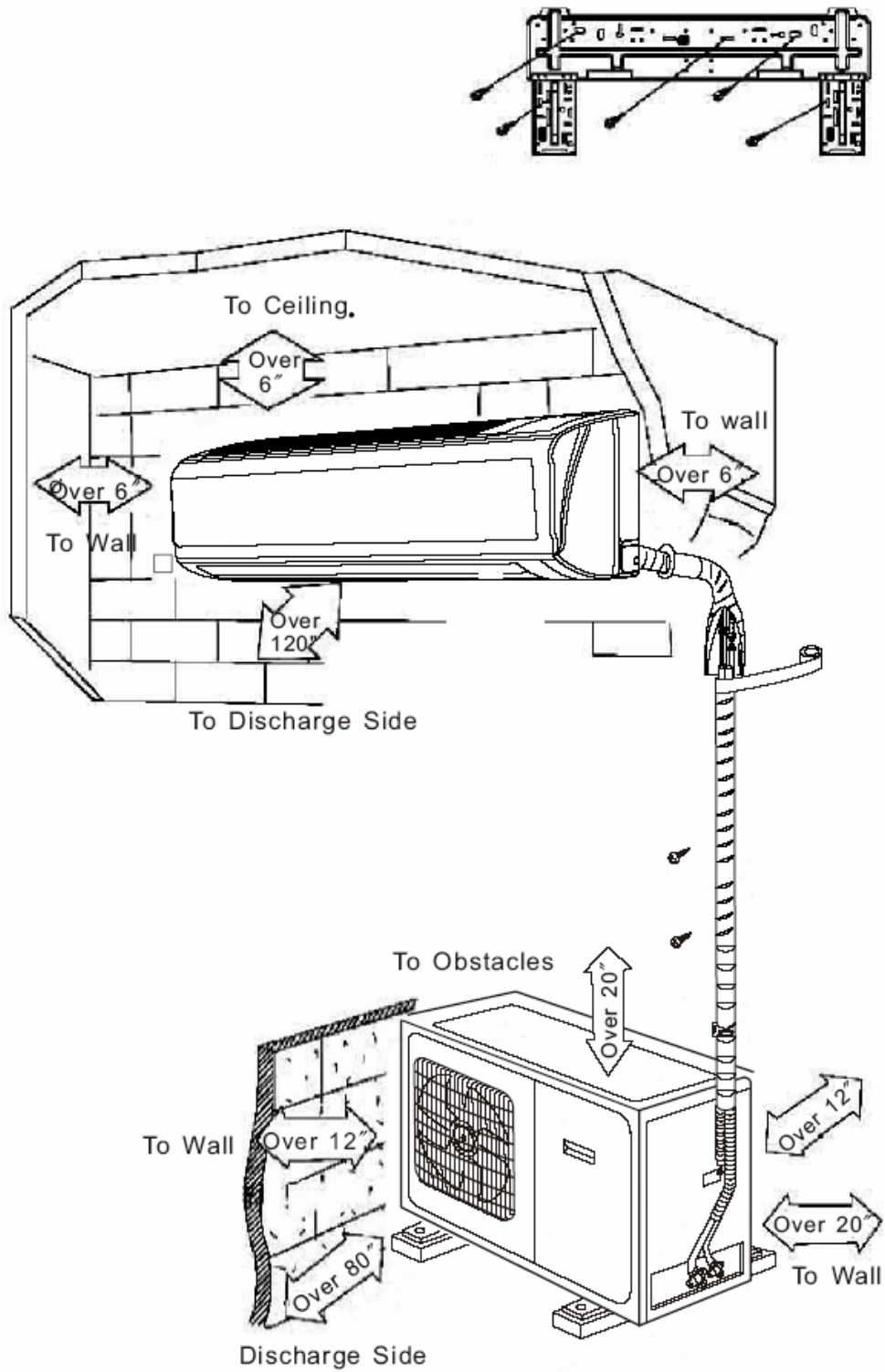

SAFETY WARNINGS

- Use Copper Wires only for Power Supply.
- Risk of electric shock can cause injury or death. Disconnect all electric power supplies before servicing or installation
- Do not use excessive torque on flare nuts during connection of the refrigeration tubes, or service valve on discharge line may be damaged.
- Do not install indoor unit in damp or wet locations.
- Electrical installation must be done by a qualified technician according to the instruction manual and in accordance with local electrical standards.
- Certified Power supply conductors must be used.

SELECT INSTALLATION LOCATION

CAUTION: *The air conditioning unit must be installed by professional technicians.*

BASIC REQUIREMENTS FOR INSTALLATION POSITION

Installation of Either unit in the following locations may cause malfunction.

Locations exposed to:

Machine oil

Flammable or corrosive gasses

High frequency waves (i.e. from radio equipment, medical equipment, etc.)

INDOOR UNIT LOCATION

Intake and outlet should not be obstructed.

The wall the unit is to be mounted on should allow for a clear hole for the condensation drain and the refrigeration lines.

The wall the unit is mounted on should be strong enough to bear the weight and vibration of the unit.

Allow for proper clearances around the unit - see installation dimension diagram.

Location should allow easy access for maintenance and removal of air filter.

Position unit and remote control at least 3 feet from electric appliances such as televisions, radios, etc.

Keep unit and remote out of direct sunlight and/or florescent lighting and away from any excessive heat source, steam, or flammable materials.

OUTDOOR UNIT LOCATION

Allow sufficient ventilation around the unit - see installation dimension diagram.

The air intake and outlet should not be obstructed.

Position unit so that noise and outlet airflow will not inconvenience neighbors.

Position unit on a solid foundation. Location should be able to withstand the full weight and vibration of the unit.

Installation should not be performed in the following locations exposed to: machine oil, flammable or corrosive gases, high - frequency waves (i.e. from radio equipment, medical equipment, etc.)

Installation location should be beyond the reach of children.

SELECT INSTALLATION LOCATION (Cont)

ELECTRICAL SAFETY REQUIREMENTS

The power supply must be of rated voltage via special circuit for air-conditioner. The power supply wire gauge is specified in page 9.
Applicable voltage range: the normal operation range of voltage is 90%~110% of rated voltage.
Do not pull the power cable with excessive force.
System grounding to be completed by a licensed technician, using National Electrical Code procedures and UL materials. In the fixed line there must be an electrical leakage protection switch and an air switch with sufficient capacity. The air switch shall also have the magnetic tripping and thermal tripping functions to achieve protection of both short-circuit and overload.
The minimum clearance between air conditioner and flammable surface is 5 ft.

GROUNDING REQUIREMENT

As air-conditioning unit is of Class I electrical appliance, reliable grounding measures must be taken for it.
The green cable inside the air conditioner is for grounding and shall not be used for other purposes nor can it be cut. Do not tighten with tapping screw; otherwise electric shock will be caused.
The ground resistance shall be in conformity with the requirements of state standard.
The user power supply shall have reliable grounding terminal. It is prohibited to connect the grounding wire to the following items:
Water Supply Pipe
Gas Pipe
Sewage Pipe
Other positions that are considered to be unreliable by professionals.

INDOOR UNIT INSTALLATION

INSTALL THE REAR PANEL-MOUNTING PLATE

Always mount rear panel horizontally.

Hold the rear panel on the wall where you want the unit to be located and ensure that it is level using a plumb line or level. Once leveled, mark the screw locations on the wall.

Fasten the rear panel to the wall at the location marked using the screws supplied with the unit. Insure that the panel has been mounted firmly to withstand the weight of the unit for about 132 lbs, with the weight being evenly distributed by each screw.

INSTALL THE PIPING HOLE

Select the location for the piping hole - either left-positioned or right-positioned (see installation dimension diagram).

Make piping hole in the wall approximately 2.5 inches in diameter at a slight downward slant (this ensures proper drainage).

Insert a piping-hole sleeve in the hole (i.e. PVC pipe) to prevent the connection piping and wiring from being damaged

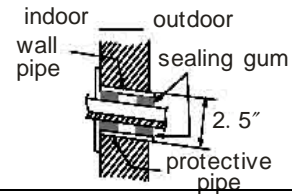

INSTALL DRAINAGE HOSE EXTENSION (OPTIONAL)

Drainage hose extension is included with unit, for use if attached drainage line is not long enough for your application.

Please note that the extension can be installed after existing drainage pipe is fed through wall later in the installation process, if it is determined later that it is necessary.

Do not wrench or bend drainage hose or extension.

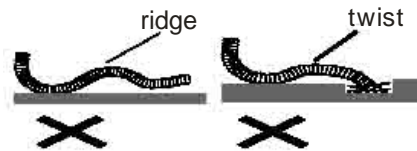

WIRE THE INDOOR UNIT

CAUTION: All electrical wiring must be done by a qualified technician in accordance with local electrical codes.

A separate circuit breaker must be provided.

AC power for the indoor unit is provided by the power cable that runs between the outdoor unit and the indoor unit.

If a disconnect switch is required for the indoor unit, it must be properly rated. Disconnect switch may be installed by breaking the individual wires connected to pins (N1) and (3) of the control cable. See table 1 for recommended value.

INDOOR UNIT INSTALLATION (Cont)

MODEL	INTERCONNECTING WIRE GAUGE	POWER SUPPLY WIRE GAUGE	CIRCUIT BREAKER
12H43ZGX	16 AWG	14 AWG	15 AMP
18H43ZGX	16 AWG	14 AWG	20 AMP

-Table 1-

Terminal board diagram

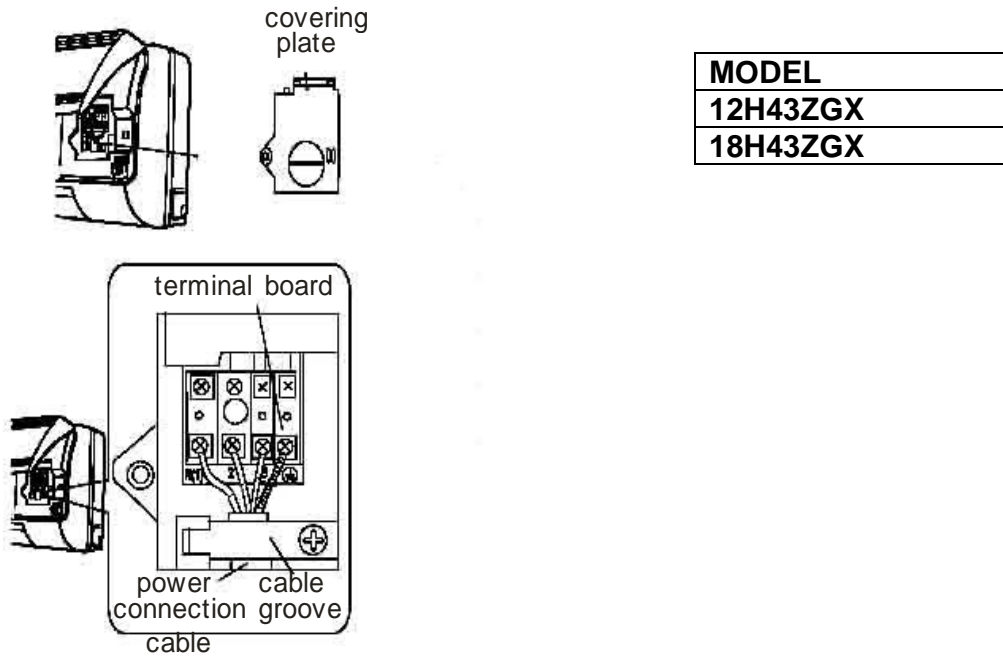

NOTE:

Power connection cable is provided in the installation kit (sold separately). If the cable is not of sufficient length, it will be necessary to purchase cable for this purpose.
Do not splice cable.

INDOOR UNIT INSTALLATION (Cont)

PREPARE REFRIGERATION LINES

Refrigeration lines and wiring can be routed from the indoor unit several different ways using the cut-out access pieces on the back of the unit.

Bend the refrigeration lines carefully to the position needed to align with the drilled piping hole.

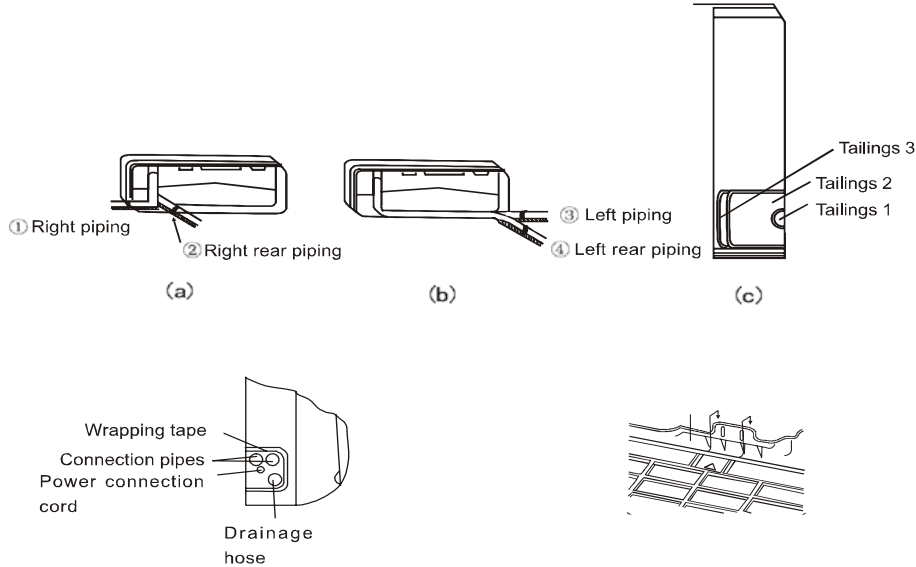

HANG INDOOR UNIT

Bundle the refrigeration lines, drainage hose, and wiring conduit attached to the indoor unit and wrap them securely for enough length to extend through the piping hole to the exterior of the building.

Note: leave remainder unwrapped to allow for remaining step in installation of the outdoor unit and connecting the indoor unit to the outdoor unit.

Carefully push bundled lines through the piping hole.

Hang the unit on the wall by hooking the mounting slots of the unit over the upper tabs of the rear panel.

Check to make sure the: unit is properly secured - it should feel firmly attached to the wall, and you should not be able to slide it to the right or left.

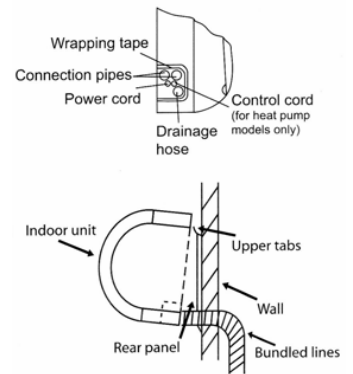

OUTDOOR UNIT INSTALLATION

CONNECT REFRIGERATION LINES

Align the center of the piping flare with the relevant valve.
Use standard A/C practices to attach the connection pipes to the proper pipes of the bundled lines coming through the wall from the indoor unit.

Tighten the flare nut of the connection pipes using a spanner and torque wrench. (see diagram)

Note:

Do not over-tighten flare nuts, or the connection may be damaged.

Unit is charged with enough R410A Refrigerants for a standard designed length. For longer line set lengths additional charge must be WEIGHED in per Table 2.

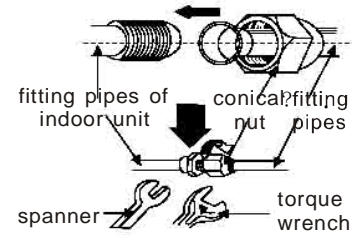

Model	Designed Length ft	Refrigerants Charge oz/ft
12H43ZGX	19	.21
18H43ZGX	26	.26

-Table 2-

INSULATE/BUNDLE REFRIGERATION LINES AND WIRING

Individually insulate all refrigeration lines and condensation drainage hose to ensure that they do not sweat. This will help to maintain the unit at its proper capacities.

Once all lines have been properly insulated, bundle the refrigeration lines with the wiring conduit and wrap securely to complete the run to the outdoor unit.

Note:

The condensation drainage hose should be left free of the bundled lines in order to drain properly.

INSTALL OUTDOOR CONDENSATION DRAINAGE HOSE

When the heat pump unit is heating or defrosting, wastewater forms in the outdoor unit. This can be drained off using the outdoor drain elbow and hose provided.

Insert the drain elbow into the hole on the base plate as shown.

Join the drain hose to the elbow and turn so that the water drains to the desired location.

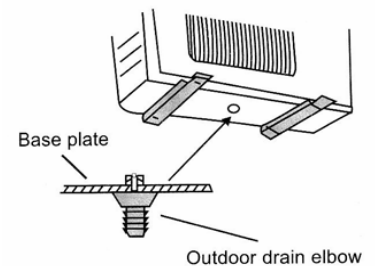

WIRE THE OUTDOOR UNIT

CAUTION:

Wrong wiring connection will cause electrical malfunction.

Do not pull the wire when it is fixed with wire clamp.

OUTDOOR UNIT INSTALLATION (Cont)

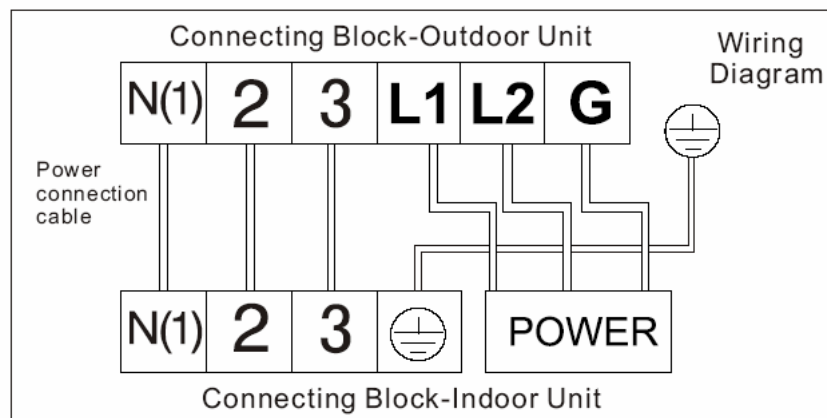
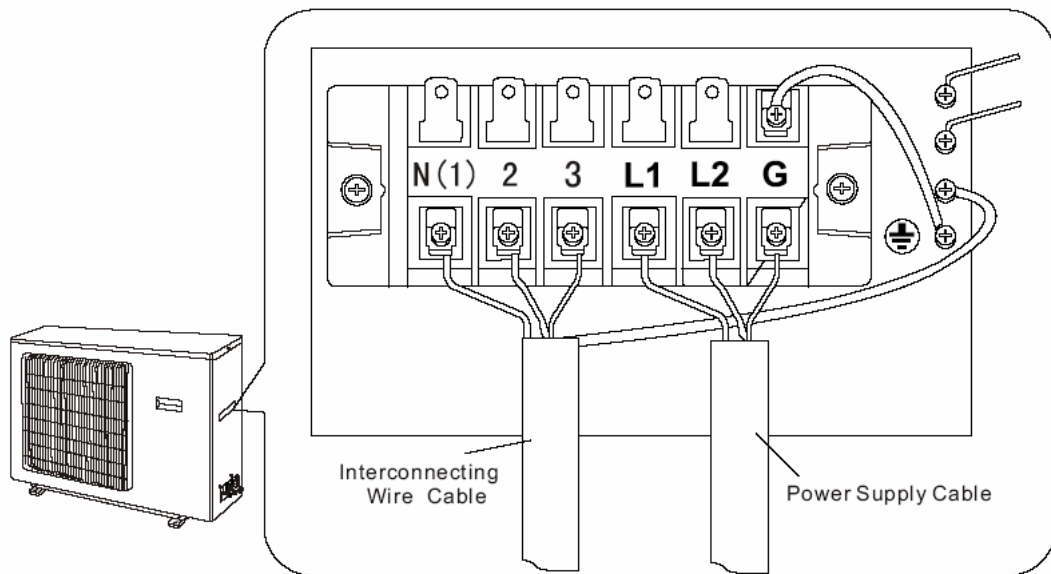

CAUTION: DO NOT CROSS WIRE

TESTING

NOTE:

Installation **MUST** be complete prior to testing.
System **MUST** be tested prior to operation.

LEAKAGE TEST

Use standard A/C practices to properly check refrigeration tubes and connections for any leaks prior to system start up.

AIR PURGING AND PRESSURE TEST

Remove bonnet (cover) of gas valve on outdoor unit.

Charge system with Nitrogen to 100 PSI and check for leaks.

Evacuate Nitrogen.

Connect the gas valves of a vacuum gauge, vacuum pump, and outdoor unit(see diagram). Start the vacuum pump and allow to run for at least 30 minutes at a level of 500 microns or less.

Shut off the vacuum and continue to monitor vacuum gauge for another 15 minutes. The pressure should not rise above 800 microns.

If a vacuum of 500 microns cannot be obtained, or if it rises above 800 microns during the 15-minute monitoring period, pressurize the system with nitrogen and look for leaks. Repair any leaks that are found and repeat the vacuum testing.

Close the valves to the vacuum pump and gauge and disconnect from the outdoor unit.

Tighten bonnet (cover) of gas valve and open gas and liquid valves completely.

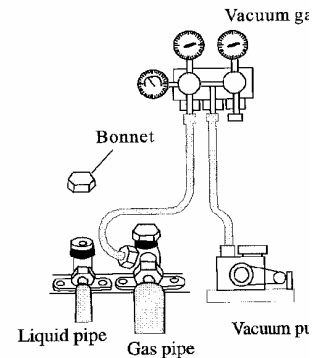

SYSTEM TESTING

Before testing the system, ensure that cut-off valves of the connection pipes are opened and that all debris (such as packing scraps, debris, etc.) are clear from the unit.

Switch on power to the system and press the "ON/OFF" button on the remote control to activate the indoor unit.

Press "MODE" button repeatedly, taking a moment on each setting to ensure that system functions in all modes.

If the remote control is lost, emergency run operation can be initiated by pressing the button in the upper right corner of the indoor unit under the cover panel. (see diagram)

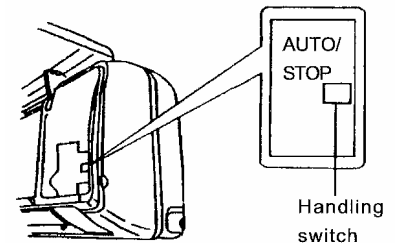

TESTING (Cont)

INSTALLATION VERIFICATION

- Have both units been securely and firmly installed?
- Are all piping connections secure?
- Have the refrigeration lines been sufficiently insulated?
- Have you verified the length of the connection pipes and the refrigerant capacity?
- Have you conducted all leakage and system tests?
- Does the unit drain properly?
- Are all electrical connections in compliance with local standards?
- Has the unit been properly grounded?
- Is the power cord as specified?
- Are all air inlets and outlets free from obstruction?

PRINCIPLE

COOLING MODE

Principle:

The air conditioner absorbs heat from indoor air and transmits it outdoors for discharge, hence to decrease the indoor ambient temperature. The cooling capacity decreases with the rise of outdoor ambient temperature.

Anti-freeze Function:

If the air conditioner is running under low-temperature cooling mode, frost will appear on the surface of indoor heat exchanger. When the temperature of indoor heat exchanger is decreased to 32°F or below, the microcomputer of indoor unit will stop the compressor to protect the complete unit.

HEATING MODE

Principle:

The air conditioner absorbs heat from outdoor air and transmits it indoors for emission, hence to increase the air temperature in the room. The heating capacity decreases with the reduction of the outdoor ambient temperature.

It takes only a short time for this type of hot air circulating system to increase the indoor temperature. Use this air conditioner with other heating equipment if the outdoor temperature is extremely low.

Defrost:

When the outdoor temperature is low but the humidity is high, the heat exchanger of outdoor unit may frost after the air conditioner has run for a period of time. This will decrease the heating effect.

In this case, auto defrost function will be activated and the heating mode will temporarily stop for 8-10 minutes.

Both the indoor fan and outdoor fan will be stopped during auto defrost.

During defrost, the indicator on indoor unit will blink and steam might flow from the indoor unit. This is caused by the defrost mode.

Heating mode will automatically resume upon completion of defrost process.

Anti-Draft Protection:

If the following conditions are present, the control circuitry in the unit will prevent the indoor fan from operating:

1. Heat mode (delay 3 minutes).
2. Auto defrost (delay 3 minutes after defrost cycle has completed).
3. If the outdoor ambient temperature falls below 20 °F, indoor fan will not operate.

PRINCIPLE (Cont)

Air Conditioner is Unable to Run Normally

Protection device might be activated within such temperature range as Table 3, so that the unit might be stopped.

	Heating Mode	Cooling Mode	Dehumidify Mode
Outdoor Temperature	$\geq 75^{\circ} \text{ F}$ or $\leq 20^{\circ} \text{ F}$	$\geq 109^{\circ} \text{ F}$	N/A
Room Temperature	$\geq 80^{\circ} \text{ F}$	$\leq 70^{\circ} \text{ F}$	$\leq 64^{\circ} \text{ F}$

- Table 3 -

NOTE: If the unit operates in cooling or humidify mode for a long period that the relative humidity is higher than 80% (while door and windows open), dew might drop near the air outlet.

MINI-SPLIT SPECIFICATIONS			
Model	12H43ZGX	18H43ZGX	
Function	COOLING/HEATING	COOLING/HEATING	
Rated Voltage	208-230 VAC	208-230 VAC	
Rated Frequency	60Hz	60Hz	
Cooling/Heating Capacity (BTU/h)	12000/13000	18000/20000	
SEER	13	13	
Cooling/Heating Power Input (W)	1150/1250	1720/1750	
Cooling/Heating Rated Input (W)	1100/1200	1350/1800	
Cooling/Heating Rated Current (A)	5.5/6.5	8.56-7.74/8.65-7.83	
Minimum Circuit Ampacity (A)	7	10	
Breaker Size (A)	15	15	
Air Flow Volume (CFM)	325	470	
Dehumidifying Volume (pt/h)	2.7	4.4	
Indoor unit	Model of Indoor Unit	12H43ZIGX	18H43ZIGX
	Fan Motor Speed (r/m) (L/M/H)	1050/1100/1250	1250/1300/1350
	Output of Fan Motor (w)	20	21
	Input of Heater (w)	None	None
	Fan Motor Capacitor (uF)	1	1
	Fan Motor RLA(A)	0.152	0.28
	Fan Type-Piece	Cross flow fan-1	Cross flow fan-1
	Diameter-Length (in)	3.6-24.3	3.8-31.4
	Evaporator	Aluminum fin-copper tube	Aluminum fin-copper tube
	Pipe Diameter (in)	0.275	0.275
	Row-Fin Gap(in)	2-0.055	2-0.063
	Coil length (L) x height (H) x coil width (L) (in)	26.8x12.8x1.5	30.1x13.4x1
	Swing Motor Model	MP28EA	MP24GA
	Output of Swing Motor (W)	2	2
	Fuse (A)	PCB3.15A Transformer 0.2A	PCB3.15A Transformer 0.2A
	Sound Pressure Level dB (A)(L/M/H)	38/39/43	40/43/46
	Sound Power Level dB (A)	48/49/53	50/53/56
	Dimension (W/D/H)(approx in)	33x9x11	40x9x12
	Dimension of Package (W/D/H)(approx in)	34x12x15	42x13x15
	Net Weight /Gross Weight (lb)	24/33	31/41
Outdoor unit	Model of Outdoor Unit	12H43ZOGX	18H43ZOGX
	Compressor Model	Sanyo C-6RZ092H1AB	Hitachi EU1013DD
	Compressor Type	Rotary	Scroll
	L.R.A. (A)	33	27
	Compressor RLA(A)	5	6.54
	Compressor Power Input(W)	628	1266
	Overload Protector	Yes	Yes
	Throttling Method	Capillary throttling	Capillary throttling
	Starting Method	Transducer starting	Transducer starting
	Outdoor Operating Range	23°F to 109°F	23°F to 109°F
	Condenser	Aluminum fin-copper tube	Aluminum fin-copper tube
	Pipe Diameter (in)	3/8	3/8
	Rows-Fin Gap(in)	2-0.055	2-0.059
	Coil length (L) x height (H) x coil width (L) (in)	25.4x20x1.7	28.8x26x1.7
	Fan Motor Speed (rpm)	830	780/620
	Output of Fan Motor (W)	30	60
	Fan Motor RLA(A)	0.3	0.65
	Fan Motor Capacitor (uF)	2.5	3
	Air Flow Volume of Outdoor Unit (CFM)	1200	1600
	Fan Type-Piece	Axial fan -1	Axial fan -1
	Fan Diameter (in)	15.75	15.75
	Defrosting Method	Auto defrost	Auto defrost
	Climate Type	T1	T1
	Isolation	I	I
	Moisture Protection	IP24	IP24
	Design Pressure High (Psig)	500	450
	Design Pressure Low (Psig)	450	400
	Sound Pressure Level dB (A)	54	≤56
	Sound Power Level dB (A)	64	≤66
	Dimension (W/D/H)(approx in)	33x13x21	37x13x27
Dimension of Package (W/D/H)(approx in)	35x14x24	43x18x30	
Net Weight /Gross Weight (lb)	99/110	130/141	
Refrigerant Charge (lb)	R410A/2.8	R410A/3.85	
Extra Refrigerant Charge above design length (oz/ft)	0.21	0.26	
Connection Pipe	Design Length (ft)	19	26
	Outer Diameter Liquid Pipe (in)	1/4	3/8
	Outer Diameter Gas Pipe (in)	1/2	5/8
	Max Distance Height (ft)	20	31
	Max Distance Length (ft)	39	59
	Installation Kit Catalog Number	LS1412GHSB	LS3858GSB

WARRANTY

SEA BREEZE AIR warrants the accompanying split air conditioner or heat pump system to be free of defects in material and workmanship for the applications specified in the operation manual and installation manual for a period of one (1) year on parts and five (5) years on compressor, valid from the date of original retail purchase in the United States or Canada. Labor is not covered under warranty.

If the unit exhibits a defect in normal use and is determined to be within the warranty period, **SEA BREEZE AIR** will, at its option, either repair or replace the unit free of charge within a reasonable time after the unit is returned.

This warranty **DOES NOT** cover:

- Damage, accidental or otherwise, to the unit while in possession of the consumer that is not a result of a defect in material in workmanship.
- Damage caused by consumer misuse, tampering, or failure to follow all care and maintenance instructions in the manuals.
- Damage to the finish of the case or other parts caused by water.
- Damage caused by repairs or alterations to the unit by anyone other than a qualified technician.
- Filter.
- Freight and Insurance cost for the warranty service.

Warranty Activation Card must be completed and sent in to activate the warranty for the accompanying unit.