

This Owner's Manual is provided and hosted by [Appliance Factory Parts](#).



COOLERATOR CAW06D1A1 Owner's Manual

[Shop genuine replacement parts for COOLERATOR
CAW06D1A1](#)

[Find Your COOLERATOR Air Conditioner Parts - Select From 61 Models](#)

----- Manual continues below -----

Installation & Operation Guide

5,000 to 12,000 BTUH
COOLING ONLY

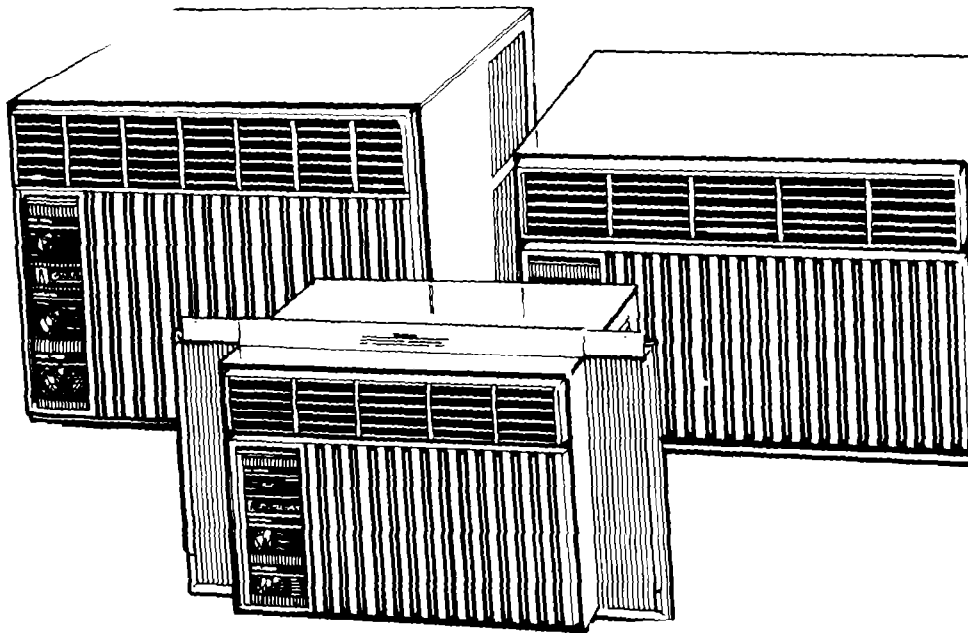

IMPORTANT...

Please read this use and care guide before installing or using your air conditioner. It tells you how to install and operate it, and gives important electrical information. Save it for future use in case you may have a question or move the air conditioner.

Copy your Model and Serial Numbers here...

When you need service or call with a question, have this information ready:

- 1. Complete Model and Serial Numbers.** To find Model and Serial Numbers remove the front panel (see page 16). The numbers are located either on a **plate** attached to the lower front of the unit or on a **label** attached to the evaporator coil cover near the top of the unit.

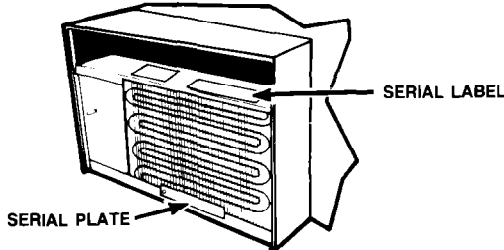

- 2. Purchase date from sales slip.** Copy this information in the spaces below. Keep this book, your warranty and sales slip together in a handy place.

Model Number _____
 Serial Number _____
 Purchase Date _____
 Service Company and Telephone Number _____



CAUTION:
 Handle the air conditioner with care. Watch out for the sharp metal fins on the front and rear coils.

BEFORE YOU USE YOUR AIR CONDITIONER

It is your responsibility to make sure that your air conditioner:

- Has been properly installed.
- Is the right size for the area you want to cool.
- Is properly connected to electricity.
- Is properly electrically grounded.
- Is properly used only for the job it was intended to do.
- Is not used by children or anyone not able to operate it properly.
- Is properly maintained.
- Also, remove energy label and buy guide. Use damp cloth to take off any glue residue. Do not use a sharp instrument or any harsh or abrasive cleaners.

Energy Saving Tips

- Improve home insulation (seal doors, windows, and close fireplace flue).
- Close blinds or drapes on sunny side of house; add window awnings.
- Keep air filter clean. Don't block air flow with drapes or furniture.
- Ventilate attic (high temperature levels add to normal cooling load).
- Try not to use heat producing appliances during the hottest part of the day. Turn lights, radios, televisions, and other appliances off when not needed.
- Keep heat registers and cool air returns closed or blocked off so cooled air won't escape.
- Use a vent fan in areas where cooking, laundry, or bathing is done to pull out extra heat and moisture near its source.

Contents

	page		page
Before You Use Your Air Conditioner	2	Cleaning and Caring for Your Air Conditioner	16
Energy Tips	2	Cooling Load Guide	18
Electrical Requirements	3	Self-Service Checklist	19
Installation Instructions	6	Service Information	19
How to Start and Use Your Air Conditioner	14		

© 1986 Whirlpool Corporation

Electrical Requirements For Your Air Conditioner



ELECTRICAL REQUIREMENTS

BELOW ARE ELECTRICAL PLUG VARIATIONS. CHOOSE THE ONE WHICH MATCHES THE AMPERE RATING OF YOUR UNIT. THE NUMBER OF AMPERES IS PRINTED ON THE SERIAL PLATE, ATTACHED TO THE FRONT OF THE UNIT, BEHIND THE FRONT PANEL (SEE PAGE 2).

For 115 volt models with serial plate amperes up through 7.5

OBSERVE ALL LOCAL GOVERNING CODES AND ORDINANCES

Do not, under any circumstances, remove the power supply cord ground prong.

RECEPTACLE WIRING

RECEPTACLE WIRING should be at least as large as 14 gauge. Use copper wire only. It is the personal responsibility and obligation of the customer to provide proper and adequate receptacle wiring installed by a qualified electrician. OBSERVE NATIONAL ELECTRICAL CODE AND ALL LOCAL GOVERNING CODES AND ORDINANCES.

Electrical Requirements

A 115 volt (103.5 min., 126.5 max.) 60 hertz AC only, 15 ampere fused electrical supply is required (time delay fuse or time delay circuit breaker required). See Figure 1 on page 4. *It is recommended that a separate circuit, serving only this appliance, be provided. Do not use an extension cord.*

Electrical Connection

Electrical Ground is Required on this Appliance

RECOMMENDED GROUNDING METHOD

For your personal safety, this appliance must be grounded. This appliance is equipped with a power supply cord having a 3-prong grounding plug. To minimize possible shock hazard, the cord must be plugged into a mating 3-prong grounding type wall receptacle, grounded in accordance with the National Electrical Code and local codes and ordinances. If a mating wall receptacle is not available, it is the personal responsibility and obligation of the customer to have a properly grounded 3-prong wall receptacle installed by a qualified electrician. See Figure 1 on page 4.

PLUG TYPE	SEE ELECTRICAL REQUIREMENTS
	<p>For 115 volt models with serial plate amperes up through 7.5</p>
	<p>For 115 volt models with serial plate amperes of 7.6 through 12.0</p>
	<p>For 230 volt and 230/208 volt models with serial plate amperes up through 12.0</p>

Figure 1

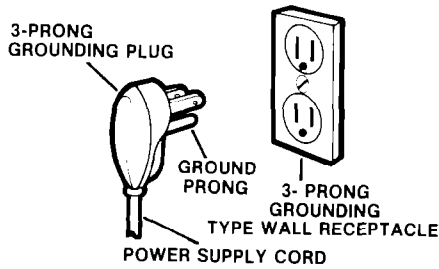

ALTERNATE GROUNDING METHOD

If changing and properly grounding the wall receptacle is impossible and where local codes permit (consult your electrical inspector), a temporary adapter may be plugged into the existing 2-prong wall receptacle to mate with the 3-prong power supply cord. See Figure 2. **THIS, HOWEVER, IS NOT RECOMMENDED.**

If this is done, you must connect the grounded eyelet on the adapter to the wall receptacle cover plate screw and from this same screw, you must connect a separate copper ground wire (#14 minimum) to a grounded cold water pipe.* See Figure 2. Do not ground to a gas supply pipe. Do not connect to electrical supply until appliance is permanently grounded.

Figure 2

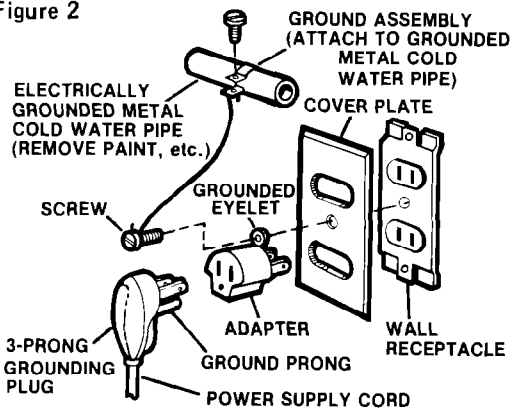

*Cold water pipe must have metal continuity to electrical ground and not be interrupted by plastic, rubber or other electrically insulating connectors (including water meter or pump) without adding a jumper wire at these connections.

B ELECTRICAL REQUIREMENTS

For 115 volt models with serial plate amperes of 7.6 through 12.0

OBSERVE ALL LOCAL GOVERNING CODES AND ORDINANCES

Do not, under any circumstances, remove the power supply cord ground prong.

RECEPTACLE WIRING

RECEPTACLE WIRING should be at least as large as 14 gauge. Use copper wire only. It is the personal responsibility and obligation of the customer to provide proper and adequate receptacle wiring installed by a qualified electrician. OBSERVE NATIONAL ELECTRICAL CODE AND ALL LOCAL GOVERNING CODES AND ORDINANCES.

Electrical Requirements

A 115 volt (103.5 min., 126.5 max.) 60 hertz AC only, 15 ampere fused electrical supply is required (time delay fuse or time delay circuit breaker required). See Figure 3. *It is required that a separate circuit, serving only this appliance, be provided. Do not use an extension cord.*

Electrical Connection

Electrical Ground is Required on this Appliance
RECOMMENDED GROUNDING METHOD

For your personal safety, this appliance must be grounded. This appliance is equipped with a power supply cord having a 3-prong grounding plug. To minimize possible shock hazard, the cord must be plugged into a mating 3-prong grounding type wall receptacle, grounded in accordance with the National Electrical Code and local codes and ordinances. If a mating wall receptacle is not available, it is the personal responsibility and obligation of the customer to have a properly grounded 3-prong wall receptacle installed by a qualified electrician. See Figure 3.

Figure 3

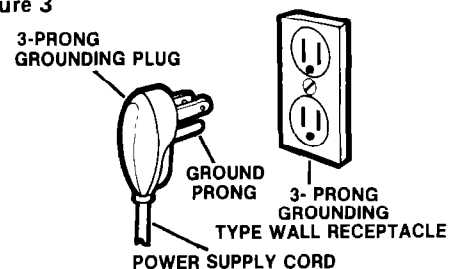

ALTERNATE GROUNDING METHOD

If changing and properly grounding the wall receptacle is impossible and where local codes permit (consult your electrical inspector), a temporary adapter may be plugged into the existing 2-prong wall receptacle to mate with the 3-prong power supply cord. See Figure 4. THIS, HOWEVER, IS NOT RECOMMENDED.

If this is done, you must connect the grounded eyelet on the adapter to the wall receptacle cover plate screw and from this same screw, you must connect a separate copper ground wire (#14 minimum) to a grounded cold water pipe.* See Figure 4. Do not ground to a gas supply pipe. Do not connect to electrical supply until appliance is permanently grounded.

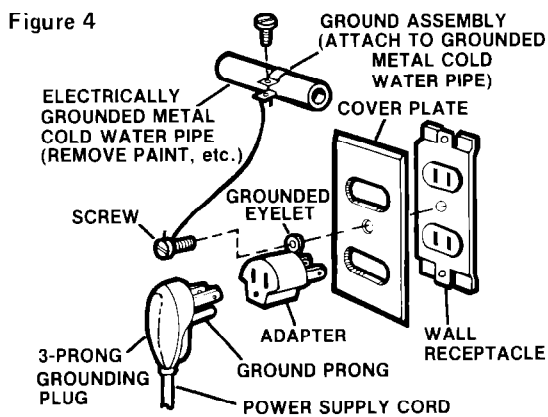

*Cold water pipe must have metal continuity to electrical ground and not be interrupted by plastic, rubber or other electrically insulating connectors (including water meter or pump) without adding a jumper wire at these connections.

C ELECTRICAL REQUIREMENTS

For 230 and 230/208 volt models with serial plate amperes up through 12.0

Refer to Chart C for specific wiring and receptacle information to be used.

OBSERVE ALL LOCAL GOVERNING CODES AND ORDINANCES

Do not, under any circumstances, remove the power supply cord ground prong.

ELECTRICAL GROUND IS REQUIRED ON THIS APPLIANCE.

A three-wire, single-phase 60 hertz AC only electrical supply is required.

A separate electrical supply is required on a separately fused circuit. Do not fuse ground-neutral.

See Chart C for receptacle voltage requirements, proper fuse size, wire size and wiring connections which must conform with rating of the appliance. **Do not use an extension cord.**

Chart-C

PLUG AND RECEPTACLE DATA	RECEPTACLE VOLTAGE (60 HERTZ AC IN ALL INSTANCES)	SERIAL PLATE AMPERES
	MODEL WITH SERIAL PLATE OF 230 VOLTS (207 MIN, 253 MAX.)	up through 12.0
	MODEL WITH SERIAL PLATE OF 230/208 VOLTS (197.6 MIN, 253 MAX.)	
	USE TIME-DELAY FUSE OR TIME DELAY CIRCUIT BREAKER RATING IN AMPS	TYPE OF BRANCH CIRCUIT
	MINIMUM RECEPTACLE WIRE SIZE SEE BELOW	
	14 GAUGE USE COPPER WIRE ONLY	SINGLE OUTLET ONLY

RECEPTACLE WIRING

RECEPTACLE WIRING should be at least as large as size shown on electrical Chart C. Use copper wire only. It is the personal responsibility and obligation of the customer to provide proper and adequate receptacle wiring installed by a qualified electrician. OBSERVE NATIONAL ELECTRICAL CODE AND ALL LOCAL GOVERNING CODES AND ORDINANCES.

RECOMMENDED GROUNDING METHOD

For your personal safety, this appliance must be grounded. This appliance is equipped with a power supply cord having a 3-prong grounding plug. To minimize possible shock hazard, the cord must be plugged into a mating 3-prong grounding type wall receptacle, grounded in accordance with the National Electrical Code and local codes and ordinances. If a mating wall receptacle is not available, it is the personal responsibility and obligation of the customer to have a properly grounded 3-prong wall receptacle installed by a qualified electrician.

INSTALLATION INSTRUCTIONS for Your Air Conditioner

Unpack the accessory parts that came with your air conditioner to determine which window installation instruction you should follow.

If you have these parts, follow:
INSTRUCTION 1
(below)

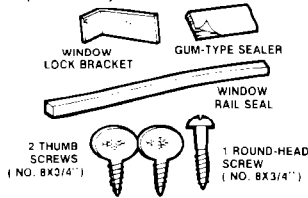

If you have these parts, follow:
INSTRUCTION 2
(on page 8).

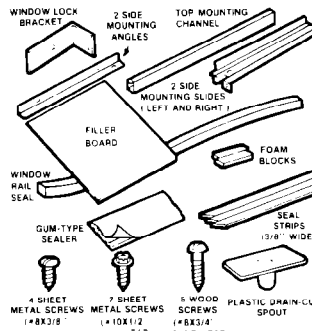

— OR —
For through-the-wall installation, follow:
INSTRUCTION 3
(on page 11).

This installation method for slid-out chassis model only.

1 Installation Instructions

- To help avoid any installation problems and to help assure trouble-free performance of your new air conditioner, read these installation instructions, as well as the operating instructions and electrical requirements and all other product literature before installing your unit.
- Because this air conditioner weighs from approximately 75 to 125 pounds, it is recommended that you have somebody help you install your new unit and that you both use proper lifting techniques to avoid personal injury.
- Inspect the condition of the window where the air conditioner will be installed. Be sure it will support the weight of the unit.

CAUTION:

- Be sure air conditioner does not fall out of window during installation.
- Handle the air conditioner with care. Watch out for the sharp metal fins on the front and rear coils.
- Do not use the collected water for drinking purposes. It is not sanitary.



- Unpack accessory parts (see Figure 5) before installing your air conditioner. A normal installation can be made with a screwdriver, small level, pocket knife, tape measure and a drill with 3/32" drill bit.

Figure 5

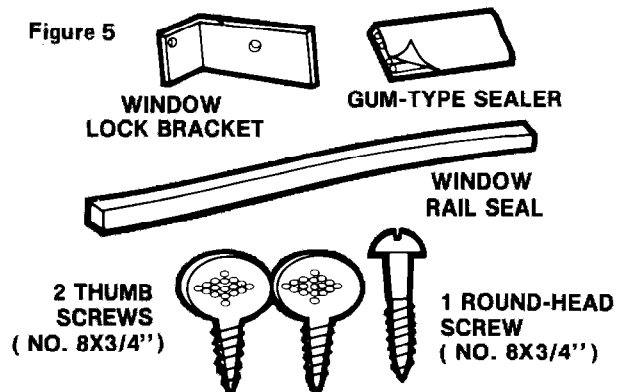

- Pick the right window. First, decide what room(s) you want to cool. Then choose a window that will allow the air-conditioned air to flow freely and directly into the room(s) you want cooled. Remember, it's difficult to move air around corners. Choose a window that's also near an electrical outlet. (Refer to the ELECTRICAL REQUIREMENT pages for type of receptacle and wiring needed.) **Do not use an extension cord.** The window in which you place your air conditioner should have an opening of at least 25 inches in width and at least 16 inches in height (see Figure 6). Standard installation parts are supplied for double-hung sash windows up to 38 inches in width.

Figure 6

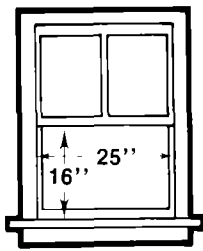
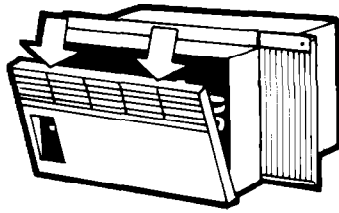

Figure 7



3. Remove front panel by pushing top down and pulling toward you (see Figure 7). This protects the plastic front from damage and makes the air conditioner easier to handle during installation.

 DO NOT BLOCK AIR ENTRY INTO THE SIDE LOUVERS OF THE CABINET.

Figure 8



4. Center air conditioner in window. Rear of unit must be raised slightly to position lower rail of air conditioner behind and up against back side of window sill (see Figure 8). CAUTION: BE SURE UNIT DOES NOT FALL OUT OF WINDOW.) Lower the window sash firmly behind the top mounting channel.

Figure 9

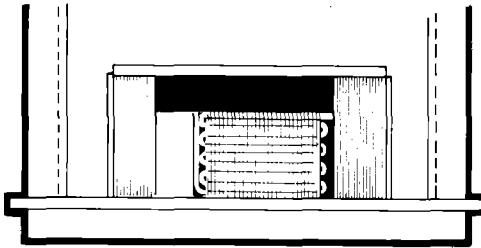
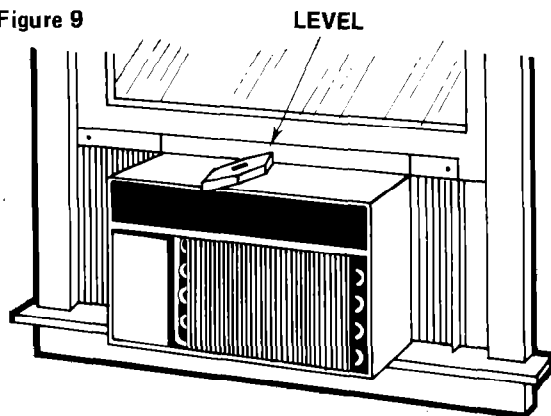

5. Leveling air conditioner is not required in a normal installation. The proper slope is designed into the product. However, be sure you have approximately a one-half bubble ($\frac{1}{2}$ ") downward tilt to the outside for proper water drainage (see Figure 9). If necessary, reposition or shim cabinet to provide the proper tilt or side-to-side leveling

Figure 10

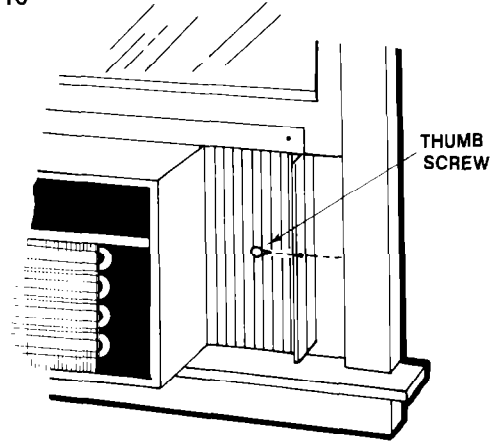

6. Pull out sliding curtains while holding air conditioner in window. Extend curtains on both sides until they engage window channels. Pulling slightly inward allows curtains to slide easily. Mark and make $\frac{3}{32}$ " pilot holes before installing thumb screws in side handles of curtains (see Figure 10). Or, if space is a problem, use holes in top flanges of curtains. (CAUTION: BE SURE UNIT DOES NOT FALL OUT OF WINDOW.)

Figure 11

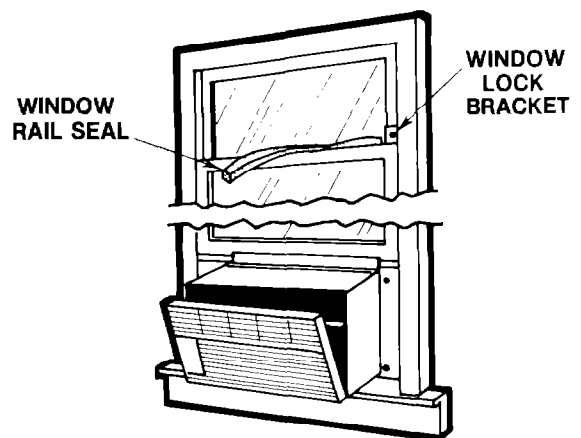

7. **Install window seal and window lock bracket.** Press foam window seal into place and cut to proper length (see Figure 11). Mark and make a 3/32" pilot hole, then install lock bracket using roundhead screw. (CAUTION: KEEP WINDOW LOCK BRACKET INSTALLED AT ALL TIMES TO BE SURE UNIT DOES NOT FALL OUT OF WINDOW. REMOVE ONLY WHEN YOU WISH TO REMOVE AIR CONDITIONER FROM WINDOW.) Seal small openings around installation with gum-type sealer.

8. **Attach front panel** by placing bottom edge on clips and pushing top down, then in and up.

2 Installation Instructions

- To help avoid any installation problems and to help assure trouble-free performance of your new air conditioner, read these installation instructions, as well as your operating instructions and electrical requirements *before* installing your unit.
- Because this air conditioner weighs from approximately 125 to 200 pounds, it is recommended that you have somebody help you install your new unit and that you both use proper lifting techniques to avoid personal injury.
- Inspect the condition of the window where the air conditioner will be installed. Be sure it will support the weight of the unit.

CAUTION:

- Be sure air conditioner does not fall out of window during installation.
- Handle the air conditioner with care. Watch out for the sharp metal fins on the front and rear coils.
- Do not use the collected water for drinking purposes. It is not sanitary.

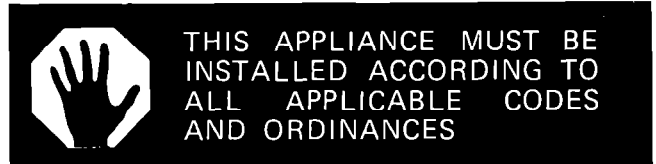

1. **Unpack accessory parts** (see Figure 12) before installing your air conditioner. A normal installation can be made with a screwdriver, saw, small level, pocket knife, tape measure and drill with 3/32" drill bit.

Figure 12

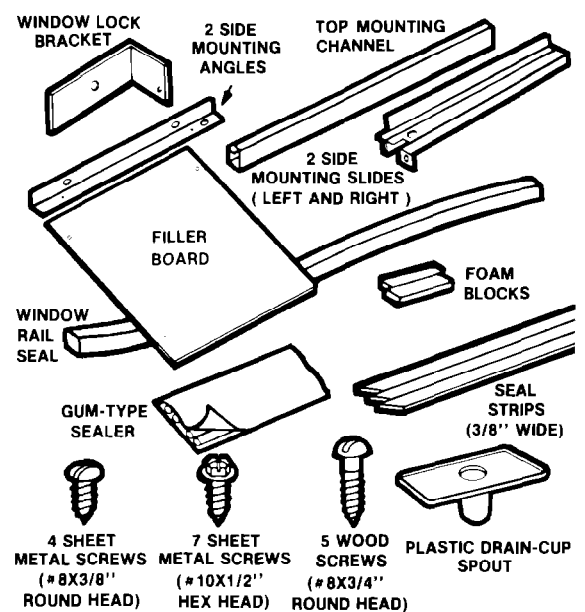

2. **Pick the right window.** First, decide what room(s) you want to cool. Then choose a window that will allow the air-conditioned air to flow freely and directly into the room(s) you want cooled. Remember, it's difficult to move air around corners. Choose a window that's also near an electrical outlet. (Refer to ELECTRICAL REQUIREMENTS for receptacle and wiring needed.) **Do not use an extension cord.** The window in which you place your air conditioner should have an opening of at least 26 inches in width and at least 18 inches in height (see Figure 13). Standard installation parts are supplied for double-hung windows up to 40 inches in width. For a wide installation up to 54 inches, a special wide-window kit is available as a parts item.

Figure 13

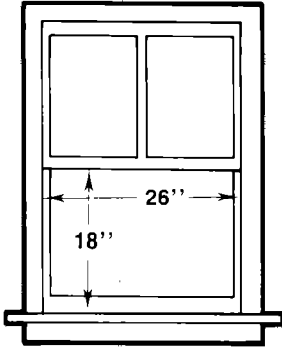

3. Remove front panel by pushing top down and pulling toward you (see Figure 14). This protects the panel from damage and makes the air conditioner easier to handle during installation.

Figure 14

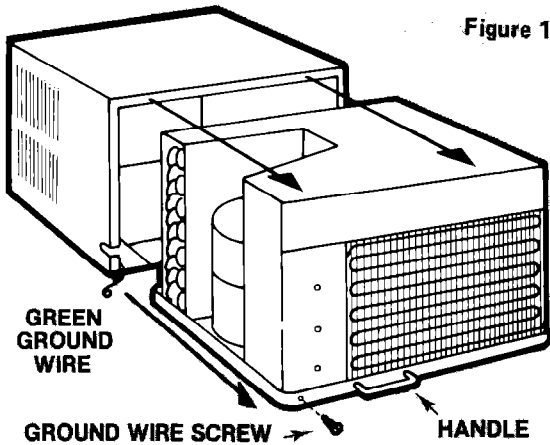
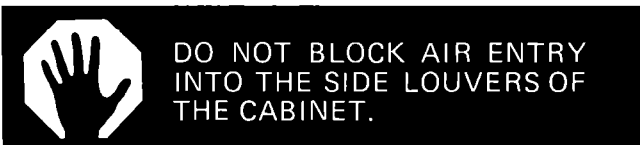
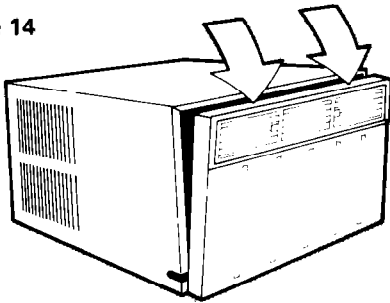

Figure 15

4. Slide unit out of cabinet. First, disconnect the green ground wire at the left-front corner of base of unit by removing retaining screw (save screw for reuse later). Now slide unit out of cabinet by pulling out on handle on bottom (see Figure 15).
5. Attach seal strips to cabinet. Place 3/8" wide self-adhering seal strip on window side of

bottom flange. Now, starting at the lower corner of the cabinet, apply seal strips over the center line of the pre-drilled holes for one of the side mounting angles, over the center line of pre-drilled holes for the top mounting channel, and over the center line of pre-drilled holes for the other side mounting angle. (See Figure 16.)

Figure 16

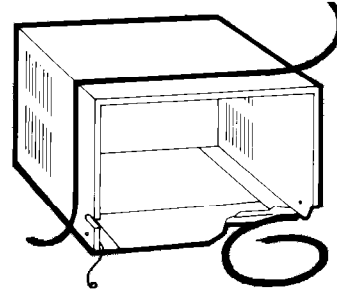
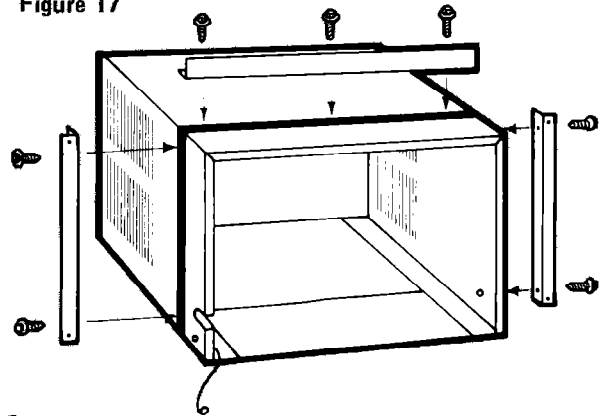
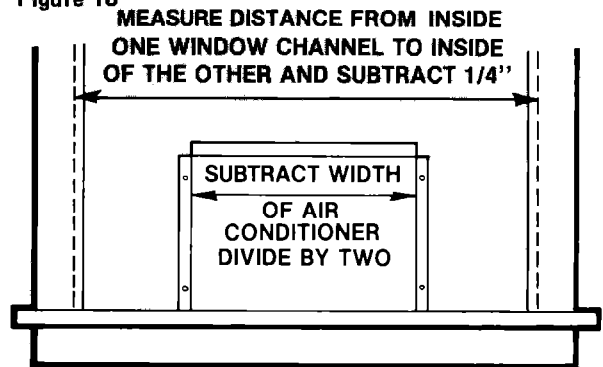

Figure 17



6. Attach side mounting angles to the sides of the cabinet by using four hex-head sheet metal screws. (See Figure 17.) Insert bottom screws first. Be sure flange of each side mounting angle faces inside. Now attach top mounting angle to cabinet by using three hex-head sheet metal screws. Again, be sure tallest flange is facing inside.

Figure 18



- 7.** Measure and cut filler board to proper sizes. First, measure the distance from inside one window channel to the inside of the other channel and subtract $\frac{1}{4}$ ". (See Figure 18 .) Now subtract the width of the air conditioner and divide by 2. This will give you the width to cut each filler board. Be sure to cut the filler board down the mid-section of its longest measurement. Because the filler boards will be equal in width, they will automatically center your air conditioner in your window.

Figure 19

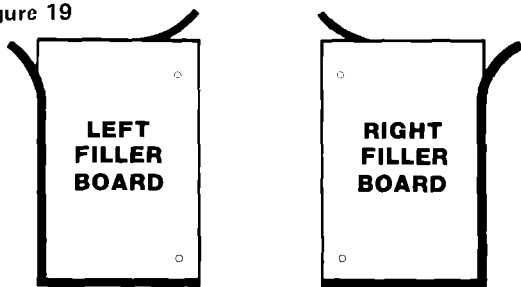

- 8.** Apply seal strips and attach filler boards. Determine which will be your left and right filler boards. The holes on each board should align with the holes in the side mounting angles. Each filler board should also extend about $\frac{1}{2}$ " above the top edge of the air conditioner cabinet. Now apply $\frac{3}{8}$ "-wide seal strips on the room side of each filler board as shown in Figure 19 (i.e. along the bottom edge and window channel edge). Also place a seal strip along the top outside edge of each filler board. Now attach the filler boards to the side mounting angles with four, $\frac{3}{8}$ ", round-headed sheet metal screws. Tighten the screws only loosely, so the filler boards can be moved back and forth.

- 9.** Insert side mounting slides all the way into top mounting channel.

Figure 20

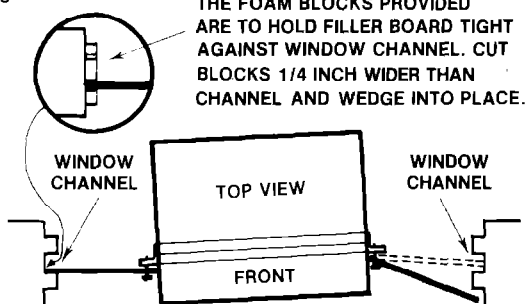

- 10.** Place cabinet in window by turning cabinet to one side to get one filler board into window channel. Now maneuver other filler board into other window channel (see Figure 20). Reaching through window opening, push filler boards from outside as far toward you as they will go. Extend the mounting slides outward into the window channels on both sides. Pull the cabinet toward you to position the side mounting slides as far forward in the window channels as possible. Now mark and make a $\frac{3}{32}$ " pilot hole for each wood screw used to secure the slides in the window channels (see Figure 21). Be sure to use the foam blocks that are provided (see Figure 20).

CAUTION: BE SURE CABINET DOES NOT FALL OUT OF WINDOW.

Figure 21

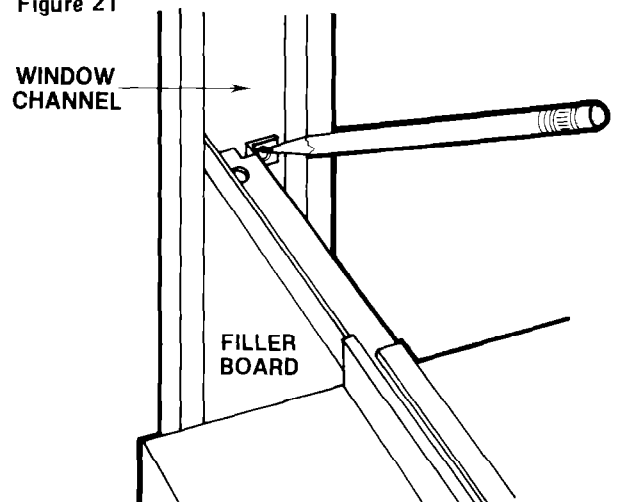
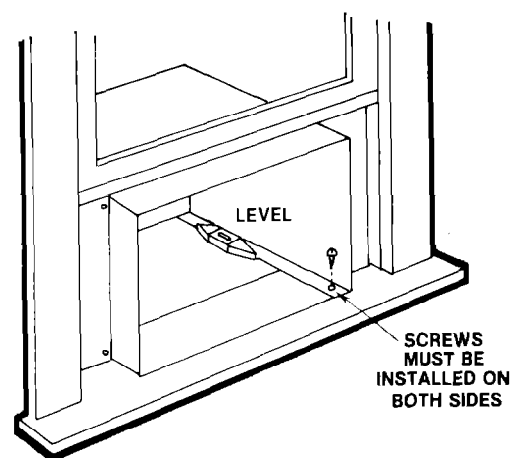
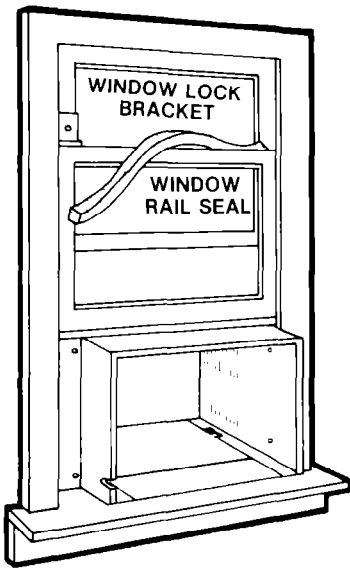

Figure 22



- 11. Lower window and level air conditioner.** Lower the window firmly behind the top mounting channel. Leveling the cabinet is not required in a normal installation since the proper slope is designed into the product. However, be sure you have approximately a one-half bubble (5/8") downward tilt to the outside for proper water drainage. If necessary, reposition or shim cabinet to provide the proper tilt or side-to-side leveling. Now tighten all four filler-board screws. Finally, make two 3/32" pilot holes into the window sill, using the holes in the cabinet as a guide. Use two wood screws to secure the bottom of the cabinet to the window sill. (See Figure 22.)

Figure 23



- 12. Install window seal and window lock bracket.** Press foam window seal into place and cut to proper length (see Figure 23). Install lock bracket using wood screws. Make a 3/32" pilot hole first. (CAUTION: WINDOW LOCK BRACKET *MUST* BE INSTALLED AT ALL TIMES TO BE SURE AIR CONDITIONER DOES NOT FALL OUT OF WINDOW. REMOVE BRACKET ONLY WHEN YOU WISH TO REMOVE AIR CONDITIONER FROM WINDOW.) Seal small openings around installation with gum-type sealer.

- 13. Install plastic drain-cup spout** into hole at rear of cabinet. Spout should be facing downward through hole. OPTIONAL: During high humidity, condensate may drip from the outside of your air conditioner onto the ground below. If your air conditioner is

installed where this is undesirable, you can direct the water to a more suitable spot by simply attaching a 5/8"-inside-diameter, thin-walled hose to the drain spout at rear of cabinet.

- 14. Insert air conditioner into cabinet.** Do not push against sharp fins and plastic parts. Attach green ground wire to the left-front corner of unit base by using retaining screw (see Figure 24). (CAUTION: KEEP WIRE CONNECTED WHENEVER AIR CONDITIONER IS IN CABINET. IT IS THERE FOR YOUR ELECTRICAL SAFETY DURING OPERATION AND MAINTENANCE.)

Figure 24

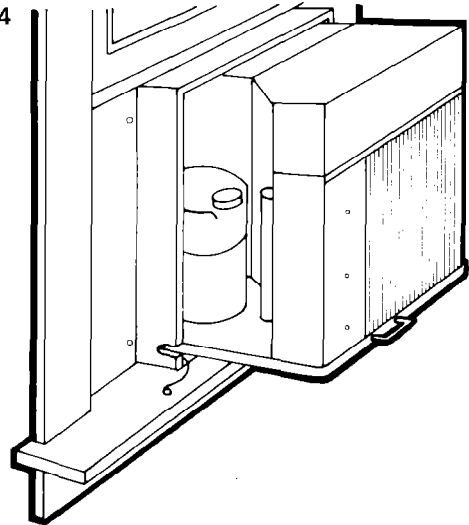

- 15. Attach front by placing bottom edge on clips and pushing top down, then in and up.**

3 Through-the-wall Installation Instructions

... for slide-out chassis model only

- It is the personal responsibility and obligation of the customer to have this product installed by qualified technicians familiar with Through-The-Wall Room Air Conditioner Installations.
- To help avoid any installation problems and to help assure trouble-free performance of your new air conditioner, read these installation instructions, as well as the operating instructions and electrical requirements before installing your unit.

- Because this air conditioner weighs from approximately 125 to 140 pounds, it is recommended that you have somebody help you install your new unit and that you both use proper lifting techniques to avoid personal injury.
- Inspect the condition of the wall where the air conditioner will be installed. Be sure it will support the weight of the unit.

CAUTION:

- Be sure air conditioner does not fall during installation.
- Handle the air conditioner with care. Watch out for the sharp metal fins on the front and rear coils.
- Do not use the collected water for drinking purposes. It is not sanitary.



THIS APPLIANCE MUST BE INSTALLED ACCORDING TO ALL APPLICABLE CODES AND ORDINANCES

1. **Pick the right wall.** First, decide what room(s) you want to cool. Then choose a wall that will allow the air-conditioned air to flow freely and directly into the room(s) you want cooled. Remember, it's difficult to move air around corners. Choose a location that's also near an electrical outlet. (Refer to ELECTRICAL REQUIREMENTS for receptacle and wiring needed.) **Do not use an extension cord.** (CAUTION: DO NOT LOCATE AIR CONDITIONER WHERE PLASTIC CABINET FRONT WILL BE EXPOSED TO A HEAT SOURCE THAT RAISES THE SURFACE TEMPERATURE IN EXCESS OF 120° F.)
2. **Choose the type of decorative molding** you want to use around the room side of the cabinet. Your choice affects the finish frame alignment with the inside wall. When using a wood, metal or plastic molding, the finish frame should almost line up with the inside wall. If the wall is plastered to the cabinet and no molding is used, the finish frame must be set into the wall by 1/2" (see Figure 25 for frame construction or Figure 26 for brick veneer construction). Cut through two studs for support.

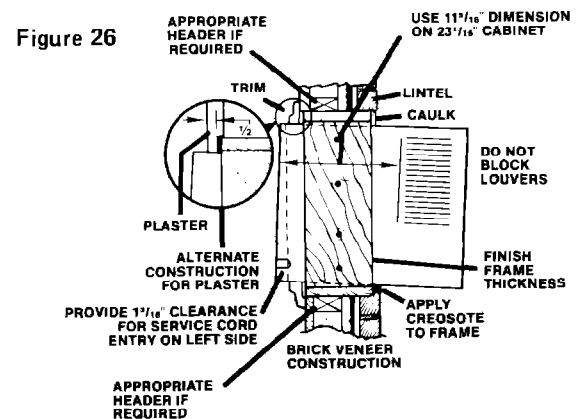
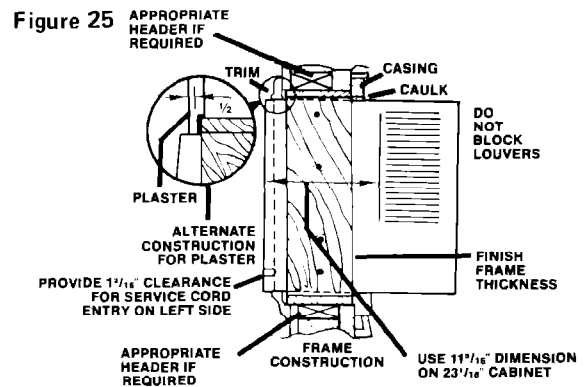

3. **Provide an opening through the wall for a finish frame.** Observe all local governing codes and ordinances. For wall opening dimensions, use those shown in Figure 27 and add wood frame thickness (use 1" lumber or heavier). When determining finish frame thickness, be sure you do not cover side cabinet louvers. A 4" minimum clearance between side cabinet louvers and adjoining wall allows for proper airflow into air conditioner.

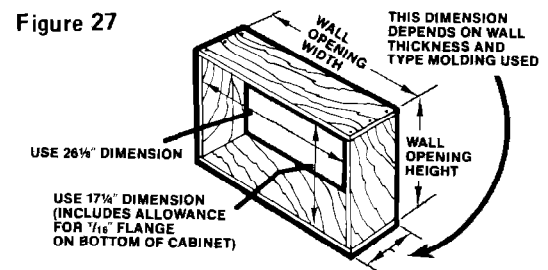

4. **Construct finish frame.** Apply creosote or something equal to the outside exposed surface.
5. **Install the finish frame** in the wall opening. Square and level frame and nail it securely to the studs.

Figure 28

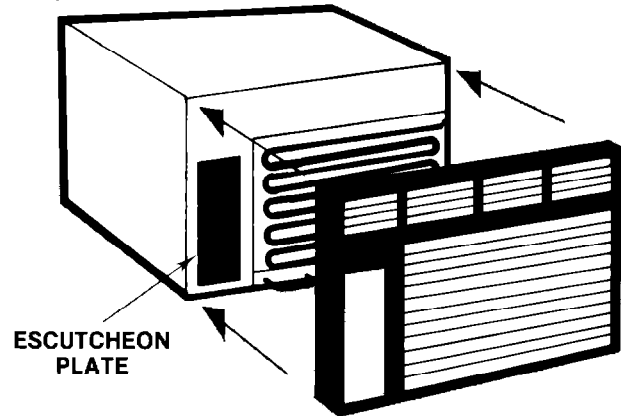

6. The front, escutcheon plate and knobs are packaged separately. This protects the plastic front from damage and makes the air conditioner easier to handle during installation.

7. Slide unit out of cabinet. First, disconnect the green ground wire at the left-front corner of base of unit by removing retaining screw (save screw for reuse later). Now slide unit out of cabinet by pulling on handle at bottom (see page 9, Figure 15).

8. Insert exterior cabinet through wall opening. Leave ½" minimum overhang into the room at top of cabinet, after allowing for trim. For proper outward water drainage, shim or reposition cabinet to provide the proper downward tilt to the outside (½ bubble or 1") and side-to-side leveling.

9. Fill all spaces between cabinet and finish frame with insulation.

10. Drill holes in the cabinet and attach it securely to finish frame. Use ten #10 x 1" wood screws (four screws for each side and two screws for the top; not included). Do not overtighten screws or cabinet will distort and provide a poor air seal between cabinet and unit.

11. Insert air conditioner into cabinet. Do not push against sharp fins and plastic parts. Attach green ground wire to the left-front corner of unit base by using retainer screw. (CAUTION: KEEP WIRE CONNECTED WHENEVER AIR CONDITIONER IS IN CABINET. IT IS THERE FOR YOUR ELECTRICAL SAFETY DURING OPERATING AND MAINTENANCE.)

12. Place escutcheon plate into position. Insert knobs through holes and press them onto shafts (see Figure 28).

13. Attach front panel, place top in position first and push to engage clips. Then engage clips near bottom sides. Clips go inside cabinet flange.

14. Caulk all outside wall openings around cabinet.

Figure 29

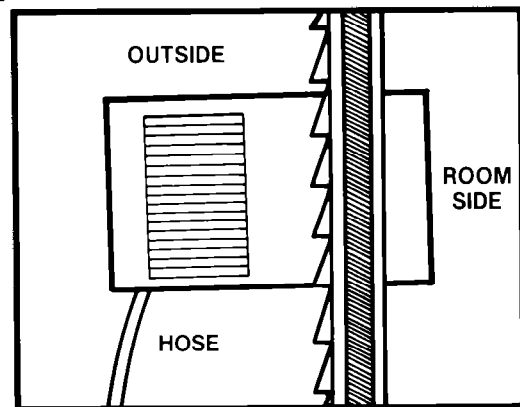

15. If needed, install molding around room side of cabinet. OPTIONAL: During high humidity, condensate may drip from the outside of your air conditioner onto the ground below. If your air conditioner is installed where this is undesirable, you can direct the water to a more suitable spot by simply attaching a 5/8-inch inside-diameter, thin-walled hose to the drain spout at rear of cabinet (see Figure 29).



REFER TO ELECTRICAL REQUIREMENTS AND USE AND CARE INFORMATION FOR ELECTRICAL AND STARTING INSTRUCTIONS.

HOW TO START AND USE YOUR AIR CONDITIONER

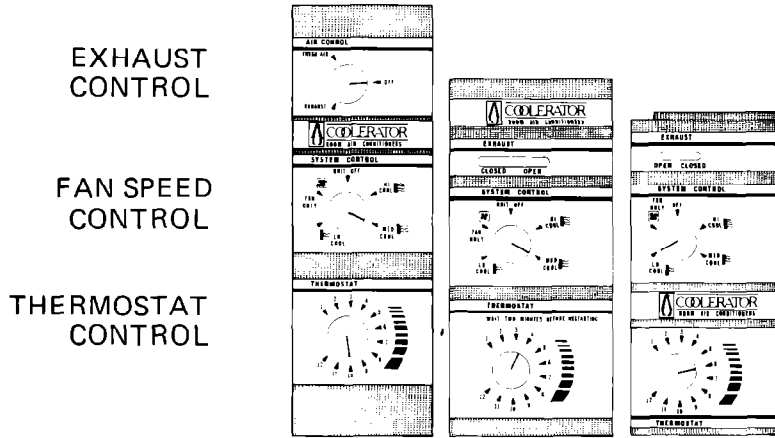

Be sure air conditioner is OFF before plugging it in.

To Start Your Air Conditioner

1. Set exhaust control to OFF or CLOSED for maximum cooling (depending on your model).
2. Choose either LO COOL, MED COOL or HI COOL fan speed setting.
 - LO COOL – for sleeping comfort
 - MED COOL – for normal cooling
 - HI COOL – for maximum cooling
 - FAN ONLY – for circulating room air when when no cooling is desired



CAUTION:
If you turn your air conditioner off, wait at least two minutes before turning it back on or you may blow a fuse.

3. Turn the thermostat control to number 6 (mid-setting). You can adjust the air conditioner's cooling performance by resetting the thermostat control to a higher number for maximum cooling. Lower the number setting for warmer room temperature. You will need to experiment to find the setting which suits you best.

The Exhaust Control

The Exhaust Control setting draws stale or smoky air from the room. On some models, a fresh air setting draws fresh air from the outside into the room.

1. To exhaust room air

Set exhaust control to OPEN. Adjust fan control to speed desired. If no cooling is desired, use FAN ONLY setting.

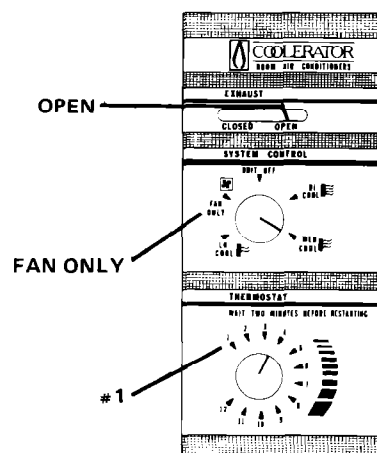

2. To circulate room air

Set exhaust control to CLOSED. Adjust fan control to FAN ONLY.

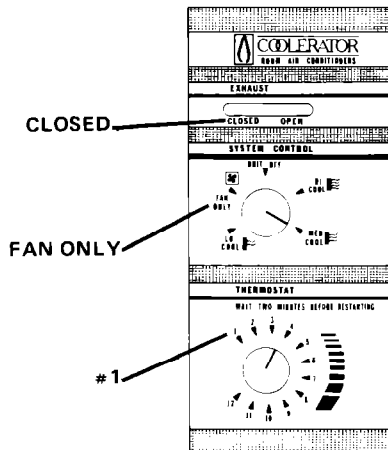

2. To bring in outside air

Set exhaust control to FRESH AIR. Adjust fan control to FAN ONLY.

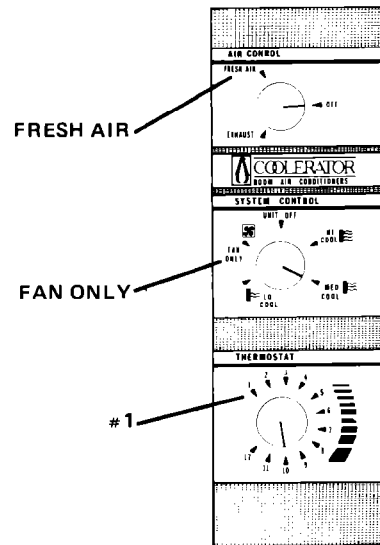

For Exhaust Controls With EXHAUST and FRESH AIR Settings

1. To exhaust room air

Set exhaust control to EXHAUST. Adjust fan control to speed desired. Set thermostat on #1, if no cooling is desired.

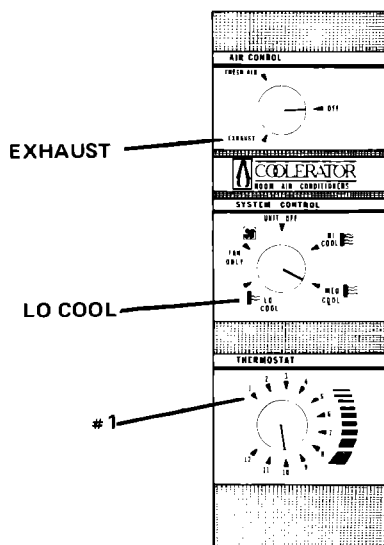

3. To circulate room air

Set exhaust control to OFF. Adjust fan control to FAN ONLY.

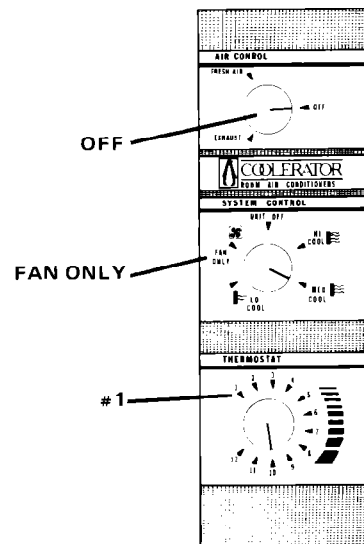

Changing Air Direction

The louvers in the grille area at the top of the air conditioner control the direction of the cooled air.

Figure 30

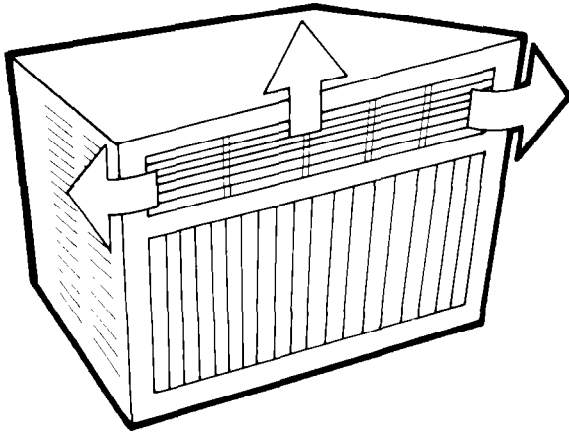

1. Move the tabs at the top or bottom of the grille to the right, left or straight ahead. Simply move the tabs in the direction you want the air to go. (See Figure 30 .)
2. On most models, the louvers can only be adjusted left or right. The front set is fixed and directed upward.
3. On some models, air flow can be directed up or down. Move the tab in the center louver to direct air.
4. On some models, all louvers are fixed. The louvers can not be adjusted.

Cleaning and Caring for Your Air Conditioner

Proper use and care of your air conditioner will help insure longer life and lower operating costs. Follow these instructions carefully. Call your dealer for an annual checkup.

Cleaning of Front Panel



WARNING: DISCONNECT FROM ELECTRICAL SUPPLY BEFORE CLEANING UNIT.

1. Remove the front panel from unit when cleaning. Press down at top edge of the front as shown in Figure 31.

2. When the front moves away from top of cabinet, pull top of front toward you.
3. Lift up and away from the bottom spring clips.



CAUTION:

Do not use cleaning fluids, solvents, abrasive cleaners, or strong detergents. They may damage the parts.

Figure 31

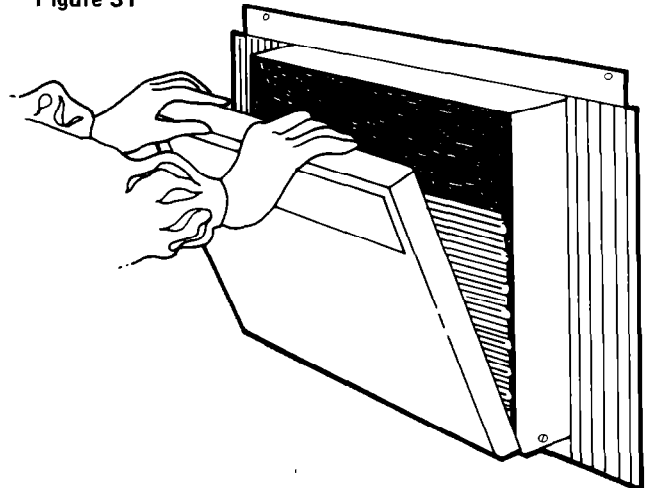

4. Clean front panel with warm water and mild soap or detergent. Use a soft cloth. Rinse and dry. Replace front panel.
5. Wipe control panel clean with a soft dry cloth.

Cleaning Air Conditioner Filter

The filter is cleanable. A clean filter helps remove dust, lint and other particles from the air. Check every two weeks to see if filter needs cleaning.

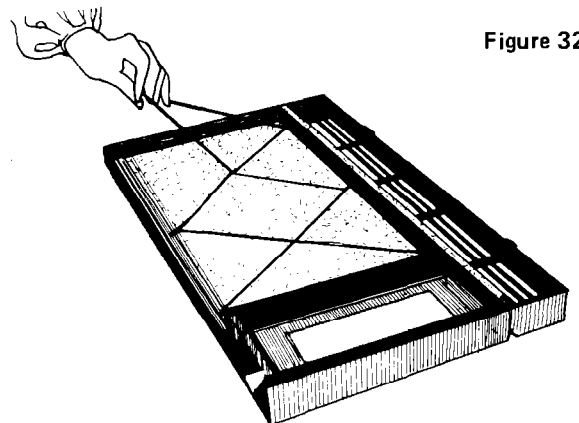

Figure 32

1. Remove filter from plastic front frame, by removing elastic band which holds it in place (see Figure 32).
 2. Clean filter, using a vacuum cleaner.
- OR —
3. If very dirty, wash filter with warm water and mild detergent. Air dry thoroughly before replacing.

Annual Maintenance for Your Air Conditioner

Your air conditioner needs annual maintenance to help insure steady, top performance throughout the year.

Call the service company recommended by your dealer to:

- Inspect and clean the coils and condensate water passages.
- Check fan and oil the fan motor.
- The compressor is sealed and needs no oiling.

Expense of annual inspection is customer's responsibility.

— or —

If you are familiar with electrical appliances, you can do the cleaning and maintenance yourself. If you decide to go ahead, follow these steps:



CAUTION:

Be sure no liquid gets into the motor, electrical control box or compressor electrical terminals.



WARNING:

- SHOCK OR INJURY HAZARD - Before performing any maintenance, be sure to disconnect power cord from receptacle.

1. **REMOVE UNIT FROM CABINET.** Wrap the motor, electrical control box and electrical terminals box in plastic film and make sure no water or other liquid gets inside any of these parts. It could damage the insulation and cause serious trouble.

2. Carefully clean and hose out the base, coils and condensate pans. Clean at least once a year or more often if the condenser coils and pans collect dirt, sand, leaves, insects or algae. Also, clean if you detect an odor from the air conditioner. While the cabinet is open, this is a good time to oil the fan motor.
3. Remove plastic film from motor and electrical parts.
4. Replace unit in cabinet.

NOTE: It's a good idea to wait 24 hours before starting the unit again. This allows time for all areas to dry out. The water from rainfall or from normal operation does not harm these components.

Oiling of the Fan Motor



WARNING:

- SHOCK OR INJURY HAZARD - Before performing any maintenance, be sure to disconnect power cord from receptacle.

1. Oil the fan motor per instructions on the motor. To add oil, pull out the oil hole plug at each end of the motor. (see Figure 33.)

Figure 33

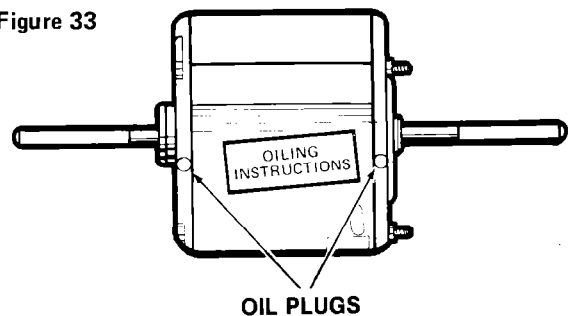

An easy to use one-ounce capsule of especially recommended oil (Part No. 10943) can be ordered from your dealer.

2. Replace the plug to keep dirt from motor bearings.
3. Reinstall the unit in cabinet after performing maintenance. (See Installation Instructions.)

COOLING LOAD GUIDE—SQUARE FEET METHOD

ROOM AIR CONDITIONERS

To make sure you choose the right size unit, use this "COOLING LOAD GUIDE — SQUARE FEET METHOD." It is a quick, easy means of computing capacity.

For extremes in exposure, shading, insulation and building construction, AHAM Cooling Load Estimate Form RAC-1 must be used.

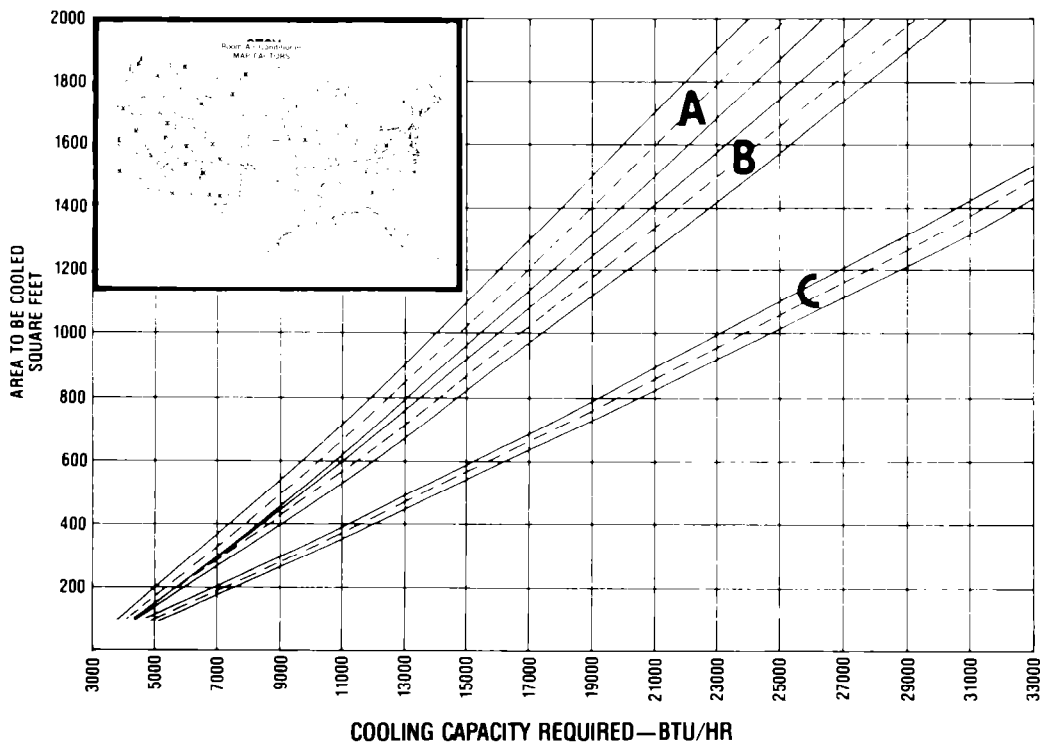

INSTRUCTIONS:

1. Determine the area to be cooled in square feet and locate that point on the left side of chart.
2. Move horizontally across to the center line of Band A, B or C according to the condition of the ceiling in the area to be cooled.
Band A—Occupied Space Above Ceiling
Band B—Insulated Ceiling Under Attic
Band C—Non-Insulated Ceiling Under Attic
3. From center of band move within the band to left for more northerly exposure or right for more westerly exposure.
4. From this point, read down to bottom of chart to determine required Btu/hr output. Write the Btu/hr figure in the space indicated below.

5. _____ Btu/hr (from number 4 above).

6. _____ Locate your geographic area on inset map and multiply factor shown by figure in number 5.
7. _____ If room air conditioner is intended primarily for night-time cooling, subtract 30% (from figure in number 6).
8. _____ Subtract 30 Btu/hr from figure in number 7 (or 6) for each linear foot of wall separating the area to be cooled from another cooled room.
9. _____ If more than two people occupy area, add 600 Btu/hr per person (to figure in number 8); if only one person, subtract 600 Btu/hr.
10. _____ Add 4000 Btu/hr (to figure in number 9) if area to be cooled includes kitchen.

For best results, a room conditioning unit or units with a cooling capacity rating close to that estimated above should be selected. A smaller capacity unit operating continuously will contribute more to comfort than a larger capacity unit operating intermittently.

If you need service or assistance, we suggest you follow these four steps:

1. Before calling for assistance

Performance problems often result from little things you can find and fix yourself without tools of any kind.

Unit won't run:

1. Is unit plugged in?
2. Is switch ON?
3. Is thermostat set too WARM?
4. Is time-delay fuse blown?
5. Has local power failed?

Unit blows fuses:

1. Are time-delay fuses used?
2. Is an extension cord being used? (Do not use.)
3. Are you waiting two minutes after turning cooling circuit off before trying to restart unit?

Unit turns on and off, or does not cool room:

1. Is filter clean?
2. Are coils clean? Both evaporator (inside) and condenser (outside)?
3. Is there excessive moisture or heat? (Open vessel cooking, showers, etc.)
4. Set fan to higher speed.
5. Set thermostat to a cooler setting.

Operating sounds:

1. When your room air conditioner is operating normally, you will hear sounds such as:
 - Droplets of water hitting the condenser, causing a "pinging" or "clicking" sound. Water droplets help to cool the condenser.
 - Air movement from the fan, especially on high fan speed setting.
 - Clicks from thermostat cycle.
2. Sounds also may be caused by house construction — such as vibration of the unit due to wall construction or unsteady window mounting area.

2. If you need assistance

Call the Whirlpool COOL-LINE® service assistance telephone number. Dial free from:

Continental U.S. (800) 253-1301
 Michigan (800) 632-2243
 Alaska & Hawaii (800) 253-1121

and talk with one of our trained Consultants. The Consultant can instruct you in how to obtain satisfactory operation from your appliance or, if service is necessary, recommend a qualified service company in your area.

3. If you need service

Whirlpool has a nationwide net work of franchised TECH-CARE® service Companies. TECH-CARE service technicians are trained to fulfill the product warranty and provide after-warranty service, anywhere in the United States. To locate TECH-CARE service in your area, call our COOL-LINE service assistance telephone number (see Step 2) or look in your telephone directory Yellow Pages under:



<p>APPLIANCES—HOUSEHOLD— MAJOR—SERVICE & REPAIR</p> <p>WHIRLPOOL APPLIANCES FRANCHISED TECH-CARE SERVICE SERVICE COMPANIES XYZ SERVICE CO 123 Maple</p>	<p>OR</p>	<p>ELECTRICAL APPLIANCES— MAJOR—REPAIRING & PARTS</p> <p>WHIRLPOOL APPLIANCES FRANCHISED TECH-CARE SERVICE SERVICE COMPANIES XYZ SERVICE CO 123 Maple</p>	<p>999-9999</p> <p>999-9999</p>
OR			
<p>WASHING MACHINES, DRYERS & IRONERS—SERVICING</p> <p>WHIRLPOOL APPLIANCES FRANCHISED TECH-CARE SERVICE SERVICE COMPANIES XYZ SERVICE CO 123 Maple</p>			
<p>999-9999</p>			

4. If you have a problem

Call our COOL-LINE service assistance telephone number (see Step 2) and talk with one of our Consultants, or if you prefer, write to:

Mr. Robert Stanley
 Division Vice President
 Whirlpool Corporation
 2000 US-33 North
 Benton Harbor, MI 49022

If you must call or write, please provide: model number, serial number, date of purchase, and a complete description of the problem. This information is needed in order to better respond to your request for assistance.



FSP is a registered trademark of Whirlpool Corporation for quality parts. Look for this symbol of quality whenever you need a replacement part for your Whirlpool appliance. FSP® replacement parts will fit right and work right because they are made to the same exacting specifications used to build every new Whirlpool appliance.

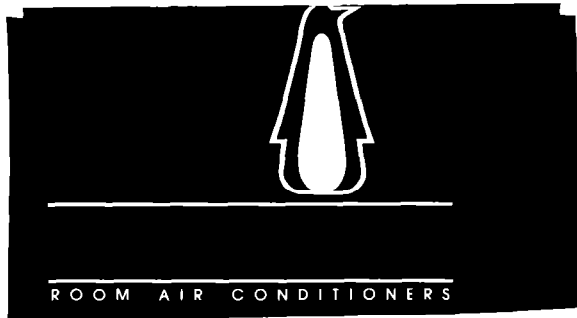

PART NO. 953076A

HEIL-QUAKER CORPORATION

PRINTED IN U.S.A.