

READ THIS

BOOK FIRST



# Instruction Manual

## The Heritage

BH-421-SG-5

*This Is A Revolutionary Gas Grill!*

American Gas Association Design Certified  
Canadian Gas Association Design Certified

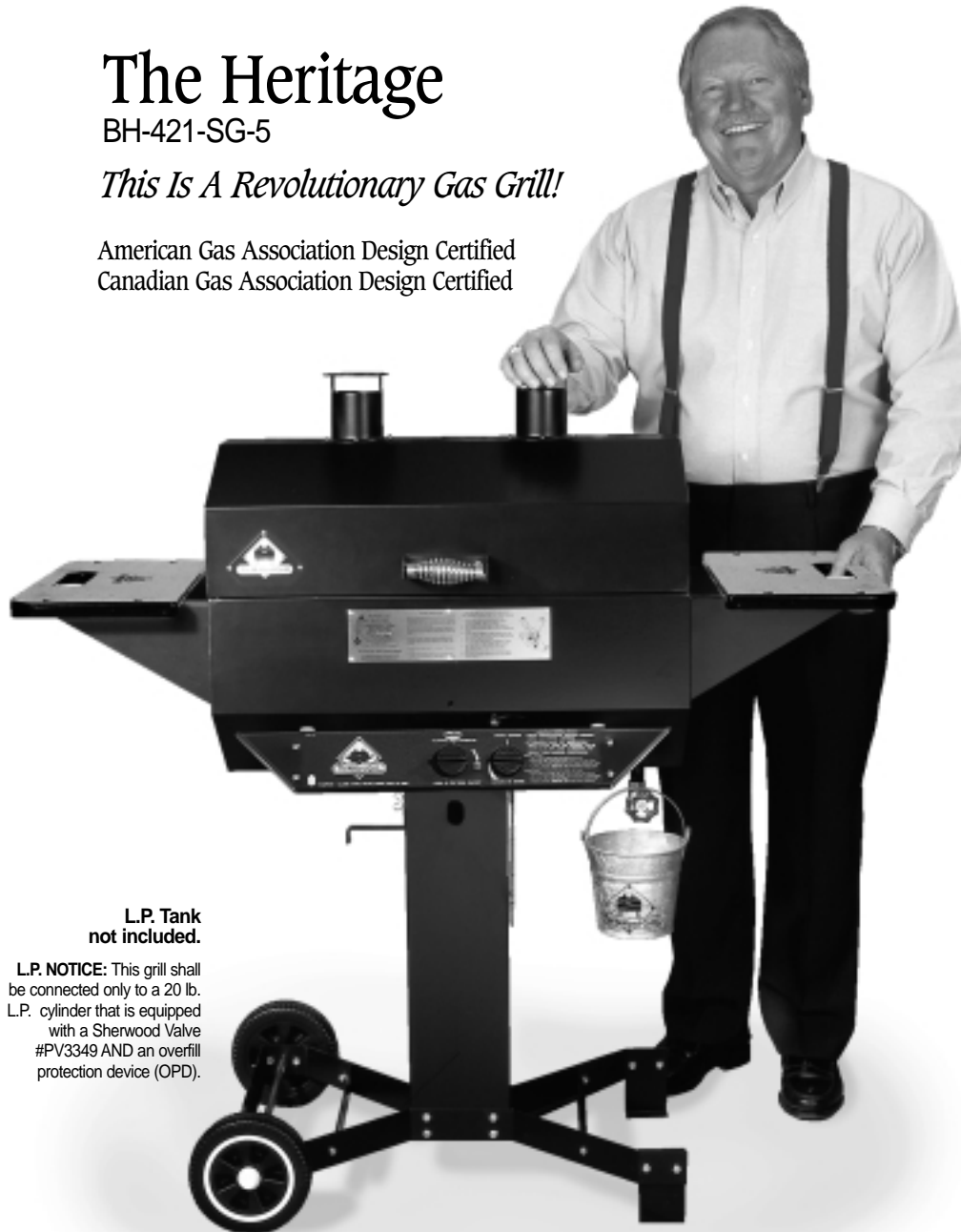

**L.P. Tank  
not included.**

**L.P. NOTICE:** This grill shall be connected only to a 20 lb. L.P. cylinder that is equipped with a Sherwood Valve #PV3349 AND an overfill protection device (OPD).

Heritage 07/99  
PN SG5-002



The only Grill  
**GUARANTEED**  
not to flare up!

*Dear Friend,*

*I wish to personally thank you for purchasing one of my Holland Grills. It's my goal that you, your family and friends enjoy your grill for many years to come.*

*It's important that you are aware that the Holland is unlike any other grill. By design, it allows you to grill, steam or smoke, without the fear of flare-ups commonly associated with competitive brands. Now you can enjoy being with your friends while preparing quality food without the worry and nuisance of trying to control fires.*

*Not only will you be able to enjoy time with friends while you grill in comfort, you'll be able to do so for years to come. My grill is made of quality materials which give it a sturdiness that will last for years. Unlike other grills on the market, I do not intend for my customers to deal with a long list of replacement parts and the inconvenience of waiting for the parts. This grill was designed and made for your trouble-free outdoor cooking.*

*Since the Holland does not operate like other grills, it is important to me that you follow all the instructions. I have spent a large portion of my life developing a product that is safe, easy to use and grills to perfection; I personally want to know your comments, questions or any problems that arise from the grill or our field representatives. Please feel free to contact me with your comments, or contact a local dealer who will help you with parts, accessories, literature and warranty.*

*Thank you,*

*Brad Holland*

**IT'S IMPORTANT THAT YOU, THE OWNER, READ THE ENTIRE MANUAL BEFORE ASSEMBLING OR USING THE GRILL. IF YOU ALLOW SOMEONE ELSE TO USE YOUR GRILL, MAKE SURE THEY HAVE READ THE INSTRUCTIONS AND UNDERSTAND THEM BEFORE YOU LET THEM OPERATE THE GRILL.**

# OWNERS MANUAL

## FOR YOUR SAFETY

IF YOU SMELL GAS:

1. SHUT OFF GAS TO THE APPLIANCE.
2. EXTINGUISH ANY OPEN FLAME.
3. OPEN LID.
4. IF ODOR CONTINUES, IMMEDIATELY CALL YOUR GAS SUPPLIER OR FIRE DEPARTMENT.

## FOR YOUR SAFETY

1. DO NOT STORE OR USE GASOLINE OR OTHER FLAMMABLE VAPORS AND LIQUIDS IN THE VICINITY OF THIS OR ANY OTHER APPLIANCE.
2. AN LP CYLINDER NOT CONNECTED FOR USE SHALL NOT BE STORED IN THE VICINITY OF THIS OR ANY OTHER APPLIANCE.

## IMPORTANT

The grill should be lit and allowed to operate for at least 30 minutes before using for the first time to allow preservative to burn off. After smoke stops coming out of stacks, grill is ready for your use and enjoyment.

THIS GRILL IS NOT FOR  
COMMERCIAL USE

THIS GRILL IS NOT INTENDED TO BE  
INSTALLED IN OR ON RECREATIONAL  
VEHICLES AND/OR BOATS

THIS COOKING APPLIANCE IS FOR  
OUTDOOR USE ONLY AND SHALL  
NOT BE USED IN A BUILDING,  
GARAGE OR ANY OTHER  
ENCLOSED AREA.

THIS GRILL SHALL ONLY BE CON-  
NECTED TO AN LP CYLINDER WITH AN  
OVERFILL PROTECTION DEVICE (OPD).

**SAFETY INFORMATION**  
~~EXCESSIVELY WINDY OR COLD~~  
CONDITIONS MAY AFFECT GRILL  
COOKING PERFORMANCE

## WARNING: FOLLOW LOCAL CODES

The installation of this appliance must conform with local codes or in the absence of local codes, conform to the National Fuel Gas Code ANSI Z223.1.

Installation shall be in accordance with CAN/CGAB149.1 natural gas installation code or CAN/CGA-B149.2 propane installation code and local codes where applicable.

## YOUR GRILL IS MADE FOR OUTDOOR USE ONLY

A minimum clearance of 18 inches on the sides and back must be kept between the grill and combustible construction. The grill shall not be located under overhead unprotected combustible construction.

THE VENT STACKS AND THE INTAKE AIR OPENING should never be blocked or closed while operating.

## THE FUEL SYSTEM

Gas grills are used SAFELY by millions of people when following simple SAFETY precautions.

The items in the fuel system are designed for operation with the Holland Grill. They must not be replaced with any other brand. (See parts list for replacement items.)

**GAS BURNER:** The gas burner is made of heavy cast iron and should not require maintenance other than inspection for insect nests inside the venturi. If you remove the burner for cleaning, it must be reinstalled exactly as removed.

**AIR SHUTTER:** See Item 11 in lighting instructions (See figure 6 for details.)

- (a) Do not store a spare Lp-gas cylinder under or near this appliance;
- (b) Never fill the cylinder beyond 80 percent full; and
- (c) If the information in "(a)" and "(b)" is not followed exactly, a fire causing death or serious injury may occur.

**BURNER VALVE:** The burner valve is operated in only two positions. The Off position is when the knob bar is Horizontal, the pointer is at the OFF mark. This stops the flow of gas. When the valve has been set in the OFF position, it is important to also close the valve on the LP tank or Natural gas supply. The On position is when the knob bar pointer is straight up, at the ON/LIGHT position. The burner valve controls the heat allowed in the grill by means of a plug orifice. This device is set at the factory and must not be tampered with. See Lighting instructions for more information.

ONLY A FACTORY SUPPLIED VALVE SHOULD BE USED. (See the parts list for replacement items.)

**LP GAS HOSE:** The LP gas hose is designed for use with LP gas only. Use with any other gas is dangerous. The hose is made of a flexible material to make it easy to install. This material is subject to considerable twisting and turning during installation. It is very important that the hose be inspected for cracks, cuts, abrasions, wear and loose fittings. The visual inspection should include leak testing the entire length of hose and fittings. (See final assembly instructions for more information.)

If the hose shows signs of damage or leakage, it must be replaced prior to the operation of the grill. Only a factory authorized replacement part can be used. (See the parts list for replacement items.) Failure to properly inspect or replace hose with an authorized replacement may result in accident or injury.

## LP GAS REGULATOR - CAUTION -

The gas pressure regulator provided with this appliance must be used. This regulator is set for an outlet pressure of 11 inches water column. Substitution of regulator by any other device or any other manufacturer's regulator is dangerous and could result in serious injury. (See the parts list for replacement items.)

**PROPANE FUEL:** Warning – propane is a flammable gas and improper handling may result in explosion and/or fire and serious accident or injury. Your grill is designed to operate on LP gas and is equipped with the proper orifice for this gas. **CAUTION:** Do not connect this grill to any gas supply except propane or natural gas. Propane gas is heavier than air and will settle in low areas. Make certain adequate ventilation is available when using your grill and that the gas cylinder is stored outside in a well ventilated place out of reach of children when the grill is not in use.

**LP GAS CYLINDER:** This grill is designed and intended to be used with an LP gas cylinder with a nominal LP gas capacity of 20 pounds. Such a cylinder is approximately 12-3/8" in diameter with an overall height of 18-1/16". The Holland Grill does not come with an LP gas cylinder. This must be purchased separately and is available at most hardware stores. The cylinder used must be constructed and marked in accordance with the specifications for LP gas cylinders of the U.S. Department of Transportation (DOT) (4BA-240) and the National Standard of Canada CAN/CSA-B339, cylinders, spheres, and tubes for the transportation of dangerous goods. Only a cylinder equipped with an overfill protection device (OPD) should be used.

THE LP GAS CYLINDER shall be used only outdoors in a well ventilated space and not in a building, garage, or any other enclosed area. The LP gas cylinder is designed to be used, stored, and transported in the upright position. The Holland Grill may be stored indoors if the LP gas cylinder is removed and stored outdoors. NEVER turn the cylinder upside down or on its side. Always transport, store and use your cylinder in the upright position.

FIGURE 1-A

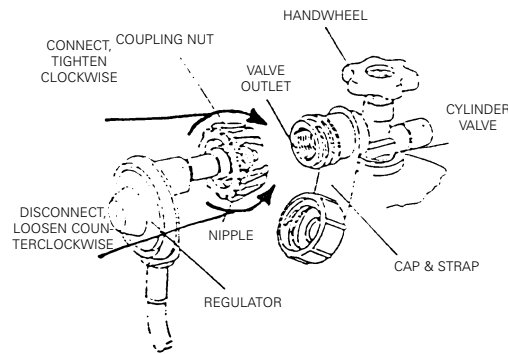

The cylinder must be provided with a Sherwood valve, part #PV3349, which will connect with (quick connect) the QCC-1 Fitting provided on each of our LP (propane) grills. Must also have a safety relief device having a direct communication with the vapor space of the cylinder. The cylinder supply system must be arranged for vapor withdraw. The cylinder shall include a collar to protect the cylinder valve. The grill must be connected to the gas supply by a hose.

**DO NOT transport a full or empty gas cylinder in a closed automobile trunk or in a closed passenger area.**

Filling the gas cylinder requires removing it from the grill. The cylinder is attached to the grill by connecting the regulator assembly to the inlet portion of the gas cylinder valve. This connection is made by the QCC-1 fitting pictured in Figure 1-A. The large plastic nut fits on the outside of the threads and turns right, or clockwise to tighten. No tools are necessary. Hand tight is sufficient. If a good connection is not achieved, the safety valve inside will not permit the proper amount of gas to flow. When connecting the regulator to the cylinder valve, be sure the pressure relief valve is directed away from the front and away from the grill. If the relief valve should open, the propane will be directed where it is likely to do the least harm. To disconnect regulator assembly turn large plastic nut left or counter-clockwise.

When disconnecting and connecting the gas cylinder, be careful that the regulator assembly does not strike the grill, the ground, or any other surface. If any difficulty at all is had in connecting or disconnecting the regulator assembly to the cylinder valve, contact your local gas supplier for assistance.

When disconnected from the cylinder, a valve cap must be installed. (See figure 1-A.) Failure to install a valve cap when the cylinder is disconnected from the fuel system is dangerous and may result in accident or injury.

When reconnecting the LP gas cylinder, be sure to tighten the fitting until snug. This connection, as well as all other fittings and connections between the cylinder and burner valve, should be inspected for damage and leak tested after every filling or reconnection. (See lighting instructions, Figure 8.)

Keep any electrical supply cord and fuel supply hose away from any heated surface.

**NATURAL GAS:** If natural gas is used, contact your local supplier to set it up properly. The N.G. Holland Grill is set to operate at 7 inches water column pressure, using an orifice with a #48 drill size. If your grill seems too hot, first call your local gas company to determine what pressure you have. Never allow anyone to change orifice size without authorization from factory.

### Spark Ignitor:

This grill is equipped with a rotary Piezo ignitor system. A simple Clockwise rotation of the ignitor knob produces a spark at the burner head, lighting the burner. To check that the spark ignitor is working properly, leave gas supply turned OFF and observe the spark by looking through the peep hole above the control panel or from below the control panel to the left side of the burner in the burner opening. A small blue spark should be visible at the left side of the burner head every time the ignitor "fires". A loud "hammer" like sound is produced by the mechanism when sparking.

# HERITAGE ASSEMBLY INSTRUCTIONS

## Model BH 421 SG-5

### TOOLS NEEDED FOR ASSEMBLY

1. 7/16" NUT DRIVER
2. 7/16" WRENCH
3. PHILLIPS SCREWDRIVER
4. 3/8" NUT DRIVER

The Holland Grill has been designed for easy assembly. Most of the main grill body components are pre-installed at the factory. The items to be assembled are outlined at each step below.

#### BEFORE BEGINNING

PREPARE A FLAT OPEN WORK AREA SUCH AS A GARAGE FLOOR OR PATIO. OPEN AND EMPTY ALL BOXES AND CHECK CONTENTS TO SEE THAT NO PARTS ARE MISSING.

1. On a flat surface (table or carport floor), OPEN AND EMPTY BOTH BOXES. REFER TO THE CONTENTS LIST TO BE SURE NO PARTS ARE MISSING.

2. Refer to Figure 2. Select the following parts for assembly:

- |     |                        |
|-----|------------------------|
| No. | Description            |
| 1.  | Stand Tube             |
| 2.  | (2) Stand Tube Support |

2a. Set stand tube upright with the end having 4 holes on floor and the round access hole in front. Slide tube supports against each side of tube, aligning four holes on each side. Start, but don't tighten, eight bolts and lock washers.

2b. Select left mid-brace (part 4). Place it as shown in Figure 2. Be sure notches are up and narrow flange is away from stand tube.

2c. Repeat for right mid-brace (part 5).

2d. Select axle brace (part 6). Place it between left ends of stand support. Attach it to supports with two bolts, nuts and washers at each end. Be sure notches are up and narrow flange is toward stand tube. AT THIS POINT, TEMPORARILY INSERT AXLE THROUGH HOLES IN LEFT END OF STAND SUPPORT AND AXLE BRACE.

be sure stand tube and supports are flat on the floor and tighten all bolts securely.

2e. Install a stand foot (part 7) at the end of each stand support having only two holes. Be sure the narrow flanges are nearest the floor and facing each other.

3. Refer to Figure 3. Select the following parts for assembly:

- |     |                   |
|-----|-------------------|
| No. | Description       |
| 8   | Axle              |
| 9   | Push Nut (2 each) |
| 10  | Wheel (2 each)    |

3a. Remove axle from stand support, and install a push nut (part 9) on one end and seat it with a sharp hammer rap. Use a block of wood to protect the nut.

3b. Slide a wheel (part 10) onto axle with whitewall toward nut.

3c. Reinsert axle into stand support, slip second wheel into place with whitewall out and install second push nut as before.

4. Carefully remove the parts inside the grill bottom and invert the bottom.

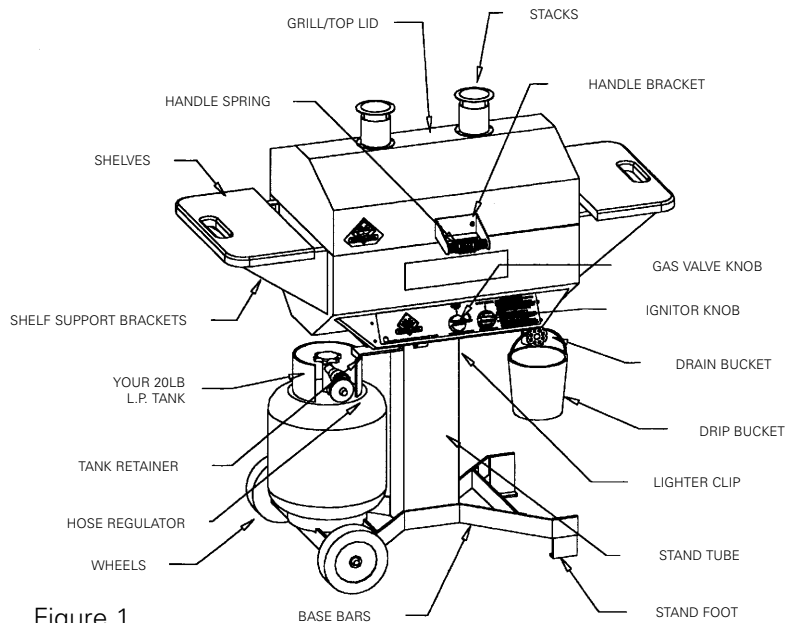

Figure 1

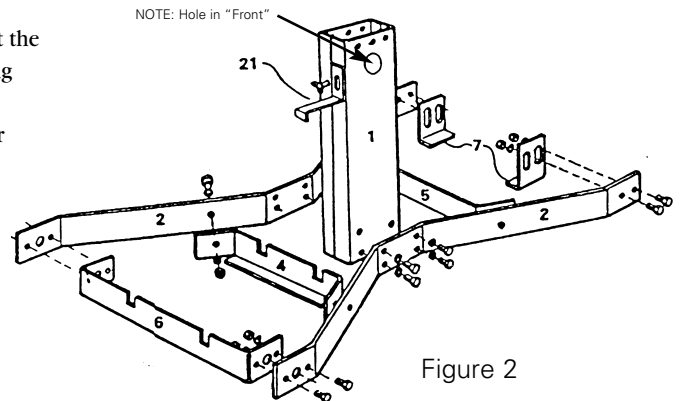

Figure 2

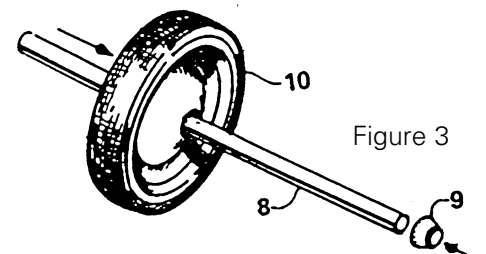

Figure 3

Select the following parts for assembly:

- |     |                       |
|-----|-----------------------|
| No. | Description           |
| 11  | Grill bottom assembly |
| 12  | Ignition electrode    |
| 13  | Bottom mount          |
| 14  | Shelf brackets (4)    |

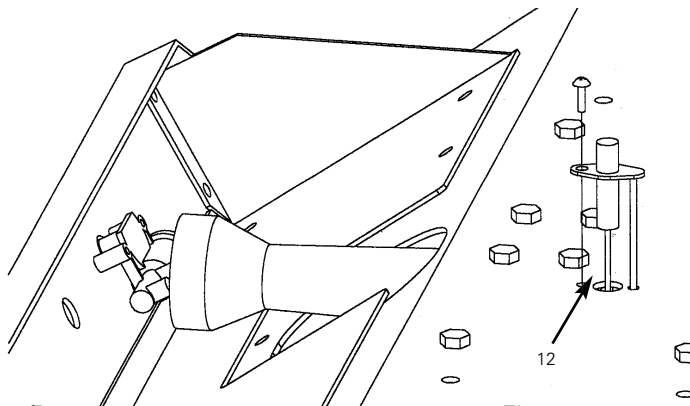

Figure 4a

4a. Refer to Fig. 4a

Install the ignitor electrode into the grill bottom as shown using a #8-32 screw to secure. Leave the electrode wire loose for now.

4b. Refer to Fig. 4b

Locate the grill bottom mount bracket to the grill bottom with the clearance holes in the bracket fitting over the bolt heads for the flame deflector plate. Install the 1/4-20 bolts and lockwashers to secure.

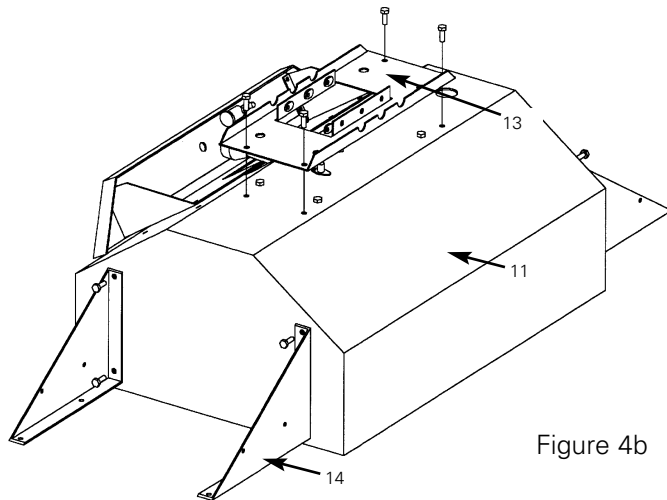

Figure 4b

Attach the (4) shelf brackets to the grill bottom while it is still upside-down. Use the 1/4-20 bolts and lockwashers to secure.

4c. Refer to Fig. 4c

Invert the stand tube and support assembly (previously assembled) and position it over the grill bottom mount. CAREFULLY feed the electrode wire up into the stand tube and out through the hole in the front of the tube as you lower the stand tube assembly in place. Slip the open end of the tube OVER the projecting flanges of the bottom mount. Align the three holes in each side and install a bolt and lockwasher in each. When all are started, tighten securely.

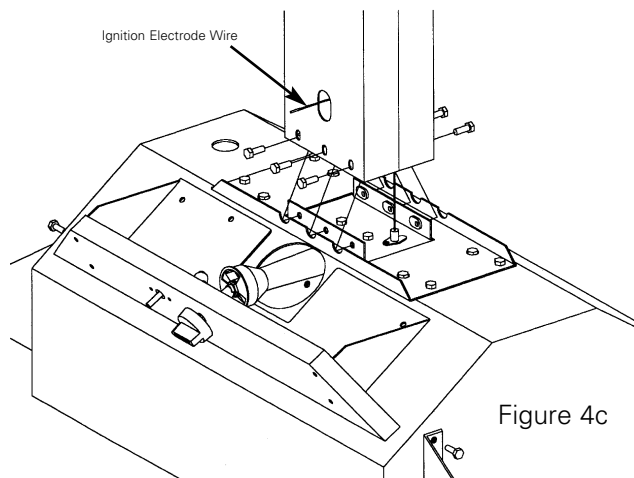

Figure 4c

4d. Refer to Fig. 4d

Attach the loose end of the electrode wire to the terminal on rear of ignitor body on back of control panel.

#### SPARK IGNITOR

At this point you should check to see that the Spark Ignitor is working properly. Rotate the Ignitor knob CLOCKWISE and observe the electrode tip inside the grill body, next to the burner head. You should see a small blue spark upon every actuation of the spark mechanism.

After the stand tube assembly and shelf brackets are installed and the ignitor is working correctly, turn the grill over onto its wheels.

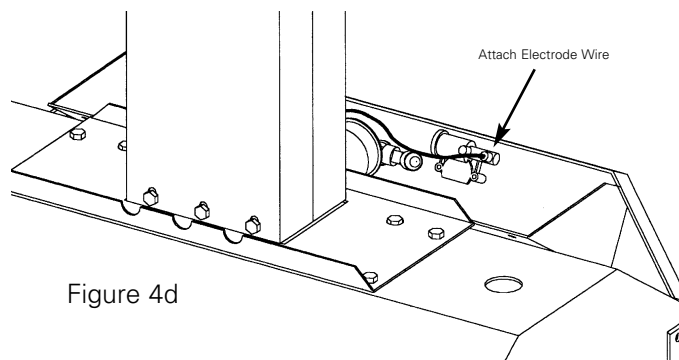

Figure 4d

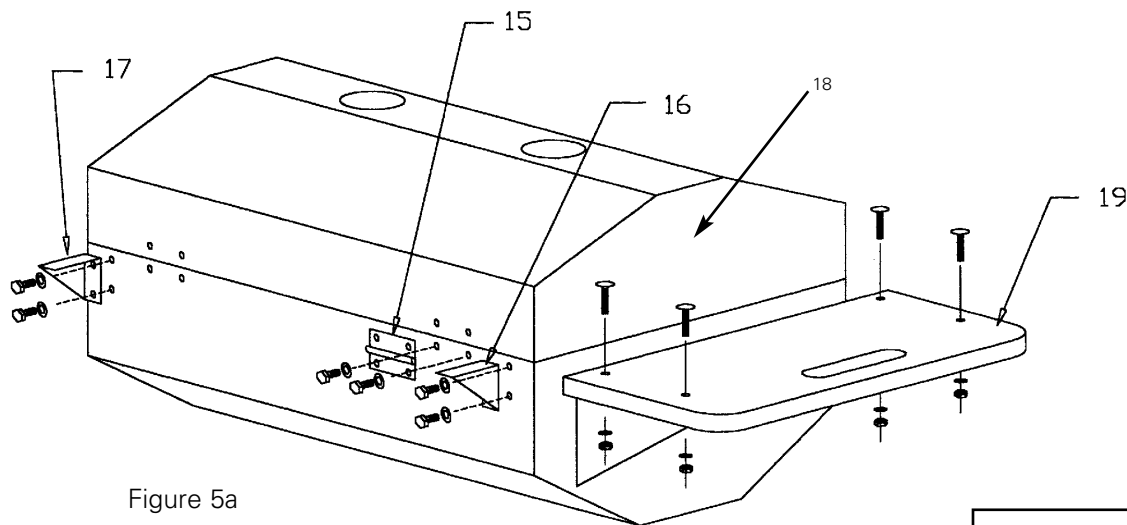

Figure 5a

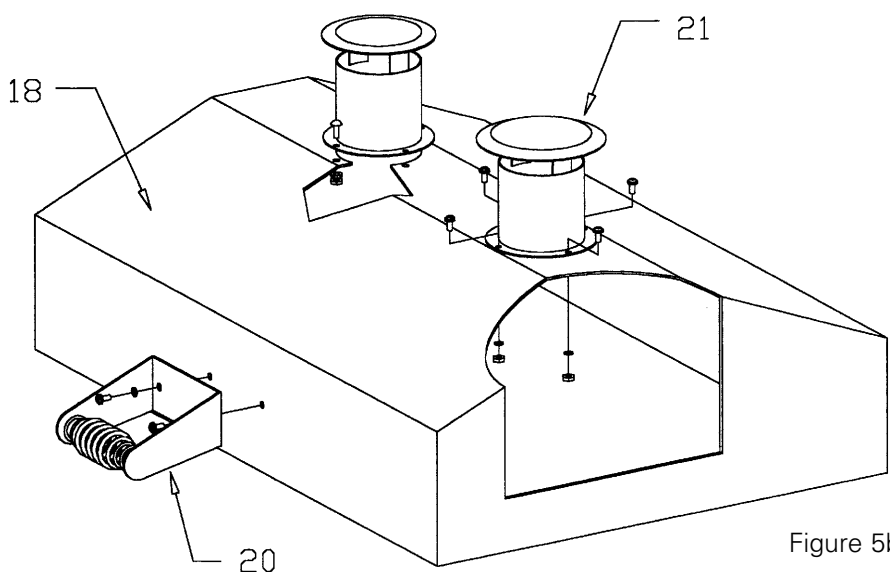

Figure 5b

NOTICE: if your grill wobbles after putting it in place, adjust the higher of the two feet by loosening the two nuts and bolts retaining it and slide the foot down until it contacts the floor, and retightening the nuts and bolts. be sure the narrow flanges are nearest the floor and facing each other.

Refer to Fig. 5a

Select the following parts for assembly:

No.	Description
15	Hinges
16	Grill Lid Stop, Left
17	Grill Lid Stop, Right
18	Grill top/lid

Place the grill top squarely onto bottom. Attach hinges to grill bottom and top with 1/4-20 bolts and lockwashers. Attach the lid stops using the 1/4-20 bolts and lockwashers. The flanges should point IN toward each other.

6. Refer to figure 5a

Select the two shelves (part 19) and secure to the self brackets using the #10-24 carriage screws, lockwashers and hex nuts.

7. Refer to Fig. 5b

Select the grill top handle (part 20) and secure it to the lid using 1/4-20 bolts and lockwashers, Insert the handle spring into the handle bracket. Attach the stacks (part 21) to the lid using (4) #10-24 phillips screws, lockwashers and hex nuts.

8. Install the short length of drain pipe into the female threaded coupling in the drip pan. Tighten with pliers or pipe wrench.

9. Open the grill top against the lid stops. Carefully set the drip pan into the grill bottom using the lifting tabs provided at each end. The drip pan sets down into brackets in each end of the body. Be sure the drain pipe extends down through the hole in the grill bottom.

10. Install the brass drain valve by threading it onto the end of the drain pipe extending from the bottom of the grill. Check to be sure that the valve is OPEN.

11. Place your 20lb. Propane tank into the notches in the base bars. Attach the tank retainer to the stand tube using the 1/4-20 wingbolt. Adjust the retainer to secure the tank.

12. Install the regulator onto the propane tank valve. This connection is made by the QCC-1 fitting. The large plastic nut fits over the outside of the tank valve inside will not permit the proper amount of gas to flow.

13. Hang drip pail over the brass drain valve.

14. Check all bolts and nuts for tightness and proceed to leak testing. (Soapy water test)

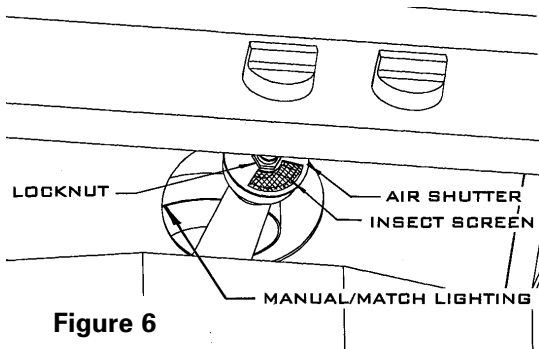
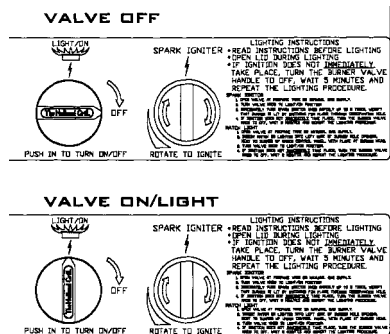
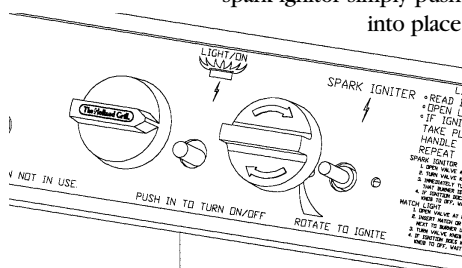

Figure 6



**Knob Installation**

The knobs for the gas valve and spark ignitor simply push into place



NOTE: The Holland Grill uses a 2-position gas valve for burner control. Figure 6 shows the valve knob in the OFF position. To turn ON, push knob DOWN (towards control panel) and turn counter-clockwise for its full travel (90degrees). NEVER operate the Holland Grill with the handle in any intermediate position.

**FOR NATURAL GAS SUPPLY**

The Holland Grill, including the gas off-on valve, must be disconnected from the gas supply during any pressure testing of that system, at test pressures in excess of 1/2 psi.

The Holland Grill must be isolated from the gas supply piping system by closing the individual manual shut-off valve during any pressure testing of the gas supply piping system at test pressure equal to or less than 1/2 psi.

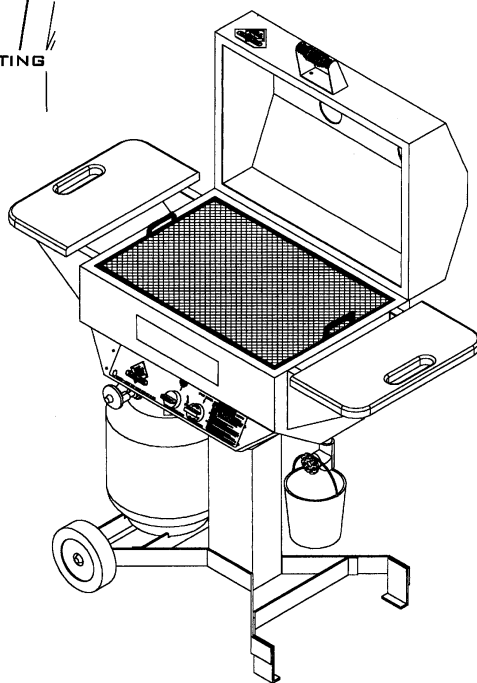

Lid always open when lighting.

**SOAPY WATER TEST**

In a small bowl mix half liquid detergent and half water. Turn on propane tank valve. Using a small brush, soap all connections from tank to grill and look for bubbles. Correct all leaks before proceeding. Turn off propane tank valve.

**LIGHTING INSTRUCTIONS**

See Figure 6

1. Make sure the propane tank valve and the burner valve are both fully off.
2. Open the grill lid and allow five full minutes to air out.
3. During this time, inspect the gas system for damaged hose or loose fittings. Check the hose for wear, abrasions, cuts or kinks. If any damage is found, replace hose using only factory-approved replacement hose. Never attempt to light this or any gas grill with a cracked, split, braided, or severely kinked hose or with any broken or leaking fittings.

**SPARK IGNITOR LIGHTING**

4. Open valve at propane tank or natural gas supply
5. Turn the valve 90 degrees counter-clockwise to the ON position.
6. IMMEDIATELY TURN THE SPARK IGNITOR KNOB RAPIDLY, UP TO 5 TIMES.
7. If ignition does not IMMEDIATELY take place, turn the burner valve knob to OFF, WAIT 5 MINUTES and repeat the lighting instructions.

**MANUAL/MATCH LIGHTING**

8. Open valve at propane tank or natural gas supply. Insert match or lighter into left side of burner hole opening, next to burner, up under control panel, with flame next to burner head.
9. Turn valve knob to ON position. If ignition does not IMMEDIATELY take place, turn the burner valve knob to OFF, WAIT 5 MINUTES, and repeat the lighting instructions.
10. When the burner lights remove the match or lighter.

**ADJUSTING AIR SHUTTER**

11. Loosen the locknut with an open end wrench, so you can turn the air shutter. Adjust the air shutter slowly. When most of the orange has left the flame, and it has become uniformly pale yellow-to blue, the flame is properly set. There should be no need to re-adjust the air mixture for the life of your grill, but it is wise to check the flame color each time you light your grill. Use the peep hole just above the control panel to observe the flame.

The flame should be blue in color, with slight yellow at the tips. Yellow-tipping not unusual and will not affect the performance of the grill.



PROPER AIR SHUTTER SETTING

After air shutter adjustment, your grill is ready for use—proceed to COOKING INSTRUCTIONS.

If the burner did not light properly, wait 5 minutes before attempting re-light, then repeat steps above

If the grill fails to light after the second attempt, call your local LP gas dealer for professional assistance.

With the burner lit, gently close the lid and allow the grill to warm for 20-30 minutes.

NOTE: If for any reason the burner should go out, shut off gas at the burner and the LP cylinder. DO NOT attempt to re-light without repeating steps 2-10.



## TURNING GRILL OFF

1. Open lid
2. Turn burner valve OFF
3. Turn LP cylinder valve OFF
4. CAUTION: Do not attempt to relight without following all lighting instructions.

### IMPORTANT:

Always shut off the burner valve before closing the tank/gas supply valve. This grill is equipped with a QCC-1 flow-limiting connector which will not reset to allow full gas flow if the supply valve is closed before the burner valve is shut off. If you experience trouble with the grill not heating properly, shut off burner valve, then tank or supply valve. Open lid, wait 5 minutes and follow lighting instructions.

## CARE AND MAINTENANCE

There is very little care and maintenance needed. The Holland Grill is designed and made of materials that will last many years with normal use. Following these instructions will improve the longevity and quality of cooking. To assure safe operation of your Holland Grill, the area for cooking should always be kept free of combustible materials of any type, such as gasoline or other flammable vapors or liquids.

A. Outside of body – This is aluminized metal. It can be cleaned easily with warm, soapy water or mild cleaner. If paint gets scratched, remove grease and repaint with a heat resistant paint. The metal surface will last longer. Do not use wire brushes, scrapers or abrasive cleaners for normal cleaning.

B. Grid and Drip Pan – The grid is made of high quality stainless steel. The grid should be brushed with a brass, copper, or stainless steel brush immediately after removing food while grill is still warm. The drip pan is aluminized steel and can be cleaned with a flat scraper such as a putty knife. CAUTION: The drip pan must be kept clean and free of heavy build-up for grill to perform properly, and to eliminate flare-ups. Do not wash drip pan.

C. Inside Grill – Use warm soapy water to clean this area. Do not allow grease to build up.

D. Drain Pipe and Valve – Both must be kept clear of grease and food particles to allow grease to drain properly from drip pan. This must be done to maintain proper operation of your grill.

E. Food Board – This is made from high density polyethylene, approved by the FDA for direct food contact. Warm soapy water can be used for cleaning. CAUTION: It should not be used as a chopping block, nor should more than 15 pounds be placed on it at any time.

F. General – This grill, like all equipment, will look better and last longer if kept out of weather when not in use. CAUTION: Do not store gas tank in closed areas. See instructions or local gas ordinances for care and storage of propane tanks. When using a cover, never place it on the grill until the entire unit has cooled at least 30 minutes.

Check to be sure all openings into the grill body are free of blockages or debris. Make sure there are no objects or materials blocking the flow of combustion and ventilation air.

When grill is not in use, the gas must be turned off at the supply cylinder.

For outdoor use only. If stored indoors, detach cylinder and leave it outdoors.

Cylinders must be stored outdoors out of reach of children and must not be stored in a building, garage or any other enclosed area.

Check burner venturi behind air shutter screen for insect nests or blockages. Make sure the passage through the burner venturi is not obstructed.

If the burner valve is ever removed for cleaning or replacement, it should be re-installed to the dimension shown below. Measure from the center of the valve handle to the face of the burner air shutter. This assures correct positioning of the orifice in the burner venturi.

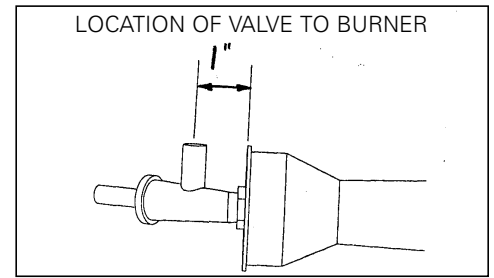

IMPORTANT - FIRST TIME USE: It is important that the grill be lit and allowed to operate at least 30 minutes before any food is placed on the grill grid. Some smoke may appear during this period. This is the preservative used during manufacturing. After initial heating, the grill is ready for use. After burning off the grill, spray the food grid, drip pan and the inside of the lid with PAM or similar spray, so food does not stick to the grid and the inside is easier to clean.

## MOVING INSTRUCTIONS

### CAUTION: NEVER MOVE GRILL WITH BURNER LIT OR WITH WATER IN DRIP PAN.

A. Moving in your yard or deck: Make sure gas is turned off at burner valve and tank valve. Be sure lid is closed. Lift by the shelf on the end without wheels. Push your grill to desired location, first checking for holes or obstacles that may cause tripping or falling. Make sure grill is level before using.

Moving on trailer or truck: Follow all steps above. Before loading, secure lid closed by tying rope or bungee cord from handle to the cross brace between the leg assemblies. After loading, be sure to tie down securely to prevent damage.

NEVER transport your grill with propane tank connected.

CAUTION: Always secure propane tank tightly to truck or trailer.

THIS COOKING APPLIANCE IS FOR OUTDOOR USE ONLY AND SHALL NOT BE USED IN A BUILDING, GARAGE OR ANY OTHER ENCLOSED AREA.

## COOKING INSTRUCTIONS

ALLOW GRILL TO WARM UP WITH LID CLOSED FOR 20 - 30 MINUTES PRIOR TO COOKING.

A. It is important to realize cooking on a Holland Grill uses a different process in order for the grill to perform correctly. It is essential that the lid remain closed while grilling. NOTE: Check drip pan valve to make sure it is completely open while grilling

### **B. IF YOU'RE LOOKING, YOU'RE NOT COOKING!**

Since this grill uses a combination of direct and indirect heat, the lid must be closed at all times.

C. The Holland Grill has no temperature controls. This means the temperature remains constant; it's simply a matter of timing. If the enclosed cookbook doesn't give the time of an item you wish to cook, refer to most any cookbook for that item to find out how much time is recommended at 400 degrees. Remember, you will probably want to turn the food over once at approximately half the cooking time on short cooking time items.

D. The cooking times we suggest are only that - suggestions. You may want to vary the times as you become used to your Holland Grill.

E. You may cook on the grill in any weather. If the temperature is extremely hot or cold, it will slightly shorten or increase your cooking time.

## GRILLING

1. Steak - T-Bone, 1" thick, Medium doneness: Grill 10 minutes on each side.

2. Chicken - Quarters, average size fryer: Cook skin side up for 30 minutes and skin side down for 30 minutes. Check for doneness. If chicken is completely done, only then, dip or

brush on the sauce of your choice. Put back on the grill for approximately 10 minutes longer. NOTE: You may want to repeat this process one or two more times.

3. Pork ribs and chops: 3/4" thick: Grill 10 to 20 minutes on each side. When done, either dip or brush on sauce. Put back on the grill for 5 to 10 minutes longer. Repeat if desired.

## DRY SMOKING

Place Flav-O-Buds or chunks of your favorite dry wood in the aluminum chip tray in your Holland Grill. If additional wood is preferred, you can use throw-away aluminum tart pans in the rear corners of the dry drip pan.

Each bud tray or tart pan can be placed in one or both corners in the space between the top edge of the drip pan and the flange, and the bottom of grill. Refer to diagram.

Each pan will smoke up to an hour, depending on how many chips or chunks you use in each pan. When finished grilling, throw away wood and use fresh each time you grill.

## STEAMING

To steam foods such as oysters, clams, shrimp, crab legs, etc., follow these procedures:

A. Move the grill to location you plan to use it for steaming. The grill should be level.

B. Open lid and close valve on drain pipe. Fill drip pan with water (1 gallon). NOTE: You will speed process by using hot water. CAUTION: Do not attempt to move grill with water in drip pan.

C. Light grill, following lighting instructions.

D. Close lid. In 20-30 minutes, you should see and feel steam coming from the stack. You are ready to begin the steaming process.

E. Put food you wish to steam on grill and close lid. Most shellfish will cook in 15 - to 25 minutes. You may want to cook yours less or more time after checking.

NOTE: Liquid smoke, beer or seasonings such as Brad's Private Stock Seasoning Mix can be added to the hot water to get some seasoning effect.

F. CAUTION: Do not drain water from the grill until it has cooled for at least 30 minutes.

Drain water from pan by placing a large bucket directly under the drain pipe. Open the valve being careful to keep hands away from the water flow. Your grill is now ready to resume regular grilling procedures.

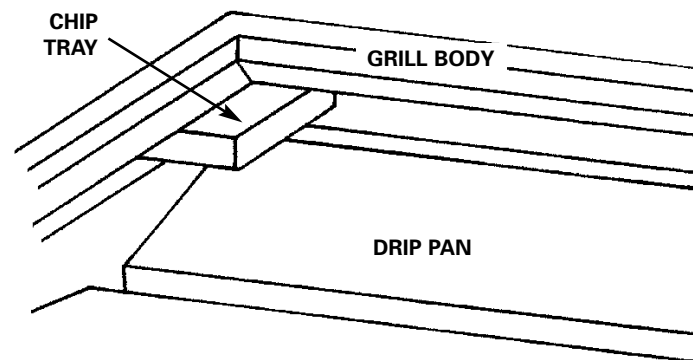

Figure 9

## PARTS LIST FOR BH421 SG-4 TRADITION HOLLAND GRILL

SG5-100	Grill Bottom, Heritage
SG2-201	Stacks, Black (2)
SG5-202	Handle Bracket, Angled, Black
SG2-202A	Handle Spring
SG2-531	Lighting Clip and Chain (Riveted to grill bottom)
SS1-701SS	Black Side Shelf (2)
SG2-1000	Drip Bucket
SG2-702	Shelf Bracket, Right
SG2-703	Shelf Bracket, Left
SG5-200	Grill Top, Heritage
SG2-405	Mid—Brace Left, Notched
SG2-404	Mid—Brace, Right
SG2-403	Axle Brace
SG2-500	Stand Tube
SG2-520	Stand Support Bar, (Front)
SG2-521	Stand Support Bar, (Rear)
SG5-531	Grill Bottom Mount
SG2-800	Tank Retainer
SG2-401	Axle, Classic/Premier/Tradition/ Legacy/Heritage
SG2-400	Wheel (2)
SG2-402	Push Nuts (2)
SG2-510	Stand Foot (2)
SG2-914	Grill Top Stop, Right
SG2-915	Grill Top Stop, Left
SG4-910	Drain Pipe, 3/4" Pipe, 6" Long, Threaded Both Ends
SG4-909	Brass Wheel Valve, 3/4" NPT
SG2-101	Hinges (2)
SG2-300	Grid Cooking Surface, Expanded SS
SG4-600	Drip Pan, with 3/4" NPT Drain

### Fasteners:

**Replacements can be found at most hardware stores.**

SG2-803	Bolts, 1/4-20x5/8"
SG2-804	Nuts, 1/4-20, Hex
SG2-805	Lockwasher, 1/4"
SG2-806	Screw, #10-24 x 1/2, Phillips Lockwasher, #10 Hex Nut #10-24
SG2-807	Wing Bolt (1/4-20x1/2 Carriage Bolt, #10-24 (8) For Shelves
SG4-102	Burner Valve, Angled
SG2-103	Air Shutter (behind Burner Valve)
SG2-104	Insect Screen (Behind Air Shutter)
SG2-105	Burner Assembly (less 102, 103 and 104)
SG2-106	Air Baffle
SG2-107	Flame Deflector Plate
SG2-109	Regulator and Hose Assembly
SG2-100-4	Heat Shield Propane Orifice, drill size 1.30MM Natural Orifice, drill size #48

***If you have a question about the warranty or want to order parts or accessories, please contact your local Holland Grill dealer.***

### Hardware Code

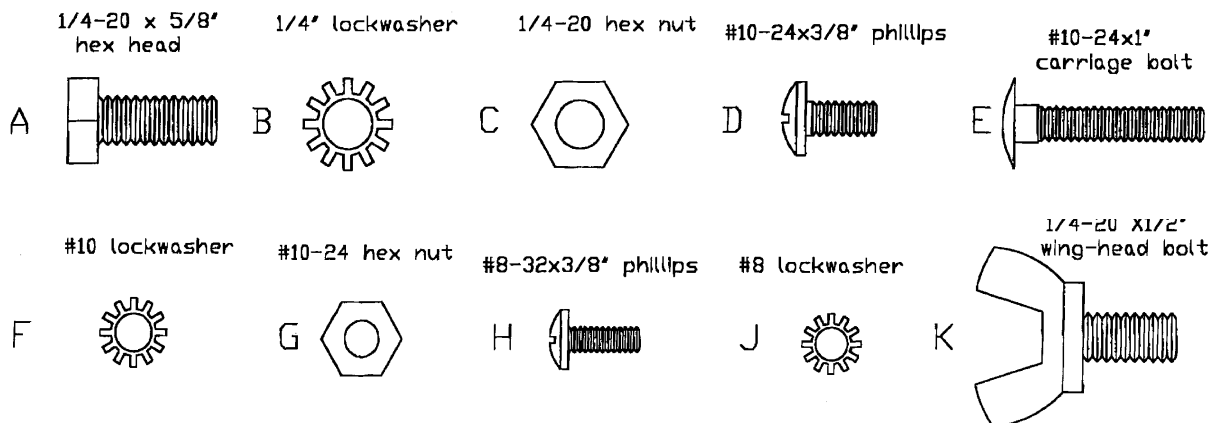

- |  |                             |
|--|-----------------------------|
| A Base Bars, Stand Tube, Shelf Brackets, Bottom Mount, Handle Bracket, Hinges, Lid Stops | H Ignitor Electrode To Body |
| B Base Bars, Stand Tube, Shelf Brackets, Bottom Mount, Handle Bracket, Hinges, Lid Stops | J Ignitor Electrode To Body |
| C Base Bars  | K Tank Retainer             |
| D Stacks   |                             |
| E Shelves To Shelf Brackets  |                             |
| F Stacks, Shelves  |                             |
| G Stacks, Shelves  |                             |

## HOLLAND GRILLING TIME CHART

### **Grilling**

Chicken	3 lb. quartered or halves	40-60 minutes total grilling time
Chicken legs or thighs		45 minutes
Pork Chops	1 inch thick	15 minutes each side
Steak	3/4 - 1 inch thick	9 minutes each side
italian Sausage		40 minutes
Pork Sausage	Patty	8 minutes each side
Pork Ribs		45 minutes
Hamburger	Patty	9 minutes each side
Prime Rib		2 - 2 1/2 hours - use meat thermometer
Pork Roast		Use meat thermometer
Vegetables	All	30-45 minutes total cooking time - best in covered dish
Biscuits	Canned	9 minutes one side & 5 minutes other side

### **Smoking**

Turkey		15 minutes per pound
Fish		20 minutes total

### **Steaming**

Oysters, clams, crab legs, etc.		Approximately 20 minutes
------------------------------------	--	--------------------------

**NOTE:** Remember, the Holland Grill needs to warm up completely. Temperature will remain about 400 degrees. All grilling times approximate depending on size, weight and individual taste preference. Grill needs to remain closed at all times during grilling to be accurate with this time chart. Each time grill is opened during the grilling process, increase grilling time by approximately 10 minutes. A time chart in any cookbook may be of some assistance.

## GRILLING INSTRUCTIONS

**Fish Grilling:** Allow grill to warm up for 15 minutes. Place fish on grill and season to taste. Allow 20-30 minutes total grilling time, turning at half the grilling time if desired (turning is not necessary).

**Fish Smoking:** Make sure grill is where you intend to use it. Close valve on drip pan, and fill with 1 gallon water (hot water speeds up process). Add liquid smoke to water and sprinkle small amount on fish. Light grill. You will feel steam on top of stacks in about 15 minutes, then place fish on grill for approximately 20 minutes. Add seasonings at any time.

**Shellfish:** (oysters, clams, crab legs, etc.): Same as fish smoking, allow 15-30 minutes grilling time.

**Turkey Bar-B-Que:** Allow 15 minutes warm up time. Place turkey on its back in center of grill. Allow 15 minutes grilling time per pound. Not necessary to turn.

**Turkey Smoked:** Follow same procedure as smoking fish. Grill 15 minutes per pound and use meat thermometer to test for doneness.

**Chicken Halves or Quarters:** Place on grill for 60 minutes. Turn at 30 minutes if desired.

**Steak 3/4" - 1" thick:** Allow grill to warm for 15 minutes, then place steaks on grill. Allow 6-10 minutes per side. Ten minutes on each side will produce medium well to well done steaks.

**Hamburger:** Same as steak.

**Ribs:** Allow grill to warm for 15 minutes, place ribs on grill. Allow 40-60 minutes grilling time. Turn at half the grilling time if desired (not necessary). Baste or dip in sauce at any time.

**Roast (pork, beef, lamb, etc.):** Place in center of grill. Pans or aluminum foil are not necessary. Allow 20 minutes per pound grilling time. Use meat thermometer.