

READ THIS

BOOK FIRST



Instruction Manual

The Legacy *LS*

BH421 SS-4

L.P. Tank not included.

L.P. NOTICE: This grill shall be connected only to a 20 lb. L.P. cylinder that is equipped with a Sherwood Valve #PV3349 AND an overfill protection device (OPD).



The only Grill
GUARANTEED
not to flare up!



Dear Friend,

I wish to personally thank you for purchasing one of my Holland Grills. It's my goal that you, your family and friends enjoy your grill for many years to come.

It's important that you are aware that the Holland is unlike any other grill. By design, it allows you to grill or smoke, without the fear of flare-ups commonly associated with competitive brands. Now you can enjoy being with your friends while preparing quality food without the worry and nuisance of trying to control fires.

Not only will you be able to enjoy time with friends while you grill in comfort, you'll be able to do so for years to come. My grill is made of quality materials which give it a sturdiness that will last for years. Unlike other grills on the market, I do not intend for my customers to deal with a long list of replacement parts and the inconvenience of waiting for the parts. This grill was designed and made for your trouble-free outdoor cooking.

Since the Holland does not operate like other grills, it is important to me that you follow all the instructions. I have spent a large portion of my life developing a product that is safe, easy to use and grills to perfection; I personally want to know your comments, questions or any problems that arise from the grill or our field representatives. Please feel free to contact me with your comments, or contact a local dealer who will help you with parts, accessories, literature and warranty.

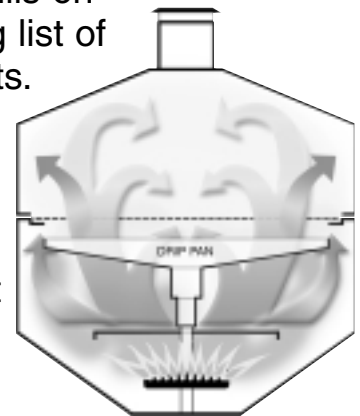

My patented no flare-up design ensures your food can't catch on fire. Simply close the lid and cook by time.

Thank you,

Brad Holland

IT'S IMPORTANT THAT YOU, THE OWNER, READ THE ENTIRE MANUAL BEFORE ASSEMBLING OR USING THE GRILL. IF YOU ALLOW SOMEONE ELSE TO USE YOUR GRILL, MAKE SURE THEY HAVE READ THE INSTRUCTIONS AND UNDERSTAND THEM BEFORE YOU LET THEM OPERATE THE GRILL.

THE LEGACY LS GRILL OWNERS MANUAL

Safety Information

Please read carefully.

FOR YOUR SAFETY

- **IF YOU SMELL GAS:**
 1. SHUT OFF GAS TO THE APPLIANCE.
 2. EXTINGUISH ANY OPEN FLAME.
 3. OPEN LID.
 4. IF ODOR CONTINUES, IMMEDIATELY CALL YOUR GAS SUPPLIER OR FIRE DEPARTMENT.

FOR YOUR SAFETY

1. DO NOT STORE OR USE GASOLINE OR OTHER FLAMMABLE VAPORS AND LIQUIDS IN THE VICINITY OF THIS OR ANY OTHER APPLIANCE.
2. AN LP CYLINDER NOT CONNECTED FOR USE SHALL NOT BE STORED IN THE VICINITY OF THIS OR ANY OTHER APPLIANCE.

- (A) DO NOT STORE A SPARE LP-GAS CYLINDER UNDER OR NEAR THIS APPLIANCE;
(B) NEVER FILL THE CYLINDER BEYOND 80 PERCENT FULL; AND
(C) IF THE INFORMATION IN “-b11(a)” AND “-b11(b)” IS NOT FOLLOWED EXACTLY, A FIRE CAUSING DEATH OR SERIOUS INJURY MAY OCCUR.

- THIS GRILL IS NOT INTENDED TO BE INSTALLED IN OR ON RECREATIONAL VEHICLES AND/OR BOATS.
- THIS GRILL SHALL ONLY BE CONNECTED TO AN LP CYLINDER WITH AN OVERFILL PROTECTION DEVICE (OPD).
- THE GRILL SHOULD BE LIT AND ALLOWED TO OPERATE FOR AT LEAST 30 MINUTES BEFORE USING FOR THE FIRST TIME TO ALLOW PRESERVATIVE TO BURN OFF. AFTER SMOKE STOPS COMING OUT OF STACKS, GRILL IS READY FOR YOUR USE AND ENJOYMENT.
- THIS GRILL IS NOT FOR COMMERCIAL USE
- THIS COOKING APPLIANCE IS FOR OUTDOOR USE ONLY AND SHALL NOT BE USED IN A BUILDING, GARAGE OR ANY OTHER ENCLOSED AREA.
- EXCESSIVELY WINDY OR COLD CONDITIONS MAY AFFECT GRILL COOKING PERFORMANCE.
- CHOOSE ONLY A LEVEL LOCATION FOR GRILL OPERATION. THE HOLLAND GRILL MUST BE SITTING SECURELY ON A LEVEL SURFACE FOR PROPER OPERATION AND EVEN HEAT DISTRIBUTION.
- YOUR GRILL IS MADE FOR OUTDOOR USE ONLY
- THE VENT STACKS AND THE AIR INTAKE OPENINGS SHOULD NEVER BE BLOCKED OR CLOSED DURING GRILL OPERATION.
- MINIMUM CLEARANCE FROM SIDES AND BACK OF UNIT TO COMBUSTIBLE CONSTRUCTION, 18 INCHES (50CM) FROM SIDES AND 18 INCHES (50CM) FROM BACK.
- DO NOT USE THIS OUTDOOR APPLIANCE UNDER OVERHEAD COMBUSTIBLE SURFACES.
- DO NOT STORE A SPARE LP GAS CYLINDER UNDER OR NEAR THIS APPLIANCE.

WARNING: FOLLOW LOCAL CODES

- THE INSTALLATION OF THIS APPLIANCE MUST CONFORM WITH LOCAL CODES OR IN THE ABSENCE OF LOCAL CODES, CONFORM TO THE NATIONAL FUEL GAS CODE ANSI Z223.1./NFPA 54
- INSTALLATION SHALL BE IN ACCORDANCE WITH CAN/CGAB149.1 NATURAL GAS AND PROPANE INSTALLATION CODE AND LOCAL CODES WHERE APPLICABLE.

The Fuel System

Gas grills are used SAFELY by millions of people when following simple SAFETY precautions.

The items in the fuel system are designed for operation with the Holland Grill. They must not be replaced with any other brand. (See parts list for replacement items.)

GAS BURNER: The gas burner is constructed of heavy cast iron and should not require maintenance other than inspection for insect nests inside the venturi. If you remove the burner for cleaning, it must be reinstalled exactly as removed.

Air shutter: See item 11 in lighting instructions on page L-7 (see figure 6 for details.)

BURNER VALVE: The burner valve is operated in only two positions. The Off position is when the knob bar is Horizontal, the pointer is at the OFF mark. This stops the flow of gas. When the valve has been set in the OFF position, it is important to also close the valve on the LP tank or Natural gas supply. The On position is when the knob bar pointer is straight up, at the ON/LIGHT position. The burner valve controls the heat allowed in the grill by means of a plug orifice. This device is set at the factory and must not be tampered with. See Lighting instructions on page L-7 for more information. Turn off LP supply at cylinder when appliance is not in use.

ONLY A FACTORY SUPPLIED VALVE SHOULD BE USED. (See the parts list for replacement items.)

LP GAS HOSE: The LP gas hose is designed for use with LP gas only. Use with any other gas is dangerous. The hose is made of a flexible material to make it easy to install. This material is subject to considerable twisting and turning during installation. It is very important that the hose be inspected for cracks, cuts, abrasions, wear and loose fittings. The visual inspection should include leak testing the entire length of hose and fittings. (See final assembly instructions for more information.)

If the hose shows signs of damage or leakage, it must be replaced prior to the operation of the grill. Only a factory authorized replacement part can be used. (See the parts list for replacement items.) Failure to properly inspect or replace hose with an authorized replacement may result in accident or injury.

LP GAS REGULATOR: CAUTION: Use only the gas pressure regulator supplied with this appliance. This regulator is set for an outlet pressure of 11 inches water column. Substitution of regulator by any other device or any other manufacturer's regulator is dangerous and could result in serious injury. (See the parts list for replacement items.)

PROPANE FUEL: Warning – propane is a flammable gas. Improper handling may result in an explosion and/or fire and seri-



ous accident or injury. Your grill is designed to operate on Propane (LP) gas ONLY and is equipped with the proper orifice for this gas. Caution: Do not connect this grill to any gas supply except propane or natural gas. Propane gas is heavier than air and will settle in low areas. Make certain adequate ventilation is available when using your grill and that the gas cylinder is stored outside in a well ventilated area out of the reach of children when the grill is not in use.

LP GAS CYLINDER: This grill is designed and intended to be used with an LP gas cylinder with a nominal LP gas capacity of 20 pounds. Such a cylinder is approximately 12-3/8" in diameter with an overall height of 18-1/16". The Holland Grill does not come with an LP gas cylinder. This must be purchased separately and is available at most hardware stores. The cylinder used must be constructed and marked in accordance with the specifications for LP gas cylinders of the U.S. Department of Transportation (DOT) (4BA-240) and the National Standard of Canada CAN/CSA-B339, cylinders, spheres, and tubes for the transportation of dangerous goods. Only a cylinder equipped with an overfill protection device (OPD) should be used.

The LP gas cylinder shall be used only outdoors in a well ventilated space and not in a building, garage, or any other enclosed area. The LP gas cylinder is designed to be used, stored, and transported in the upright position. The Holland Grill may be stored indoors if the LP gas cylinder is removed and stored outdoors. NEVER turn the cylinder upside down or on its side. Always transport, store and use your cylinder in the upright position.

The cylinder must be provided with a Sherwood valve, part #PV3349, which will connect with (quick connect) the QCC-1 Fitting provided on each of our LP (propane) grills. Must also have a safety relief device having a direct communication with the vapor space of the cylinder. The cylinder supply system must be arranged for vapor withdraw. The cylinder shall include a collar to protect the cylinder valve. The grill must be connected to the gas supply by a hose. Turn off LP supply at cylinder when appliance is not in use.

DO NOT transport a full or empty gas cylinder in a closed automobile trunk or in a closed passenger area.

Filling the gas cylinder requires removing it from the grill. The cylinder is attached to the grill by connecting the regulator assembly to the inlet portion of the gas cylinder valve. This connection is made by the QCC-1 fitting pictured in Figure 1-A. The large plastic nut fits on the outside of the threads and turns right, or clockwise to tighten. No tools are necessary. Hand tight is sufficient. If a good connection is not achieved, the safety valve inside will not permit the proper amount of gas to flow. When connecting the regulator to the cylinder valve, be sure the pressure relief valve is directed away from the front and away from the grill. If the relief valve should open, the propane will be directed where it is likely to do the least harm. To disconnect regulator assembly turn large plastic nut left or counter-clockwise.

When disconnecting and connecting the gas cylinder, be careful that

the regulator assembly does not strike the grill, the ground, or any other surface. If any difficulty at all is had in connecting or disconnecting the regulator assembly to the cylinder valve, contact your local gas supplier for assistance.

When disconnected from the cylinder, a valve cap must be installed. (See figure 1-A.) Failure to install a valve cap when the cylinder is disconnected from the fuel system is dangerous and may result in accident or injury.

When re-connecting the LP gas cylinder, be sure to tighten the fitting until snug. This connection, as well as all other fittings and connections between the cylinder and burner valve, should be inspected for damage and leak tested after every filling or re-connection.

Keep any electrical supply cord and fuel supply hose away from any heated surface.

NATURAL GAS: If natural gas is used, contact your local supplier to set it up properly. The N.G. Holland Grill is set to operate at 7 inches water column pressure, using an orifice with a #48 (NAT) drill size. If your grill seems too hot, first call your local gas company to determine what pressure you have.

Never allow anyone to change orifice size without authorization from factory.

SPARK IGNITOR: This grill is equipped with a rotary Piezo ignitor system. A simple Clockwise rotation of the ignitor knob produces a spark at the burner head, lighting the burner. To check that the spark ignitor is working properly, leave gas supply turned OFF and observe the spark by looking through the peep hole above the control panel or from below the control panel to the left side of the burner in the burner opening. A small blue spark should be visible at the left side of the burner head every time the ignitor "fires". A loud "hammer" like sound is produced by the mechanism when sparking.

FIGURE 1

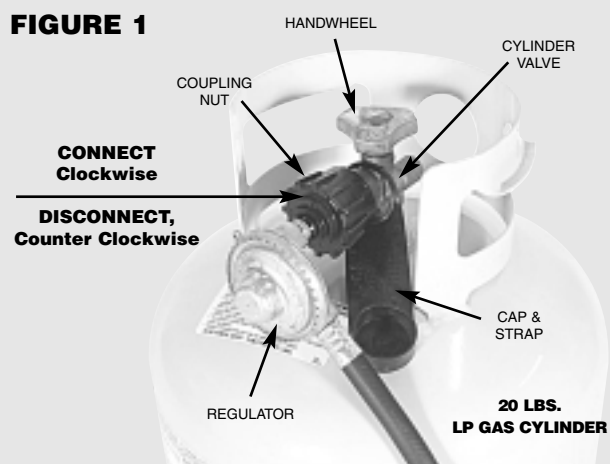

LEGACY LS ASSEMBLY INSTRUCTIONS

MODEL BH421SS-4 Legacy LS



Tools needed for assembly:

1. Phillips screwdriver
2. 3/8" & 7/16" nut driver
3. 7/16" & 1/2" wrench

Note:
Use one lock washer per bolt, either under the hex nut or under the bolt head if a hex nut is not used.



A 8, #10-24 x 3/8" Phillips Head (used for grill stacks)



B 20, #10-24 Hex Nut



C 21, #10 Lock washer



D 8, #10-24x1" Carriage Bolt (used for molded side shelves)



F 22, 1/4 - 20 x 3/4" Bolt



G 32, 1/4" Lock washer



H 6, 1/4" Hex nut



I, J, K 3, #5-40 screw, lock washer & nut



L 2, 10 x 3/8" Truss Head Utensil holder screw



M 4, #10-24x1/2" Carriage Bolt



N 1, #8-32x3/8" Machine screw



O 2, 1/4 x 3/4" Round Head Phillips (used for grill handle)

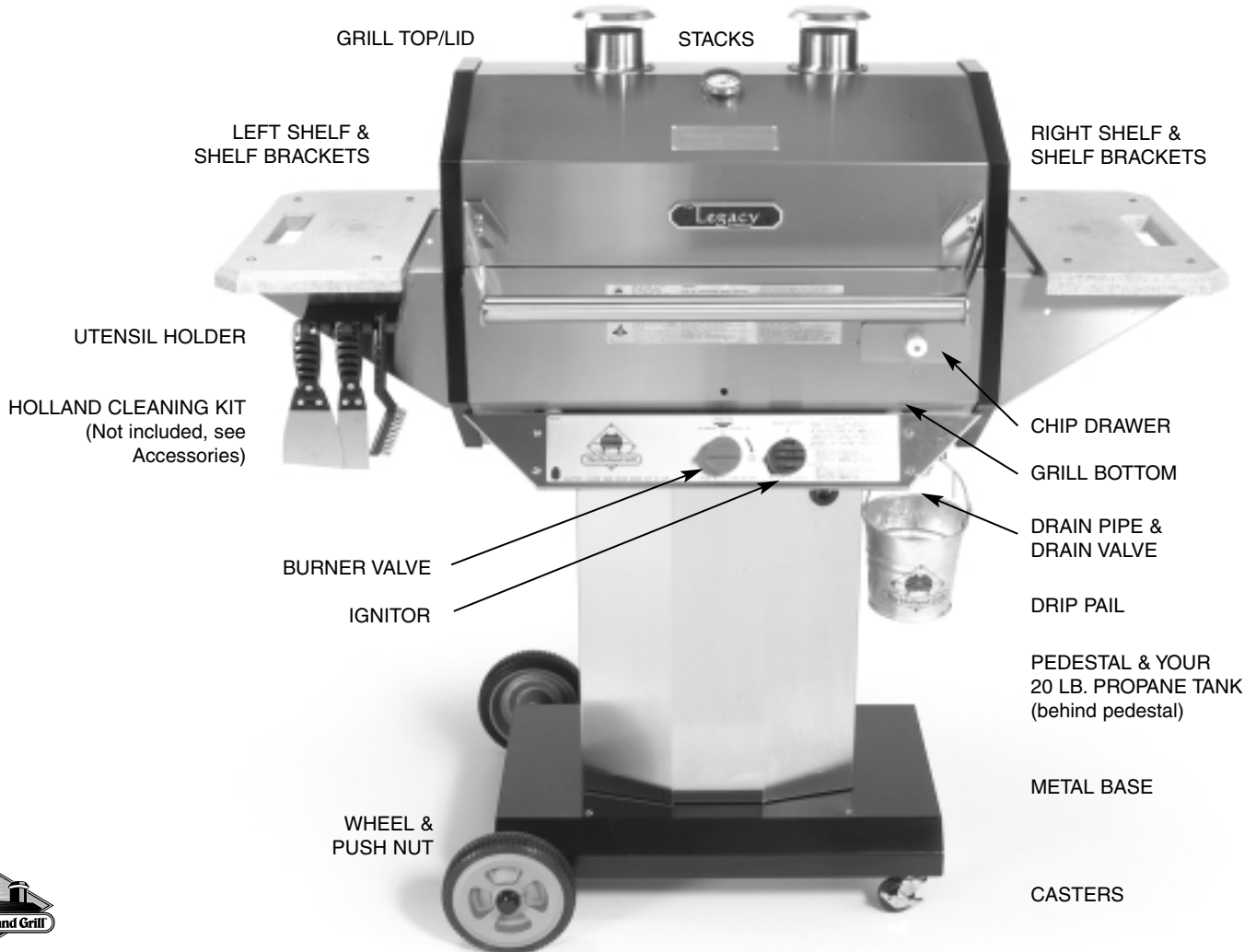

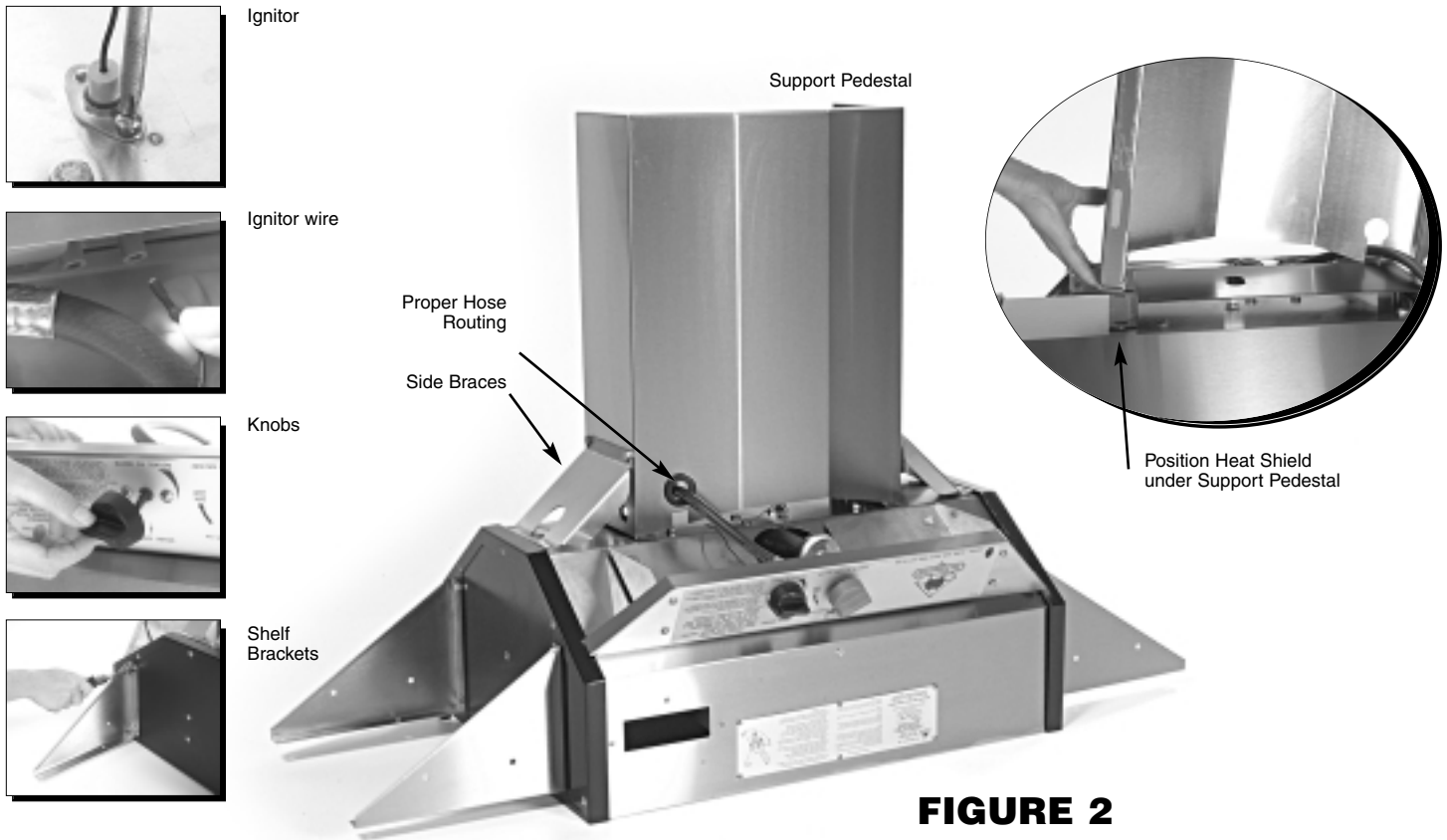

FIGURE 2

Step 1.

On a flat surface (table or carport floor), OPEN AND EMPTY BOTH BOXES. REFER TO THE CONTENTS LIST ON PAGE T-13 TO BE SURE NO PARTS ARE MISSING. Tighten all factory installed fasteners that may have loosened during shipping.

Step 2.

Refer to **Figure 2**. Select the following items:

- | | |
|--------------------------|---------------------|
| 1. Grill Bottom Assembly | 5. Support Pedestal |
| 2. Ignitor Electrode | 6. Shelf Brackets |
| 3. Heat Shield | 7. Control Knobs |
| 4. Side Braces | |
- Install the **Ignitor Electrode** into the grill bottom as shown using a #8-32 “N” screw to secure it in place.
 - Push the loose end of the electrode wire onto the terminal on the rear of the Ignitor body behind the control panel.
 - Position the **Support Pedestal** end with 4 holes onto the grill bottom, guiding the regulator hose through the keyhole slot in pedestal
 - Slide the **Heat Shield** into position under the Support Pedestal and align the ignitor clearance hole with the ignitor
 - Line up the 4 holes of the Grill Bottom, Heat Shield and Support Pedestal. Secure with 4, 1/4-20x3/4” “F” bolts and lock washers “G”
 - Position the **Rubber Grommet** on the hose into the keyhole in the Support Pedestal
 - Attach the **Side Braces** using 8, 1/4-20x3/4” “F” bolts, 8 lock washers “G” and 4, 1/4-20 hex nuts “H”
 - Attach 4 **Shelf Brackets** using 8, 1/4-20x3/4” bolts “F”, 8 lock washers “G”

*At this point you should check to see that the **Spark Ignitor** is working properly. Locate the Ignitor knob, if not already in place, (the knob WITHOUT the Holland logo) push it firmly into place on the rotary ignitor shaft sticking through the control panel. Rotate the knob **CLOCKWISE** and observe the electrode tip inside the grill body next to the burner head. You should see a small blue spark upon every actuation of the spark mechanism.*



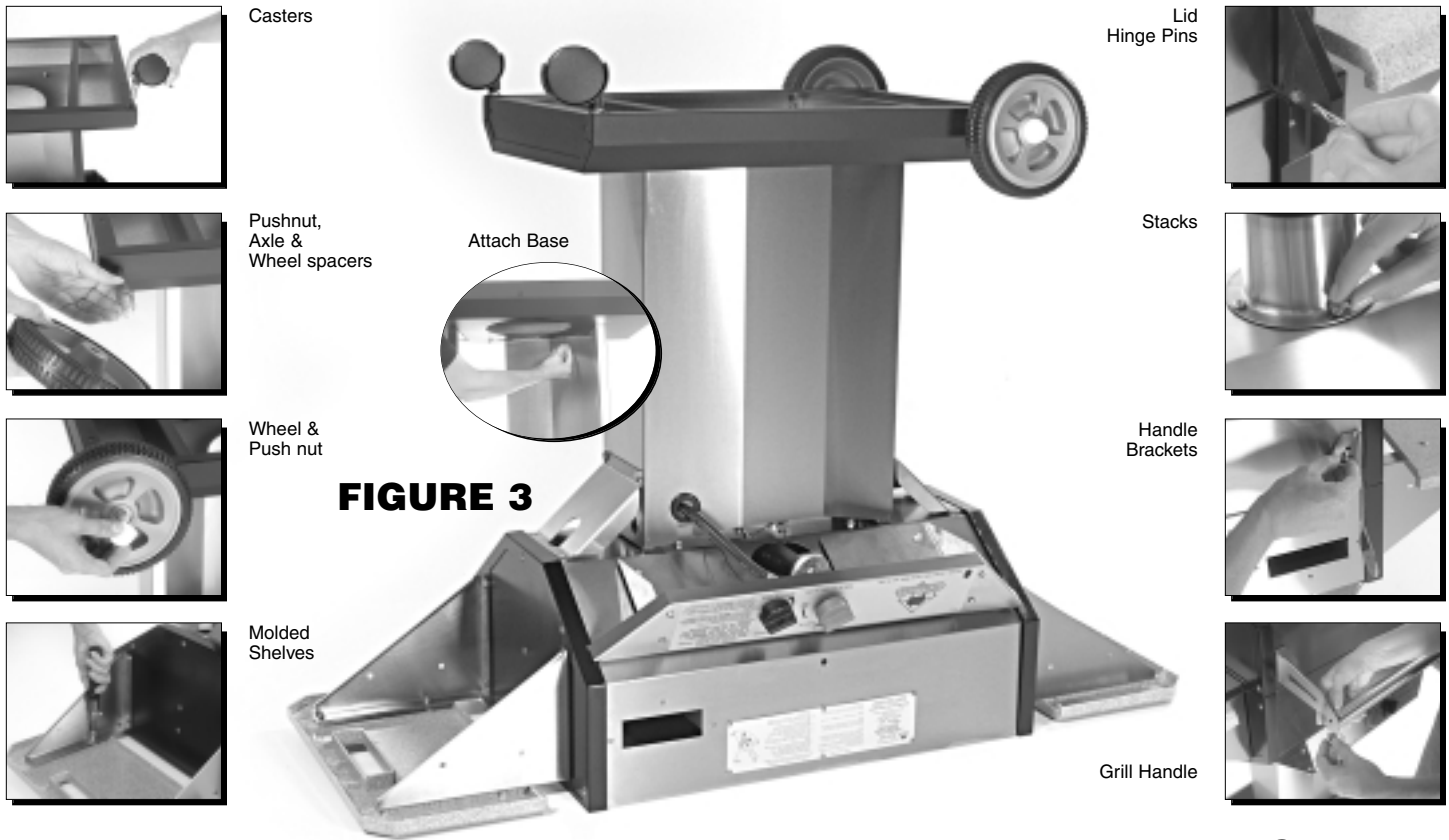

FIGURE 3

FIGURE 4

Step 3.

Refer to **Figure 3**. Select the following items:

- | | |
|---------------|--------------------|
| 8. Metal base | 12. Wheel Spacers |
| 9. Casters | 13. Push Nuts |
| 10. Axle | 14. Molded Shelves |
| 11. Wheels | |

- Set the **Metal Base** on the inverted Support Pedestal, matching up the mounting holes. Use 8, 1/4-20x3/4" "F" bolts and 8 "G" lock washers to secure
- Insert the **Castors** into the caster sockets and push until completely seated
- Tap one of the **Axle Push Nuts** onto the end of the **Axle** using a hammer. Place one of the **Wheels** onto the axle followed by one of the grey **Axle Spacers**. Insert the axle through the molded base. Place the remaining axle spacer and wheel onto the axle and tap the remaining push nut onto the axle
- Attach the **Molded Shelves** to the shelf brackets using 8, #10-24x1" "D" carriage bolts, 8, #10 lock washers "C" & 8, 10-24 hex nuts "B"
- **Now turn entire grill/base assembly over onto its wheels**

Step 4.

Refer to **Figure 4**. Select the following items:

- | |
|-----------------------------|
| 15. Grill top |
| 16. Grill Handle & brackets |
| 17. Stacks (2) |

- Place the **Grill Top** squarely on grill bottom. Insert pin through hinge holes in back and secure with hairpin clip
- Select the two **Stacks** and attach them to the grill lid with 8, #10 - 24 x 3/8" "A, C, B" bolts, lock washers and hex nuts
- Install the **Thermometer** through the small hole in the center of the lid near the stacks. Use a 1/2" wrench to tighten the thermometer securing nut
- Select the two **Handle brackets** and attach them to the grill lid using 4, #10 - 24x1/2 "M, C, B" carriage bolts, lock washers and hex nuts
- Secure the **Handle** to the handle brackets with 2, 1/4 - 20 x 3/4" "O" phillips head screws



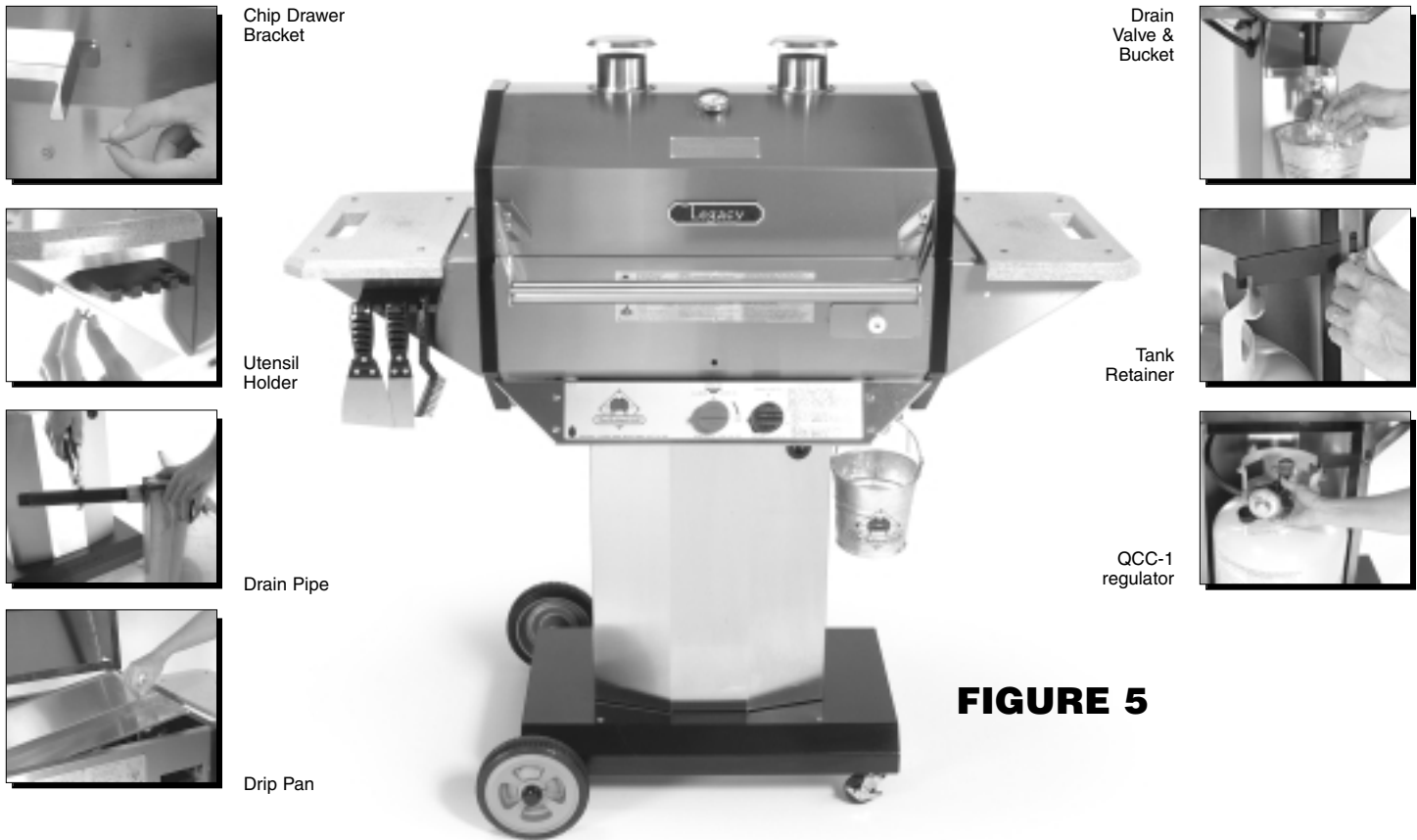

FIGURE 5

Step 5.

Refer to **Figure 5**. Select the following items:

- | | |
|-----------------------|-------------------------|
| 18. Chip Drawer guide | 21. Brass wheel valve |
| 19. Drip pan | 22. L.P. Tank top brace |
| 20. Drain Pipe | 23. Utensil Holder |

- Open the grill lid. Install the **Chip Drawer Guide** into the right front corner of the grill body using 3, #5-40 bolts “I, J, K”, lock washers and nuts
- The **Utensil Holder** attaches to a shelf bracket with (2) “L” screws. It may be installed on either side
- Install the short length of **Drain Pipe** in the female threaded coupling in the right end of the drip pan. Tighten with pliers or pipe wrench
- Place the **Drip Pan** into the grill bottom using the lift tabs at each end as handles. Line up the drainpipe with the hole in the grill bottom and body support bracket, making sure pipe extends out bottom and drip pan is sitting level in its brackets
- Install the **Brass Drain Valve** by threading it onto the end of the drain pipe extending from the bottom of the grill. Hand tight is sufficient. Hang drip pail on the drain Valve

Tank Installation

- Place your full 20-lb. propane tank into the hole of the grill base. Install the **Tank Hold -Down Bracket** using the wing nut and adjust to secure the tank. You may need to rotate the tank to find a suitable area for the Hold Down Bracket to engage.
- Screw the **QCC-1 regulator** onto the propane tank valve by hand. The large plastic nut fits over the outside of the tank valve threads and turns right, or clockwise, to tighten. No tools are needed.
- If a good connection is not achieved, the safety valve inside the QCC-1 regulator will not permit the proper amount of gas to flow. The only way to know if the proper amount of gas is getting to the burner is by looking at the flame once the grill is lit. If the flame looks very small, simply unscrew the regulator, wait a few minutes and re-attach. This will re-set the QCC-1 safety valve.
- Check all bolts and nuts for tightness and proceed to gas leak testing.

SOAPY WATER TEST

In a small bowl mix half liquid detergent and half water. Turn on propane tank valve. Using a small brush, soap all connections from tank to grill and look for bubbles. Correct all leaks before proceeding. Turn off propane tank valve.

NOTE: The Holland Grill uses a 2-position gas valve on the burner control. The illustration (Figure 6) shows the handle in the OFF position. To turn ON push the handle to the right and outward in direction of the arrow (counter-clockwise) for its full travel (about 90 degrees). NEVER operate the Holland Grill with the handle in any intermediate position.

FOR NATURAL GAS SUPPLY

The Holland Grill, including the gas off-on valve, must be disconnected from the gas supply during any pressure testing of that system, at test pressures in excess of 1/2 psig.

The Holland Grill must be isolated from the gas supply piping system by closing the individual manual shut-off valve during any pressure testing of the gas supply piping system at test pressure equal to or less than 1/2 psig.

**FIGURE 6
CUTAWAY VIEW**

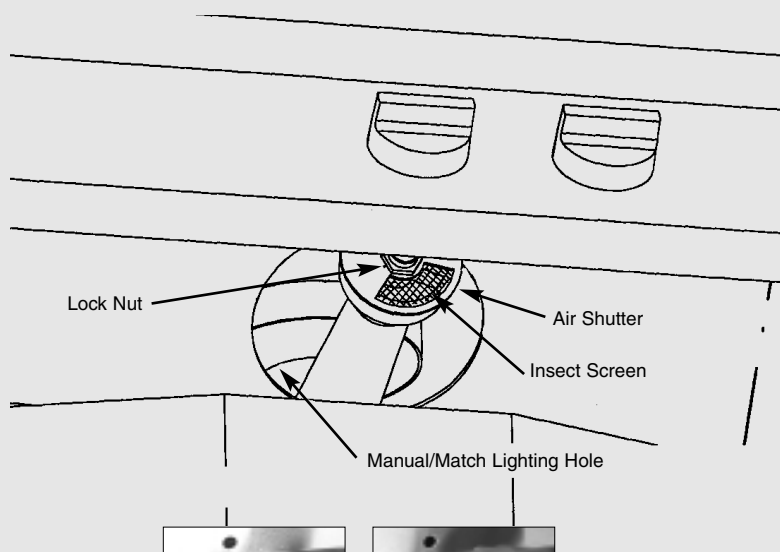

Closed (OFF)



Open/Light (ON)

LIGHTING INSTRUCTIONS

Refer to *Figure 6*.

1. Make sure the propane tank valve and the burner valve are both fully off.
2. Open the grill lid and allow five full minutes to air out.
3. During this time, inspect the gas system for damaged hose or loose fittings. Check the hose for wear, abrasions, cuts or kinks. If any damage is found, replace hose using only factory-approved replacement hose. Never attempt to light this or any gas grill with a cracked, split, braided, or severely kinked hose or with any broken or leaking fittings.

SPARK IGNITOR LIGHTING

4. Open valve at propane tank or natural gas supply
5. Turn the valve 90 degrees counter-clockwise to the ON position.
6. IMMEDIATELY TURN THE SPARK IGNITOR KNOB RAPIDLY, UP TO 5 TIMES.
7. If ignition does not occur in 5 seconds, turn the burner control(s) off, wait 5 minutes, and repeat the lighting procedure.

MANUAL/MATCH LIGHTING

8. Open valve at propane tank or natural gas supply. Insert match or lighter into left side of burner hole opening, next to burner, up under control panel, with flame next to burner head.
9. Turn valve knob to ON position. If ignition does not occur in 5 seconds, turn the burner control(s) off, wait 5 minutes, and repeat the lighting procedure.
10. When the burner lights remove the match or lighter.

ADJUSTING AIR SHUTTER

11. Loosen the lock nut with a 5/8" open end wrench so you can turn the air shutter. Adjust the flame by turning the air shutter on the face of the burner valve slowly. When most of the orange color has left the flame, and it has become uniformly pale yellow-to-blue, the flame is properly set. There should be no need for re-adjustment for the life of your Holland Grill, but it is wise to check the flame color each time you light your grill. Lock nut should be tight against valve.

Make sure while looking to adjust or check flame to use the peep hole just above valve. See below: The flame should be blue in color.

NOTE: Some yellow tipping may occur. It's not unusual and will not affect the performance of the grill.

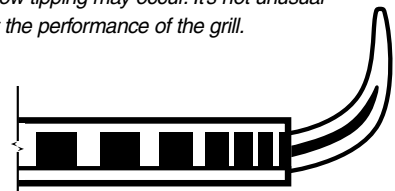

PROPER AIR SHUTTER SETTING

12. After air shutter adjustment, your grill is ready for use – proceed to COOKING INSTRUCTIONS.
13. If the burner did not light properly, wait 5 minutes before attempting re-light, then repeat steps 1-9.
14. If the grill fails to light after the second attempt, call your local LP gas dealer for professional assistance.
15. With the burner lit, gently close the lid and allow the grill to warm for 20-30 minutes.

NOTE: If for any reason the burner should go out, shut off gas at the burner and the LP cylinder. DO NOT attempt to re-light without repeating steps 2-9.



TURNING GRILL OFF

1. Open lid
2. Turn burner valve knob to OFF position
3. Turn off LP supply at cylinder when appliance is not in use.
4. CAUTION: Do not attempt to relight without following all lighting instructions.

IMPORTANT: Always shut off the burner valve before closing the tank/gas supply valve. This grill is equipped with a QCC-1 flow-limiting connector which will not reset to allow full gas flow if the supply valve is closed before the burner valve is shut off. If you experience trouble with the grill not heating properly, shut off burner valve, then tank or supply valve. Open lid, wait 5 minutes and follow lighting instructions.

CARE AND MAINTENANCE

There is very little care and maintenance needed. The Holland Grill is designed and made of materials that will last many years with normal use. Following these instructions will improve the longevity and quality of cooking. To assure safe operation of your Holland Grill, the area for cooking should always be kept free of combustible materials of any type, such as gasoline or other flammable vapors or liquids.

Outside of body: This is aluminum and stainless steel and can be cleaned easily with warm soapy water or mild cleaner. If paint gets scratched, remove grease and repaint with a heat resistant paint. The aluminum surface will last longer. Do not use wire brushes, scrapers or abrasive cleaners for normal cleaning.

Grid and Drip Pan: The grid is made of high quality stainless steel. The grid should be brushed with a brass, copper, or stainless steel brush immediately after removing food while grill is still warm. The drip pan is aluminum and can be cleaned with a flat scraper such as a putty knife. CAUTION: The drip pan must be kept clean and free of heavy build-up for grill to perform properly, and to eliminate flare-ups. Do not wash drip pan.

Inside Grill: Use warm soapy water to clean this area. Do not allow grease to build up.

Drain Pipe and Valve: Both must be kept clear of grease and food particles to allow grease to drain properly from drip pan. This must be done to maintain proper operation of your grill.

Side Shelves: These are made from high quality thermoset material designed for long outdoor life. Warm soapy water can be used for cleaning. CAUTION: Do not use shelves as a chopping block, nor should more than 15 pounds be placed on them at any time.

General: This grill, like all equipment, will look better and last longer if kept out of weather when not in use. CAUTION: Do not store gas tank in closed areas. See instructions or local gas ordinances for care and storage of propane tanks. When using a cover, never place it on the grill until the entire unit has cooled at least 30 minutes.

- Check to be sure all openings into the grill body are free of blockages or debris. Make sure there are no objects or materials blocking the flow of combustion and ventilation air.
- Turn off LP supply at cylinder when appliance is not in use.

- For outdoor use only. If stored indoors, detach cylinder and leave it outdoors.
- Cylinders must be stored outdoors out of reach of children and must not be stored in a building, garage or any other enclosed area.
- Check burner venturi behind air shutter screen for insect nests or blockages. Make sure the passage through the burner venturi is not obstructed. A clogged tube can lead to a fire beneath the grill.

Location of the valve to the Burner: If the burner valve is ever removed for cleaning or replacement, it should be re-installed to the dimension shown below. Measure from the center of the valve handle to the face of the burner air shutter. This assures correct positioning of the orifice in the burner venturi.

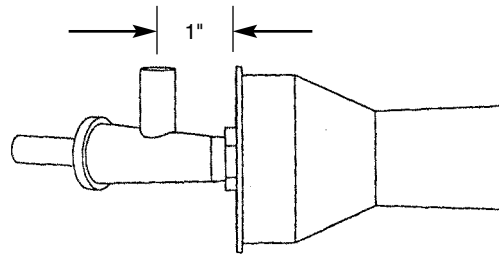

IMPORTANT - FIRST TIME USE: It is important that the grill be lit and allowed to operate at least 30 minutes before any food is placed on the grill grid. Some smoke may appear during this period. This is the preservative used during manufacturing. After initial heating, the grill is ready for use. After burning off the grill, spray the food grid, drip pan and the inside of the lid with PAM or similar spray, so food does not stick to the grid and the inside is easier to clean.

MOVING INSTRUCTIONS

CAUTION: NEVER MOVE GRILL WITH BURNER LIT OR WITH WATER IN DRIP PAN.

Moving in your yard or deck: Make sure gas is turned off at burner valve and tank valve. Be sure lid is closed. Lift by the shelf on the end with casters. Push your grill to desired location, first checking for holes or obstacles that may cause tripping or falling. Make sure grill is level before using. Set locks on casters.

Moving on trailer or truck: Follow all steps above. Before loading, secure lid closed by tying rope or bungee cord from handle to the base. After loading, be sure to tie down securely to prevent damage.

NEVER transport your grill with propane tank connected. CAUTION: Always secure propane tank tightly to truck or trailer.

COOKING INSTRUCTIONS

ALLOW GRILL TO WARM UP WITH LID CLOSED FOR 20 - 30 MINUTES PRIOR TO COOKING.



- It is important to realize cooking on a Holland Grill uses a different process in order for the grill to perform correctly. It is essential that the lid remain closed while grilling.

NOTE: Check drip pan valve to make sure it is completely open while grilling

• **IF YOU'RE LOOKING, YOU'RE NOT COOKING!**

Since this grill uses a combination of direct and indirect heat, the lid must be closed at all times.

- The Holland Grill has no temperature controls. This means the temperature remains constant; it's simply a matter of timing. If the enclosed cookbook doesn't give the time of an item you wish to cook, refer to most any cookbook for that item to find out how much time is recommended at 400 degrees. Remember, you will probably want to turn the food over once at approximately half the cooking time on short cooking time items.
- The cooking times we suggest are only that -- suggestions. You may want to vary the times as you become used to your Holland Grill.
- You may cook on the grill in any weather. If the temperature is extremely hot or cold, it will slightly shorten or increase your cooking time.

GRILLING

Steak -- T-Bone: 1" thick, Medium doneness: Grill 10 minutes on each side.

Chicken, Quarters, average size fryer: Cook skin side up for 30 minutes and skin side down for 30 minutes. Check for doneness. If chicken is completely done, only then, dip or brush on the sauce of your choice. Put back on the grill for approximately 10 minutes longer.

NOTE: You may want to repeat this process one or two more times.

Pork ribs and chops, 3/4" thick: Grill 10 to 20 minutes on each side. When done, either dip or brush on sauce. Put back on the grill for 5 to 10 minutes longer. Repeat if desired.

SEE PAGE L-11 FOR MORE COOKING IDEAS

DRY SMOKING

Place Flav-O-Buds or chunks of your favorite dry wood in the stainless steel chip drawer in the grill front. If additional wood is preferred, you

can use throw-away aluminum tart pans in the rear corners of the dry drip pan.

Each pan will smoke up to an hour, depending on how many chips or chunks you use in each pan. When finished grilling, throw away wood and use fresh each time you grill.



STEAMING

To steam foods such as oysters, clams, shrimp, crab legs, etc., follow these procedures:

1. Move the grill to location you plan to use it for steaming. The grill should be level.
2. Following lighting instructions, light your grill and preheat it for 30 minutes and then fill drip pan with 1 gallon of **hot** water.
3. Close lid. In 20-30 minutes, you should see and feel steam coming from the stack. You are ready to begin the steaming process.
4. Put food you wish to steam on grill and close lid. Most shellfish will cook in 15 - to 25 minutes. You may want to cook yours less or more time after checking.

NOTE: Liquid smoke, beer or seasonings such as Brad's Private Stock Seasoning Mix can be added to the hot water to get some seasoning effect.

CAUTION: Do not drain water from the grill until it has cooled for at least 30 minutes.

Drain water from pan by placing a large bucket directly under the drain pipe. Open the valve being careful to keep hands away from the water flow. Your grill is now ready to resume regular grilling procedures.



HOLLAND LEGACY LS REPLACEMENT PARTS

Model BH421 SS-4

The Holland Legacy LS parts are made from aluminum and stainless steel.

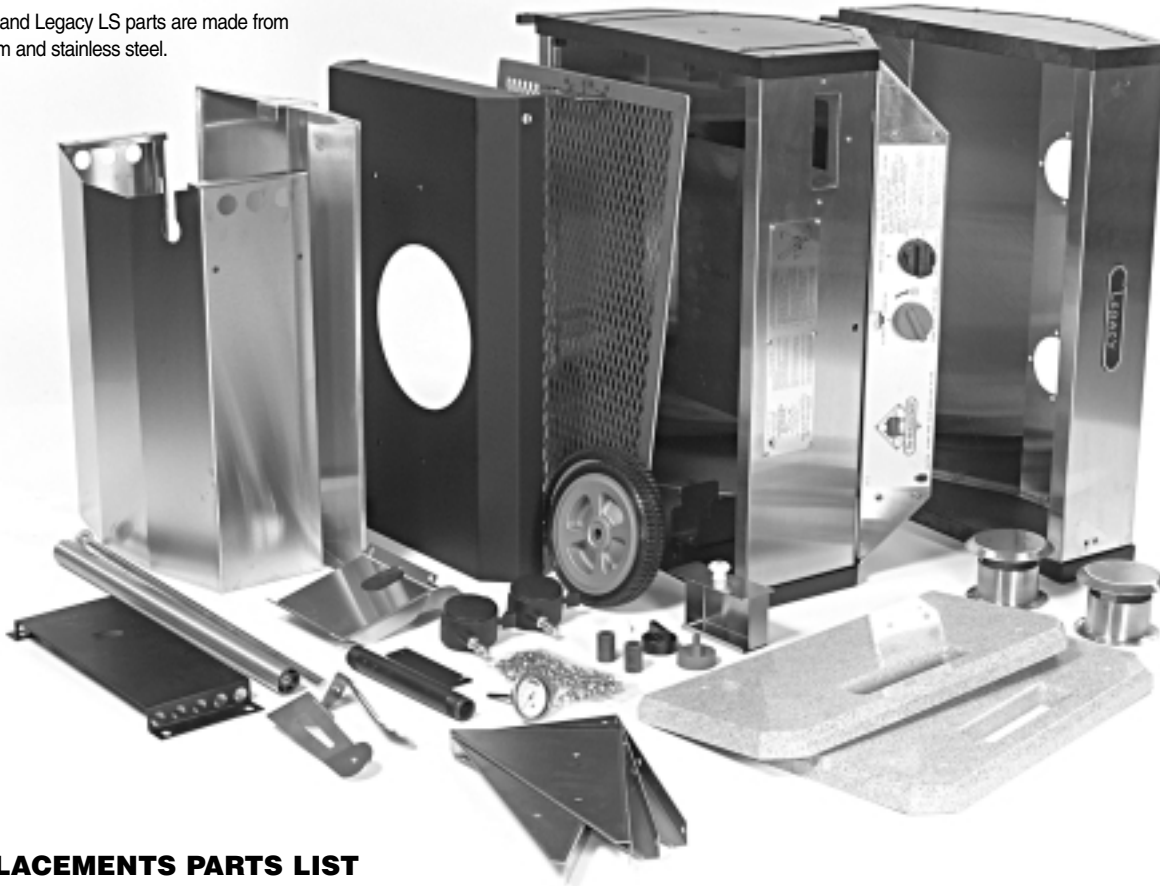

REPLACEMENTS PARTS LIST

Stock No.	Description
SS4-100	Grill bottom, Legacy LS, SS w/alum ends
SS2-201	Stacks, SS, short version (2 req'd)
SS3-251L	Handle bracket, left, SS
SS3-251R	Handle bracket, right, SS
SS3-250	Handle tube, SS, with inserts
SG4-701	Shelf, gray, NuStone
SG2-1000	Drip bucket
SS2-702SS	Shelf bracket, RF/LR, SS (2 req'd)
SS2-703SS	Shelf bracket, LF/RR, SS (2 req'd)
SS4-200	Lid assembly, Legacy LS, SS w/alum ends
AG2-300	Cooking grid, SS mesh, wide band
SS4-500	Support pillar, SS
AG3-550	Metal base assembly, black
SS4-559	Side body braces, Tradition LS (2 req'd)
AG2-107	Flame deflector plate, SS, BH421 grills
SG2-401	Axle, Heritage, Tradition, Legacy, Tribute
AG2-400	Wheel, DeLuxe, BH421 Series (2)
AG3-450	Axle spacer (2 required)
AG2-402	Push nut, black (2)
AG3-850	Tank retainer, Tradition/Legacy LS
SS3-155	Control panel, SS
SS3-170	Control panel bracket, SS
SG4-151	Insulator, control panel bracket (4)
AG2-910	Drain pipe, 3/4"
SG4-909	Brass drain valve, Holland
AG2-600	Drip pan, aluminum, 3/4" drain
SG2-532	Lighting clip and chain

Stock No.	(QT.)	Description
Fasteners:		
G	(32)	1/4 External Tooth lock Washer
H	(6)	1/4 - 20 Hex Nut, SS
F	(24)	1/4 - 20 x 3/4" Hex Cap Screw, SS
O	(2)	1/4 - 20 x 3/4" Round Head Phillips M/S, SS
B	(20)	10 - 24 Hex Nut, SS
M	(4)	10 - 24 x 1/2" Carriage Bolt, SS
D	(8)	10 - 24 x 1" Carriage Bolt, SS
A	(8)	10 - 24 x 3/8" Pan Hd Phillips Machine Screw, SS
N	(1)	8 - 32 x 3/8" Pan Hd Phillips Machine Screw, SS
C	(21)	#10 External Tooth lock Washer
L	(2)	#10 x 3/8" Truss Hd Phillips, Type "A", SS
I	(3)	#5 - 40 x 3/8" Pan Hd Phillips, Machine Screw, SS
J	(3)	#5 - 40 Hex Nut, SS
K	(3)	#5 Split Lock Washer, SS
	(1)	5/16" Hex Nut, SS (included with Thermometer)
SG2-807		Wing Bolt 1/4-20x1/2

The following parts are factory installed in 100 Grill Bottom, but may be ordered individually:

SG4-102	Burner Valve, Angled
SG2-103	Air Shutter (behind Burner Valve)
SG2-104	Insect Screen (Behind Air Shutter)
SG2-105	Burner Assembly (less 102, 103 and 104)
SG2-106	Air Baffle
AG2-107	Flame Deflector Plate, SS, BH421 grills
SG2-109	Regulator and Hose Assembly
SG2-110	Propane Orifice, drill size #55
SG2-116	Natural Gas Orifice, drill size #48

If you have a question about the warranty or want to order parts or accessories, please contact your local Holland Grill dealer.





HOLLAND GRILLING TIME CHART

Grilling

Chicken	3 lb.. quartered or halves	40-60 minutes total grilling time
Chicken legs or thighs		45 minutes
Pork Chops	1 inch thick	15 minutes each side
Steak	3/4 - 1 inch thick	9 minutes each side
italian Sausage		40 minutes
Pork Sausage	Patty	8 minutes each side
Pork Ribs		45 minutes
Hamburger	Patty	9 minutes each side
Prime Rib		2 - 2 1/2 hours -- use meat thermometer
Pork Roast		Use meat thermometer
Vegetables	All	30-45 minutes total cooking time -- best in covered dish
Biscuits	Canned	9 minutes one side & 5 minutes other side

Smoking

Turkey	15 minutes per pound
Fish	20 minutes total

Steaming

Oysters, clams, crab legs, etc.	Approximately 20 minutes
------------------------------------	--------------------------

NOTE: Remember, the Holland Grill needs to warm up completely. Temperature will remain about 400 degrees F. All grilling times are approximate depending on size, weight and individual taste preference. Grill needs to remain closed at all times during grilling to be accurate with this time chart. Each time grill is opened during the grilling process, increase grilling time by approximately 10 minutes. A time chart in any cookbook may be of some assistance.

GRILLING INSTRUCTIONS

Fish Grilling: Allow grill to warm up for 15 minutes. Place fish on grill and season to taste. Allow 20-30 minutes total grilling time, turning at half the grilling time if desired (turning is not necessary).

Fish Smoking: Make sure grill is where you intend to use it. Close valve on drip pan, and fill with 1 gallon water (hot water speeds up process). Add Brad's Flav-O-Buds to the chip drawer/tray. Light grill. You will feel steam on top of stacks in about 15 minutes, then place fish on grill for approximately 20 minutes. Add seasonings at any time.

Shellfish: (oysters, clams, crab legs, etc.): Same as fish smoking, allow 15-30 minutes grilling time.

Turkey Bar-B-Que: Allow 15 minutes warm up time. Place turkey on its back in center of grill. Allow 15 minutes grilling time per pound. Not necessary to turn.

Turkey Smoked: Follow same procedure as smoking fish. Grill 15 minutes per pound and use meat thermometer to test for doneness.

Chicken Halves or Quarters: Place on grill for 60 minutes. Turn at 30 minutes if desired.

Steak 3/4" - 1" thick: Allow grill to warm for 15 minutes, then place steaks on grill. Allow 6-10 minutes per side. Ten minutes on each side will produce medium well to well done steaks.

Hamburger: Same as steak.

Ribs: Allow grill to warm for 15 minutes, place ribs on grill. Allow 40-60 minutes grilling time. Turn at half the grilling time if desired (not necessary). Baste or dip in sauce at any time.

Roast (pork, beef, lamb, etc.): Place in center of grill. Pans or aluminum foil are not necessary. Allow 20 minutes per pound grilling time. Use meat thermometer.



The Holland Grill Company, Inc.

600 Irving Parkway Holly Springs, NC 27540

Call 1-800-880-9766 or visit www.hollandgrill.com for a dealer near you.

