



Assembly & Operation

30160 G Gas Smoker

DANGER

FOR YOUR SAFETY - IF YOU SMELL GAS:

1. SHUT OFF GAS TO THE APPLIANCE.
2. OPEN SMOKER DOOR.
3. EXTINGUISH ANY OPEN FLAME.
4. PERFORM A GAS LEAK TEST.
5. IF ODOR CONTINUES, KEEP AWAY FROM THE APPLIANCE AND IMMEDIATELY CALL YOUR FIRE DEPARTMENT.

FAILURE TO FOLLOW THESE INSTRUCTIONS AND WARNINGS COULD RESULT IN FIRE OR EXPLOSION, WHICH COULD CAUSE PROPERTY DAMAGE, PERSONAL INJURY OR DEATH.

DANGER

1. Never operate this appliance unattended.
2. Never operate this appliance within 10 feet (3.05 m) of any other gas cylinder.
3. Never operate this appliance within 25 feet (7.5 m) of any flammable liquid.
4. Heated liquids remain at scalding temperatures long after the cooking process. Never touch cooking appliance until liquids have cooled to 115°F (45°C) or less.
5. If a fire should occur, keep away from the appliance and immediately call your fire department. Do not attempt to extinguish an oil or grease fire with water.

Failure to follow these instructions could result in fire, explosion or burn hazard, which could cause property damage, personal injury or death.

DANGER

This instruction manual contains important information necessary for the proper assembly and safe use of the appliance.

Read and follow all warnings and instructions before assembling and using the appliance.

Follow all warnings and instructions when using the appliance.

Keep this manual for future reference.

Installer - leave the manual with the consumer.





Outdoor Leisure Products, Inc.
5400 Doniphan Drive
Neosho, MO 64850

Toll Free: 866-475-5180
8:30am to 4:30pm, Central Time
Monday through Friday



www.olp-inc.com

READ ALL SAFEGUARDS AND INSTRUCTIONS THOROUGHLY!
 YOUR SAFETY IS VERY IMPORTANT - FAILURE TO FOLLOW PROPER PROCEDURES AND SAFEGUARDS
 MAY RESULT IN PROPERTY DAMAGE, PERSONAL INJURY OR DEATH.

 DANGER	 DANGER
<ul style="list-style-type: none"> · This smoker is for OUTDOOR USE ONLY. · Never operate this smoker unattended. · The use of alcohol, prescription or non prescription drugs may impair the consumer's ability to properly assemble or safely operate the smoker. · Never operate this smoker within 10 feet (3m) of any gas cylinder. Never operate this smoker within 25 feet (7.5 m) of any flammable liquids. · Use this smoker only on a level, stable non-combustible surface like brick, concrete or dirt. Do not use smoker on or around any surface that will burn or melt like wood decks, dry grass, leaves, wood rails, asphalt, vinyl, or plastic. · Never operate this smoker under any overhead roof covering, awning or overhang. Never use inside an enclosed area such as screen patios, garage, buildings, tents. Keep a minimum clearance of 10 feet (3m) from all sides of the smoker to all overhead construction and 3 feet or 1m to any walls or rails. · Never use in or on recreational vehicles and/or boats. · Never use this product for anything other than its intended purposes. This smoker is not intended for commercial use. Never use this smoker as a heater. 	<ul style="list-style-type: none"> · Accessory attachments and cookware not manufactured or supplied by Smoke Hollow for this smoker are not recommended for use. · Perform a leak test before each use of the smoker. (See page 18) · Keep the fuel supply hose away from any heated surfaces. · Never attach a gas cylinder, move or alter fittings when the smoker is hot or in use. · Do not attempt to disconnect any gas fitting while the smoker is in operation. · Never fill the cylinder beyond 80 percent full. Overfilled cylinders can release gas. · Never use a gas cylinder if it appears to have dents, gouges, bulges, fire damage, erosion, leakage, excessive rust, or other forms of visible external damage. The cylinder may be hazardous and should be checked by a liquid propane supplier. · The LP-gas cylinder being used must be constructed and marked in accordance with the specifications for LP-gas cylinders of the U.S. Department of Transportation (DOT) CFR 49 or the National Standards of Canada, CAN/CSA-B339, Cylinders, Spheres and Tubes for the Transportation of Dangerous Goods.
<ul style="list-style-type: none"> · Keep the area clear of all flammable liquids, combustible material including but not limited to wood, dry plants including grass, brush, paper, and canvas. · Smoker is HOT while in use and after use - Avoid touching hot surfaces. Always wear protective gloves or mitts when operating the smoker. · Keep children and pets away from the smoker at all times. · Do not allow anyone to conduct activities around the smoker during or following its use until the unit has cooled. The smoker is hot during operation and remains hot for a period of time following its use. · Never move the smoker when it is in use. Allow the smoker to cool below 115°F (40°C) before moving or storing it. · Always wear shoes and protective clothing during operation of this smoker. 	<ul style="list-style-type: none"> · The installation of this smoker must conform with local codes or, in the absence of local codes, with the National Fuel Gas Code, ANSI Z223.1, Storage and Handling of Liquefied Petroleum Gases, ANSI/NFPA 58 or CSA B149.1, Natural Gas Installation Code or CAN/CGA-B149.2, Propane Installation Code. · Before each use, inspect gas hose for any signs of damage and check all nuts and bolts to be sure that they are tight and secure. · When lighting your smoker, do not cover the burner or restrict airflow from the burner. An explosion could occur. · If burner does not ignite, turn off the control valve and gas and wait 5 minutes before trying to light it again. If the burner goes out during operation, first turn the control valve OFF, then the gas cylinder OFF.

READ ALL SAFEGUARDS AND INSTRUCTIONS THOROUGHLY!

YOUR SAFETY IS VERY IMPORTANT - FAILURE TO FOLLOW PROPER PROCEDURES AND SAFEGUARDS
MAY RESULT IN PROPERTY DAMAGE PERSONAL INJURY OR DEATH

 DANGER	 DANGER
<ul style="list-style-type: none">· Do not obstruct flow of combustion and ventilation. Keep the ventilation opening(s) of the cylinder enclosure free and clear of debris.· Keep clear of the smoker hose. Tripping over the smoker hose may result in the spilling of HOT grease or water, causing personal injury or property damage.· In the event of an oil/grease fire, immediately turn off gas supply and call the Fire Department. Do not attempt to extinguish a fire with water. A Type BC or ABC fire extinguisher may in some cases contain the fire.· Keep your hands, hair and face away from the burner flame. Do not lean over or into the smoker when lighting the burner. This smoker has an open flame. Be careful of loose hair and clothing during operation which could catch fire.· After use, always turn the control valve OFF first, then the gas cylinder valve OFF.	<ul style="list-style-type: none">· Always allow the hot water to cool completely below 100° F (38°C) before moving to avoid the possibility of severe burns.· Never use glassware, plastic, or ceramic cookware in this smoker.· Always disconnect the gas cylinder from your smoker when not in use.· Do not store a spare LP-gas cylinder under or near smoker. The gas cylinder safety relief valve may overheat, allowing gas to release causing an intense fire causing death or serious injury.· Cylinders must be stored outdoors, out of reach of children, and must not be stored in a building, garage, or any other enclosed area.· If you smell, hear or see gas escaping, immediately get away from the gas cylinder and call the Fire Department.

USE CAUTION AND COMMON SENSE WHEN OPERATING YOUR SMOKER. READ ALL INSTRUCTIONS,
WARNINGS AND SAFEGUARDS PRIOR TO ASSEMBLING AND OPERATING YOUR SMOKER.

SAVE THESE INSTRUCTIONS



Assembly

Read all safeguards and assembly instructions before assembling and operating your smoker.

Before assembling your new smoker, unpack all the parts from the box. Carefully remove all packing material and lay out all the parts for easy access and identification. Do not discard the carton or packaging until your smoker is fully assembled and operating to your satisfaction.

In order to properly assemble your smoker, you will only need two tools:

- Phillips head screwdriver
- Pliers or 3/8" & 7/16" wrench

(tools not included)

Be sure to have a friend help. The smoker is heavy and must be moved around during assembly and before use.

To use your smoker immediately after assembly, have an L.P. gas cylinder filled by an authorized L.P. dealer or cylinder exchange center. Also, be sure to have your choice of flavoring wood readily available.

(L.P. Gas Cylinder and Flavoring Wood is not included)

For further assistance, including missing or damaged parts, call toll free: 866-475-5180 8:30am to 4:30pm, Central Time, Monday - Friday.

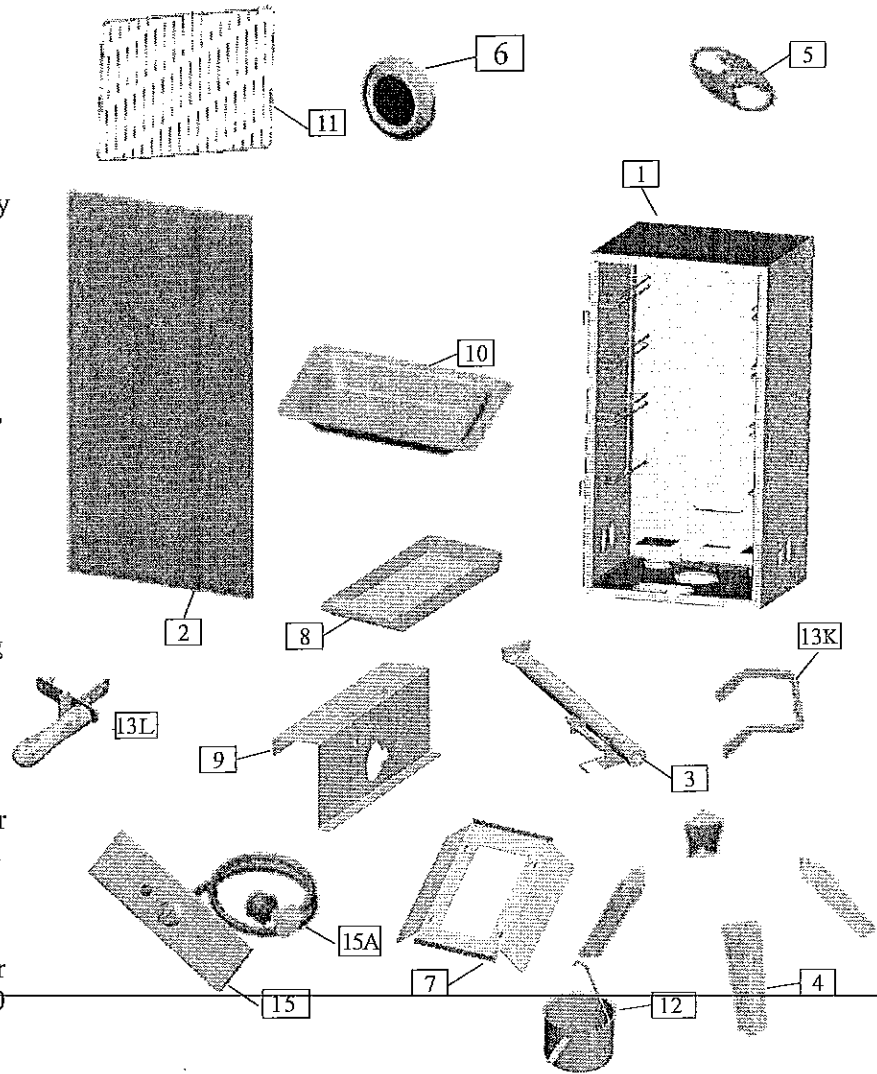

Primary Components			Part No.
Item	Qty	Description	30160G
1	1	Smoker Cabinet Assembly	30160CA
2	1	Smoker Door	30160DR
3	1	Burner Tube Assembly	30160BURN
4	4	Smoker Leg	3A01000
5	3	Damper	3A02000
6	1	Heat Indicator	30160G-16
7	1	Heat Shield/Wood Chip Pan Support	30160G-01
8	1	Wood Chip Tray	30160G-02
9	1	Wind Shield	30160G-03
10	1	Water Bowl	3007000
11	3	Cooking Grid	30CG
12	1	Grease Cup	C012
14	1	Owner's Manual	30160G-04

Assembled Components			Part No.
Item	Qty	Description	30160G
1	1	Cabinet Assembly	30160CA
3	1	Burner Assembly	30160BURN
3A	1	Burner Tube	30160BURN1
3B	1	Burner Electrode	30160BURN2
15A	1	Hose-Valve-Regulator Ass'y	30160HVR
15	1	Control Panel Assembly	30160G-05

Master Hardware Pack Contents			Part No.
Item	Qty	Description	30160G
13	1	Master Hardware Pack	30160HDW
13A	12	1/4-20x5/8" Bolt	Hardware A
13B	4	1/4-20 Flange Nut	Hardware A
13C	9	10-24x1/2" Bolt	Hardware B
13D	3	10-24x1/2" Bolt	Hardware C
13E	3	10-24 Nut	Hardware C
13F	3	10-24 Lock Washer	Hardware C
13G	1	Zip Tie	Hardware D
13H	1	S-Hook for Hose	Hardware D
13I	2	10-24 1/2" Bolt	Hardware E
13J	1	1/4-20 Locking Nut	Hardware E
13K	2	Carry Handle	3A10000
13L	1	Door Handle Kit	30160DHK

Assembly

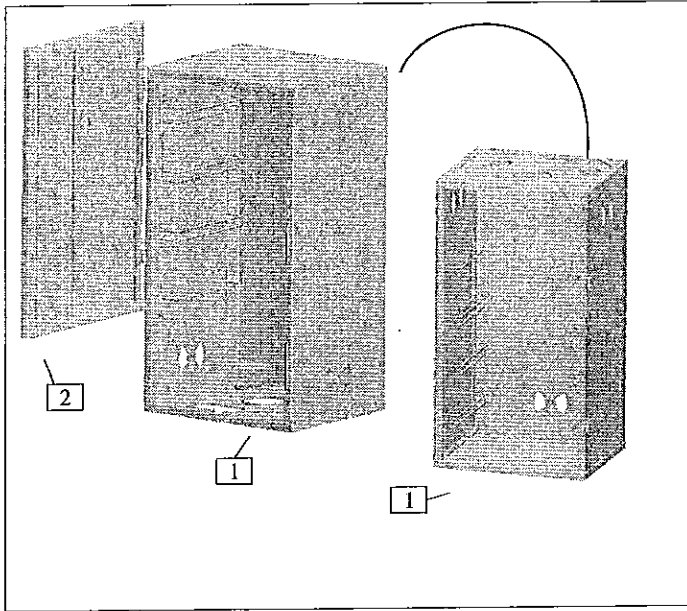

Step 1:

Locate: Cabinet Assembly [1], Door Panel [2]

Note: The door panel [2] is attached to the cabinet assembly [1] by lifting straight up on the door. Set the door panel aside.

Tools Needed: None

Procedure:

Remove the door panel [2] from the cabinet assembly [1] by lifting straight up on the door. Set the door panel aside.

Turn the cabinet assembly [1] upside down.

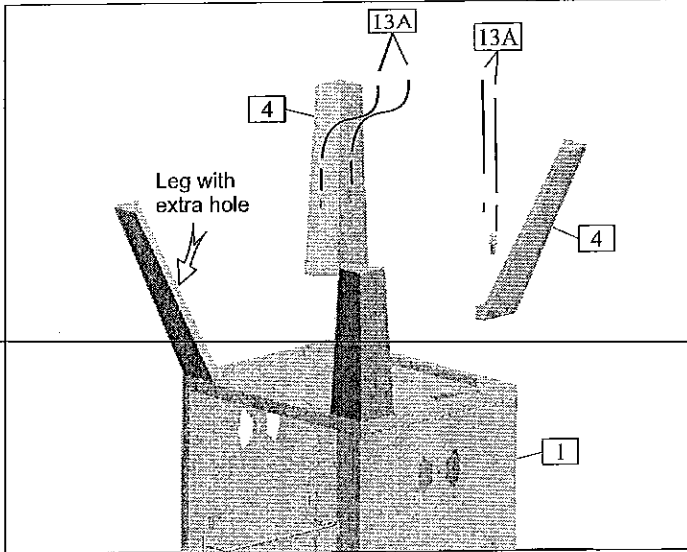

Step 2:

Locate: Four Smoker Legs [4], Eight 1/4-20x 5/8" Bolts [13A] from the hardware A.

Tools Needed: Phillips head screwdriver

Procedure:

Place each leg [4] at the corner of the smoker cabinet assembly [1] as shown. Fasten each leg [4] with two 1/4-20x5/8" bolts [13A]. Nuts are pre-welded to the cabinet.

Note: One leg contains an extra hole on its side and must be mounted at the front in the position shown. This hole will be used later to secure the gas hose to the leg with a zip-tie.

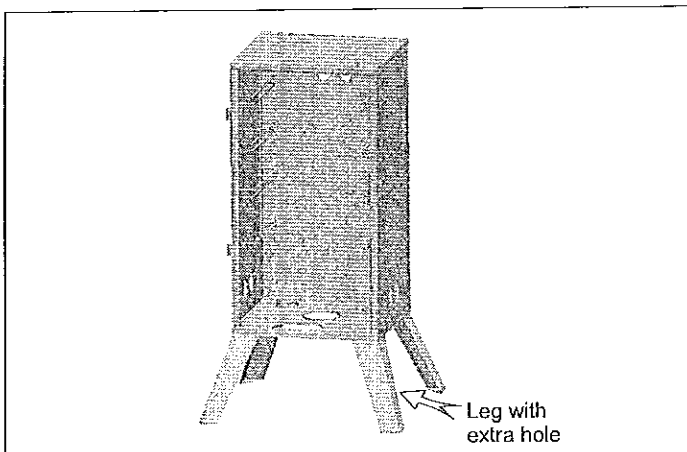

Securely tighten eight bolts.



Assembly

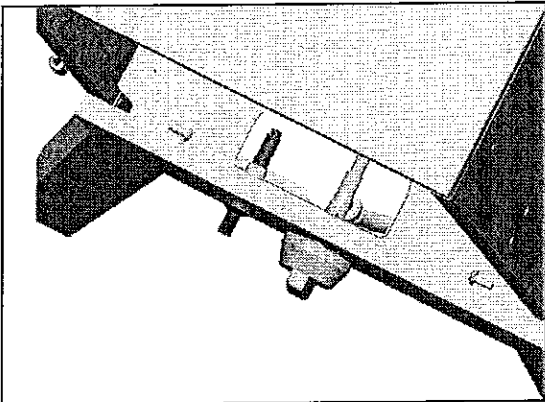

Step 3:

Locate: Control panel assembly [15],
Four 10-24×1/2" Bolts[13C]

Tools Needed: Phillips head screwdriver.

Procedure:

1. You must insert the end of the hose-valve-regulator [15A], through the "D" shaped hole (see picture). Then place the control panel assembly between the front legs as shown.

2. Insert the 4 bolts as shown and tighten them securely

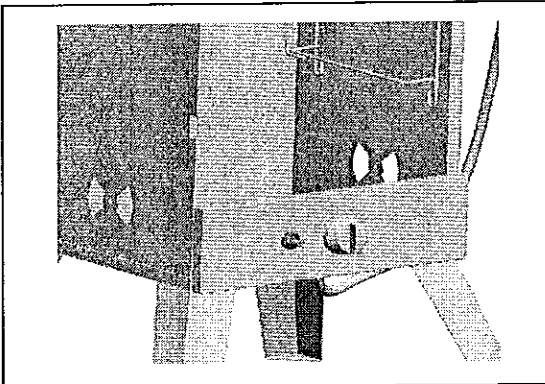
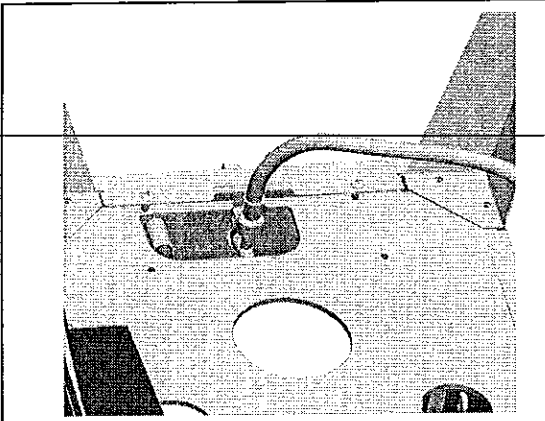
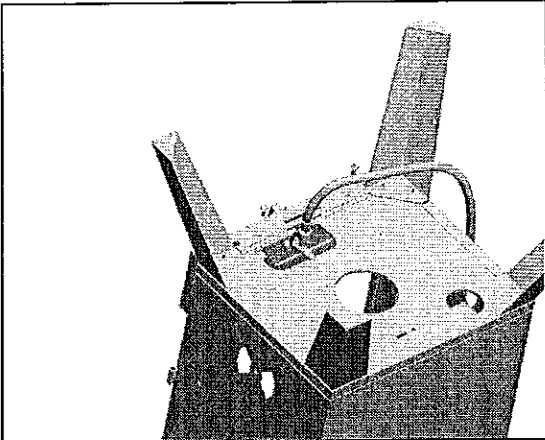

Assembly

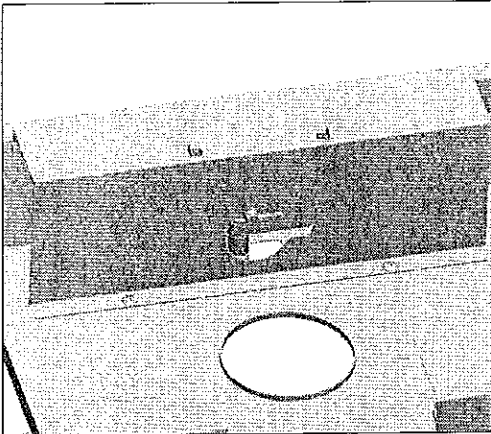

Step 4:

Locate: Wind shield[9], two 10-24×1/2" Bolts [13C]

Place the wind shield as shown and fasten in place with the 2 bolts.

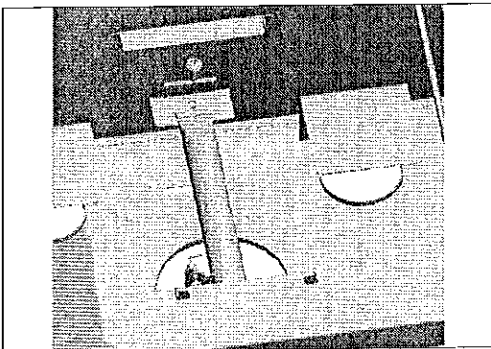
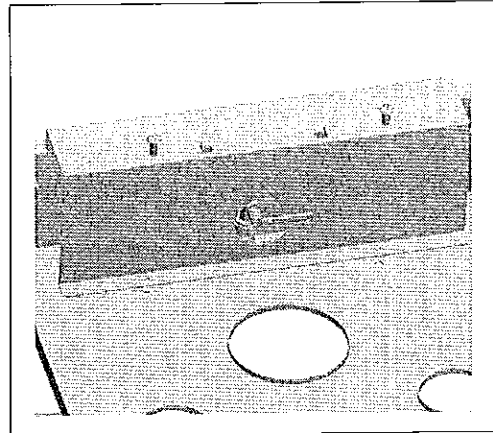

Step 5:

Locate: Burner Tube Assembly [3], three 10-24 x 1/2" bolts [13C]

Procedure:

Attach burner tube by sliding tube end opening onto the gas valve and attach the BACK END of the burner to the welded bracket in the Cabinet, with one bolt. Turn the Cabinet upside down, and attach the "L" shaped burner bracket to the Cabinet with two bolts. Nuts are pre-welded to the "L" shaped burner. Then attach the loose end of the ignition wire onto the connector tab inside the igniter.

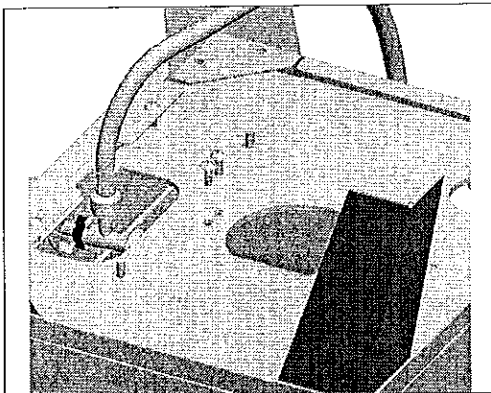
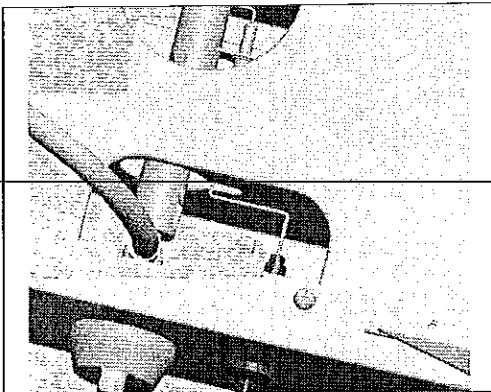

Assembly

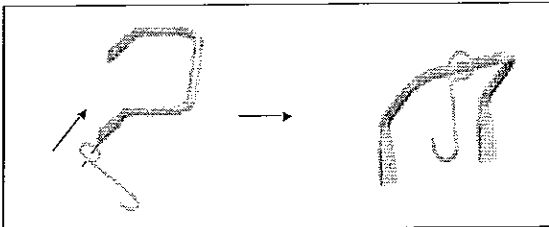

Step 7:

Locate: Two Carry Handles [13K], one S-Hook(13H), Four 1/4-20x5/8" Bolts [13A], and Four 1/4-20 Flange Nuts [13B]

Tools Needed: Phillips head screwdriver and a 7/16" wrench or pliers.

Procedure :

Put the ring end of the S-hook on one carry handle [13K] as shown. Use two 1/4-20x5/8" bolts [13A] and two 1/4-20 flange nuts [13B] to attach the handle on right side of the smoker cabinet [1].

Mount other carry handle [13K] to the left side of the cabinet [1] as shown. Use two 1/4-20x5/8" bolts [13A] and two 1/4-20 flange nuts [13B] to attach the handle.

Securely tighten the bolts.

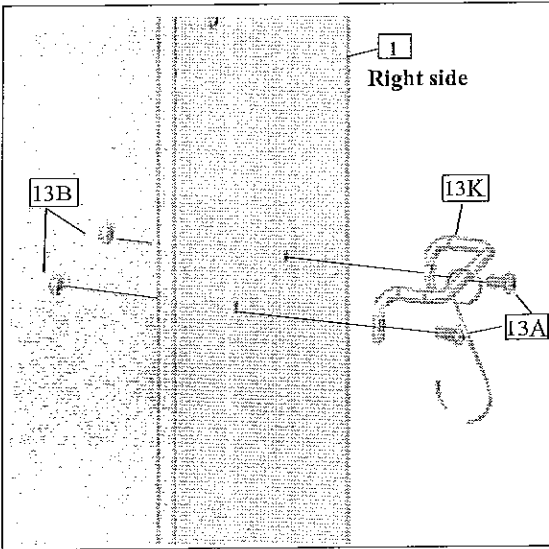

Step 8:

Locate: Door handle kit [13L]

Note: The door handle kit [13L] consists of one door handle (a), one 1/4"-20 locknut (b), two 10-24x1/2" bolts (c), one handle splint.

Tools Needed: Wrench.

Procedure:

First, insert handle kit screw (a) into the door from the outside. Then put one locknut (b) on the screw from the inside and use a wrench to tighten the locknut.

Put the handle splint (d) onto wall using two bolts in correspondings holes and tighten them.

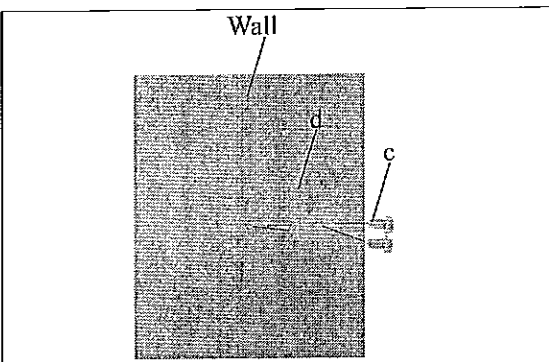
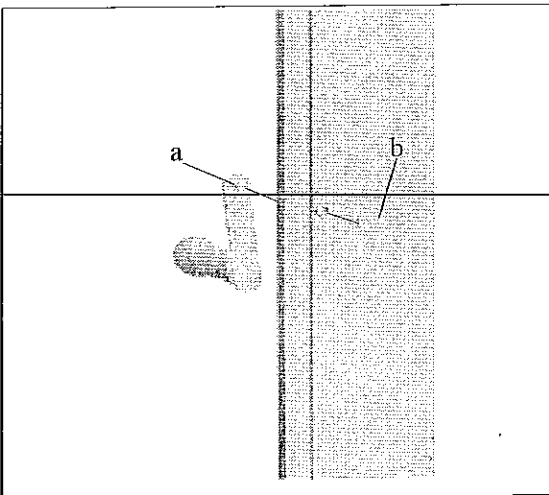



Assembly

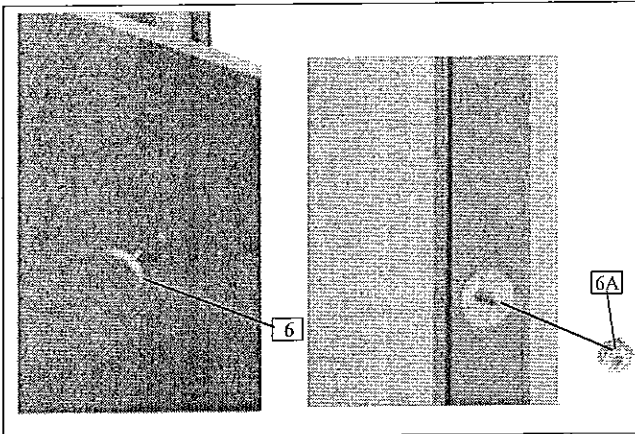

Step 9:

Locate: Heat Indicator [6]

Note: The heat indicator [6] is supplied with one nut .

Tools Needed: Pliers

Procedure:

Mount the heat indicator [6] to the front of the door panel [2] using the one corresponding hole.

From the inside of the door panel, secure heat indicator with the supplied nut and tighten firmly.

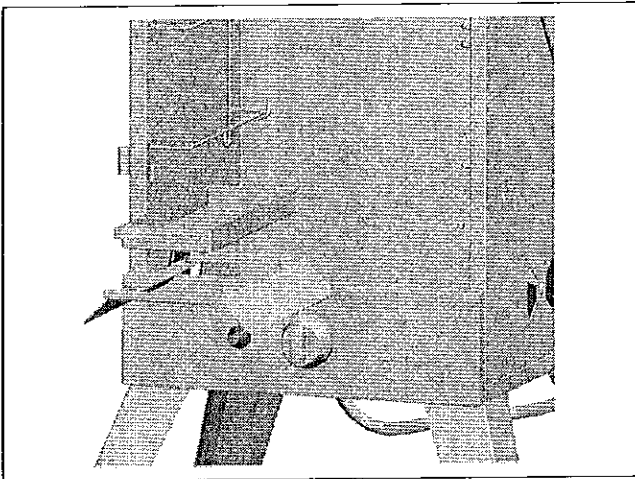

Step10:

Locate: The heat shield /wood chip box support [7] and wood chip tray [8]

Tools needed: None

Procedure

Place the “support” into position over the burner assembly, so that it fits onto the tabs on the wind shield and the tab welded to the smoker backpanel.

Slide the wood chip tray into position on the “support” as shown

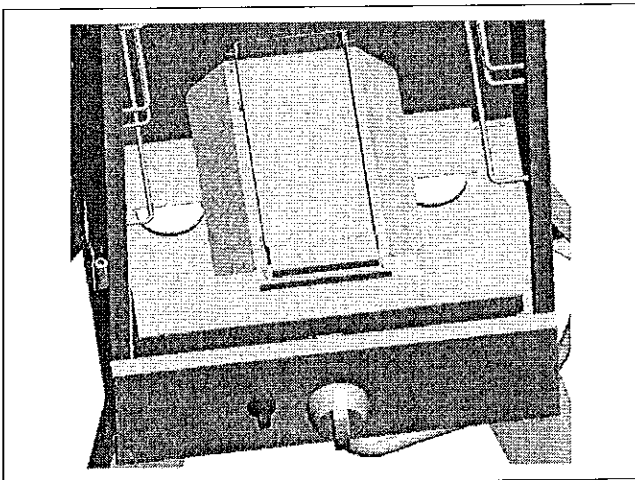

Assembly

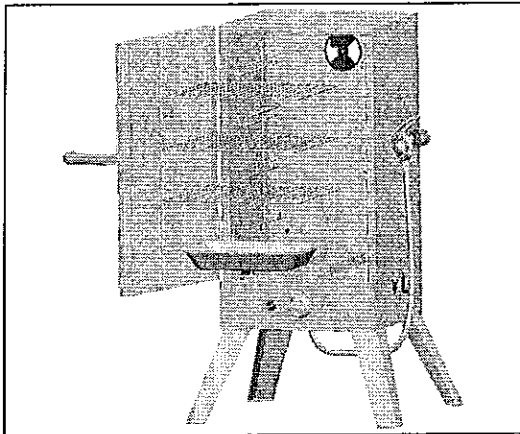

Step 11:

Locate: The three cooking grids [11] and the water bowl [10]

Tools needed: None

Procedure:

Slide each cooking grid into the grid support and water bowl into position as shown.

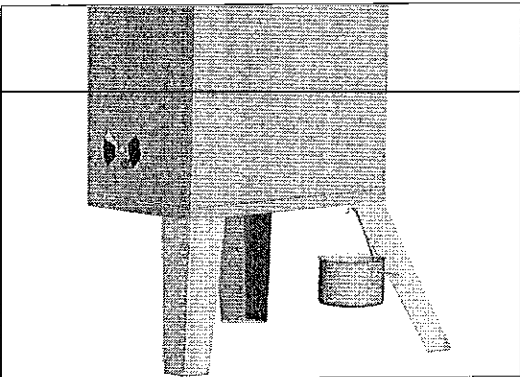
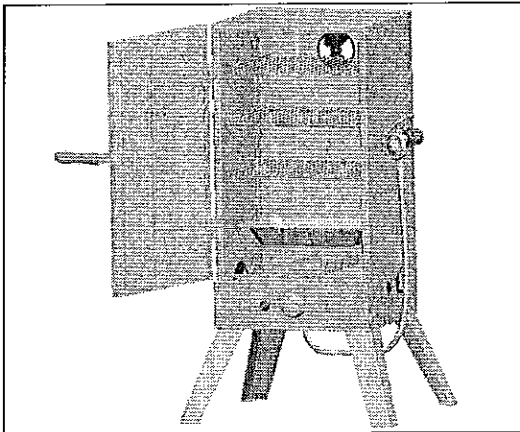

Step 12:

Locate: The grease cup [12]

Tools needed: None

Procedure:

Slide the wire hook up through either 2 1/2" diameter opening in the smoker bottom and fit the hook into the small hole in between the two openings.

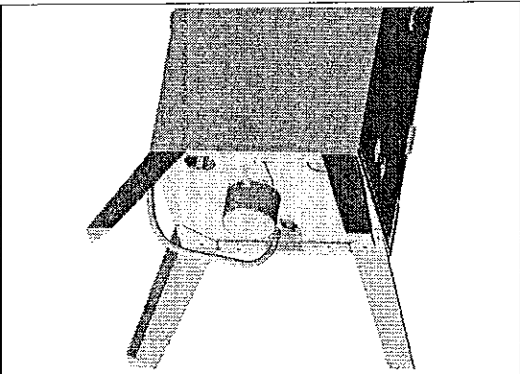



Assembly

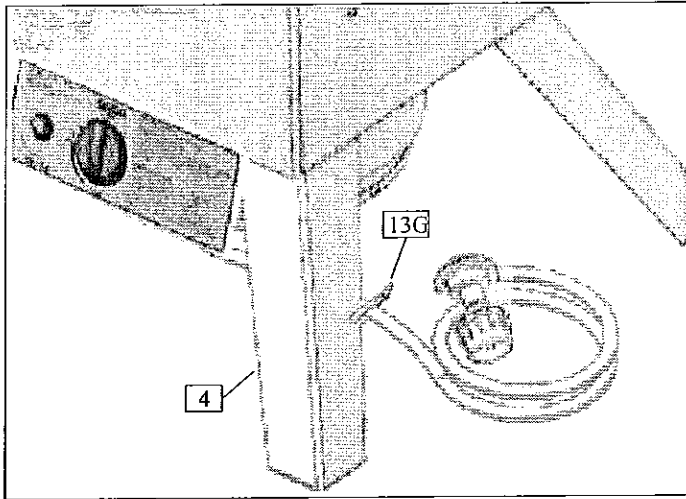

Step 13:

Locate : Zip Tie [13G]

Tools Needed : None

Procedure :

Loop the zip tie [13G] through the outside hole of the front smoker leg [4] as shown.

Capture the gas hose with the zip tie to secure it. Do not pull the zip tie too tight - it may restrict gas flow through the hose.

Assembly of your smoker is now completed. The following pictures show how the assembled unit should look.

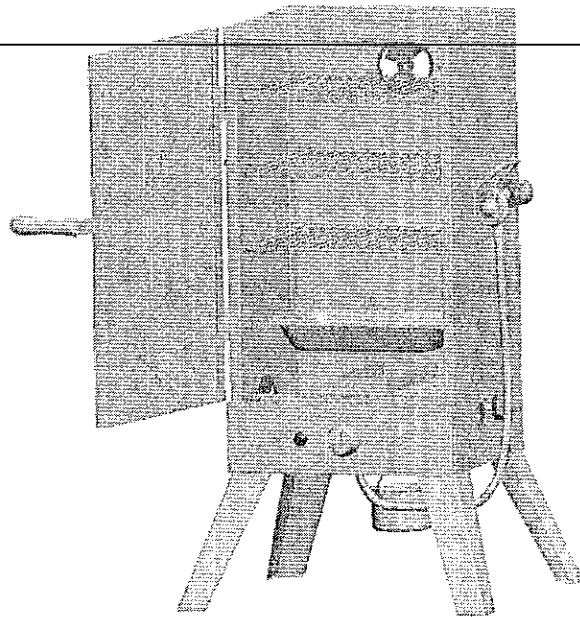
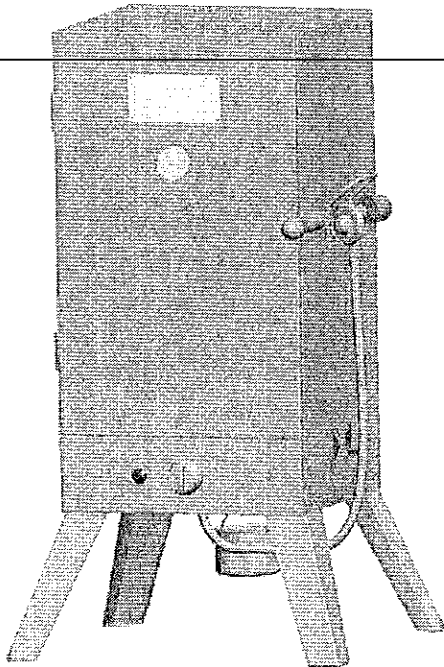

Assembly



⚠ DANGER

ALL INSTRUCTIONS AND SAFEGUARDS MUST BE FOLLOWED TO PREVENT FIRE, PROPERTY DAMAGE, OR PERSONAL INJURY.

IMPORTANT: Any fuel supply cylinder used must be constructed and marked in accordance with specifications for propane cylinders of the U.S. Department of Transportation (DOT) CFR 49, or CAN/CSA B339. The appliance is to be used only with the 20 pound, vertical standing vapor withdrawal type tank.

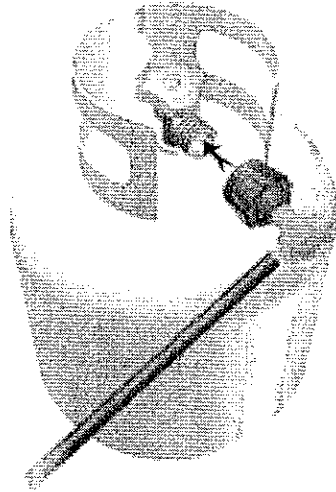

This smoker is designed to operate on LP (Liquefied Propane) gas only. This unit is not to be utilized with a non-self-contained LP-gas supply system.

The 20 lb LP cylinder used with this smoker must conform to the following requirements.

Diameter- 12" (30.5cm)

Height 18" (45.7cm)

With a maximum capacity of 20 pounds

The gas cylinder used must include a collar to protect the cylinder valve. The cylinder supply system must be arranged for vapor withdrawal.

⚠ The instructions stated on gas cylinder tanks have to be followed when filling or transporting tanks. Failure to do so could result in problems relating to overfilling, excessive venting release of gas and to regulator freezing.

Do not allow dirt or foreign material to get into or onto tank connection when it is not attached to the fuel supply system. Place the dust cap on cylinder valve outlet whenever the cylinder is not in use. Only install the type of dust cap on the cylinder valve outlet that is provided with the cylinder valve. Other types of caps or plugs may result in leakage of propane.

⚠ DANGER

⚠ (A) Do not store tanks under or near the smoker.

⚠ (B) Never fill tanks more than 80% full.

⚠ If instructions A and B above are not followed exactly, a fire causing death or serious injury may occur.

Cylinders must be filled before initial use. All handling, transport, filling and storage of LP gas cylinders must be in accordance with *NFPA 58 Storage and Handling of Liquid Petroleum Gases*, or *CSAB 149.1 Natural Gas and Propane Installation Code*. Cylinders must be suitably tied down during transport. Do not place any other items on top of cylinders at any time. Cylinders are not to be exposed to excessive temperatures or high heat.

If there is a question on the identity of your unit and of the type of fuel to be used, please look on the data plate. Units are factory equipped for use on only one type of fuel. These units cannot be, and should not be used on other type of fuels. Doing so can cause severe damage to the unit and the installation area and the added risk of serious injury. Any attempt to operate these smokers on fuels for which they are not design certified voids the manufacturer's warranty.

Gas Tank outlet must have Type 1 gas connection termination in order to mate with gas hose provided with smoker.

The pressure regulator and hose assembly supplied by the manufacturer with the appliance must be used. Replacement pressure regulators and hose assemblies must be those specified by the appliance manufacturer.

The regulator/hose assembly should be handled carefully to prevent contamination by foreign objects and dirt. The assembly should be inspected before use and any dirt or contamination should be wiped off. In order to insure proper operation, any replacement of the fuel tank regulator assembly has to be done with parts authorized by the smoker manufacturer.



⚠ DANGER

ALL INSTRUCTIONS AND SAFEGUARDS MUST BE FOLLOWED TO PREVENT FIRE, PROPERTY DAMAGE, OR PERSONAL INJURY.

⚠ Valve/pressure regulators are factory set to the correct operating pressures. No attempts should be made to adjust these settings!

Connecting the LP Gas Cylinder:

1. The valve on the LP tank must be closed. See that the knob is turned clockwise to a full stop.
2. Check that the control knob on the smoker is turned off.
3. Remove the protective cap from the LP tank valve and coupling nut, if present.
4. Hold the regulator in one hand and insert the nipple into the valve outlet. Be sure the nipple is centered in the valve outlet. The coupling nut connects to the large outside threads on the valve outlet. Use care - do not cross thread the connection.
5. Hand tighten the coupling nut clockwise until it comes to a full stop. Firmly tighten by hand only. Do not use tools.

CAUTION: In the connection process, the regulator side of the connection will seal on the back check in the valve, resulting in a slight resistance. The connection requires about one-half to three-quarters additional turn to complete the connection.

When setting up the smoker and tank, it is recommended to have the tank and smoker on a line perpendicular to the wind direction.

The gas hose/regulator assembly should be totally extended to the maximum distance so that the hose is straight and the tank is as far from the smoker as it can be.

LP tanks are intended for operation in the upright position only.

Care should be taken to protect the fuel supply hose from damage from either foot or vehicle traffic.

If the appliance is not in use, the gas must be turned off at the supply cylinder and the cylinder should be disconnected from the appliance.

Storage of the appliance indoors is only permissible if the cylinder is disconnected and removed from the appliance.

Cylinder must be stored outdoors out of the reach of children and must not be stored in a building, garage or any other enclosed area.

Leak Testing (Checking for gas leaks)

After all connections are completed, check all connections and fittings for leaks with a soap solution.

- Mix dish soap with water; about 3:1 mix ratio.
- With all valves closed, apply the soap solution to all gas flow connections and fittings.
- Open tank valve about 1-1/2 turn.

Presence of bubbles at areas of wet solution indicates a gas leak.

If leaks are detected or you smell or hear gas, shut off the valve and repair the leak or replace the defective part. Do not use the smoker until all leaks are corrected.

⚠ DANGER

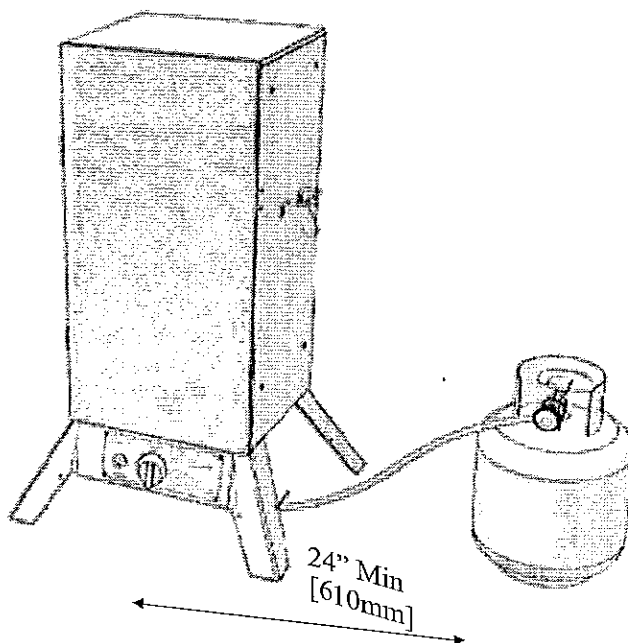



Pre-Use Procedures

Your smoker has been packaged with a retail store level point-of-purchase label that hangs on the front of the door panel. This label must be removed before use. To remove the label, simply cut or tear along the indicated line and pull the top portion of the label from behind the name plate.

Before you cook food in your smoker, it is important to “season” your smoker. Seasoning seals the paint and interior of your smoker to enhance flavoring, durability, and overall performance. This is also referred to as the “break-in” process.

If your smoker requires any touch-up paint on the inside of the cabinet, the only time you should apply paint to the inside is before the seasoning process. Paint should not be applied to the interior of your smoker after your smoker has been used. Paint toxins may contaminate your food. However, if paint becomes necessary after use, see the section in this manual concerning After Use Care and Maintenance.

To season your smoker, simply use it as you normally would; only do not cook any food. You will need to follow all of the operating procedures in the next few sections of this manual.

Using your desired flavoring woods and marinades, burn your smoker at lowest temperature for 45-60 minutes. Let the smoker cool, and clean out the used water and wood.

Once seasoning is complete, your smoker's interior will have a durable, seasoned coating.

Adding Water

To add water before cooking, simply remove the water bowl and fill it with water up to 1” (2.5 cm) below the rim. Then replace the bowl to the rack.

To add water while the smoker is hot, DO NOT pull the water bowl out beyond the rack. Use a clean cup or watering can to add water to the water bowl while in use.

For easier cleaning, line the water bowl with aluminum foil before each use.

Adding Wood

To add wood before cooking, simply fill the wood chip box with your choice of flavoring hardwood chips. The amount and type of wood you use is entirely up to you. One full box is typically enough for several hours of smoking. Once the box is filled with wood, place the lid on top of the box and set the box in the smoker.

To add wood while cooking, use tongs or long handled pliers to remove the box lid and to place the pieces into the wood chip box without removing the box. It is not recommended to remove the wood chip box while the smoker is in operation.

CAUTION! : The wood chip box and lid get very hot. Avoid handling them while in use. Always wear protective oven mitts when handling hot components.

Using Flavoring Wood

Small wood chips work best inside the wood chip box.

Use dry hardwoods such as hickory, pecan, apple, cherry, or mesquite.

Most fruit or nut tree woods produce excellent smoke flavoring.

Do not use resinous woods such as pine or plywood. These usually produce unpleasant flavoring.

Experiment with different types and quantities of wood chunks, chips, or sticks. Different woods can also be mixed.

To produce more smoke and to prevent fast burning, pre-soak the wood chips in a separate bowl of water for at least 20 minutes, or wrap the chips in perforated aluminum foil.

Most smoke flavoring occurs within the first hour of cooking. Adding wood chips after the first hour is typically not necessary unless extra smoke flavoring is desired.



LP Gas Lighting Procedure

1. Check all connections for leaks using the leak test as explained on page 18.
2. Open the smoker door.
3. Check for any blockage to the venturi tube or burner. Remove any foreign objects or matter.
4. Be sure the burner control knob is in the "OFF" position.
5. Open the LP cylinder valve 1-1/2 turn by turning counter-clockwise.

6. To light unit with the push-button igniter, push in and turn the burner control knob counter-clockwise to the HIGH setting.

7. Immediately push the igniter button to click it several times (you should see a small spark jumping from the end of the electrode rod to the side of the burner). If the burner does not light within 3 to 5 seconds, turn the burner control knob OFF and wait five minutes before repeating the steps again. If burner still fails to light try match lighting the smoker using the instructions noted below.

8. Once the burner is lit, then close the door to allow heat to accumulate. The dampers can then be adjusted to the desired setting to allow proper air flow and combustion. Damper adjustment tips are listed on the next page.

To match light the burner, repeat steps 1 thru 5 of the igniter lighting system above and continue with the following procedure:

Remove the wood tray and its stand from inside the smoker. Strike a paper match and drop it into the burn chamber, next to the burner.

Quickly turn the control knob to the light high setting position. If the burner does not light within 4 or 5 seconds, turn the control knob off, wait 5 minutes, and repeat the process.

If the burner flame is accidentally extinguished, turn the control knob off, wait 5 minutes, and repeat the lighting procedure.

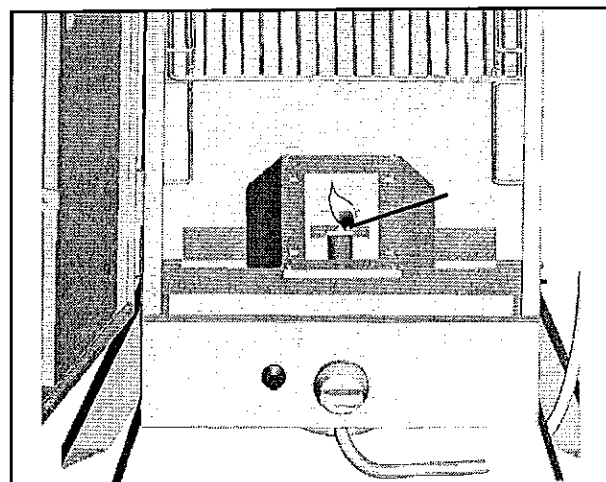
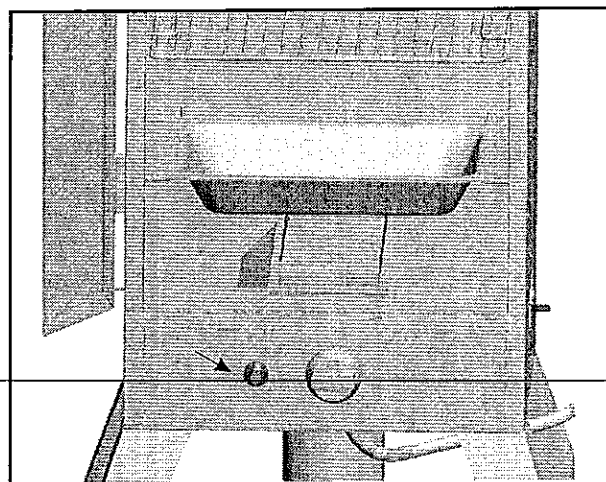
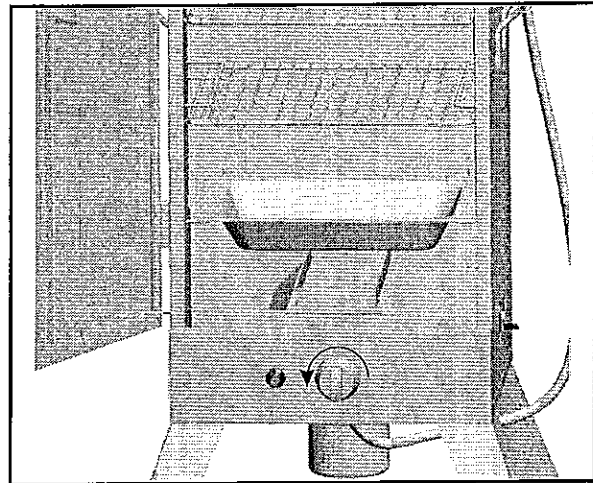



Damper Adjustments

Temperature maintenance is best controlled by different damper adjustments. The key to effective smoking is to watch your heat indicator on the door and adjust the damper accordingly. For better performance, rotate the smoker to where the front of the cabinet is facing the wind. This allows the adjustment of the damper to be more effective and accurate.

Opening the damper helps to exhaust both the heat and smoke. The damper should never be fully closed.

Cooking Instructions

IMPORTANT: Before each use, clean and inspect the hose and the connection to the LP gas cylinder. If there is evidence of abrasion, wear, cuts or leaks, the hose must be replaced before the smoker is used. Refer to the "leak test" instructions in the LP Tank connection portion of this manual.

- Fill the wood chip tray with flavoring wood chips and place the tray inside the smoker as instructed in the assembly section of this manual. Refer to the section that explains flavoring wood for recommended use of flavoring wood.

- Place the water bowl inside the smoker in the lowest rack position as explained in the assembly section of this manual. ~~Carefully fill the water bowl with water or~~ marinade up to 1 inch below the rim. A full bowl will last for approximately 2-3 hours. Do not overfill or allow water to overflow from the water bowl.

- Insert or adjust the cooking grids in to the desired rack positions. For better access to the food with tongs or spatulas, make sure the grid wires run front to back as explained in the assembly section of this manual.

- You are now ready to light the burner. Refer to the Lighting Procedure on the previous pages of this manual. The heat from the burner will allow the wood chips to burn, causing the flavoring smoke to accumulate. Adjust the dampers to control the heat.

- Place the food on the cooking grids in a single layer with space between each piece. This will allow smoke and hot moisture to circulate evenly around all the food pieces.

- Smoking for 2 to 3 hours at the ideal constant cooking temperature of 225° to 250° F (110° to 120° C) will get the best results. This temperature is according to the heat indicator mounted on the front of the smoker. For more tender and heavily smoked meat, a lower temperature may be preferred. If time is critical, a higher temperature range is recommended.

- Check water level periodically and add water if low. For best results and to retain heat, avoid opening the door of the smoker while in use. When the door must be opened, only open it briefly. The smoker will quickly resume cooking temperature after the door is closed.

- Always use a meat probe thermometer to ensure food is fully cooked before removing it from the smoker.

- After each use, and after the smoker is cooled, carefully remove the water bowl from the smoker, empty the water, and clean the water bowl.

Shutting the Smoker Off

CAUTION: The smoker can become very hot while in use. Do not touch any portion of the smoker except for the door handle and burner control knob. It may be necessary to use protective gloves.

- Turn the burner control knob off by pushing in and rotating clockwise. The burner flame should then go out.

- Turn off the LP cylinder valve by turning the knob clockwise until it stops.

- Follow all warnings and safety precautions before removing meat from smoker or preparing the unit for storage. Please see page 23 for proper storage procedures and the important warnings and safeguards on pages 3 and 4.



Temperature Chart

Refer to this USDA Standard chart for properly cooked meat temperature.

IMPORTANT: Measure the meat temperature using a meat probe thermometer. The heat indicator on the smoker gives the heat temperature inside the smoker cabinet, but is not an accurate measurement of the meat temperature.

	Fahrenheit (°F)	Celsius (°C)
Beef		
Rare	120°F - 125°F	45°C - 50°C
Medium-Rare	130°F - 135°F	55°C - 60°C
Medium	140°F - 145°F	60°C - 65°C
Medium-Well	150°F - 155°F	65°C - 70°C
Well Done	160°F - Higher	70°C - Higher
Lamb		
Rare	135°F	60°C
Medium-Rare	140°F - 150°F	60°C - 65°C
Medium	160°F	70°C
Well Done	165°F - Higher	75°C - Higher
Poultry		
Chicken	165°F - 175°F	75°C - 80°C
Turkey	165°F - 175°F	75°C - 80°C
Pork		
Fresh Pork (Raw)	160°F - 170°F	65°C - 70°C
Ham (Pre-Cooked)	140°F	60°C
Ham (Un-Cooked)	160°F	70°C
Fish		
(Cook until opaque and flaky)		



⚠ DANGER

- Use caution when lifting and moving the smoker to avoid strains or back injury. 2 people are recommended to lift or move the smoker.
- DO NOT store the smoker near gasoline or other combustible liquids or where combustible vapors may be present. Keep the area around the smoker clear and free of combustible materials and vapors.
- DO NOT store this smoker in an area accessible to children or pets. Store the smoker in a dry, protected location.
- DO NOT allow anyone to conduct activities around the smoker following use until it has cooled. It is hot during operation and remains hot for a period of time following use.
- This smoker becomes extremely hot - allow the smoker to cool completely before handling. If you must handle the smoker while it is hot, ALWAYS wear protective oven mitts or heat resistant gloves when handling the smoker or its components. Allow the smoker to cool before removing and cleaning the grease pan.

Care and Maintenance to be performed before each use:

CAUTION: All care and maintenance procedures are to be performed only while the smoker is turned off and cooled.

Clean the water bowl and cooking grids with hot, soapy water. Rinse and dry thoroughly. You may prefer to coat the water bowl and cooking grids lightly with cooking oil or cooking spray.

Frequently check and clean the venturi and burner for insects and insect nests. A clogged tube can lead to fire outside the smoker. Also make sure the smoker does not have any foreign objects obstructing the flow of combustion and ventilation air.

To clean the inside and outside of the smoker cabinet, simply use a damp cloth. Spray-washing with a water hose is not recommended. All moisture should be wiped away and not allowed to stand inside or on top of the smoker. Once cleaned, you may prefer to lightly coat the interior of the smoker cabinet with cooking oil or cooking spray.

If rust is present on the exterior surface of the smoker, clean the area with steel wool or emery cloth and use heavy duty, heat resistant paint.

NEVER apply additional paint to the interior of the smoker. If rust is present on the interior of the smoker, clean it thoroughly with steel wool or emery cloth and lightly coat the area with cooking oil or cooking spray to help minimize recurring rust.

GOOD FLAME BAD FLAME

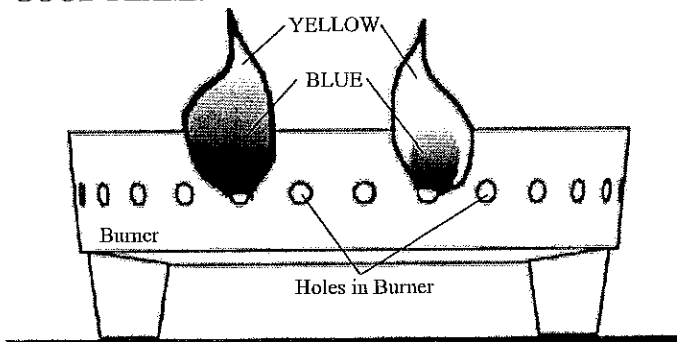

FLAME CHECK

When an LP tank is not connected, and to help prevent dirt or other foreign particles from clogging the regulator, hang the end of the regulator hose from the side handle using the supplied S-hook.

During each use, inspect the flames at the burner. A good flame should be blue with a yellow tip about 1 inch in length. If flames are excessively yellow and irregular, oil residue and food deposits may be collecting on the burner. Try cleaning the burner surface and the holes to improve the flames. Bad flames may also be caused by poor regulator-to-venturi attachment. Always let the smoker cool before cleaning or checking the assembly.

To protect your smoker from weather, always keep your smoker covered while not in use.

Keep the area clear of all flammable liquids, combustible material including but not limited to wood, dry plants including grass, brush, paper, and canvas.

The smoker may be stored indoors only if the cylinder is disconnected and removed.

Limited Warranty



This Smoke Hollow™ smoker is guaranteed against broken or damaged parts at time of purchase. All parts carry a 1-year limited warranty with the exception of the water bowl, which is guaranteed to be free of defects for 90 days. Paint is guaranteed to be free of defects for 90 days except for rust, which may appear after repeated use.

This warranty does not cover damage or issues related to neglect, abuse, or modifications to the product. Repair labor is not covered.

All parts that meet the warranty requirements will be shipped at no-charge via the discretion of the Customer Service Department (ground shipments, US Mail, or Parcel Post ONLY). Any special handling charges (i.e. Second Day, Overnight, etc.) will be the responsibility of the consumer.

All warranty claims apply only to the original purchaser and require a proof of purchase verifying purchase date. Do not return parts to our address without first obtaining a return authorization number from our customer service.

This service is available by calling 866-475-5180, 8:30am to 4:30pm, Central Time, Monday through Friday, or write to Outdoor Leisure Products, Inc., 5400 Doniphan Drive, Neosho, MO 64850.

This warranty may give you specific legal rights that vary by state.

Outdoor Leisure Products, Inc.
5400 Doniphan Drive
Neosho, MO 64850

©2006 Outdoor Leisure Products, Inc. Smoke Hollow and the Smoke Hollow logo are trademarks of Outdoor Leisure Products, Inc. and are not to be used without express permission by Outdoor Leisure Products, Inc.

Smoke Hollow Wood Smokers Tips & Recipes

Getting Started

Before you start smoking make sure you have the proper utensils necessary. First you will need two thermometers. One for checking the inside temperature of your smoker and the other for checking the internal temperature of your meat. The outside temperature gauge will give you an indication of the temperature inside your smoker, but it is always best to check to ensure the proper cooking temperature. The meat thermometer will be used for checking the internal temperature of the meat for preferred doneness.

Good tongs or a meat hook will also be needed when you are smoking. Tongs can be used on your smaller cuts of meat or if you choose to smoke vegetables. If you prefer not to hang your sausage while smoking them the tongs can be used then too. A meat hook is suggested when smoking larger cuts of meat. Also when using a meat with a rub or sauce the meat hook will allow you to handle the meat without knocking off any seasonings.

Always use heavy-duty oven mitts when moving the hot smoker racks or large pieces of meat. When adding extra water or wood chips to your smoker the oven mitts will help prevent injury caused by extreme heat.

Use aluminum foil to wrap when meat has reached desired color and temperature. The foil will protect your meat from the wood resins darkening your meat any further.

Seasoning Your Smoke Hollow Smoker

First, before cooking with your Smoke Hollow Smoker make sure you have seasoned it properly. You can use any cooking oil to season your smoker, peanut or vegetable oils work just fine. After applying the oil to the inside of the smoker, making sure the entire inside is covered, turn your smoker on the high setting and let the smoker burn for two hours, this allows the heat to burn off any dust or residue left during the manufacturing process. Also the oil will seep into the imperfections in the metal and create a water-proof surface to help prevent rusting.

Popular Woods for Smoking Meats

The selection of wood being used to cook your meat is based mostly on personal preference. Location on the other hand also plays a role for what is popular. The flavor of each wood greatly differs from one to the other based on which meat you are cooking. We have listed some of the most popular woods below.

Alder. This Pacific Northwest wood offers a truly unique sweet flavor. Used mostly for cooking salmon and other fish. Also tastes great with any seafood and vegetables.

Apple. A popular Northeast flavor, just like the apple itself, this wood produces a sweet fruity aroma when used. Apple wood will flavor any ribs, ham or poultry dishes very nicely.

Cherry. Like any fruit wood used for smoking the cherry wood will offer a sweet fruity flavor. It is not a strong smoke flavor so its often mixed with other more smoky flavored woods. Also, like apple wood, the cherry wood is great with any ham or poultry.

Hickory. An old time favorite and seems to be the most used wood for smoking. It adds a very heavy smoke flavor to your meats. Hickory is a wood that can be used for mixing with other woods, about half and half. Another reason hickory is very popular is

because it's so easily found. Hickory provides great smoke flavor for ribs, ham and most all red meats.

Pecan. Just like the other fruit woods the pecan wood gives a sweet flavor to your meats. Pecan is used mostly for fish, poultry and vegetables. Because it burns cooler this wood works great when smoking larger cuts of meat.

Maple. This is the wood for cooking your hams and poultry. Maple will give you a sweet and not too strong flavor.

Mesquite. Mesquite is the southwest favorite. It gives a very strong flavor and can be over used very easily. Mesquite is not recommended when cooking large cuts of meat unless mixed with another wood. Works great with a smaller portion that takes less time to smoke.

Oak. Naturally a very heavy smoke flavor. Should be used by mixing with another wood, a fruit wood would be suggested. Smokes well with any meat just be careful not to overuse.

Using your Smoke Hollow Smoker

Electric Smoker

Our Smoke Hollow Electric Smoker is most popular for its convenience. The short preparation time and its ability to sustain a constant temperature throughout the smoking process has made this one of our top selling models. Once setting the temperature of the smoker you will not have to stand and continually monitor the smoker. Just check temperature gauges as meat continues to warm up to make sure the internal temperature sustains your desired cooking temperature.

After the smoker has been properly seasoned it is ready to be used. The electric smoker will offer you a temperature range from 150 degrees to about 250 degrees while cooking. When using our electric smoker it is not necessary to soak your wood chips before cooking. Before cooking always preheat your smoker to desired internal temperature. Always double check your internal temperature with another thermometer. While preheating smoker add water and called on amount of woodchips.

The suggested cooking range for our electric smoker is 220 degrees to 240 degrees. These temperatures will allow a slow cook for your meats while also offering the intended smoke flavor. If cooking small, thinner cuts of meat, the temperature may need to be

lowered to allow a longer cook time. Jerky for example is cooked around 190 degrees until desired dryness is reached. A good simple rule for smoking is to allow yourself 30 minutes per pound of meat. When desired internal temperature of meat is met wrap in foil to secure moisture inside and to protect from further browning.

After cooking and smoker has cooled a simple cleanup should be done. This is easy, just use a damp cloth or paper towel and wipe down cooking grids, water bowl, and wood chip pan. Never use any cleaning products on your smoker. The cleaners will strip the smoker of its seasoning and will create an acrid aroma while smoker is in use. For easier clean-up fit a piece of aluminum foil underneath the heating element to catch the grease drippings from your meat.

Using your Smoke Hollow Smoker

Gas Smoker.

Our gas smoker is operated basically the same way except for the fuel used for burning. One difference between the smokers is that our gas smoker will cook hotter and faster if not properly watched. The range of cooking temperatures in our gas models is about 225 degrees and can reach as high as 350 degrees. This is important to know when preheating and cooking with these models.

Start again by adding wood chips and water to your smoker. Since the gas burns hotter adding water to water bowl maybe necessary during the cooking process. This will keep your meat moist and flavorful. Before adding any meat to your smoker allow the smoker to produce full smoke and proper cooking temperature. And always check the internal temperature of smoker with a different thermometer to assure that front heat indicator is correct.

During cooking check the internal temperature of smoker. If temperature does change proper adjustments should be made. Cooking time has many factors: the size of the meat and the shape of the meat, type of meat, the distance of the meat from the source, temperature you are cooking at, and the outside temperature. Smoking meat is a slow process so take your time. All these factors make it very important to use both thermometers to ensure your proper temperature of meat. After desired internal temperature is met wrap meat in foil to protect from any further browning.

Clean-up for our gas smoker is simple. After smoker is cooled remove the cooking grids and wipe off with damp cloth or paper towel. The same goes for the inside of the smoker. Do not use cleaning supplies on the inside of smoker. This will strip away the seasoning of the smoker and could cause acrid fumes during future use, ruining the flavor of the meat.

Temperatures of Meats

The USDA suggests the following internal temperatures of meats for safe eating.

- * Beef, veal, lamb steak, roast and chops may be cooked to 145 degrees.
- * All cuts of pork are to be cooked to 160 degrees.
- * Ground beef, ground lamb, and ground veal are all to be cooked to 160 degrees.
- * All poultry should reach a safe internal temperature of 165 degrees.

Tips for Different Meats and Cuts

~~Smoked Pork~~

Always wash meat thoroughly in cold water, dry to remove excess water, then add your favorite or seasoning. Preheat smoker to 225 degrees and place loin in center of smoker. Cook until meat has reached 165 degrees internal temperature. Remove from smoker and wrap in heavy duty foil. Let meat stand until internal temperature has reached 170 degrees, then uncover and let cool. Slice it 1/4 inch thick or shave it, either way it will melt it your mouth.

Brine. A brine is a marinade for smoked meats. The easiest of brines to make for pork is as follows:

- 8 cups boiling water
- 2/3 cup kosher salt
- 1/2 cup packed brown sugar

Stir together ingredients. Let cool to room temperature. In medium sized bowl place pork and pour brine over the meat. Use two heavy plates to keep the pork below in the brine. Refrigerate and let set for 12 hours. Then pour off brine and rinse pork, patting dry also. Bring pork to room temperature. You are ready to smoke your pork.

Smoked Pork Ribs

Wash the ribs in cold water and place on cutting board. Cut away any excess fat or skin from the bottom of the ribs. Turn ribs bone side up and peel the membrane from the back of the bone until fully removed. Use favorite pork rub seasoning on both sides of the ribs. Preheat smoker to 225 degrees and place into smoker rib bone side down. After one hour turn the rib bone side up and let cook for another hour. Now if you want to add BBQ sauce, remove ribs from smoker and pour a one inch strip down the center and wrap in foil. Place back into smoker for 1/2 hour. Start checking ribs every 15 minutes. When the rib meat easily separates when pulling with your fingers your ribs are done. Now remove from smoker and place on platter to cool.

A simple dry rub for ribs is as follows:

- 1/2 cup fresh ground pepper
- 1/2 cup ground cayenne pepper
- 1 cup dark brown sugar
- 3 tablespoons salt

Mix together in bowl. Rub on both sides of ribs before smoking.

Smoked Beef Brisket

Select a 8 - 6 lbs brisket, one with a little marble to it. Feel free to trim as much fat as desired. Use your favorite beef rub or seasoning and rub it on liberally. Preheat smoker to 225 degrees and place brisket in smoker for three hours. Then place brisket in an aluminum pan and pour 8 oz of Allegro over the brisket. Cover the pan and brisket with foil, place back into the smoker until internal temperature of the meat reaches 170 degrees. Remove pan and brisket from smoker and let stand. Remove the brisket from pan and cut into 1/4 inch slices, cutting against the grain. Use juice from pan to pour over sliced meat or for dipping.

Prime Rib

Select a bone on prime rib, 6 - 8 lbs. Rub with your favorite beef seasoning. Preheat smoker to 225 degrees and place prime rib in the center of the smoker. After 3 hours place the prime rib in aluminum foil pan and covering it with foil. Place covered brisket back into smoker. Watching it closely, remove the meat when internal temperature reaches 145 degrees. After removing the brisket let it stand still covered. The internal temperature will still rise up to 10 degrees while standing. Medium rare temperature is 155 - 160 degrees. Slice to desired thickness and use juice from pan for an au jus dipping sauce.

Fish

Select a nice 3/4 inch thick fillet. Wash fillet thoroughly in cold water and lay on a paper towel until water is not visible. Melt a stick of butter in the microwave. Sprinkle liberal amount of dill weed in the butter. Lay fillets on aluminum foil and fold a lip a around the edges to contain the butter. With a basting brush, brush the butter and dill weed mixture onto both sides of the fish. Preheat smoker to 225 degrees. Place

fish in the smoker. Check the fillets every 15 minutes for visible moist look. Brush with butter and dill weed when needed. Fish should start to flack after about 45 minutes. When fish start to flake, carefully remove from smoker and serve.

Smoked Chicken

Remove chicken parts from package, wash thoroughly and place on paper towel to dry. Sprinkle favorite rub on both sides of all chicken parts. Preheat smoker to 225 degrees. Place chicken in smoker. After 30 minutes turn chicken over. With internal temperature gauge check chicken temperature. Always check the meat nearest the bone. When temperature of the chicken reaches 180 degrees it is done. During the last 15 minutes of cooking you can brush your favorite BBQ sauce for additional flavor.

Smoked Turkey

Select a 12 - 15 pound turkey. Remove turkey from package. Remove the insides of the turkey. Wash turkey thoroughly and place on paper towel to dry. Rub olive oil inside and outside of the turkey. Place your favorite rub or seasoning on the skin of the turkey and inside the cavity. Preheat smoker to 225 degrees. Place turkey in smoker. You may want to baste turkey with butter for added moisture. When turkey reaches color, remove from smoker and place in foil pan. Cover the pan and turkey with foil and place back in smoker. Continue cooking at 225 degrees. Check internal meat temperature where the thigh meets the side of the turkey. Check temperature every 30 minutes for doneness. Turkey should take about 45 minutes per pound to cook. Serving temperature for the turkey is 180 degrees. When internal temperature reaches 180 degrees the bird is done and ready to serve.