

# GADABOUT

*Mobile* Evaporative Air Cooler



**Owner's Manual**

**Model #'s**

**M300**

**M400**

**M500**

**Instruction Manual!**

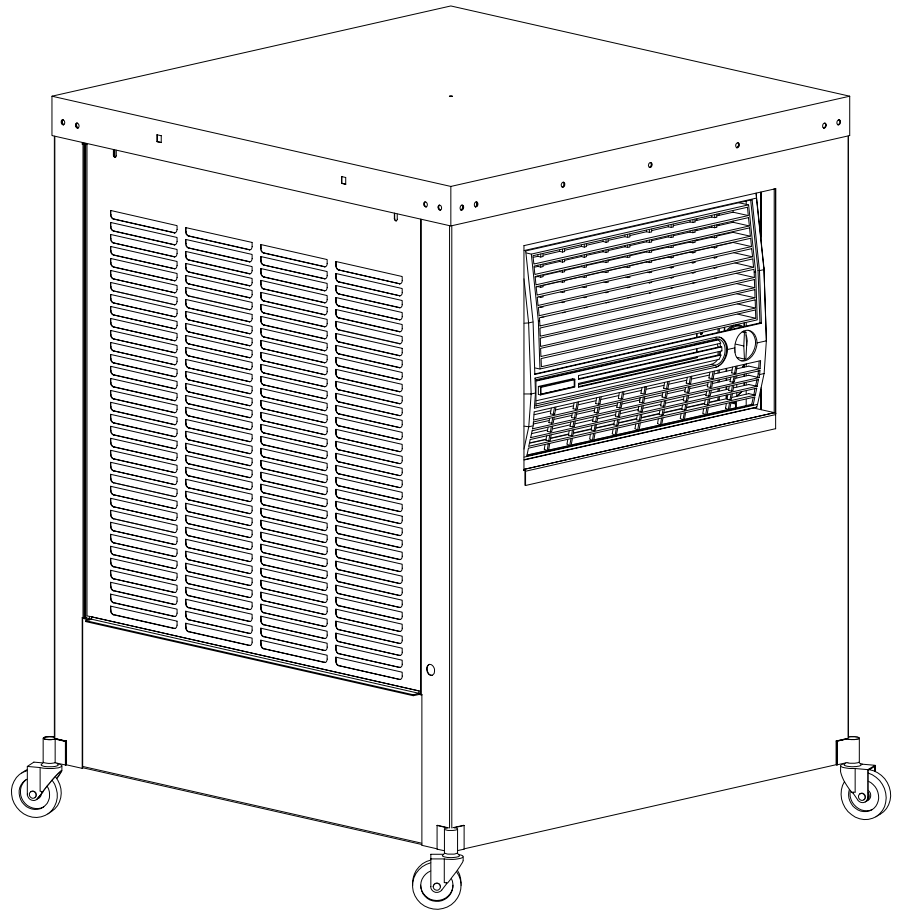

## Evaporative Cooling

Evaporative cooling uses the principle of evaporation to lower the air temperature. Hot, dry air is passed through wetted filters and is converted to refreshingly cooled air. Gadabout Coolers make the best use of the evaporative process by controlling the flow of water, spreading the water evenly over the filters, and delivering a steady stream of cooled air. Gadabout evaporative coolers are 80% less costly to operate than refrigerated air conditioners.

<b>SAFETY GUIDE LINES &amp; CAUTIONS</b>	
<b>When Operating</b>	<b>When Servicing</b>
Make sure that the circuit the cooler is plugged into is equipped with a (slow blow) breaker large enough to support the full amperage of the cooler.	<b>Always Unplug</b> the cooler before attempting service of any kind.
<b>To reduce the risk of fire or electrical shock, <u>DO NOT use this fan with any Solid-state speed control device.</u></b>	If the motor shuts off because of thermal overload, check into the problem immediately. If allowed to continue, permanent damage will occur.
This cooler is equipped with an <u>automatic</u> thermally protected motor. If it shuts off on its own for any reason, <u>it can restart without warning.</u>	Keep cord away from high traffic areas where it may come in contact with a sharp object or be run over by heavy equipment.

### INSTALL DRAIN

1. Slide the Gasket over the Bushing and push through the hole in the cooler pan from the inside. **DO NOT OVERTIGHTEN.**
2. Screw the Cap onto the Bushing and **HAND TIGHTEN.**
3. If leakage occurs after Reservoir is full, retighten the Drain Cap until leaking stops. A small amount of silicone caulk may be used if necessary.

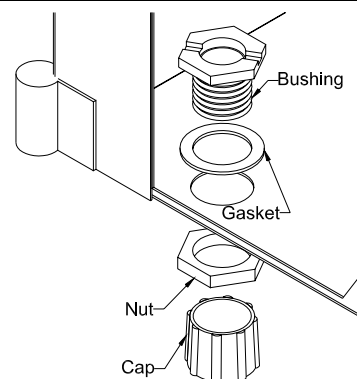

### INSTALL FLOAT

1. Place threaded portion of Float through hole in side of cabinet.
2. Place Washer onto float.
3. Thread Nut onto float, and tighten to secure.
4. Thread Garden Hose Adapter onto float.
5. To adjust float level, loosen Adjustment Screw. Adjust level so float shuts off completely when water level reaches fill line. Retighten screw.

**Note:** The compression nut and ferrule are not required when installing the garden hose adapter.

**Note:** You may fill the cooler by removing one of the louvers and filling the Reservoir directly from a garden hose.

**Note:** If the front panel interferes with the operation of the float, rotate the float bulb slightly to allow proper operation.

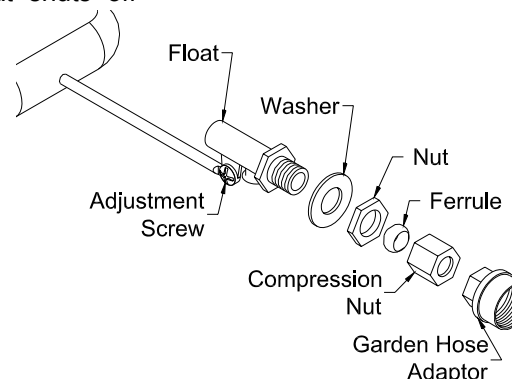

### INSTALL CORD WRAP BRACKETS

The Cord Wrap Brackets attach to the left front corner of the cabinet as shown. Use the 1/4-20 screws and nuts provided.

### INSTALL CASTERS

The Casters slip into the outrigger brackets at the bottom corners of the cabinet as shown.

### OPERATION

1. Place the unit on a level surface near an open door or window.
2. If used inside a building, you should partially open doors and/or windows to ensure adequate exhaust.
3. The cooler may be run on PUMP ONLY, for 2 to 3 minutes before fan operation, to ensure proper wetting of the pads.
4. HIGH and LOW COOL settings operate both the fan and the pump.
5. HIGH and LOW VENT settings operate only the fan.

**Caution:** Do not operate the pump with low or no water in the reservoir.

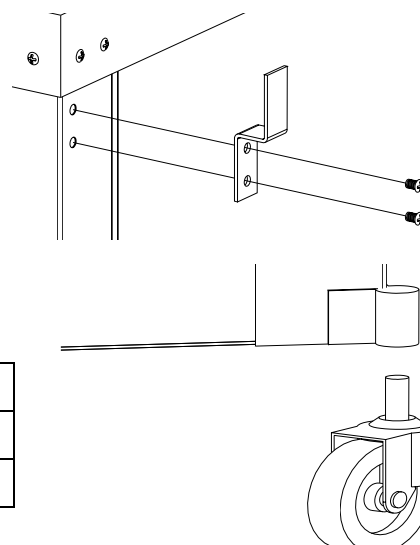

Model	M300	M400	M500
Power consumption	626 watts/hr	551 watts/hr	662 watts/hr
* Cost	4.4 cents/hr	4.0 cents/hr	6.4 cents/hr

\* Based on 7 cents per KWH

**MAINTENANCE**

**NOTE:** This fan motor is thermally protected with an automatic reset and will automatically stop if overloaded. After the motor cools, it will restart automatically. If this occurs, check into the problem before permanent damage occurs.

Periodically inspect your cooler for leaks, proper belt tension and alignment, blocked water lines and excessive residue build-up on the pads.

- To adjust belt tension, loosen the 4 Adjustment Bolts (2 each side) on the Motor Mount. Adjust belt tension so that 3 pounds of pressure (lightly push with one finger) will cause the belt to deflect 3/4", as shown. Retighten the Adjustment Bolts.

Note: The M300 is a direct drive unit. There is no belt.

- Use SAE 20W or SAE 30W non-detergent oil to lube the bearings. Place 2 to 3 drops in the bearing oil cups at the beginning of the season and no more than once a season during cooling season. If the motor has oil holes (usually plugged with yellow caps that read "OIL" at either end of the motor) oil the motor also, following the same procedure as for bearings.

**NOTE:**

- Excessive oil in the bearings may leak out and be drawn into the air stream.
- Excessive oil in the motor may leak onto the motor windings and damage the motor.
- The M300 has no blower bearings, but the motor may be oiled by putting 2 or 3 drops into the small, V shaped protrusion on the side of the motor.

- To replace pads

1. Remove pad frames from cooler.
2. Unhook pad holders and remove.
3. Remove and discard old pads.
4. Clean mineral deposits from the pad frames. If the paint is chipped or rust spots occur, sand the spots and paint with a rust resistant exterior paint.
5. Place new filters in pad frames and tuck in to prevent hot air from bypassing.
6. Replace pad holders and hook into place.
7. Replace pad frames in cooler.

**NOTE:** The M300 has only one pad frame. Two evaporative pads are mounted inside of the cabinet. They are accessible from the pad frame.

- Cleaning cooler

1. Remove the Drain Cap and let the water drain from the reservoir.
2. Rinse dirt and debris from the pan and clean any mineral deposits that may have collected in the reservoir or on any interior surface of the cooler.
3. Clean water trays and ensure that water slots are not clogged.
4. If the paint is chipped or rust spots occur, sand the spots and paint with a rust resistant exterior paint.

**NOTE:** Do not get water on the Fan Motor. This will cause damage.

- Storing cooler

1. Drain water and clean cooler and dry thoroughly.
2. Clean or replace evaporative pads. (Remove pads from pad frames and rinse thoroughly. Allow pads to dry before replacing.)
3. Cover cooler with good quality canvas cover if storing outside (**DO NOT** use plastic). This will protect the finish.

**Always unplug cooler:**

- **Before attempting service of any kind**
- **When not in use**
- **When moving**
- **When filling, if float not used**

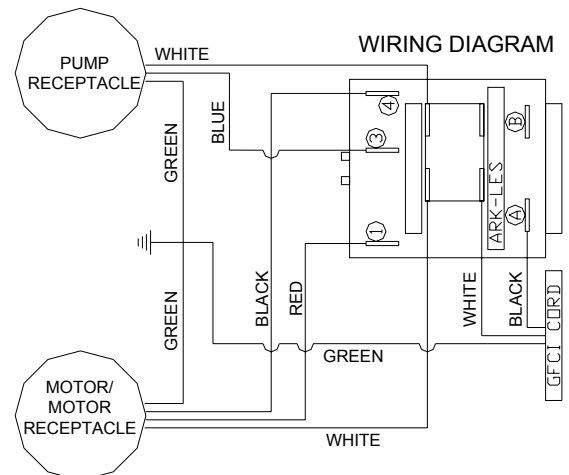
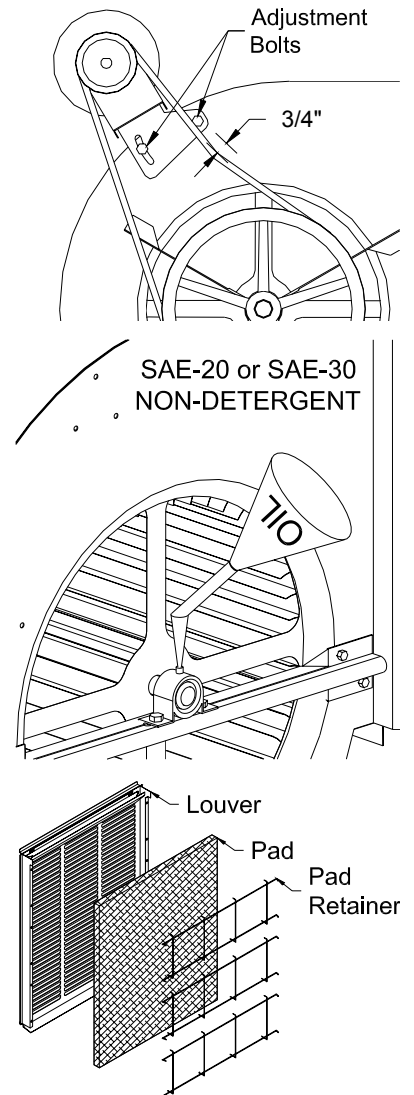

## TROUBLE SHOOTING

PROBLEM	POSSIBLE CAUSE	REMEDY
Cooler fails to start or does not deliver air	No electrical power to unit <ul style="list-style-type: none"> <li>• Fuse blown or breaker tripped</li> <li>• GFCI tripped</li> </ul> Motor overheated Motor locked-up	Check fuses or breakers and GFCI Check voltage and belt tension, replace motor if needed Replace motor
Motor cycles on and off	Low voltage	Check voltage, plug into different outlet if needed
Excessive humidity	Insufficient exhaust	Open doors or windows
Inadequate air delivery	Insufficient exhaust Pads plugged	Clean or replace pads
Inadequate cooling	Insufficient exhaust Pads not wet <ul style="list-style-type: none"> <li>• Pads plugged</li> <li>• Water distributor clogged</li> <li>• Pump malfunction</li> <li>• Water trays clogged</li> </ul>	Open doors or windows Check water distributor system <ul style="list-style-type: none"> <li>• Clean or replace pads</li> <li>• Clean water distributor</li> <li>• Clean or replace pump</li> <li>• Clean water trays</li> </ul>
Musty or unpleasant odor	Stale water in cooler Pads mildewed or plugged	Drain and clean pan Clean or replace pads
Noisy	Fan rubbing housing Loose parts	Realign blower wheel ( <b>unplug unit</b> ) Tighten loose parts
Cooler pan overflowing	Float improperly adjusted	Adjust float

## LIMITED WARRANTY

**This warranty is extended to the original purchaser only.** It does not cover damages incurred during shipping or through accident, neglect, or abuse by the owner. Tradewinds does not authorize any person or representative to assume any other or different liability in connection with this cooler.

### TERMS AND CONDITIONS OF WARRANTY

The **CABINET** is guaranteed against leakage due to rusting out for **Five Years**. All other original parts provided by Tradewinds are warranted against defects in material or factory workmanship for Two Years.

### EXCLUSIONS FROM THE WARRANTY

Tradewinds is not responsible for incidental or consequential damage resulting from any malfunction.

Tradewinds is not responsible for any damage occurring from the use of water softeners, chemicals, descale material, or if a higher horsepower motor than what Tradewinds recommends is used in the unit.

Tradewinds is not responsible for the cost of service calls to diagnose cause of trouble, or labor charge to repair and/or replace parts.

### HOW TO OBTAIN SERVICE UNDER THIS WARRANTY

Contact the Dealer where you purchased the evaporative cooler. If for any reason you are not satisfied with the response from the Dealer, contact Customer Service Department: Tradewinds 5800 Murray Street, Little Rock, Arkansas 72209. 1-501-562-1094. [www.tradewindsc cooler.com](http://www.tradewindsc cooler.com).

When contacting Customer Service, please have the following information available.

Purchase Date: \_\_\_\_\_

Model Number: \_\_\_\_\_

Serial Number: \_\_\_\_\_

## M400 & M500 REPLACEMENT PARTS

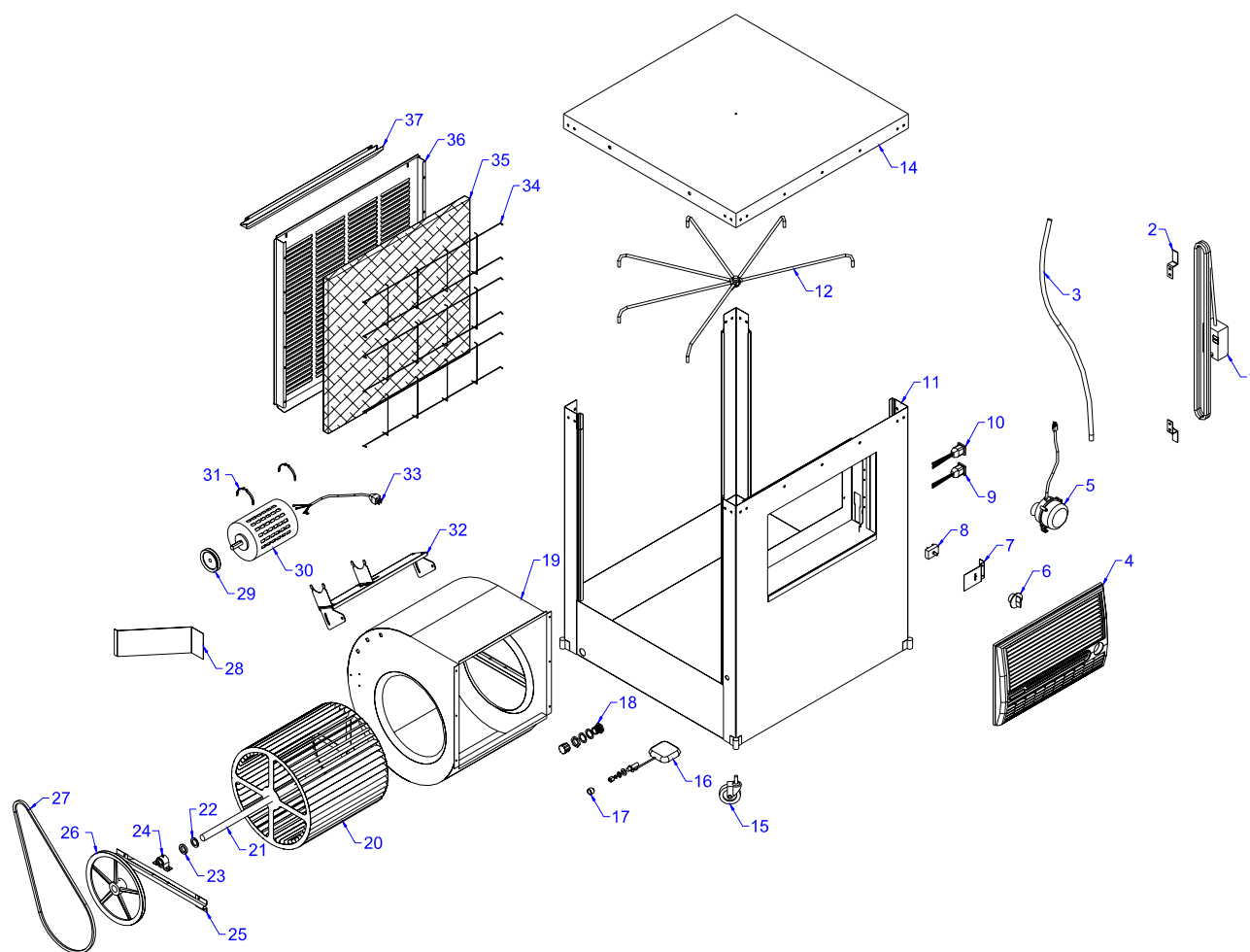

Item	M400 Part No.	M500 Part No.	Description	Item	M400 Part No.	M500 Part No.	Description
1	71014	71014	Power cord	20	30318	30322	Blower wheel
2	71033	71033	Cord wrap bracket	21	30241	30238-02	Shaft
3	70973	71027	Water hose	22	524330	524331	Set collar
4	71130	71130	Grill assembly	23	501244	501241	Fiber washer
5	71012	71030	Pump	24	583000	60PB	Bearing
6	71129	71129	Knob	25	70925	70924	Bearing support
7	70982	70982	Switch bracket	26	583009	583091	Blower pulley
8	524299	524299	Switch	27	582093	582030	Belt
9	595121T	595121T	Pump receptacle	28	71025	70955	Blower brace
10	595098T	595098T	Motor receptacle	29	325FP	325FP	Motor pulley
11	70965	71000	Cabinet	30	50310	30491	Motor
12	70967	70968	Water distributor	31	524162	524162	Motor clamps
14	70959	70958	Top	32	515160	70154	Motor support
15	71019	71019	Caster	33	595129	595129	Motor cord
16	524198	524198	Float	34	504254	504256	Pad retainer
17	71021	71021	Garden hose adapter	35	71103	71104	Pad
18	70980	70980	Drain assembly	36	70957	70956	Pad frame
19	70972	71026	Blower housing	37	504267	504269	Water tray

### M300 REPLACEMENT PARTS

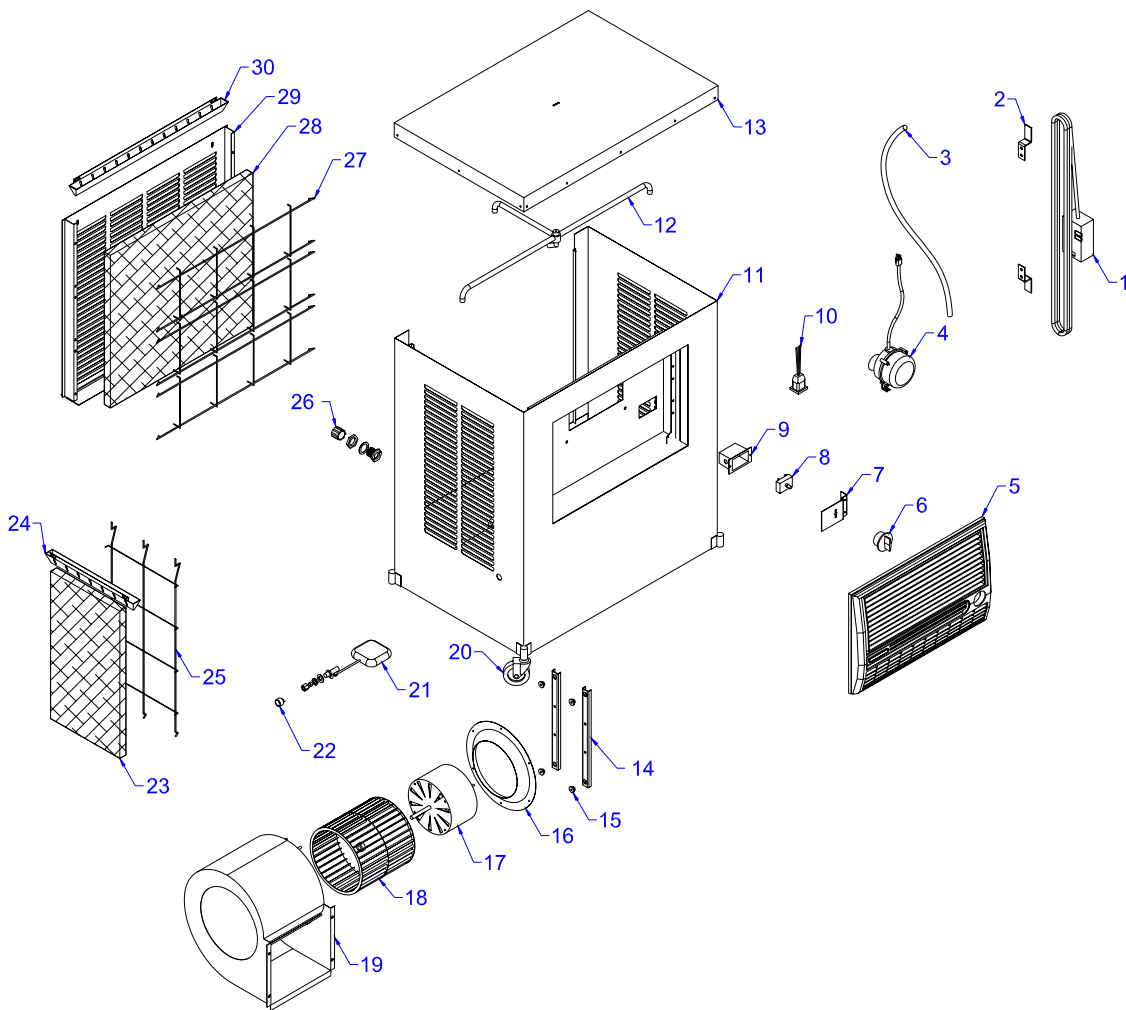

Item	M300 Part No.	Description	Item	M300 Part No.	Description
1	71014	Power cord	16	70425	Inlet ring
2	71033	Cord wrap bracket	17	70423	Motor
3	70973	Water hose	18	70424	Blower wheel
4	71012	Pump	19	70367	Blower housing
5	71130	Grill assembly	20	71019	Caster
6	71129	Knob	21	524198	Float
7	70982	Switch bracket	22	71021	Garden hose adapter
8	524299	Switch	23	71052	Pad (side)
9	524342	Switch box	24	504266	Tray (side)
10	595121T	Pump receptacle	25	70415	Pad retainer (side)
11	71006	Cabinet	26	70980	Drain assembly
12	71100	Water distributor	27	504255	Pad retainer (back)
13	70987	Top	28	71053	Pad (back)
14	70431	Motor mount	29	70375	Pad frame
15	589040	Rubber bushing	30	504268	Water tray (back)