

This Owner's Manual is provided and hosted by [Appliance Factory Parts](#).

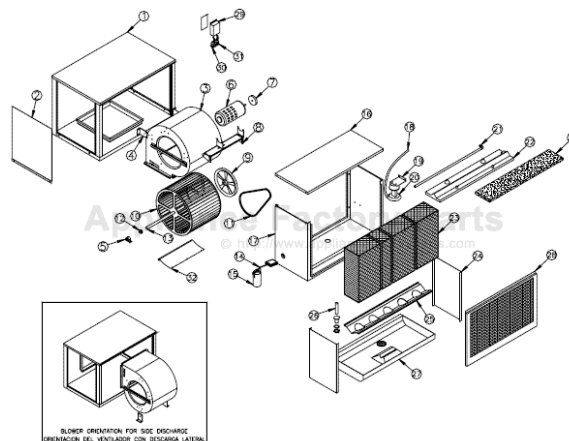

ESSICK SI500D12 Owner's Manual

[Shop genuine replacement parts for ESSICK SI500D12](#)



[Find Your ESSICK Evaporative Cooler Parts - Select From 70 Models](#)

----- Manual continues below -----



ESSICKAIR
The Cool One

**Owner's Manual
Model #'s**

SI-500S , SI-500D

SI-700D , SI-700S

SI-500S12 , SI-500D12

SI-700S12 , SI-700D12

**Read & Save This
Instruction Manual!**

SINGLE INLET
Horizontal And Down Discharge
Evaporative
Air Cooler

Our Mission:

**We Will Respond to Our Customers With High Quality Products
and Service, While Eliminating Waste From Our Processes.**

Evaporative Cooling

Evaporative cooling uses the principle of evaporation to lower the air temperature. Hot, dry air is passed through wetted filters and is converted to refreshingly cooled air. Essick Coolers make the best use of the evaporative process by controlling the flow of water, spreading the water evenly over the filters, and keeping a steady stream of cooled air entering your home. It is exhausted out open windows or doors, carrying heat, smoke and odors along with it. Essick evaporative coolers are 80% less costly to operate than refrigerated air conditioners.

Cautions: To prevent harm to yourself and others, and to avoid damage to your cooler, PLEASE follow these guidelines.

SAFETY GUIDE LINES & CAUTIONS		
When Installing	When Operating	When Servicing
Make sure that unit is installed on a sound structure that will support the full operating weight of the cooler. See page 5.	Make sure that cooler circuit is equipped with a (slow blow) breaker large enough to support the full amperage of the cooler.	Be sure to disconnect unit from power source before servicing. If not, it can be turned on from inside the house and start unexpectedly.
Before attempting to transport cooler to the roof. Separate fan section from wet section to reduce weight. Always plan a safe method of transporting cooler to installation site without damage to the cooler or injury to yourself.	<u>To reduce the risk of fire or electrical shock, DO NOT use this fan with any Solid-state speed control device.</u>	Never drain water onto your roof. Water residue could cause you to slip or may stain your roof.
Do Not connect power to cooler before installation is complete.	This cooler is equipped with an <u>automatic</u> thermally protected motor. If it shuts off on its own for any reason, <u>it can restart without warning.</u>	If the motor shuts off because of thermal overload, check into the problem immediately. If allowed to continue, permanent damage will occur.
Wear gloves and protective eyewear when installing or servicing.		

Tools and supplies needed for installation

- Pliers
- Screwdrivers
- Adjustable wrenches
- Tubing cutter
- 5/32 hex key wrench
- Level
- Electric drill
- Drill bits
- Hammer
- Duct tape
- Caulk
- Sheet metal screws
- ECR-6 wall switch
- Safety glasses
- Wiring supplies – It is recommended that a licensed electrician do all electrical work.
- Ductwork – A local sheet metal shop can supply ductwork.
- 1/4" water line
- Saddle valve or faucet adapter
- Roof stand (if cooler is roof mounted)
- Roof flashing and pitch

Mounting

1. Prepare duct to fit model used (500 series coolers 17 3/4" square; 700 series 19 3/4" square).
2. Cut opening in wall or roof to fit duct. If wall studs or roof joists are cut, reinforce them.
3. Mount the duct in the opening. The duct will fit inside the cooler opening. The duct length from roof to bottom of cooler should be a minimum of 4" at the closest point, so there is access to the water drain.
4. Install flashing around roof opening to prevent water entry. Use pitch to seal the seams.
5. Measure cooler and layout mounting location.
6. Mount cooler to stand or pad. Cooler must be level front to back and left to right. Note: It is best that the fan section end of the cooler face up the roof to achieve a lower profile and allow better access to the drain.
7. Be sure to securely fasten all four corners of cooler to stand or pad.
8. Caulk duct to the cooler to prevent air leakage.

Motor mounting

Warning: Do Not energize the cooler until the installation is complete.

1. Place the motor into the cradles. Be sure that the cradles fit into the groove in the motor grommets.
2. Secure with the saddle clamps provided in the installation package. **DO NOT OVERTIGHTEN.**

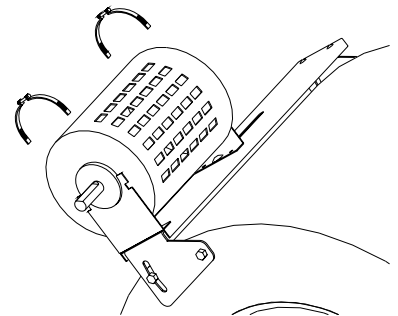

Electrical connections

CAUTION: Disconnect all electrical power at the breaker or fuse box before you begin to install or service any cooler.

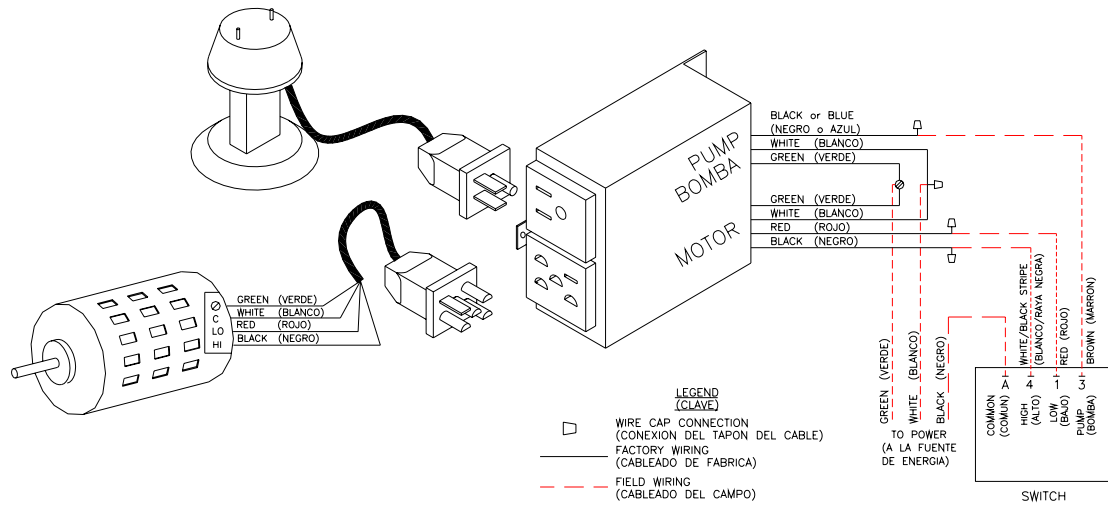

- Wiring for this cooler must comply with any and all applicable codes. It is recommended that a licensed electrician install any required wiring.
- To remotely operate this unit, use an ECR-6 switch. It is equipped with 2 cooling positions, 2 vent positions and a pump only position to wash or pre-wet the pads.
- The junction box mounts in the corner post of the fan section. Receptacles are provided for the motor and pump.
- All wiring connections must be made inside the junction box. See wiring diagram below.

Motor pulley installation

1. Loosen both set screws on the pulley. Use 5/32" hex key Allen wrench.
2. Slide the pulley onto the motor shaft with the threaded side out.
3. Install the belt and align the motor pulley and blower pulley.
4. Align the set screw on the motor side of the pulley with the flat portion of the motor shaft and tighten.

Motor pulley adjustment

1. Turn the outside jaw of the motor pulley clockwise until the pulley is fully closed.
2. Align the outside set screw with the nearest flat spot on the threaded portion of the pulley. This is the zero position.
3. Turn the outside jaw of the pulley counterclockwise 3 full turns. Align set screw with a flat on the threaded portion of the pulley and tighten. This step will ensure that your cooler will run without overloading the motor. Further adjustment may be required.

Warning: if set screw is tightened onto threads, damage will occur and pulley will no longer be able to be adjusted.

When the installation is complete and all panels are in place, check the motor amperage using clamp-on type ammeter. Since all the cooler access panels must be in place to get a true reading, check amperage at a disconnect box, breaker or fuse box.

4. Find out the amperage from the motor nameplate.
5. Clamp ammeter around the incoming white lead.
6. Start the cooler on HI VENT.
7. If amperage is less than motor nameplate rating, loosen the outer set screw of motor pulley, then turn the outer jaw of the pulley clockwise ½ turn and tighten the outer set screw. Recheck the amperage and repeat step if necessary.
8. If amperage is more than motor nameplate rating, loosen the outer set screw of motor pulley, then turn the outer jaw of the pulley counterclockwise ½ turn and tighten the outer set screw. Recheck the amperage and repeat step if necessary.
9. Proper belt tension is crucial to efficient operation and motor and belt life. See the maintenance section for instructions on achieving proper belt tension.

Install overflow and drain

1. Slide rubber washer onto drain bushing and place through hole in reservoir from the top side.
2. Secure it from below with the lock nut. Make sure rubber washer does not twist while tightening, which could cause it to leak. Hand tighten first and then tighten 3/4 turn further with proper tool. **Do not over tighten.**
3. Thread the plastic overflow tube into the drain bushing and hand tighten until snug.

Note: If leakage occurs after reservoir is filled, further snug the fitting until leakage stops. Plumber's tape or thread putty may be used if necessary.

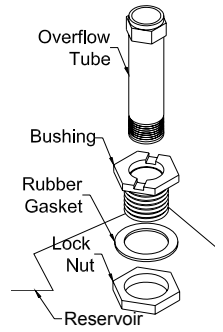

Float valve installation

1. Place the threaded portion of the Float Valve through the hole provided in the Corner Post from the inside.
2. Slip the Fiber Washer over the threaded portion outside the corner post and secure with the Nut. Be sure the Float does not turn while you are tightening the Nut.
3. Slip the Float Tube onto the float so that the key hole is just behind the water inlet and the float rod is able to move up and down freely. The object is to contain any spray.

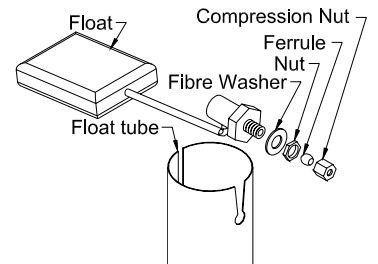

Water line connection

1. Find the closest outside water faucet, and install a Water Connection Kit (not included with cooler) as shown. If an exterior faucet is not available, locate the closest cold water pipe and install a saddle valve assembly.
2. Route tubing to cooler. Place Compression Nut and Ferrule over end of tubing. Insert the tubing into float valve and tighten Compression Nut to secure.

Note: Tightening a compression fitting will cause that fitting to leak. It is best to secure the connections, turn on the water, and then snug the fitting until leaking stops.

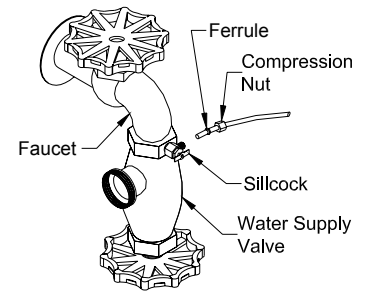

Adjusting water level and float

In order for the float to shutoff the flow of water at the desired level, you must adjust the float.

1. Fill reservoir to 1/2" below top of overflow tube.
2. Bend float rod down, slightly, until adequate pressure is achieved and float shuts off completely.

Note: Never use "soft water" from water softening equipment. This water is very corrosive and will cause damage to your cooler. Using a water softener in conjunction with this cooler will void the warranty. Use of caustic cleaners or other harsh chemicals will also void the warranty.

Start-up inspection

Before starting the cooler, make sure all installations are correct. Be sure that:

1. Cooler is grounded and electrical connections are safe and secure.
2. Cooler is level and duct is sealed
3. Blower wheel does not rub the housing.
4. Water supply is turned on.
5. Drain fitting and water connections are secure and do not leak.
6. Float is adjusted to the proper level.
7. **Important:** motor pulley is set at the correct diameter. If not, motor can overheat and fail.
8. Belt tension is OK.
9. Pulley alignment is OK.
10. Check switch for proper operation.

ECR-6 switch operation		
Switch setting	Blower motor	Pump
Off	Off	Off
Pump Only	Off	On
Low Vent	Low	Off
High Vent	High	Off
Low Cool	Low	On
High Cool	high	On

Trouble shooting

Problem	Cause	Solution
Motor cycles on and off	Motor pulley set too large Excessive belt tension Blower shat frozen	Adjust motor pulley Adjust belt tension Lubricate or replace bearings
Water draining from overflow	Float improperly adjusted Lime build up in float valve	Adjust float Clean or replace float
Blower shakes	Belt or pulley loose	Adjust or tighten
Fails to start	No electrical power Blown fuse or popped circuit breaker	Check power Replace or reset
Not cooling	Water supply turned off Blocked water distributor	Check water supply Clean distributor

Maintenance

Caution: turn off all electrical power to the cooler before opening or attempting service of any kind

The motor is equipped with automatic thermal protection. If it shuts off for any reason, it can start back up without warning!

Occasionally inspect your cooler for leaks, loose belt, blocked water lines, correct belt alignment or excessive residue build up on the pads.

Belt tension

At the proper tension, the belt will deflect 1/2" to 3/4" when 3 to 5 pounds of pressure is applied to the belt approximately half way between the blower and motor pulleys. Adjust the belt tension using the motor bracket do not change the diameter of the pulley in order to adjust the belt tension.

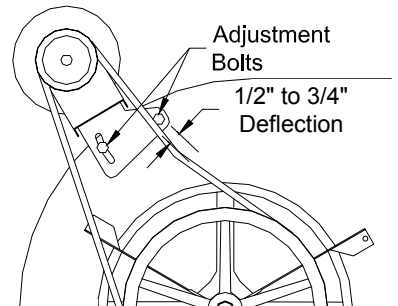

Lubrication

Lube the oil cups on the blower bearing. Use SAE20 or SAE30 Non-Detergent oil. Oil the blower motor only if oil holes exist.

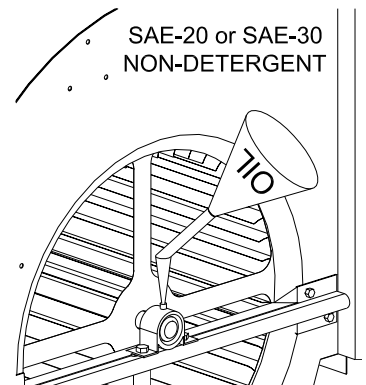

End of season

1. Drain and clean the reservoir. Do not get water on the blower motor or pump motor.
2. Remove the belt and hang it from the motor pulley.
3. Remove the pads and clean carefully.
4. Remove water distributor and hose out with garden hose. Use a small nail to clean any deposits from the water holes.

Pad Replacement

Lime build up can occur in the water reservoir and on the pads. Clean this off at least once per season. If any rust or bare metal spots occur on the cabinet, the metal should be sanded, primed and painted with good quality paint.

1. Remove wet section top.
2. Remove water distributor assembly.
3. Remove and discard old pads.
4. Install new pad set. Refer to diagram below or pad installation instructions for correct orientation.
5. Ensure that water distributor pad is centered over cooler pads.
6. Carefully replace water distributor; ensure pads are not damaged while replacing assembly.
7. Replace wet section top.

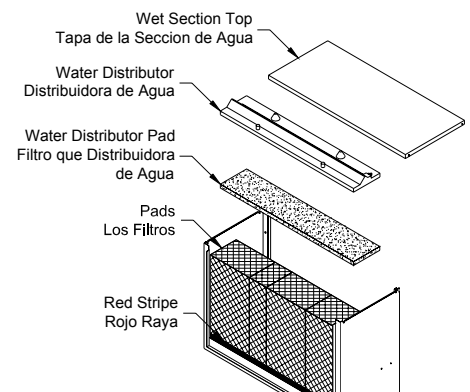

Model	Weight	
	Dry	Operating
SI500-S	153	224
SI500-D	153	224
SI700-S	184	255
SI700-D	184	255

Replacement Parts

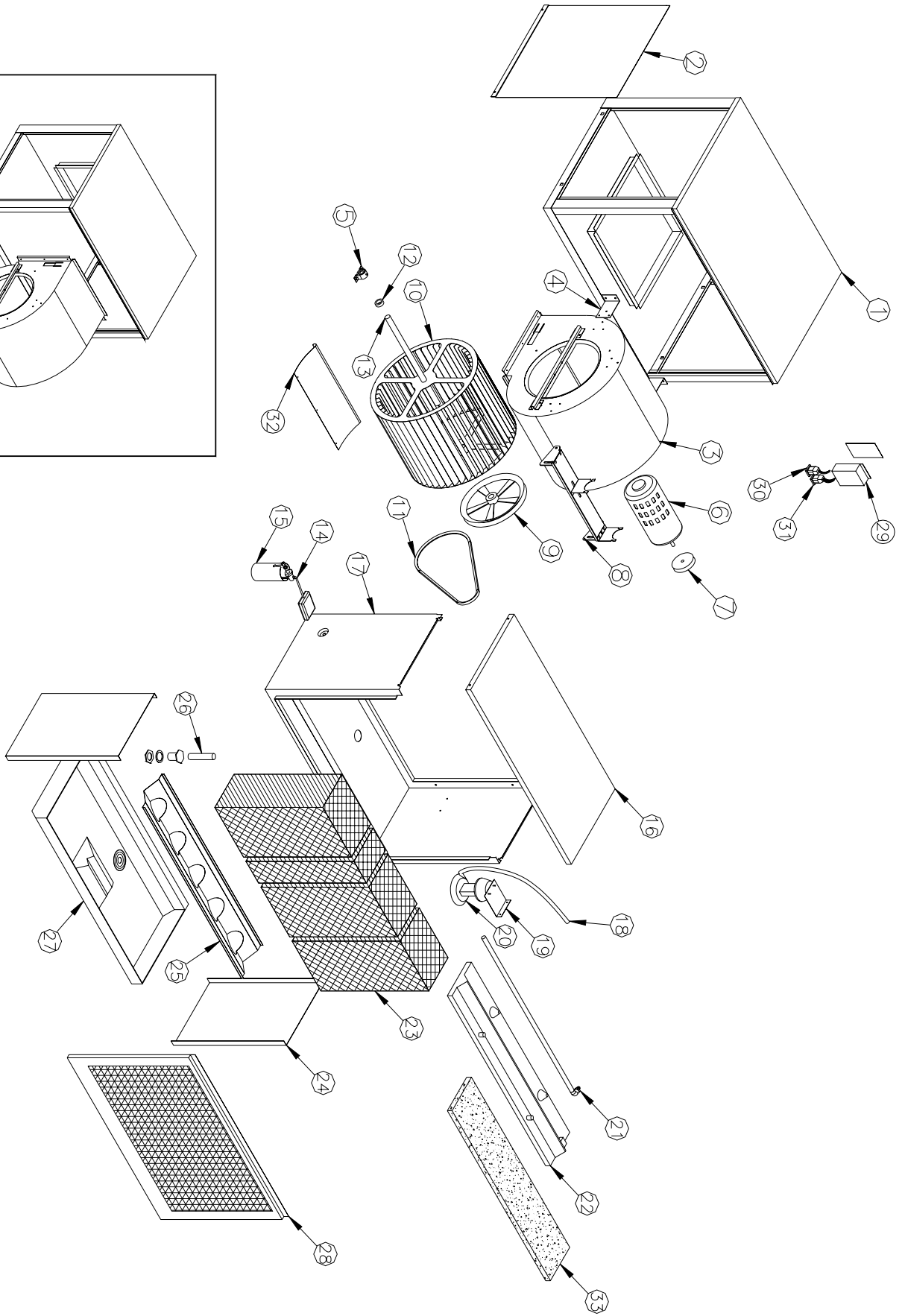
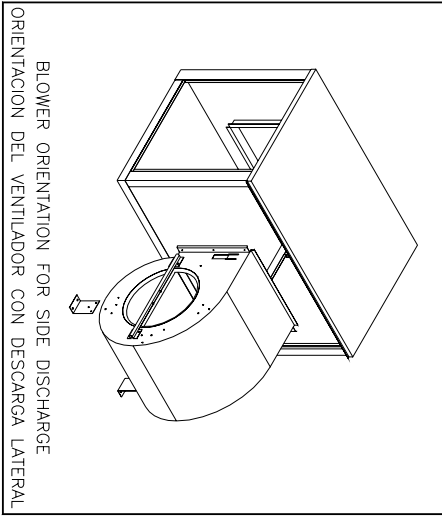

No.	Description	Descripción	Qty	SI500S	SI500D	SI700S	SI700D
1	Fan section	Seccion del abanico	1	70018	70001	70023	70038
2	Access Panel	Panel de acceso	2	70005	70005	70027	70027
3	Blower Housing	Caja del ventilador	1	70021	70014	70034	70040
4	Blower Brace	Conjnette del ventilador	2	70151	70045	70151	70045
5	Blower bearing	Abrazadera del ventilador	2	30289	30289	30288	30288
6	Motor	Motor	1	***	***	***	***
7	Motor pulley	Polea del motor	1	70170	70170	583041	583041
8	Motor mount	Montaje del motor	1	70154	70154	70125	70125
9	Blower Pulley	Polea del ventilador	1	583013	583013	30314	30314
10	Blower wheel	Rueda del ventilador	1	30322	30322	70120	70120
11	Blower belt	Banda del ventilador	1	582090	582009	4L690	582001
12	Set collar	Collar fijo	1	524331	524331	524331	524331
13	Blower shaft	Eje del ventilador	1	30238-02	30238-02	30238-01	30238-01
14	Float valve	Valvula flotadora	1	524198	524198	524198	524198
15	Float tube	Tubo flotador	1	70132	70132	70132	70132
16*	Wet section top	Tapa de seccion del agua	1	70009	70009	70009	70009
17*	Wet section housing	Estructura de la seccion de agua	1	70006	70006	70028	70028
18	Water hose	Manguera del agua	1	70196	70196	70197	70197
19	Pump bracket	Abrazadera de la bomba	1	70067	70067	70067	70067
20	Pump	Bomba	1	506674	506674	506674	506674
21	Water distributor tube	Tubo del distribuidor del agua	1	70116	70116	70116	70116
22*	Water distributor	Distribuidor del agua	1	70043	70043	70043	70043
23*	Pad media set	Juego de filtros	1	70054	70054	70055	70055
24*	Water shield set	Juego de protectores del agua	1	70095	70095	70098	70098
25*	Pad support tray	Bandeja para sostenerlos filtros	1	70010	70010	70010	70010
26	Overflow kit	Equipo de desbordamiento	1	70613	70613	70613	70613
27*	Reservoir	Deposito	1	70053	70053	70053	70053
28	Inlet Screen	Alambrera	1	70012	70012	70031	70031
29	Electrical junction box	Caja de union electrica	1	70130	70130	70130	70130
30	Motor plug	Enchufe del motor	1	595098	595098	595098	595098
31	Pump plug	Enchufe de la bomba	1	595121	595121	595121	595121
32	Blower cutoff	Tapon de la caja del ventilador	1	504280	504280	70124	70124
33	Water distributor pad	Filtros del distribuidor del agua	1	70155	70155	70155	70155

*** Speak with Essick Air Products representative for specific motor requirements.

***For units with 12" media, refer to table below for Wet Section parts.**

No.	Description	Descripción	Qty	SI500S-12	SI500D-12	SI700S-12	SI700D-12
16*	Wet section top	Tapa de seccion del agua	1	70877	70877	70877	70877
17*	Wet section housing	Estructura de la seccion de agua	1	70907	70907	70879	70879
22*	Water distributor	Distribuidor del agua	1	70872	70872	70872	70872
23*	Pad media set	Juego de filtros	1	70912	70912	70875	70875
24*	Water shield	Juego de protectores del agua	2	70909	70909	70874	70874
25*	Pad support tray	Bandeja para sostenerlos filtros	1	70887	70887	70887	70887
27*	Reservoir	Deposito	1	70871	70871	70871	70871

Limited Warranty

This warranty is extended to the original purchaser only of an evaporative cooler installed and used under normal conditions. It does not cover damages incurred during shipping or through accident, neglect, or abuse by the owner. Essick Air Products does not authorize any person or representative to assume any other or different liability in connection with this product.

Terms and conditions of warranty

This warranty includes lifetime limited coverage on water reservoir against any leakage due to defects in material. From date of installation, if any original component part provided by Essick Air Products fails due to defect in material or factory workmanship only, Essick Air Products will provide the replacement parts as follows:

- Cabinet components for one year from date of installation
- Evaporative media for five years from date of installation

Exclusions from this warranty

- Essick Air Products is not responsible for incidental or consequential damage resulting from any malfunction.
- Essick Air Products is not responsible for any damage occurring from the use of water softeners, chemicals, descale material, or if a higher horsepower motor than what Essick Air Products recommends is used in the unit.
- Essick Air Products is not responsible for the cost of service calls to diagnose cause of trouble, or labor charge to repair and/or replace parts.

How to obtain service under this warranty

Contact the Dealer where you purchased the evaporative cooler. If for any reason you are not satisfied with the response for the Dealer, contact Customer Service Department: Essick Air Products Inc. 5800 Murray Street, Little Rock, Arkansas 72209. 1-800-643-8341.