

This Owner's Manual is provided and hosted by [Appliance Factory Parts](#).



Smoke Hollow 34167G Owner's Manual

[Shop genuine replacement parts for Smoke Hollow
34167G](#)



[Find Your Smoke Hollow Grill Parts - Select From 115 Models](#)

----- Manual continues below part list -----

Available Replacement Parts for Smoke Hollow 34167G

3803006	Hose-Valve-Regulator Assy
CG3430	COOKING GRID
SC3430	COVER SMOKE HOLLOW



Assembly & Operation

30167G/34167G
34166GC/38207G
Gas Smoker

DANGER

FOR YOUR SAFETY - IF YOU SMELL GAS:

1. SHUT OFF GAS TO THE APPLIANCE.
2. OPEN SMOKER DOOR.
3. EXTINGUISH ANY OPEN FLAME.
4. PERFORM A GAS LEAK TEST.
5. IF ODOR CONTINUES, KEEP AWAY FROM THE APPLIANCE AND IMMEDIATELY CALL YOUR FIRE DEPARTMENT.

FAILURE TO FOLLOW THESE INSTRUCTIONS AND WARNINGS COULD RESULT IN FIRE OR EXPLOSION, WHICH COULD CAUSE PROPERTY DAMAGE, PERSONAL INJURY OR DEATH.

DANGER

1. Never operate this appliance unattended.
2. Never operate this appliance within 10 feet (3.05 m) of any other gas cylinder.
3. Never operate this appliance within 25 feet (7.5 m) of any flammable liquid.
4. Heated liquids remain at scalding temperatures long after the cooking process. Never touch cooking appliance until liquids have cooled to 115°F (45°C) or less.
5. If a fire should occur, keep away from the appliance and immediately call your fire department. Do not attempt to extinguish an oil or grease fire with water.

Failure to follow these instructions could result in fire, explosion or burn hazard, which could cause property damage, personal injury or death.

DANGER

This instruction manual contains important information necessary for the proper assembly and safe use of the appliance.

Read and follow all warnings and instructions before assembling and using the appliance.

Follow all warnings and instructions when using the appliance.

Keep this manual for future reference.

Installer - leave the manual with the consumer.



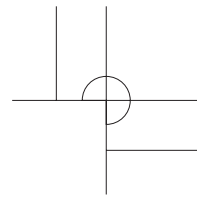
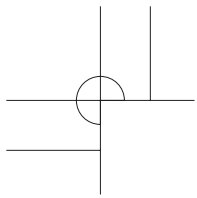



Outdoor Leisure Products, Inc.
5400 Doniphan Drive
Neosho, MO 64850

Toll Free: 866-475-5180

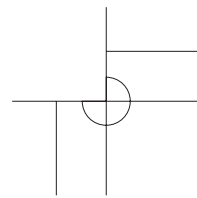
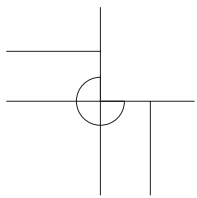
8:30am to 4:30pm, Central Time
Monday through Friday



READ ALL SAFEGUARDS AND INSTRUCTIONS THOROUGHLY!
 YOUR SAFETY IS VERY IMPORTANT - FAILURE TO FOLLOW PROPER PROCEDURES AND SAFEGUARDS
 MAY RESULT IN PROPERTY DAMAGE, PERSONAL INJURY OR DEATH.

 DANGER	 DANGER
<ul style="list-style-type: none"> · This smoker is for OUTDOOR USE ONLY. · Never operate this smoker unattended. · The use of alcohol, prescription or non prescription drugs may impair the consumer's ability to properly assemble or safely operate the smoker. · Never operate this smoker within 10 feet (3m) of any gas cylinder. Never operate this smoker within 25 feet (7.5 m) of any flammable liquids. · Use this smoker only on a level, stable non-combustible surface like brick, concrete or dirt. Do not use smoker on or around any surface that will burn or melt like wood decks, dry grass, leaves, wood rails, asphalt, vinyl, or plastic. · Never operate this smoker under any overhead roof covering, awning or overhang. Never use inside an enclosed area such as screen patios, garage, buildings, tents. Keep a minimum clearance of 10 feet (3m) from all sides of the smoker to all overhead construction and 3 feet or 1m to any walls or rails. · Never use in or on recreational vehicles and/or boats. · Never use this product for anything other than its intended purposes. This smoker is not intended for commercial use. Never use this smoker as a heater. · Keep the area clear of all flammable liquids, combustible material including but not limited to wood, dry plants including grass, brush, paper, and canvas. · Smoker is HOT while in use and after use - Avoid touching hot surfaces. Always wear protective gloves or mitts when operating the smoker. · Keep children and pets away from the smoker at all times. · Do not allow anyone to conduct activities around the smoker during or following its use until the unit has cooled. The smoker is hot during operation and remains hot for a period of time following its use. · Never move the smoker when it is in use. Allow the smoker to cool below 115°F (40°C) before moving or storing it. · Always wear shoes and protective clothing during operation of this smoker. 	<ul style="list-style-type: none"> · Accessory attachments and cookware not manufactured or supplied by Smoke Hollow for this smoker are not recommended for use. · Perform a leak test before each use of the smoker. (See page 18) · Keep the fuel supply hose away from any heated surfaces. · Never attach a gas cylinder, move or alter fittings when the smoker is hot or in use. · Do not attempt to disconnect any gas fitting while the smoker is in operation. · Never fill the cylinder beyond 80 percent full. Overfilled cylinders can release gas. · Never use a gas cylinder if it appears to have dents, gouges, bulges, fire damage, erosion, leakage, excessive rust, or other forms of visible external damage. The cylinder may be hazardous and should be checked by a liquid propane supplier. · The LP-gas cylinder being used must be constructed and marked in accordance with the specifications for LP-gas cylinders of the U.S. Department of Transportation (DOT) CFR 49 or the National Standards of Canada, CAN/CSA-B339, Cylinders, Spheres and Tubes for the Transportation of Dangerous Goods. · The installation of this smoker must conform with local codes or, in the absence of local codes, with the National Fuel Gas Code, ANSI Z223.1, Storage and Handling of Liquefied Petroleum Gases, ANSI/NFPA 58 or CSA B149.1, Natural Gas Installation Code or CAN/CGA-B149.2, Propane Installation Code. · Before each use, inspect gas hose for any signs of damage and check all nuts and bolts to be sure that they are tight and secure. · When lighting your smoker, do not cover the burner or restrict airflow from the burner. An explosion could occur. · If burner does not ignite, turn off the control valve and gas and wait 5 minutes before trying to light it again. If the burner goes out during operation, first turn the control valve OFF, then the gas cylinder OFF.

READ ALL SAFEGUARDS AND INSTRUCTIONS THOROUGHLY!
YOUR SAFETY IS VERY IMPORTANT - FAILURE TO FOLLOW PROPER PROCEDURES AND SAFEGUARDS
MAY RESULT IN PROPERTY DAMAGE, PERSONAL INJURY OR DEATH.

⚠ DANGER	⚠ DANGER
<ul style="list-style-type: none">· Do not obstruct flow of combustion and ventilation. Keep the ventilation opening(s) of the cylinder enclosure free and clear of debris.· Keep clear of the smoker hose. Tripping over the smoker hose may result in the spilling of HOT grease or water, causing personal injury or property damage.· In the event of an oil/grease fire, immediately turn off gas supply and call the Fire Department. Do not attempt to extinguish a fire with water. A Type BC or ABC fire extinguisher may in some cases contain the fire.· Keep your hands, hair and face away from the burner flame. Do not lean over or into the smoker when lighting the burner. This smoker has an open flame. Be careful of loose hair and clothing during operation which could catch fire.· After use, always turn the control valve OFF first, then the gas cylinder valve OFF.	<ul style="list-style-type: none">· Always allow the hot water to cool completely below 100° F (38°C) before moving to avoid the possibility of severe burns.· Never use glassware, plastic, or ceramic cookware in this smoker.· Always disconnect the gas cylinder from your smoker when not in use.· Do not store a spare LP-gas cylinder under or near smoker. The gas cylinder safety relief valve may overheat, allowing gas to release causing and intense fire causing death or serious injury.· Cylinders must be stored outdoors, out of reach of children, and must not be stored in a building, garage, or any other enclosed area.· If you smell, hear or see gas escaping, immediately get away from the gas cylinder and call the Fire Department.

USE CAUTION AND COMMON SENSE WHEN OPERATING YOUR SMOKER. READ ALL INSTRUCTIONS, WARNINGS AND SAFEGUARDS PRIOR TO ASSEMBLING AND OPERATING YOUR SMOKER.

SAVE THESE INSTRUCTIONS



Parts list for 34167G

Before Assembly

Read all safeguards and assembly instructions before assembling and operating your smoker.

Before assembling your new smoker, unpack all the parts from the box. Carefully remove all packing material and lay out all the parts for easy access and identification. Do not discard the carton or packaging until your smoker is fully assembled and operating to your satisfaction.

In order to properly assemble your smoker, you will only need two tools:

- Phillips head screwdriver
- Pliers or 3/8" & 7/16" wrench

(tools not included)

Be sure to have a friend help. The smoker is heavy and must be moved around during assembly and before use.

To use your smoker immediately after assembly, have an L.P. gas cylinder filled by an authorized L.P. dealer or cylinder exchange center. Also, be sure to have your choice of flavoring wood readily available.

(L.P. Gas Cylinder and Flavoring Wood is not included)

For further assistance, including missing or damaged parts, call toll free: 866-475-5180 8:30am to 4:30pm, Central Time, Monday - Friday.

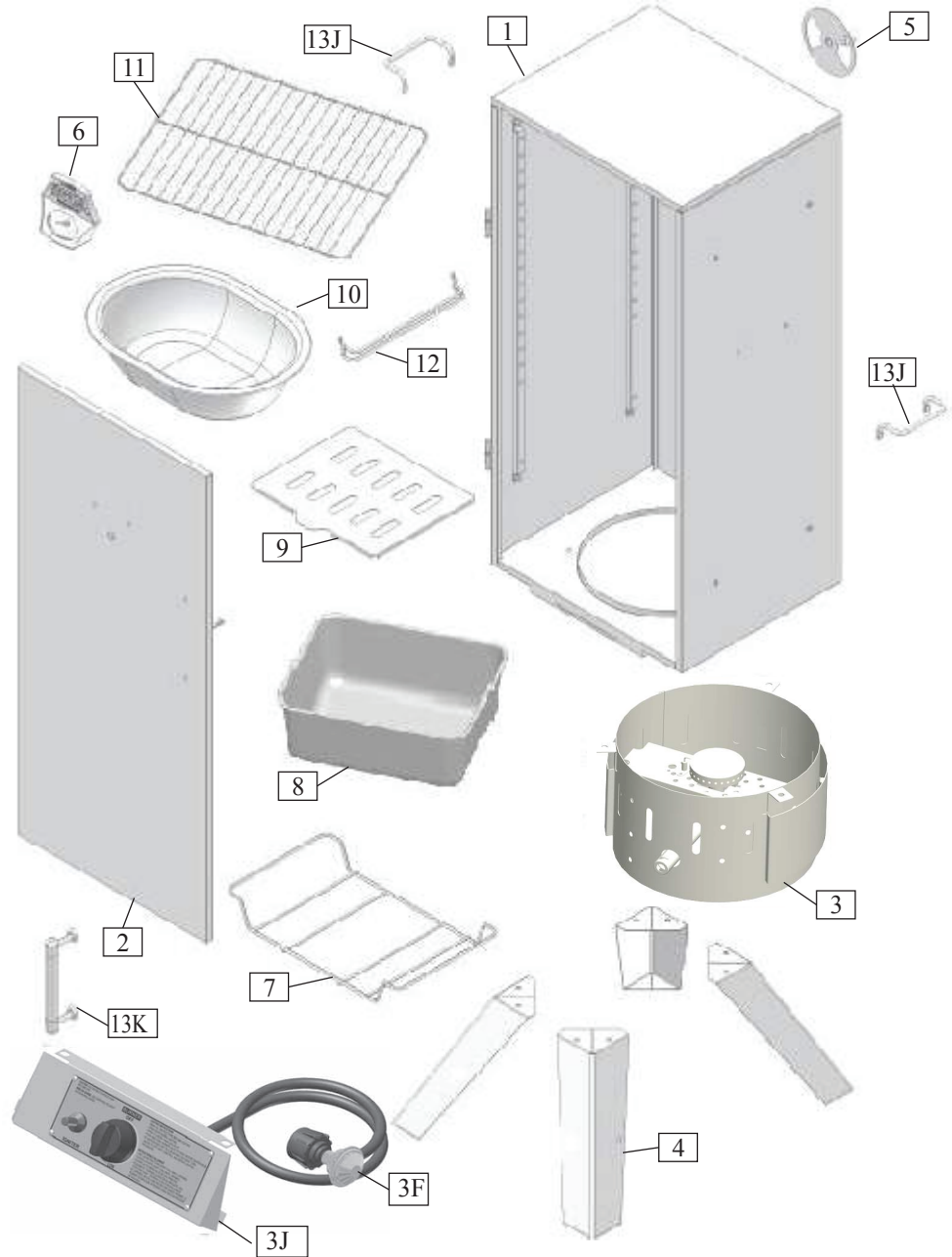

Primary Components			Part No.
Item	Qty	Description	34167G
1	1	Smoker Cabinet Assembly	3401000
2	1	Smoker Door	3402000
3	1	Burner Chamber Assembly	3403000
4	4	Smoker Leg	3A01000
5	1	Damper	3A02000
6	1	Nameplate/Heat Indicator	3A03000
6A	2	M5 Nut for Nameplate	3A03001
7	1	Wood Box Rack	3A04000
8	1	Wood Chip Box	3A05000
9	1	Wood Box Lid	3A06000
10	1	Water Bowl	3A07000
11	4	Cooking Grid	340400A
12	12	Short Grid Track	3A0800A
13	1	Master Hardware Pack	3405000
14	1	Owner's Manual	3A09000

Assembled Components			Part No.
Item	Qty	Description	34167G
1	1	Cabinet Assembly	3401000
1A	4	Grid Support Brackets	3401001
3	1	Burner Chamber Assembly	3403000
3A	1	Burner & Burner Tube	3403001
3B	1	Burner Support Bracket	3403002
3C	1	Igniter Electrode & Wire	3403003
3D	1	Push Button Igniter Unit	3403004
3E	1	LP Control Knob	3403005
3F	1	Hose-Valve-Regulator Ass'y	3403006
3G	1	Burner Chamber	3403007
3H	1	Chamber Air Baffle	3403008
3J	1	Control Panel	3403009
3K	1	Burner shield panel	3403010

Master Hardware Pack Contents			Part No.
Item	Qty	Description	34167G
13	1	Master Hardware Pack	3405000
13A	11	1/4-20x1/2" Bolt	Hardware A
13B	4	1/4-20x5/8" Bolt	Hardware B
13C	1	10-24x1/2" Bolt	Hardware C
13D	4	1/4-20 Flange Nut	Hardware B
13E	1	10-24 Nut	Hardware C
13F	1	10-24 Lock Washer	Hardware C
13G	1	Zip Tie	Hardware D
13H	1	S-Hook for Hose	Hardware D
13J	2	Carry Handle	3A10000
13K	1	Door Handle Kit	3A11000



Parts list for 34166GC

Before Assembly

Read all safeguards and assembly instructions before assembling and operating your smoker.

Before assembling your new smoker, unpack all the parts from the box. Carefully remove all packing material and lay out all the parts for easy access and identification. Do not discard the carton or packaging until your smoker is fully assembled and operating to your satisfaction.

In order to properly assemble your smoker, you will only need two tools:

- Phillips head screwdriver
- Pliers or 3/8" & 7/16" wrench

(tools not included)

Be sure to have a friend help. The smoker is heavy and must be moved around during assembly and before use.

To use your smoker immediately after assembly, have an L.P. gas cylinder filled by an authorized L.P. dealer or cylinder exchange center. Also, be sure to have your choice of flavoring wood readily available.

(L.P. Gas Cylinder and Flavoring Wood is not included)

For further assistance, including missing or damaged parts, call toll free: 866-475-5180 8:30am to 4:30pm, Central Time, Monday - Friday.

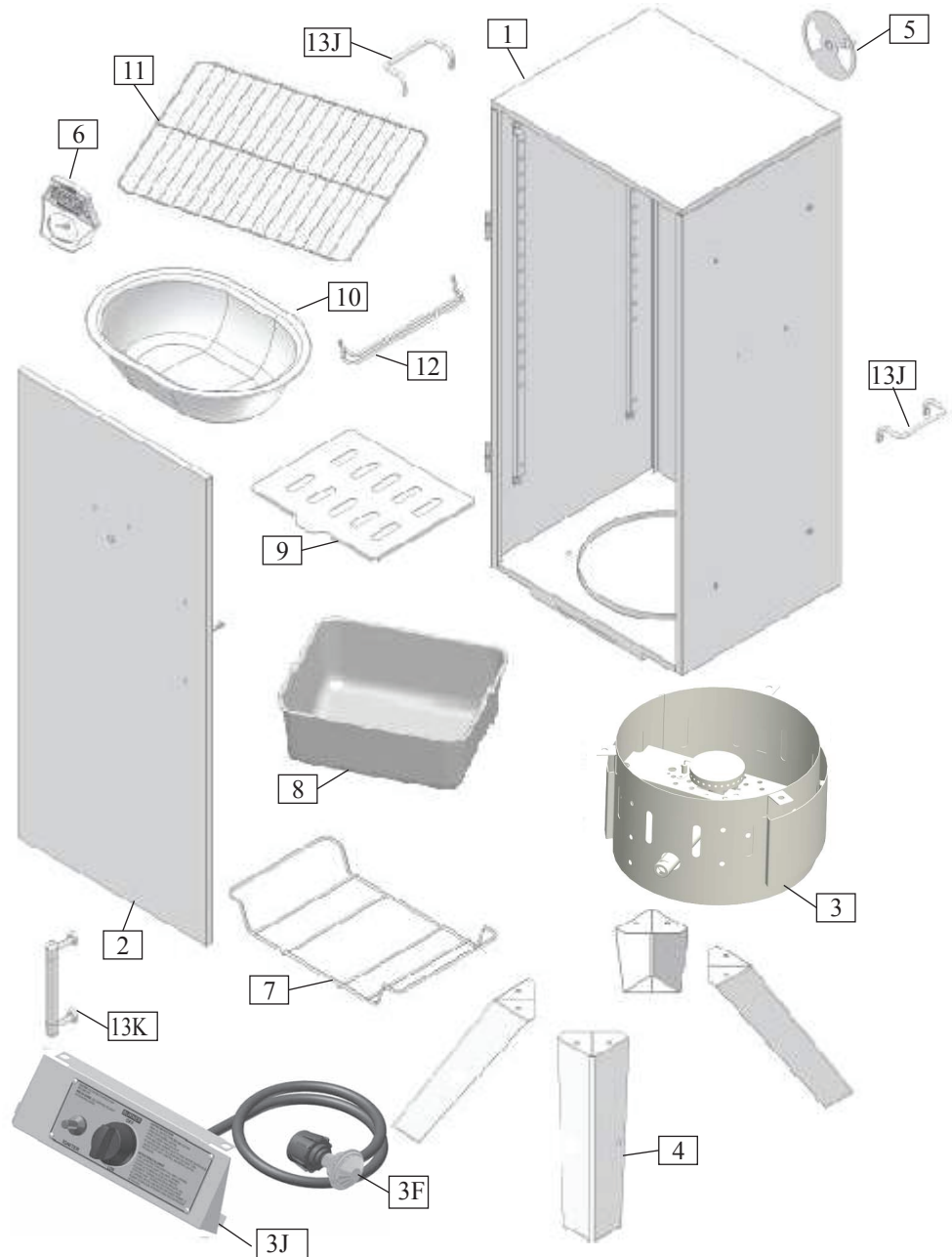

Primary Components			Part No.
Item	Qty	Description	34166GC
1	1	Smoker Cabinet Assembly	3401000
2	1	Smoker Door	3402000
3	1	Burner Chamber Assembly	3403000
4	4	Smoker Leg	3A01000
5	1	Damper	3A02000
6	1	Nameplate/Heat Indicator	3A03000
6A	2	M5 Nut for Nameplate	3A03001
7	1	Wood Box Rack	3A04000
8	1	Wood Chip Box	3A05000
9	1	Wood Box Lid	3A06000
10	1	Water Bowl	3A07000
11	3	Cooking Grid	340400A
12	10	Short Grid Track	3A0800A
13	1	Master Hardware Pack	3405000
14	1	Owner's Manual	3A09000

Assembled Components			Part No.
Item	Qty	Description	34166GC
1	1	Cabinet Assembly	3401000
1A	4	Grid Support Brackets	3401001
3	1	Burner Chamber Assembly	3403000
3A	1	Burner & Burner Tube	3403001
3B	1	Burner Support Bracket	3403002
3C	1	Igniter Electrode & Wire	3403003
3D	1	Push Button Igniter Unit	3403004
3E	1	LP Control Knob	3403005
3F	1	Hose-Valve-Regulator Ass'y	3403006
3G	1	Burner Chamber	3403007
3H	1	Chamber Air Baffle	3403008
3J	1	Control Panel	3403009
3K	1	Burner shield panel	3403010

Master Hardware Pack Contents			Part No.
Item	Qty	Description	34166GC
13	1	Master Hardware Pack	3405000
13A	11	1/4-20x1/2" Bolt	Hardware A
13B	4	1/4-20x5/8" Bolt	Hardware B
13C	1	10-24x1/2" Bolt	Hardware C
13D	4	1/4-20 Flange Nut	Hardware B
13E	1	10-24 Nut	Hardware C
13F	1	10-24 Lock Washer	Hardware C
13G	1	Zip Tie	Hardware D
13H	1	S-Hook for Hose	Hardware D
13J	2	Carry Handle	3A10000
13K	1	Door Handle Kit	3A11000



Parts list for 38207G

Before Assembly

Read all safeguards and assembly instructions before assembling and operating your smoker.

Before assembling your new smoker, unpack all the parts from the box. Carefully remove all packing material and lay out all the parts for easy access and identification. Do not discard the carton or packaging until your smoker is fully assembled and operating to your satisfaction.

In order to properly assemble your smoker, you will only need two tools:

- Phillips head screwdriver
- Pliers or 3/8" & 7/16" wrench

(tools not included)

Be sure to have a friend help. The smoker is heavy and must be moved around during assembly and before use.

To use your smoker immediately after assembly, have an L.P. gas cylinder filled by an authorized L.P. dealer or cylinder exchange center. Also, be sure to have your choice of flavoring wood readily available.

(L.P. Gas Cylinder and Flavoring Wood is not included)

For further assistance, including missing or damaged parts, call toll free: 866-475-5180 8:30am to 4:30pm, Central Time, Monday - Friday.

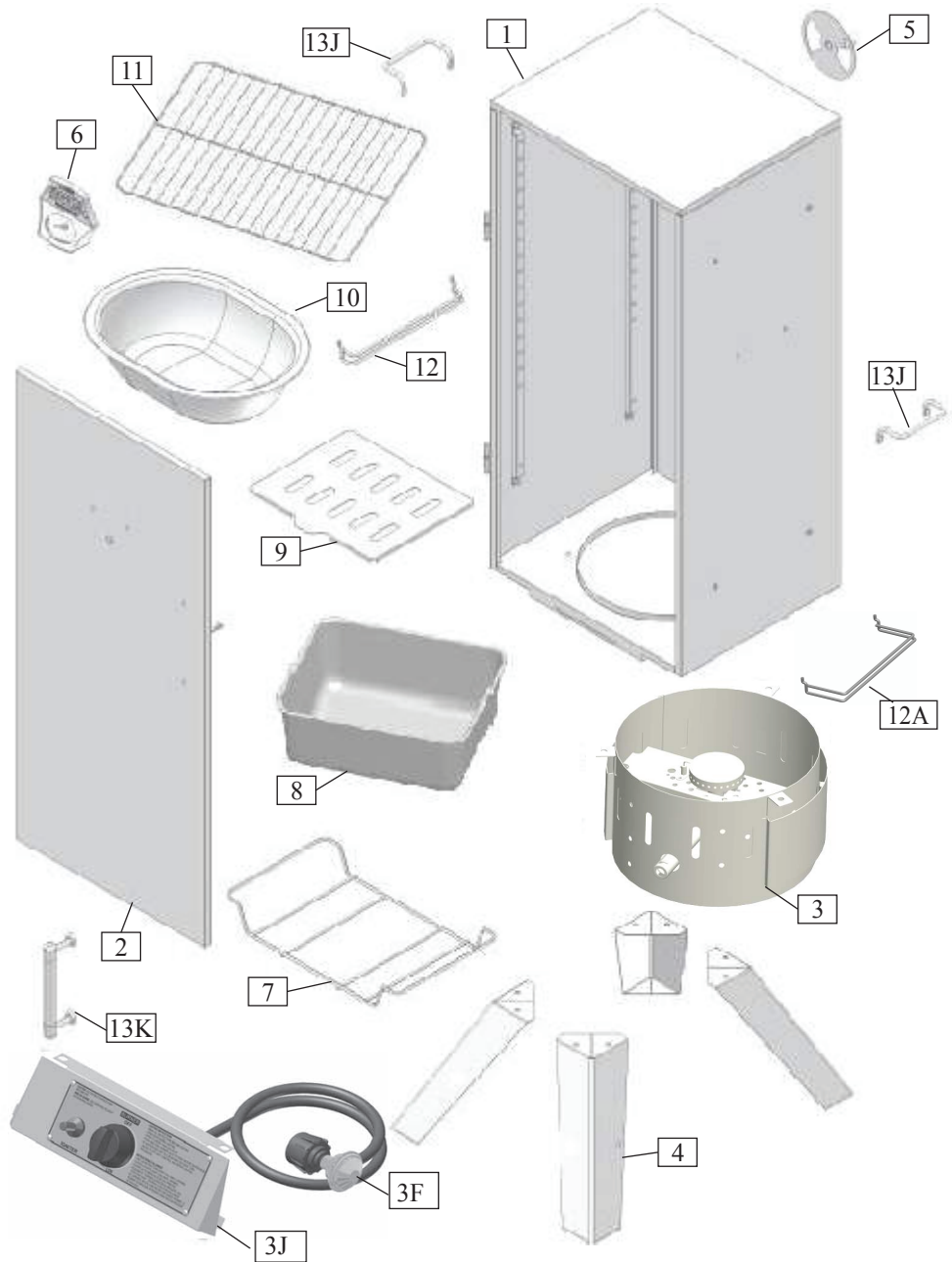

Primary Components			Part No.
Item	Qty	Description	38207G
1	1	Smoker Cabinet Assembly	3801000
2	1	Smoker Door	3802000
3	1	Burner Chamber Assembly	3803000
4	4	Smoker Leg	3A01000
5	1	Damper	3A02000
6	1	Nameplate/Heat Indicator	3A03000
6A	2	M5 Nut for Nameplate	3A03001
7	1	Wood Box Rack	3A04000
8	1	Wood Chip Box	3A05000
9	1	Wood Box Lid	3A06000
10	1	Water Bowl	3A07000
11	4	Cooking Grid	3804000
12	8	Short Grid Track	3A0800A
12A	4	Long Grid Track	3805000
13	1	Master Hardware Pack	3806000
14	1	Owner's Manual	3A09000

Assembled Components			Part No.
Item	Qty	Description	38207G
1	1	Cabinet Assembly	3801000
1A	4	Grid Support Brackets	3801001
3	1	Burner Chamber Assembly	3803000
3A	1	Burner & Burner Tube	3803001
3B	1	Burner Support Bracket	3803002
3C	1	Igniter Electrode & Wire	3803003
3D	1	Push Button Igniter Unit	3803004
3E	1	LP Control Knob	3803005
3F	1	Hose-Valve-Regulator Ass'y	3803006
3G	1	Burner Chamber	3803007
3H	1	Chamber Air Baffle	3803008
3J	1	Control Panel	3803009
3K	1	Burner shield panel	3803010

Master Hardware Pack Contents			Part No.
Item	Qty	Description	38207G
13	1	Master Hardware Pack	3806000
13A	11	1/4-20x1/2" Bolt	Hardware A
13B	4	1/4-20x5/8" Bolt	Hardware B
13C	1	10-24x1/2" Bolt	Hardware C
13D	4	1/4-20 Flange Nut	Hardware B
13E	1	10-24 Nut	Hardware C
13F	1	10-24 Lock Washer	Hardware C
13G	1	Zip Tie	Hardware D
13H	1	S-Hook for Hose	Hardware D
13J	2	Carry Handle	3A10000
13K	1	Door Handle Kit	3A11000



Parts list for 30167G

Before Assembly

Read all safeguards and assembly instructions before assembling and operating your smoker.

Before assembling your new smoker, unpack all the parts from the box. Carefully remove all packing material and lay out all the parts for easy access and identification. Do not discard the carton or packaging until your smoker is fully assembled and operating to your satisfaction.

In order to properly assemble your smoker, you will only need two tools:

- Phillips head screwdriver
- Pliers or 3/8" & 7/16" wrench

(tools not included)

Be sure to have a friend help. The smoker is heavy and must be moved around during assembly and before use.

To use your smoker immediately after assembly, have an L.P. gas cylinder filled by an authorized L.P. dealer or cylinder exchange center. Also, be sure to have your choice of flavoring wood readily available.

(L.P. Gas Cylinder and Flavoring Wood is not included)

For further assistance, including missing or damaged parts, call toll free: 866-475-5180 8:30am to 4:30pm, Central Time, Monday - Friday.

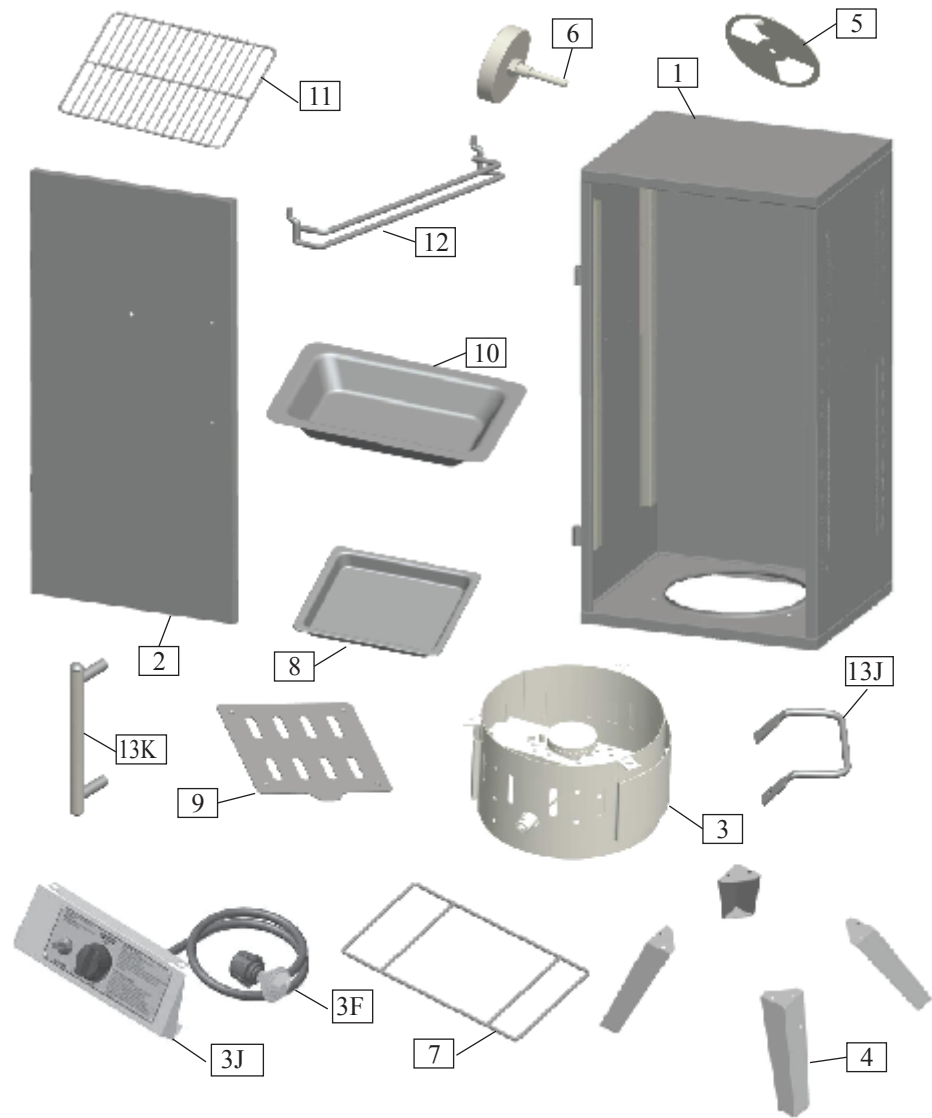

Primary Components			Part No.
Item	Qty	Description	30167G
1	1	Smoker Cabinet Assembly	3001000
2	1	Smoker Door	3002000
3	1	Burner Chamber Assembly	3003000
4	4	Smoker Leg	3A01000
5	1	Damper	3A02000
6	1	Heat Indicator	3B03000
6A	2	Nut for Heat Indicator	3B03001
7	1	Wood Box Rack	3004000
8	1	Wood Chip Box	3005000
9	1	Wood Box Lid	3006000
10	1	Water Bowl	3007000
11	4	Cooking Grid	340400A
12	12	Short Grid Track	3A0800A
13	1	Master Hardware Pack	3008000
14	1	Owner's Manual	3A09000

Assembled Components			Part No.
Item	Qty	Description	30167G
1	1	Cabinet Assembly	3001000
1A	4	Grid Support Brackets	3001001
3	1	Burner Chamber Assembly	3003000
3A	1	Burner & Burner Tube	3003001
3B	1	Burner Support Bracket	3003002
3C	1	Igniter Electrode & Wire	3003003
3D	1	Push Button Igniter Unit	3003004
3E	1	LP Control Knob	3003005
3F	1	Hose-Valve-Regulator Ass'y	3003006
3G	1	Burner Chamber	3003007
3H	1	Chamber Air Baffle	3003008
3J	1	Control Panel	3003009
3K	1	Burner shield panel	3003010

Master Hardware Pack Contents			Part No.
Item	Qty	Description	30167G
13	1	Master Hardware Pack	3008000
13A	11	1/4-20x1/2" Bolt	Hardware A
13B	4	1/4-20x5/8" Bolt	Hardware B
13C	1	10-24x1/2" Bolt	Hardware C
13D	4	1/4-20 Flange Nut	Hardware B
13E	1	10-24 Nut	Hardware C
13F	1	10-24 Lock Washer	Hardware C
13G	1	Zip Tie	Hardware D
13H	1	S-Hook for Hose	Hardware D
13J	2	Carry Handle	3A10000
13K	1	Door Handle Kit	3B11000

Assembly

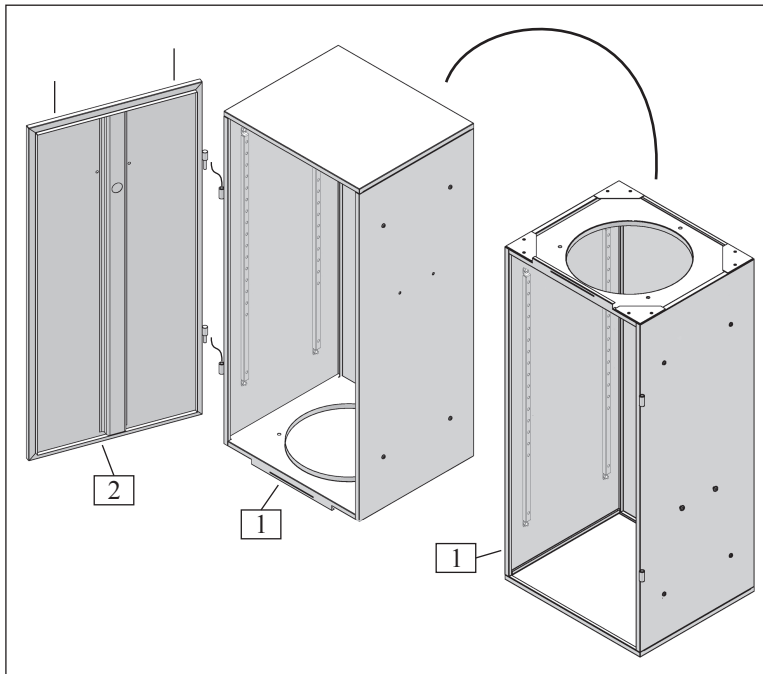

Step 1:

Locate: Cabinet Assembly [1], Door Panel [2]

Note: The door panel [2] is attached to the cabinet assembly [1].

Tools Needed: None

Procedure:

Remove the door panel [2] from the cabinet assembly [1] by lifting straight up on the door. Set the door panel aside.

Turn the cabinet assembly [1] upside down.

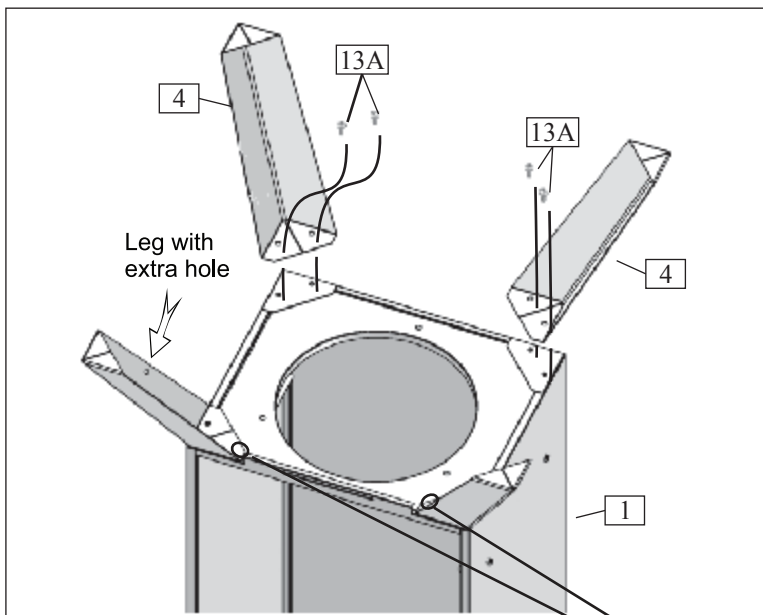

Step 2:

Locate: Four Smoker Legs [4], Eight 1/4-20x1/2" Bolts [13A] from the hardware A.

Tools Needed: Phillips head screwdriver

Procedure:

Place each leg [4] at the corner of the smoker cabinet assembly [1] as shown. Fasten each leg [4] with two 1/4-20x1/2" bolts [13A]. Nuts are pre-welded to the cabinet.

Note: One leg contains an extra hole on its side and must be mounted at the front in the position shown. This hole will be used later to secure the gas hose to the leg with a zip-tie.

Do not yet insert the two bolts in the location indicated. These two bolts will be used in next assembly steps.

Securely tighten six bolts.

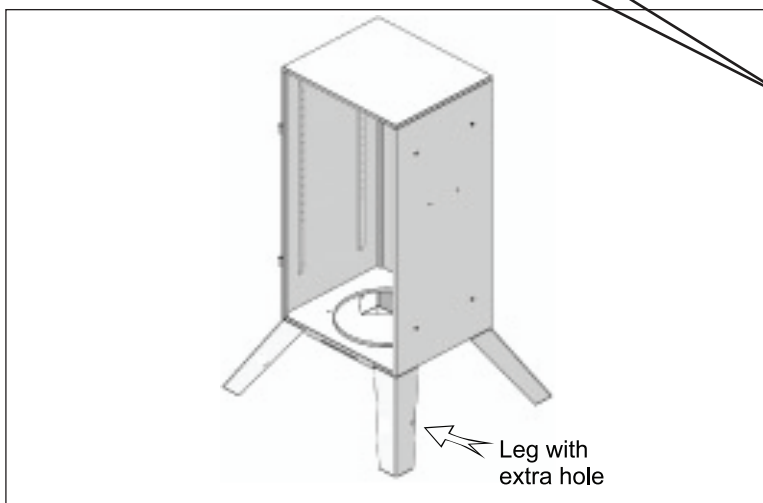



Assembly

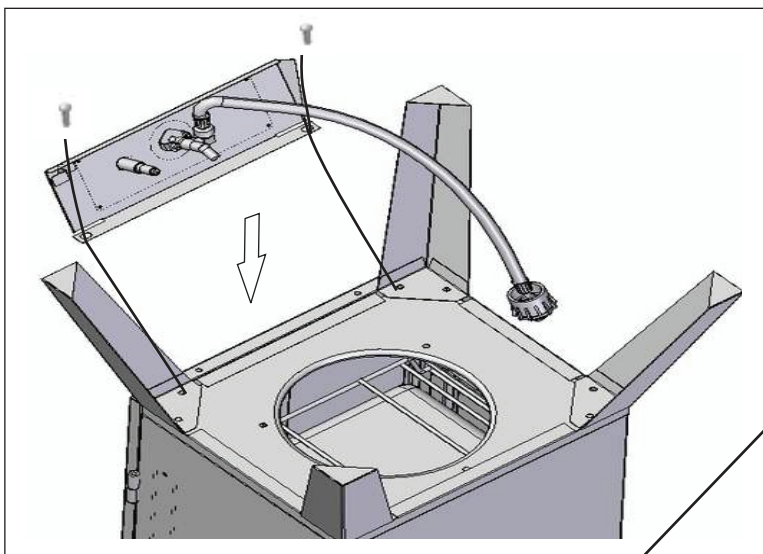

Step 3:

Locate: Control panel assembly [3], Two 1/4-20x1/2" Bolts [13A] (2 Remaining from previous step).

Tools Needed: Phillips head screwdriver

1. Place the control panel assembly between the front legs as shown. There are slots on the control panel that fit around the legs and line up with the bolt holes

2. Be sure all the tabs on the back side of the control panel are captured around the legs as shown below.

3. Insert the two remaining bolts and tighten them securely

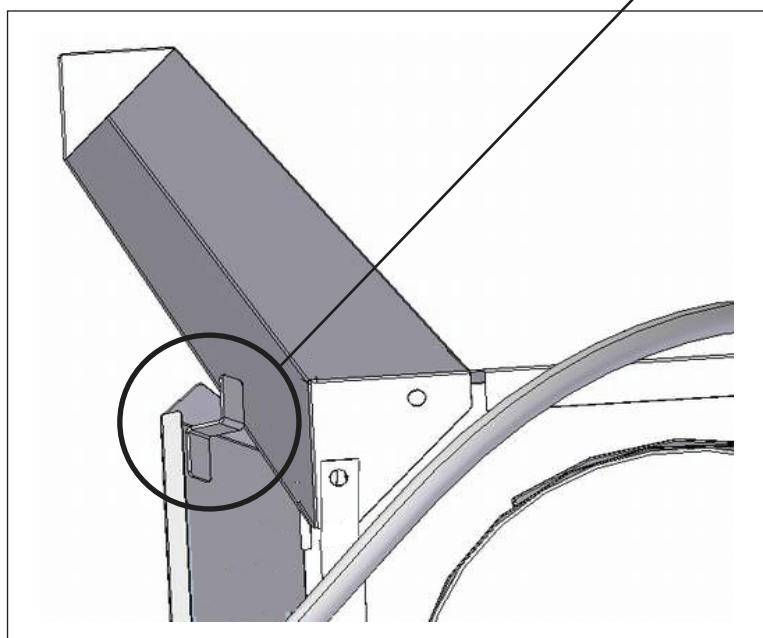

Step 4:

Locate: Burner Chamber Assembly [3], Three 1/4-20X1/2" Bolts [13A] From the hardware A.

Tools Needed: Phillips head screwdriver

Note: Inspect the burner chamber prior to assembly to make certain the burner tube is correctly over the end of the valve as shown:

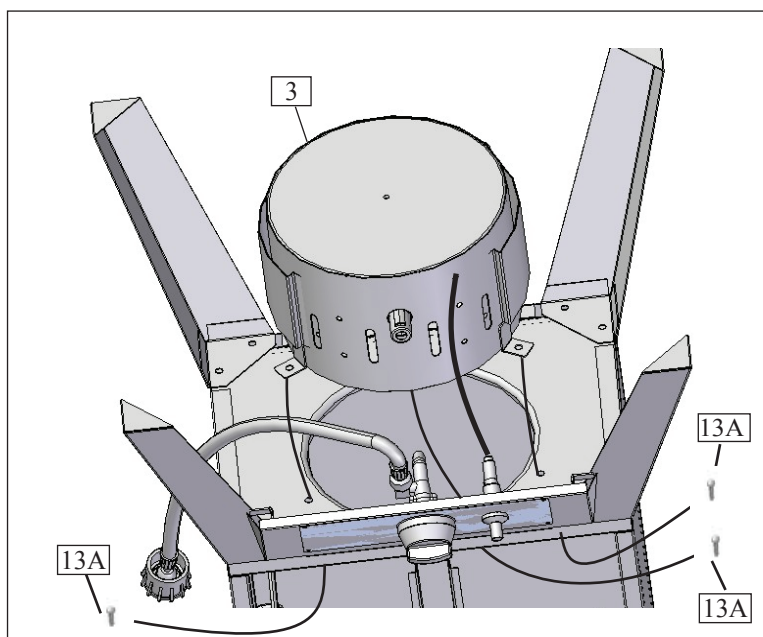
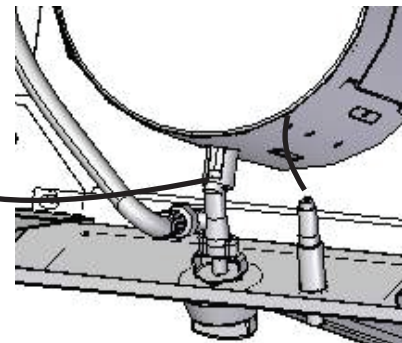

Procedure:

Align the burner chamber assembly [3] underneath the smoker as shown.

Place the body of the burner chamber assembly so that it sits flush with the bottom of the cabinet. The mounting holes and mounting tabs should line up.

For each mounting hole, insert a 1/4-20X1/2" bolt [13A]. secure the burner assembly with the three bolts from the inside of the cabinet.

Securely tighten all three bolts.

Attach the loose igniter wire to the igniter on the control panel as shown.

Assembly

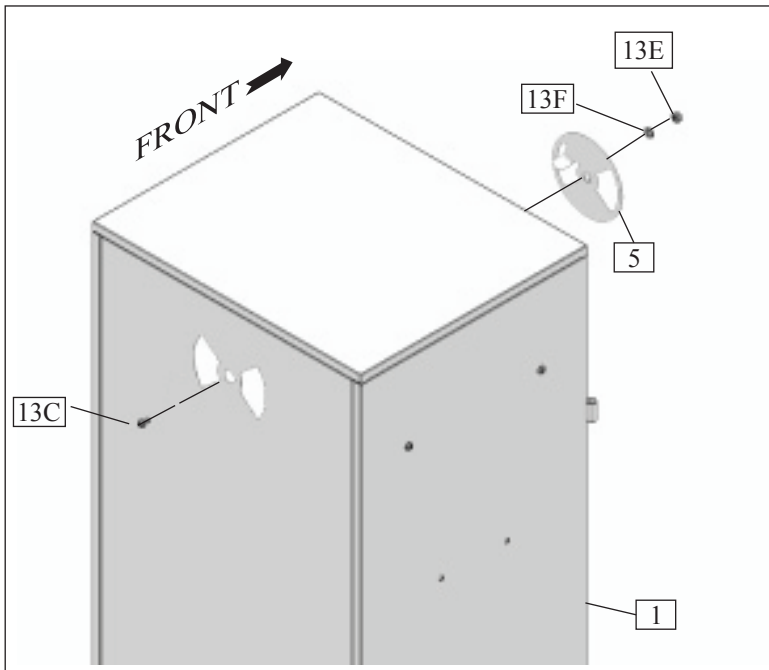

Step 5:

Locate: Damper [5], one 10-24x1/2" Bolt [13C], 10-24 nut[13E].10-24 Lock washer[13F]

Tools Needed: Phillips head screwdriver and 3/8" wrench or pliers

Procedure:

From the outside of the cabinet, insert a 10-24x1/2" bolt [13C] through the mounting hole for the damper.

From the inside of the smoker cabinet, place the damper [5] over the vent hole in the back of the cabinet as shown. The tab on the damper must mount through the vent hole.

From the inside of the cabinet, place the 10-24 lock washer [13F] on the bolt and tightly thread the 10-24 nut [13E] onto the bolt.

The damper must be able to rotate with just a little resistance.

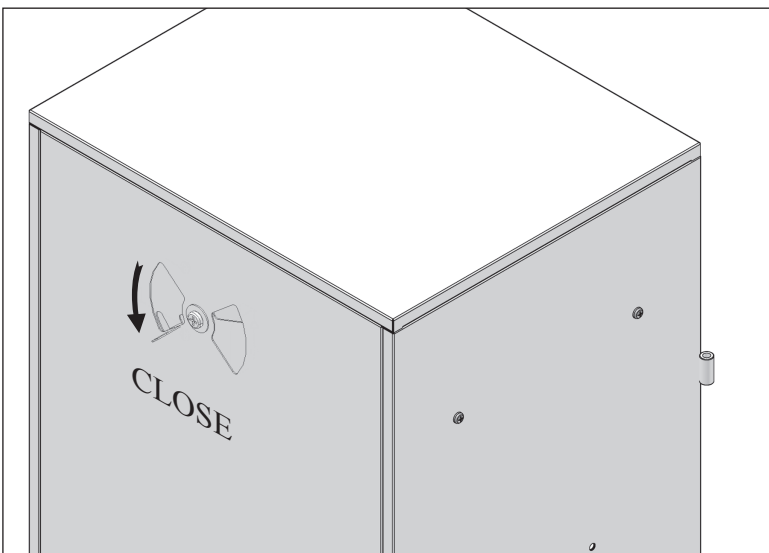

The damper allows adjustment of exhaust air while cooking. Less exhaust air will allow for the smoker to burn hotter and keep the flavoring smoke inside the smoker.

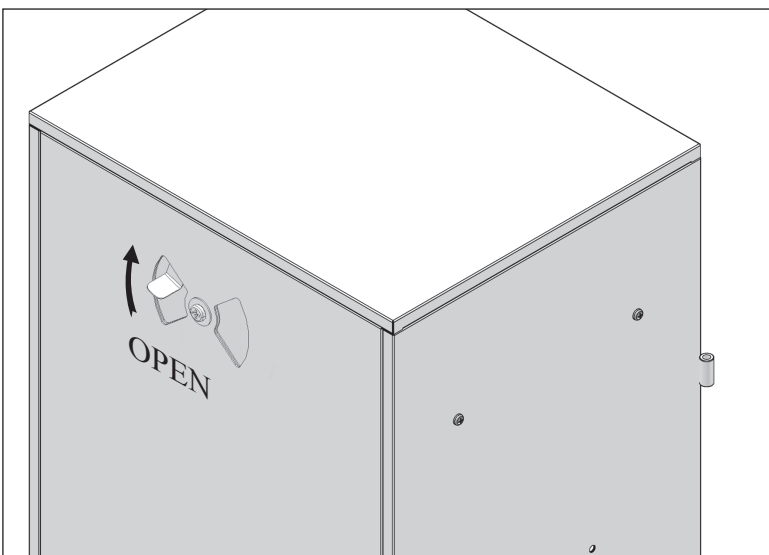



Assembly

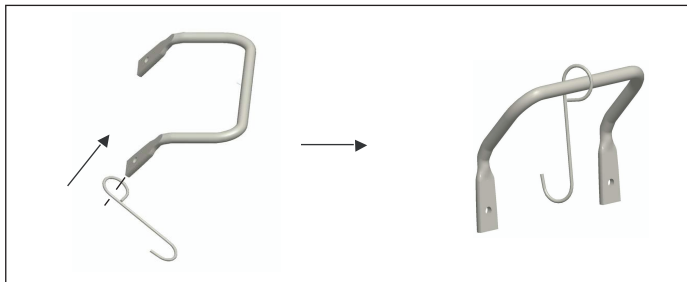

Step 6:

Locate: Two Carry Handles [13J], one S-Hook(13H), Four 1/4-20x5/8" Bolts [13B], and Four 1/4-20 Flange Nuts [13D]

Tools Needed: Phillips head screwdriver and a 7/16" wrench or pliers

Procedure :

Put the ring end of the S-hook on one carry handle [13J] as shown. Use two 1/4-20x5/8" bolts [13B] and two 1/4-20 flange nuts [13D] to attach the handle on right side of the smoker cabinet [1].

Mount other carry handle [13J] to the left side of the cabinet [1] as shown. Use two 1/4-20x5/8" bolts [13B] and two 1/4-20 flange nuts [13D] to attach the handle.

Securely tighten the bolts.

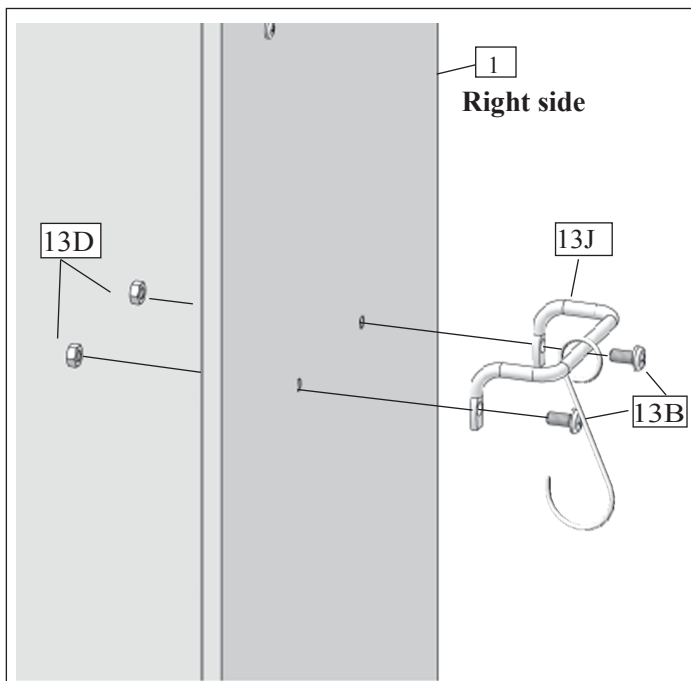

Step 7:

Locate: Door Panel [2]

Tools Needed: None

Procedure:

Re-mount the smoker door [2] to the cabinet.

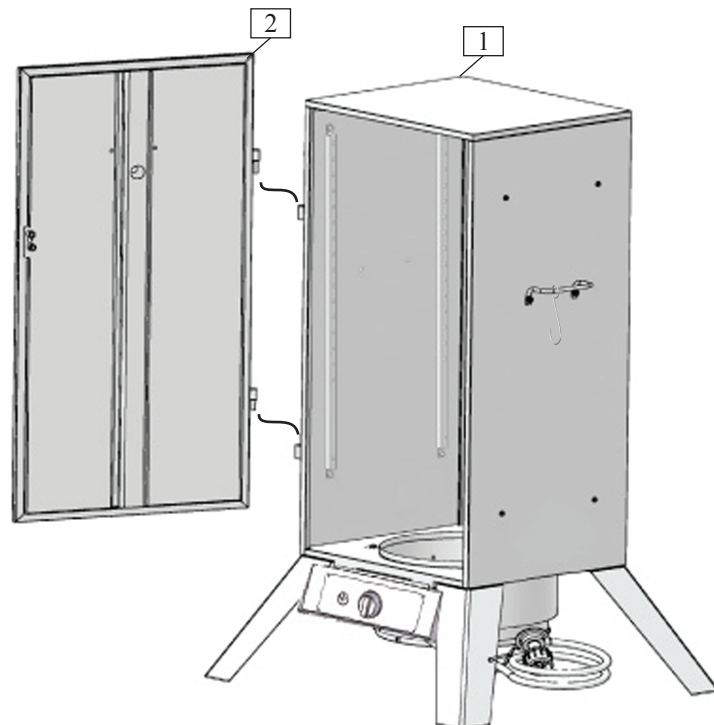
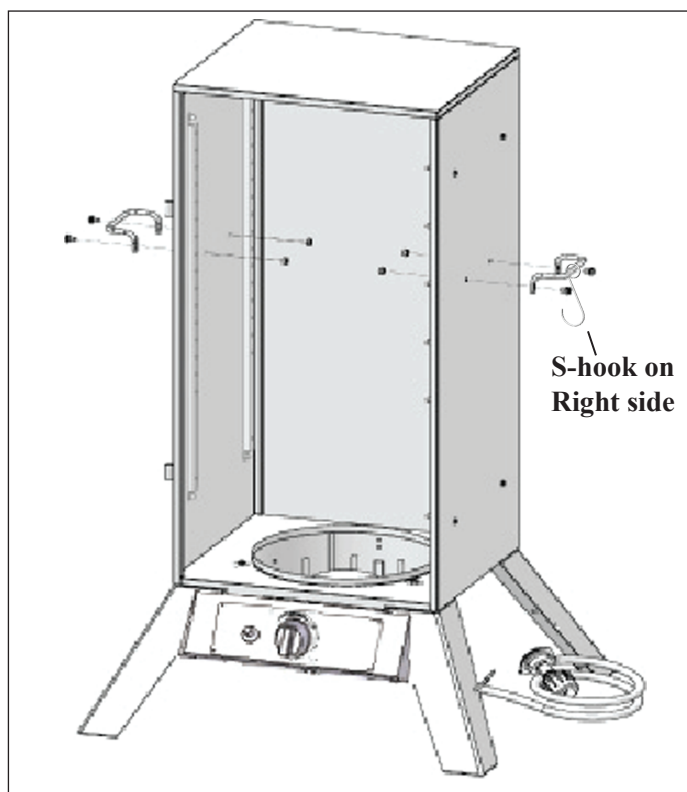

Assembly

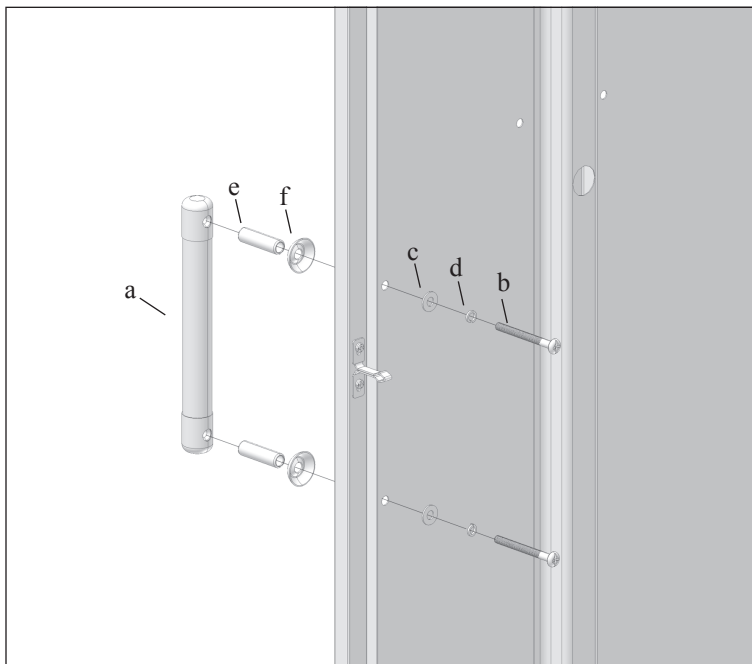

Step 8:(34167G/34166GC/38207G Model)

Locate: 34167G/34166GC/38207G Door handle kit [13K]

Note: The door handle kit [13K] consists of one door handle (a), two 10-24x2” bolts (b), two 10-24 flat washers (c), two 10-24 lock washers (d), two 1.5” long spacers (e) and two caps (f).

Procedure:

With a flat washer (c) and lock washer (d) on a bolt (b), insert each bolt through the door from the inside. From the outside place a cap (f) and spacer (e) over each bolt. Then thread the bolts into the handle (a).

Securely tighten two bolts.

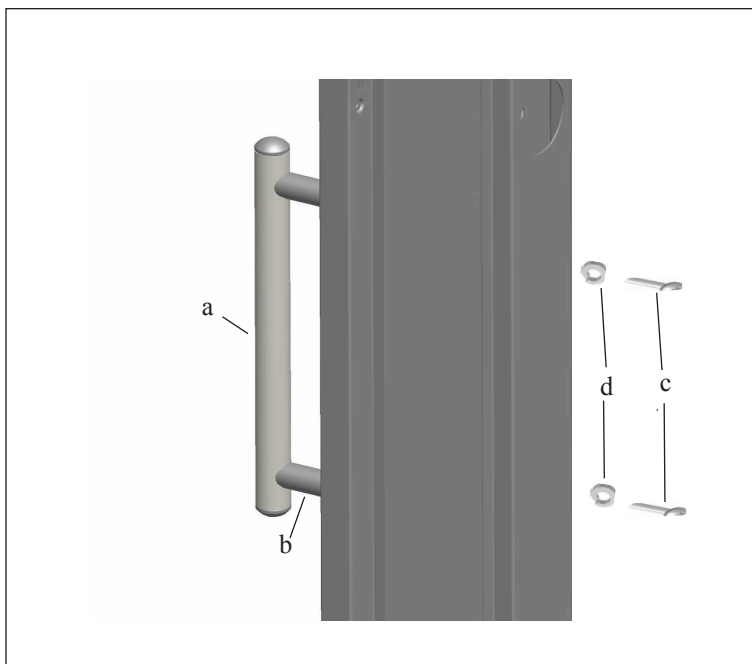

Step 8:(30167G Model)

Locate: 30167G Door handle kit [13K]

Note: The door handle kit [13K] consists of one door handle (a), two 2” spacers (b) two 10-24x2 3/8” bolts (c), two 10-24 lock washers (d).

Procedure:

With a lock washer (d) on a bolt (c),insert each bolt through the door from the inside. From the outside place a spacer (b) over each bolt.

Then thread the bolts into the handle (a).

Securely tighten all two bolts.

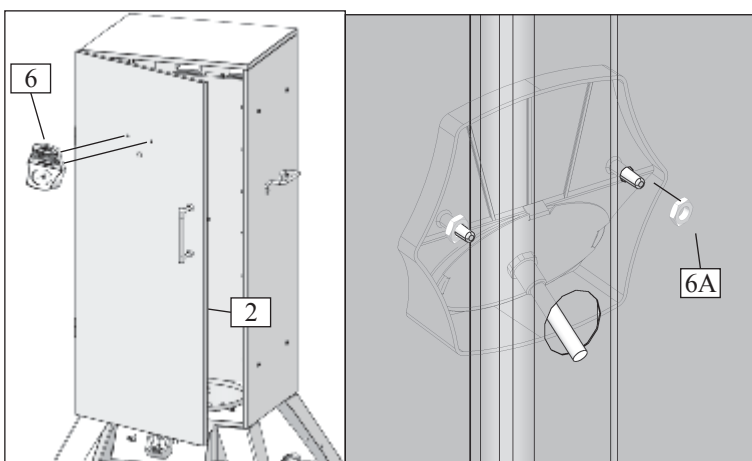

Step 9:(34167G/34166GC/38207G Model)

*Locate:*34167G/34166GC/38207G Heat Indicator / Nameplate [6]

Note: The heat indicator/nameplate [6] is supplied with two M5 nuts [6A].

Tools Needed: Pliers

Procedure:

Mount the heat indicator/nameplate [6] to the front of the door panel [2] using the three corresponding holes.

From the inside of the door panel, secure the nameplate with the two supplied nuts [6A] and tighten firmly.

continued...

Assembly

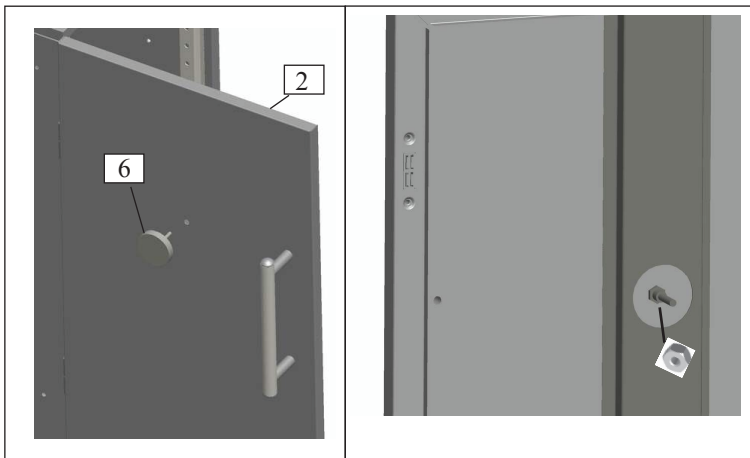

Step 9:(30167G model)

Locate: 30167G Heat Indicator [6]

Note: The heat indicator is supplied with a nut.

Tools Needed: None

Procedure:

Insert the heat indicator probe through the mounting holes in the front of the door panel[2].

Keep normal temperature indicator positions, securely tighten the nuts From the inside of the door panel.

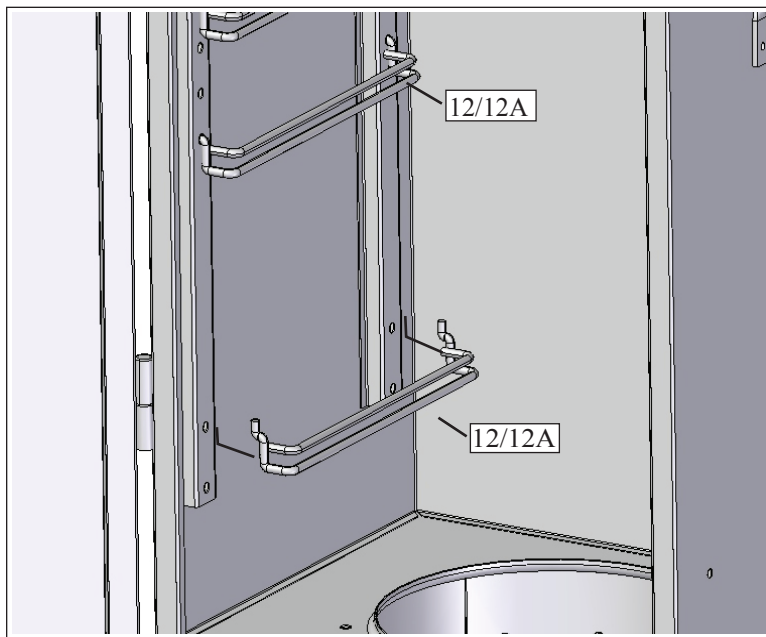

Step 10:

Locate : **34167G/30167G:** Twelve short grid racks [12], One Wood Box Rack [7].Four Cooking Grids [11].

34166GC: Ten short grid racks [12], One Wood Box Rack [7]. Three Cooking Grids [11].

38207G: Eight short grid racks for cooking grids[12]. Four long grid racks for the wood box rack and water pan [12A], One wood box rack[7].Four Cooking Grids [11].

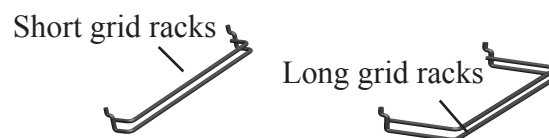

Tools needed: None

Procedure:

Install one grid track [12] in each of the bottom holes located in the grid support for both the left and right sides of the cabinet.

Slide the wood box rack [7] onto the bottom grid tracks [12]/[12A].

Install the remaining grid tracks [12] as desired among the grid support holes (5 on each side). Be sure to place a set of grid tracks at the bottom-most set of holes for the water bowl.

Ensure the grid tracks are at the same level on both sides of the cabinet.

Slide a cooking grid [11] into each of the top grid supports [12].

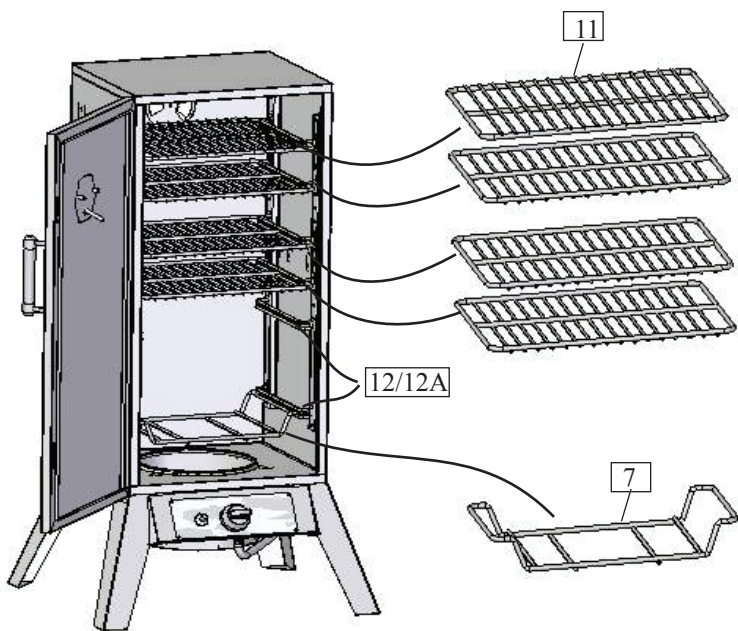



Assembly

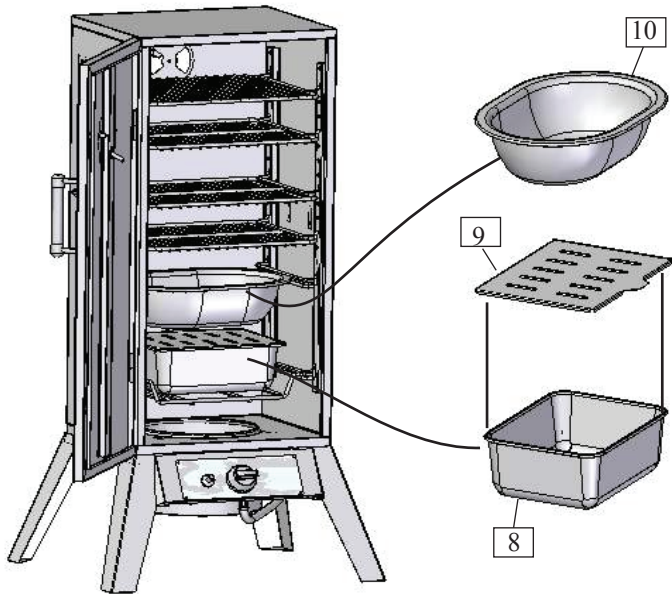

Step 11:

Locate: Wood Chip Box [8], Wood Chip Box Lid [9], Water Bowl [10]

Tools Needed: None

Procedure:

Place the wood chip box lid [9] onto the wood chip box [8].

Set the wood chip box [8] onto the wood chip box rack already inside the smoker cabinet.

Place the water bowl [10] onto the lowest rack position inside the smoker cabinet, just above the wood chip box.



34167G/34166GC Model

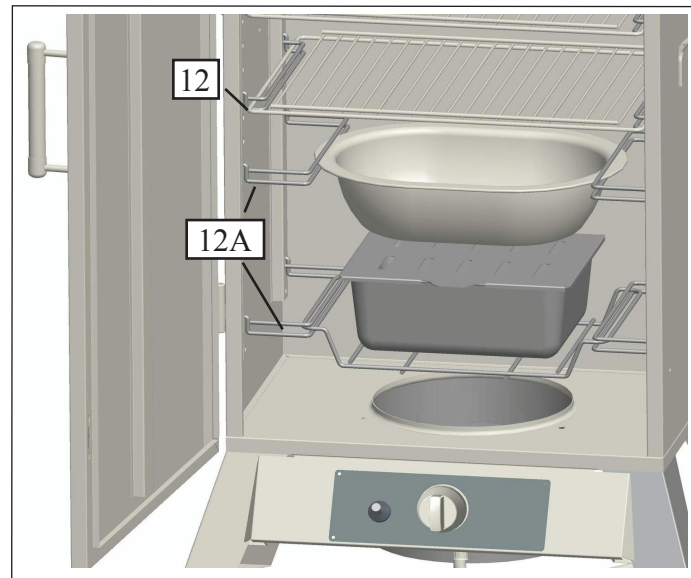

38207G Model

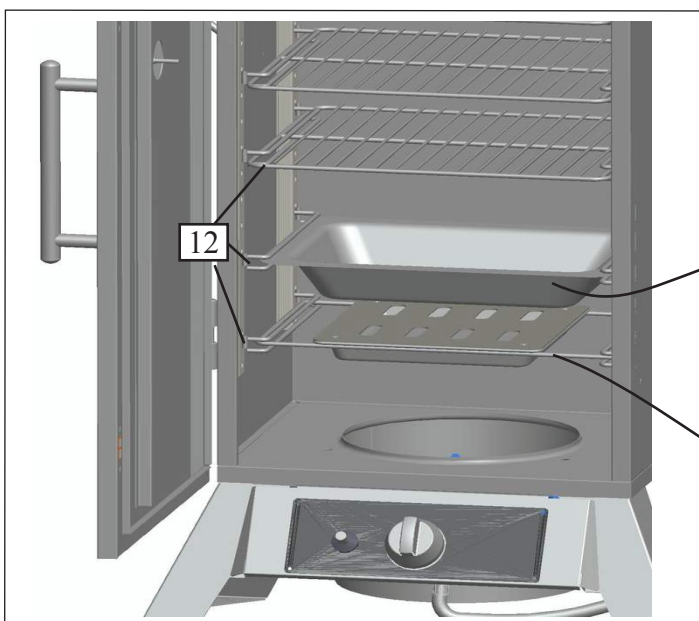

30167G Model

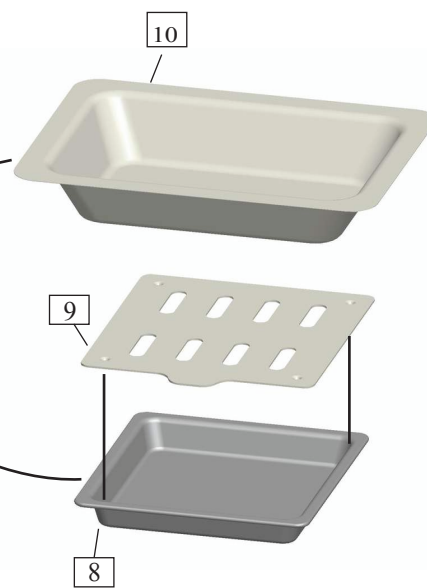

Assembly

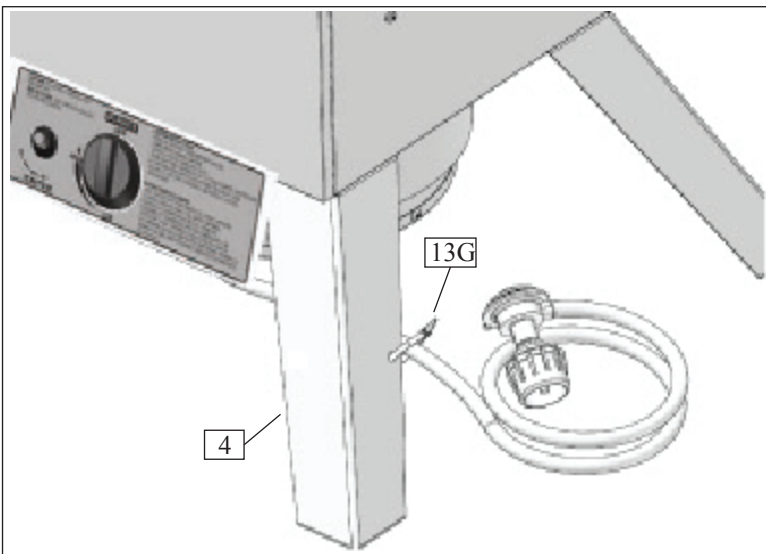

Step 12:

Locate : Zip Tie [13G]

Tools Needed : None

Procedure :

Loop the zip tie [13G] through the outside hole of the front smoker leg [4] as shown.

Capture the gas hose with the zip tie to secure it. Do not pull the zip tie too tight - it may restrict gas flow through the hose.

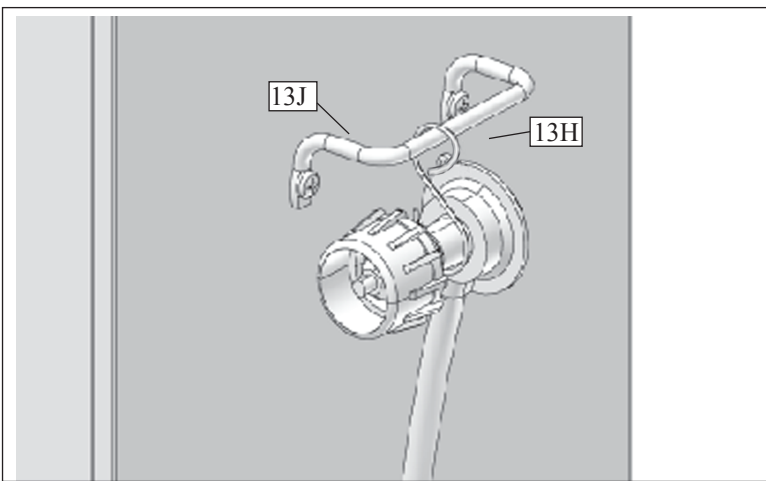

Step 13:

Locate: S-Hook [13H], Regulator[3F]

Tools Needed : None

Procedure :

Wrap the end of the S-Hook [13H] around the neck of the regulator at the end of the hose. Squeeze the end of the hook around the regulator so that it can not come off.

Hang the regulator with the S-Hook [13H] as shown. This is to prevent the regulator from collecting debris from the ground during storage and while moving the smoker.

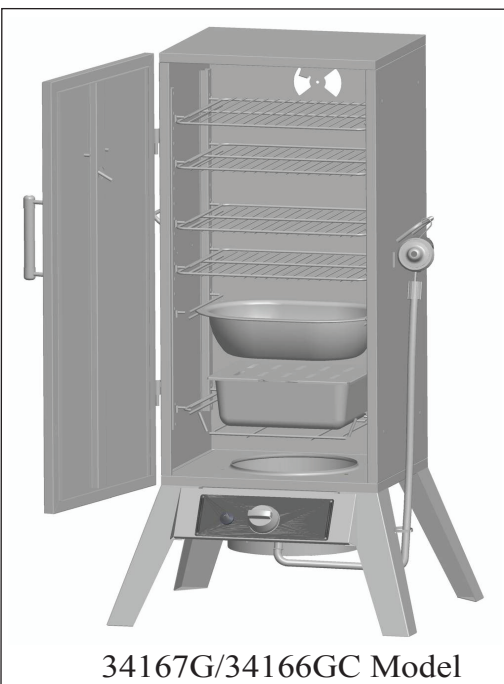

34167G/34166GC Model



38207G Model



30167G Model

Assembly of your smoker is now complete. The following section refers to LP gas cylinder installation and use.
FOR YOUR SAFETY, FOLLOW ALL SAFEGUARDS AND INSTRUCTIONS.



Connecting the LP Gas Cylinder

⚠ DANGER

ALL INSTRUCTIONS AND SAFEGUARDS MUST BE FOLLOWED TO PREVENT FIRE, PROPERTY DAMAGE, OR PERSONAL INJURY.

IMPORTANT: Any fuel supply cylinder used must be constructed and marked in accordance with specifications for propane cylinders of the U.S. Department of Transportation (DOT) CFR 49, or CAN/CSA B339. The appliance is to be used only with the 20 pound, vertical standing vapor withdrawal type tank.

This smoker is designed to operate on LP (Liquefied Propane) gas only. This unit is not to be utilized with a non-self-contained LP-gas supply system.

The 20 lb LP cylinder used with this smoker must conform to the following requirements.

Diameter- 12" (30.5cm)

Height 18" (45.7cm)

With a maximum capacity of 20 pounds

The gas cylinder used must include a collar to protect the cylinder valve. The cylinder supply system must be arranged for vapor withdrawal.

⚠ The instructions stated on gas cylinder tanks have to be followed when filling or transporting tanks. Failure to do so could result in problems relating to overfilling, excessive venting release of gas and to regulator freezing.

Do not allow dirt or foreign material to get into or onto tank connection when it is not attached to the fuel supply system. Place the dust cap on cylinder valve outlet whenever the cylinder is not in use. Only install the type of dust cap on the cylinder valve outlet that is provided with the cylinder valve. Other types of caps or plugs may result in leakage of propane.

⚠ DANGER

⚠ (A) Do not store tanks under or near the smoker.

⚠ (B) Never fill tanks more than 80% full.

⚠ If instructions A and B above are not followed exactly, a fire causing death or serious injury may occur.



Cylinders must be filled before initial use. All handling, transport, filling and storage of LP gas cylinders must be in accordance with *NFPA 58 Storage and Handling of Liquid Petroleum Gases*, or *CSAB 149.1 Natural Gas and Propane Installation Code*. Cylinders must be suitably tied down during transport. Do not place any other items on top of cylinders at any time. Cylinders are not to be exposed to excessive temperatures or high heat.

If there is a question on the identity of your unit and of the type of fuel to be used, please look on the data plate. Units are factory equipped for use on only one type of fuel. These units cannot be, and should not be used on other type of fuels. Doing so can cause severe damage to the unit and the installation area and the added risk of serious injury. Any attempt to operate these smokers on fuels for which they are not design certified voids the manufacturer's warranty.

Gas Tank outlet must have Type 1 gas connection termination in order to mate with gas hose provided with smoker.

The pressure regulator and hose assembly supplied by the manufacturer with the appliance must be used. Replacement pressure regulators and hose assemblies must be those specified by the appliance manufacturer.

The regulator/hose assembly should be handled carefully to prevent contamination by foreign objects and dirt. The assembly should be inspected before use and any dirt or contamination should be wiped off. In order to insure proper operation, any replacement of the fuel tank regulator assembly has to be done with parts authorized by the smoker manufacturer.

Connecting the LP Gas Cylinder



⚠ DANGER

ALL INSTRUCTIONS AND SAFEGUARDS MUST BE FOLLOWED TO PREVENT FIRE, PROPERTY DAMAGE, OR PERSONAL INJURY.

⚠ Valve/pressure regulators are factory set to the correct operating pressures. No attempts should be made to adjust these settings!

Connecting the LP Gas Cylinder:

1. The valve on the LP tank must be closed. See that the knob is turned clockwise to a full stop.
2. Check that the control knob on the smoker is turned off.
3. Remove the protective cap from the LP tank valve and coupling nut, if present.
4. Hold the regulator in one hand and insert the nipple into the valve outlet. Be sure the nipple is centered in the valve outlet. The coupling nut connects to the large outside threads on the valve outlet. Use care - do not cross thread the connection.
5. Hand tighten the coupling nut clockwise until it comes to a full stop. Firmly tighten by hand only. Do not use tools.

CAUTION: In the connection process, the regulator side of the connection will seal on the back check in the valve, resulting in a slight resistance. The connection requires about one-half to three-quarters additional turn to complete the connection.

When setting up the smoker and tank, it is recommended to have the tank and smoker on a line perpendicular to the wind direction.

The gas hose/regulator assembly should be totally extended to the maximum distance so that the hose is straight and the tank is as far from the smoker as it can be.

LP tanks are intended for operation in the upright position only.

Care should be taken to protect the fuel supply hose from damage from either foot or vehicle traffic.

If the appliance is not in use, the gas must be turned off at the supply cylinder and the cylinder should be disconnected from the appliance.

Storage of the appliance indoors is only permissible if the cylinder is disconnected and removed from the appliance.

Cylinder must be stored outdoors out of the reach of children and must not be stored in a building, garage or any other enclosed area.

Leak Testing (Checking for gas leaks)

After all connections are completed, check all connections and fittings for leaks with a soap solution.

- Mix dish soap with water; about 3:1 mix ratio.
- With all valves closed, apply the soap solution to all gas flow connections and fittings.
- Open tank valve about 1-1/2 turn.

Presence of bubbles at areas of wet solution indicates a gas leak.

If leaks are detected or you smell or hear gas, shut off the valve and repair the leak or replace the defective part. Do not use the smoker until all leaks are corrected.

⚠ DANGER

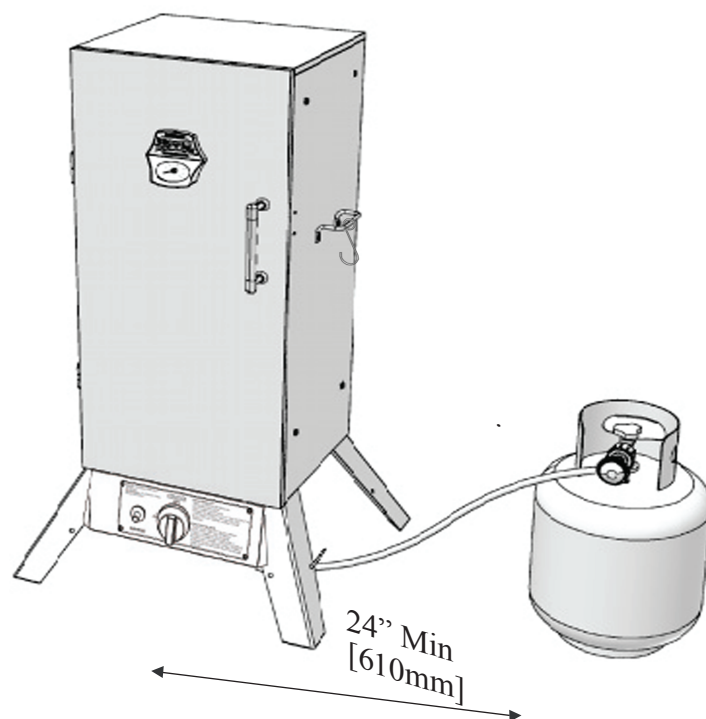



Operation: Before Use

Pre-Use Procedures

Your smoker has been packaged with a retail store level point-of-purchase label that hangs on the front of the door panel. This label must be removed before use. To remove the label, simply cut or tear along the indicated line and pull the top portion of the label from behind the name plate.

Before you cook food in your smoker, it is important to “season” your smoker. Seasoning seals the paint and interior of your smoker to enhance flavoring, durability, and overall performance. This is also referred to as the “break-in” process.

If your smoker requires any touch-up paint on the inside of the cabinet, the only time you should apply paint to the inside is before the seasoning process. Paint should not be applied to the interior of your smoker after your smoker has been used. Paint toxins may contaminate your food. However, if paint becomes necessary after use, see the section in this manual concerning After Use Care and Maintenance.

To season your smoker, simply use it as you normally would; only do not cook any food. You will need to follow all of the operating procedures in the next few sections of this manual.

Using your desired flavoring woods and marinades, burn your smoker at lowest temperature for 45-60 minutes. Let the smoker cool, and clean out the used water and wood.

Once seasoning is complete, your smoker's interior will have a durable, seasoned coating.

Adding Water

To add water before cooking, simply remove the water bowl and fill it with water up to 1” (2.5 cm) below the rim. Then replace the bowl to the rack.

To add water while the smoker is hot, DO NOT pull the water bowl out beyond the rack. Use a clean cup or watering can to add water to the water bowl while in use.

For easier cleaning, line the water bowl with aluminum foil before each use.

Adding Wood

To add wood before cooking, simply fill the wood chip box with your choice of flavoring hardwood chips. The amount and type of wood you use is entirely up to you. One full box is typically enough for several hours of smoking. Once the box is filled with wood, place the lid on top of the box and set the box in the smoker.

To add wood while cooking, use tongs or long handled pliers to remove the box lid and to place the pieces into the wood chip box without removing the box. It is not recommended to remove the wood chip box while the smoker is in operation.

CAUTION! : The wood chip box and lid get very hot. Avoid handling them while in use. Always wear protective oven mitts when handling hot components.

Using Flavoring Wood

Small wood chips work best inside the wood chip box.

Use dry hardwoods such as hickory, pecan, apple, cherry, or mesquite.

Most fruit or nut tree woods produce excellent smoke flavoring.

Do not use resinous woods such as pine or plywood. These usually produce unpleasant flavoring.

Experiment with different types and quantities of wood chunks, chips, or sticks. Different woods can also be mixed.

To produce more smoke and to prevent fast burning, pre-soak the wood chips in a separate bowl of water for at least 20 minutes, or wrap the chips in perforated aluminum foil.

Most smoke flavoring occurs within the first hour of cooking. Adding wood chips after the first hour is typically not necessary unless extra smoke flavoring is desired.

Operation: Lighting



LP Gas Lighting Procedure

1. Check all connections for leaks using the leak test as explained on page 18.
2. Open the smoker door.
3. Check for any blockage to the venturi tube or burner. Remove any foreign objects or matter.
4. Be sure the burner control knob is in the "OFF" position.
5. Open the LP cylinder valve **1-1/2 turn** by turning counter-clockwise.
6. To light unit with the push-button igniter, push in and turn the burner control knob counter-clockwise to the HIGH/LIGHT setting.

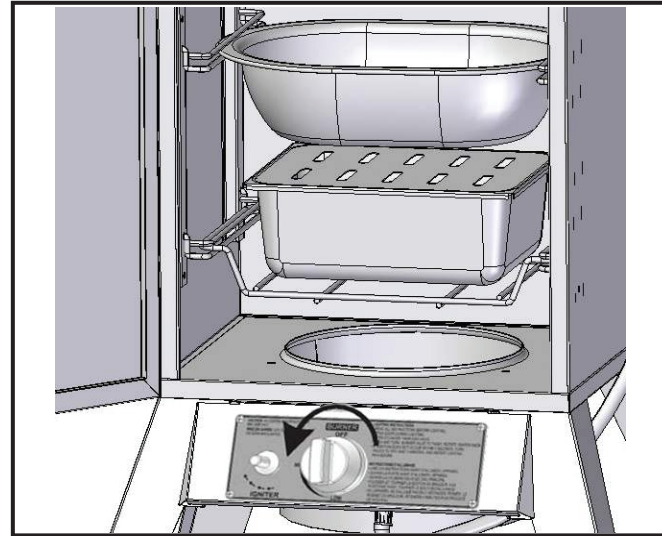

7. Immediately push the igniter button to click it several times (you should see a small spark jumping from the end of the electrode rod to the side of the burner). If the burner does not light within 3 to 5 seconds, turn the burner control knob OFF and wait five minutes before repeating the steps again. If burner still fails to light try match lighting the smoker using the instructions noted below.
8. Once the burner is lit, then close the door to allow heat to accumulate. The dampers can then be adjusted to the desired setting to allow proper air flow and combustion. Damper adjustment tips are listed on the next page.

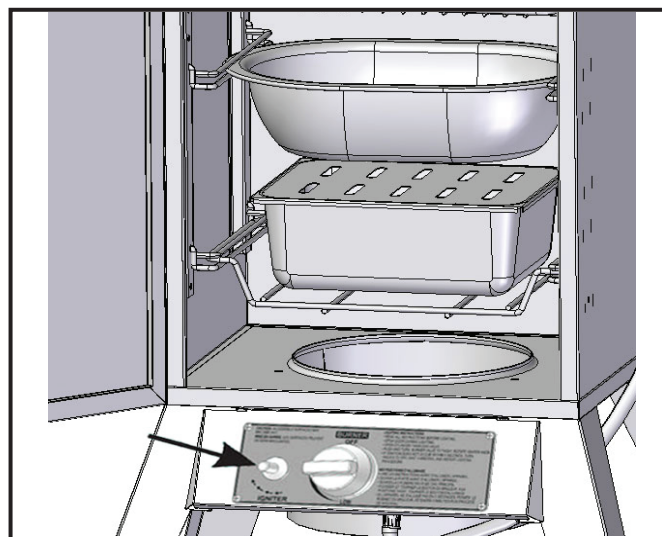

To match light the burner, repeat steps 1 thru 5 of the igniter lighting system above and continue with the following procedure:

Remove the wood box and its stand from inside the smoker. Strike a paper match and drop it into the burn chamber, next to the burner.

Quickly turn the control knob to the light position. If the burner does not light within 4 or 5 seconds, turn the control knob off, wait 5 minutes, and repeat the process.

If the burner flame is accidentally extinguished, turn the control knob off, wait 5 minutes, and repeat the lighting procedure.

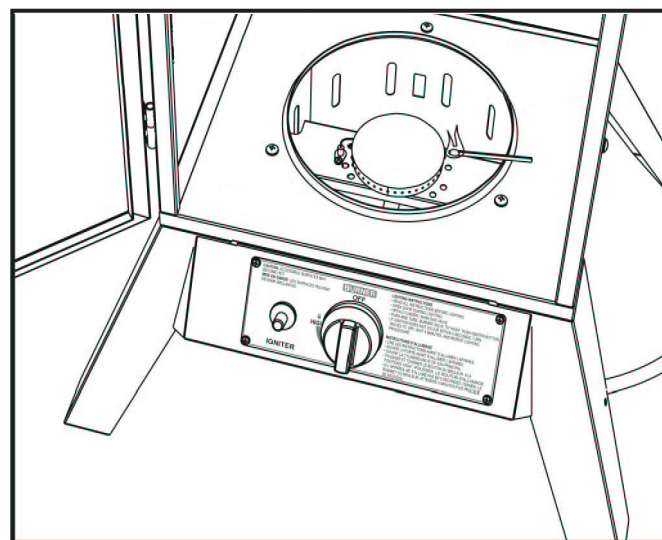



Operation: Cooking

Damper Adjustments

Temperature maintenance is best controlled by different damper adjustments. The key to effective smoking is to watch your heat indicator on the door and adjust the damper accordingly. For better performance, rotate the smoker to where the front of the cabinet is facing the wind. This allows the adjustment of the damper to be more effective and accurate.

Opening the damper helps to exhaust both the heat and smoke. The damper should never be fully closed.

Cooking Instructions

IMPORTANT: Before each use, clean and inspect the hose and the connection to the LP gas cylinder. If there is evidence of abrasion, wear, cuts or leaks, the hose must be replaced before the smoker is used. Refer to the “leak test” instructions in the LP Tank connection portion of this manual.

- Fill the wood chip box with flavoring wood chips and place the box inside the smoker as instructed in the assembly section of this manual. Refer to the section that explains flavoring wood for recommended use of flavoring wood.

- Place the water bowl inside the smoker in the lowest rack position as explained in the assembly section of this manual. Carefully fill the water bowl with water or marinade up to 1 inch below the rim. A full bowl will last for approximately 2-3 hours. Do not overfill or allow water to overflow from the water bowl.

- Insert or adjust the cooking grids in to the desired rack positions. For better access to the food with tongs or spatulas, make sure the grid wires run front to back as explained in the assembly section of this manual.

- You are now ready to light the burner. Refer to the Lighting Procedure on the previous pages of this manual. The heat from the burner will allow the wood chips to burn, causing the flavoring smoke to accumulate. Adjust the dampers to control the heat.

- Place the food on the cooking grids in a single layer with space between each piece. This will allow smoke and hot moisture to circulate evenly around all the food pieces.

- Smoking for 2 to 3 hours at the ideal constant cooking temperature of 225° to 250° F (110° to 120° C) will get the best results. This temperature is according to the heat indicator mounted on the front of the smoker. For more tender and heavily smoked meat, a lower temperature may be preferred. If time is critical, a higher temperature range is recommended.

- Check water level periodically and add water if low. For best results and to retain heat, avoid opening the door of the smoker while in use. When the door must be opened, only open it briefly. The smoker will quickly resume cooking temperature after the door is closed.

- Always use a meat probe thermometer to ensure food is fully cooked before removing it from the smoker.

- After each use, and after the smoker is cooled, carefully remove the water bowl from the smoker, empty the water, and clean the water bowl.

Shutting the Smoker Off

CAUTION: The smoker can become very hot while in use. Do not touch any portion of the smoker except for the door handle and burner control knob. It may be necessary to use protective gloves.

- Turn the burner control knob off by pushing in and rotating clockwise. The burner flame should then go out.

- Turn off the LP cylinder valve by turning the knob clockwise until it stops.

- Follow all warnings and safety precautions before removing meat from smoker or preparing the unit for storage. Please see page 23 for proper storage procedures and the important warnings and safeguards on pages 3 and 4.

Operation: Cooking



Temperature Chart

Refer to this USDA Standard chart for properly cooked meat temperature.

IMPORTANT: Measure the meat temperature using a meat probe thermometer. The heat indicator on the smoker gives the heat temperature inside the smoker cabinet, but is not an accurate measurement of the meat temperature.

	Fahrenheit (°F)	Celsius (°C)
Beef		
Rare	120°F - 125°F	45°C - 50°C
Medium-Rare	130°F - 135°F	55°C - 60°C
Medium	140°F - 145°F	60°C - 65°C
Medium-Well	150°F - 155°F	65°C - 70°C
Well Done	160°F - Higher	70°C - Higher
Lamb		
Rare	135°F	60°C
Medium-Rare	140°F - 150°F	60°C - 65°C
Medium	160°F	70°C
Well Done	165°F - Higher	75°C - Higher
Poultry		
Chicken	165°F - 175°F	75°C - 80°C
Turkey	165°F - 175°F	75°C - 80°C
Pork		
Fresh Pork (Raw)	160°F - 170°F	65°C - 70°C
Ham (Pre-Cooked)	140°F	60°C
Ham (Un-Cooked)	160°F	70°C
Fish		
(Cook until opaque and flaky)		



After Use Safety and Maintenance

⚠ DANGER

- Use caution when lifting and moving the smoker to avoid strains or back injury. 2 people are recommended to lift or move the smoker.
- DO NOT store the smoker near gasoline or other combustible liquids or where combustible vapors may be present. Keep the area around the smoker clear and free of combustible materials and vapors.
- DO NOT store this smoker in an area accessible to children or pets. Store the smoker in a dry, protected location.
- DO NOT allow anyone to conduct activities around the smoker following use until it has cooled. It is hot during operation and remains hot for a period of time following use.
- This smoker becomes extremely hot - allow the smoker to cool completely before handling. If you must handle the smoker while it is hot, ALWAYS wear protective oven mitts or heat resistant gloves when handling the smoker or its components. Allow the smoker to cool before removing and cleaning the grease pan.

Care and Maintenance to be performed before each use:

CAUTION: All care and maintenance procedures are to be performed only while the smoker is turned off and cooled.

Clean the water bowl and cooking grids with hot, soapy water. Rinse and dry thoroughly. You may prefer to coat the water bowl and cooking grids lightly with cooking oil or cooking spray.

Frequently check and clean the venturi and burner for insects and insect nests. A clogged tube can lead to fire outside the smoker. Also make sure the smoker does not have any foreign objects obstructing the flow of combustion and ventilation air.

To clean the inside and outside of the smoker cabinet, simply use a damp cloth. Spray-washing with a water hose is not recommended. All moisture should be wiped away and not allowed to stand inside or on top of the smoker. Once cleaned, you may prefer to lightly coat the interior of the smoker cabinet with cooking oil or cooking spray.

If rust is present on the exterior surface of the smoker, clean the area with steel wool or emery cloth and use heavy duty, heat resistant paint.

NEVER apply additional paint to the interior of the smoker. If rust is present on the interior of the smoker, clean it thoroughly with steel wool or emery cloth and lightly coat the area with cooking oil or cooking spray to help minimize recurring rust.

When an LP tank is not connected, and to help prevent dirt or other foreign particles from clogging the regulator, hang the end of the regulator hose from the side handle using the supplied S-hook.

During each use, inspect the flames at the burner. A good flame should be blue with a yellow tip about 1 inch in length. If flames are excessively yellow and irregular, oil residue and food deposits may be collecting on the burner. Try cleaning the burner surface and the holes to improve the flames. Bad flames may also be caused by poor regulator-to-venturi attachment. Always let the smoker cool before cleaning or checking the assembly.

To protect your smoker from weather, always keep your smoker covered while not in use.

Keep the area clear of all flammable liquids, combustible material including but not limited to wood, dry plants including grass, brush, paper, and canvas.

The smoker may be stored indoors only if the cylinder is disconnected and removed.

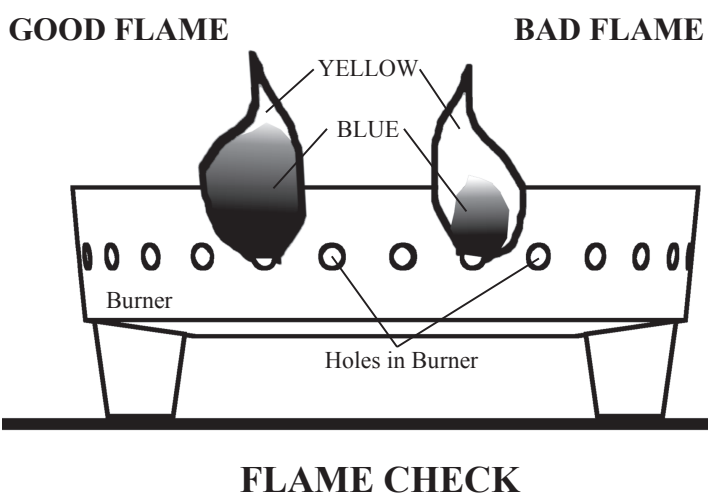

Limited Warranty



This Smoke Hollow™ smoker is guaranteed against broken or damaged parts at time of purchase. All parts carry a 1-year limited warranty with the exception of the water bowl, which is guaranteed to be free of defects for 90 days. Paint is guaranteed to be free of defects for 90 days except for rust, which may appear after repeated use.

This warranty does not cover damage or issues related to neglect, abuse, or modifications to the product. Repair labor is not covered.

All parts that meet the warranty requirements will be shipped at no-charge via the discretion of the Customer Service Department (ground shipments, US Mail, or Parcel Post ONLY). Any special handling charges (i.e. Second Day, Overnight, etc.) will be the responsibility of the consumer.

All warranty claims apply only to the original purchaser and require a proof of purchase verifying purchase date. Do not return parts to our address without first obtaining a return authorization number from our customer service.

This service is available by calling 866-475-5180, 8:30am to 4:30pm, Central Time, Monday through Friday, or write to Outdoor Leisure Products, Inc., 5400 Doniphan Drive, Neosho, MO 64850.

This warranty may give you specific legal rights that vary by state.

Outdoor Leisure Products, Inc.
5400 Doniphan Drive
Neosho, MO 64850

©2006 Outdoor Leisure Products, Inc. Smoke Hollow and the Smoke Hollow logo are trademarks of Outdoor Leisure Products, Inc. and are not to be used without express permission by Outdoor Leisure Products, Inc.

Part Number: 3A09000

Revision B: Oct. 2006