

ULTRACOOOL

Owner's Manual

Models

ADA35	ASA35
ADA50	ADA70
ASA50	ASA70
AUA50	AUA70
ADA50-12	ADA70-12
ASA50-12	ASA70-12
AUA50-12	AUA70-12



Circle the model of your cooler and record the serial number below.

Encierre con un círculo el modelo de su enfriador y escribe el número de serie abajo.

Serial #
Número De Serie _____

Read Carefully All Of This Manual Before Installing The Unit

Lea Con Cuidado Todo Este Manual Antes De Instalar La Unidad

Table Of Contents

Safety Instructions	1	Specification Tables (<i>Tablas de Especificaciones</i>)	5
Operation	2	Parts List (ADA35, ASA35)	6-7
Installation Instructions	2-3	Parts List (ADA50, ADA50-12, ADA70, ADA70-12)	8-9
Electrical Wiring Diagram	3	Parts List (ASA50, ASA50-12, ASA70, ASA70-12)	10-11
Maintenance Section	3-4	Parts List (AUA50, AUA70, AUA50-12, AUA70-12)	12-13
Troubleshooting	4	<i>Instrucciones en Español</i>	13-16
Warranty	5		

Vea el Español en el interior.

Read And Save These Instructions

Safety Rules

1. Read instructions carefully.
2. Electrical hook up should be done by a qualified electrician, so that all electrical wiring will conform to your local standards.
3. Always turn **OFF POWER** and **UNPLUG** motor and pump inside the cooler before installing or performing any maintenance.
4. Your cooler will run on either 120V or 240V A.C., single phase, 60 Hz (cycle) current.
5. Motor and pump have a grounded, molded plug and an automatic thermal overload switch which will shut motor off when it overheats. The motor will restart automatically when it cools down.

⚠ WARNING: To reduce the risk of fire or electric shock, do not use this fan with any "solid-state fan speed control device."

Evaporative Cooling

Evaporative cooling is nature's way of cooling. When air is moved over a wet surface, water is evaporated and heat is absorbed. When stepping out of swimming pool with the wind blowing, evaporative cooling makes you feel cool, even though the air may be warm.

This unit works on the same principle. Air is drawn across wet filter pads where the air is cooled by evaporation and then circulated throughout the building. It is this combination of cooled air and the movement of air over the skin which makes it feel cool.

Unlike refrigeration systems which recirculate the air, an evaporative cooler continually brings in fresh air while exhausting old air. You are completely replacing the air every 2 to 4 minutes by opening windows or doors or a combination of both. The air is always fresh, not stale, laden with smoke and odors as happens with refrigerated air conditioning.

Operation

To eliminate the delivery of hot air when starting the cooler, start the pump only for the first few minutes, then turn on the blower motor.

These coolers may be used without water for ventilation purposes. When outside air is cool (for example, at night) or when humidity is high the water pump can be turned off.

A cooler can also be installed with a thermostat and attic exhaust dampers to provide completely automatic operation.

Open Windows To Exhaust Air

An often misunderstood concept of evaporative cooling is the amount of air that should be exhausted. How much should you open your windows? The fact is that most people do not open their windows enough. The following two methods will help you determine the amount to open your windows.

First Method

You should allow an opening of at least 2 square feet (288 square inches) for each 1000 CFM rating of your unit. **Example:** At 3320 CFM, model ADA 50 (1/2 hp) requires 6.6 square feet (950 square inches) of opening ($3320/1000 * 2 = 6.6$). Multiply the number of windows by window width in inches and divide this into the number of square inches required for your size unit. This will give you the height to open windows. In this example, four 36 inch wide windows should be opened 6.6 inches each.

Champion Air Balancing Method

1. Take a piece of tissue paper and cut it lengthwise into 3 equal strips.
2. Turn your cooler on high cool.
3. Open one window at least six inches wide in each room that you want to cool.
4. Take the piece of tissue paper and put it up against the screen of the open window furthest from the cooler discharge opening. Let go of it. It will do one of three things.

IF It falls down.
THEN CLOSE all of the windows one inch and try step 4 again.

IF It plasters itself to the screen.
THEN OPEN all of the windows one inch and try step 4 again.

IF It stays on the screen lightly.
THEN PERFECT. You are done. Enjoy your cooler.

NOTES:

- When switching to low cool, you must rebalance your home. Repeat step 4.
- Once you balance your home you can cool some areas more than others by opening those windows more and closing the others by the same amount. Repeat step 4 to make sure your home is still air balanced.

Cooler Installation

⚠CAUTION: Make sure that the mounting surface is strong enough to support the operating weight of the cooler when in use. (For operating weight, see Specification Table.)

⚠CAUTION: Never plug in cooler until installation is complete and unit has been tested for rigidity.

⚠CAUTION: Do not screw or drill within 5 inches of the bottom of the wet module. You could puncture the reservoir.

NOTE: You can separate the wet module from the blower module by removing the 4 bolts (2 bolts in ADA35 and ASA35) from the wet module side (Fig. 1)

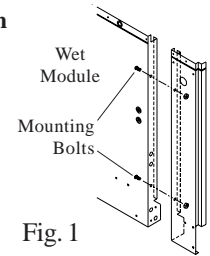

Fig. 1

Motor Installation

- **Install motor cord.** For typical 120V installation, connect motor cord to motor using the following color code: Black - Hi, Red - Low, White - Com., Green - Ground.

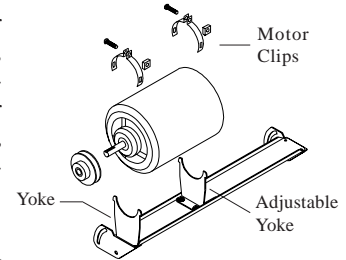

Fig. 2

- **Mount motor.** Install blower motor in the motor mount yokes, adjusting the yoke if necessary. Fasten with the provided mounting clips (see Fig. 2). **NOTE:** Adjustable yoke will have to be reversed for 1 H.P. motors.

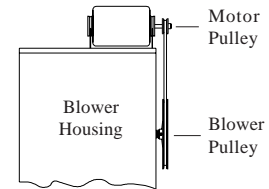

Fig. 3

- **Install pulley.** Install the adjustable motor pulley so that it aligns with the blower drive pulley (see Fig. 3) and tighten set screw.

Electrical Installation

⚠WARNING: Disconnect all electrical service that will be used for this unit before you begin the installation.

- **Remove junction box.** The electrical junction box is located in the upper inside of the left center post. Remove the two screws and pull box out from panel for access to plug wiring (Fig. 4).

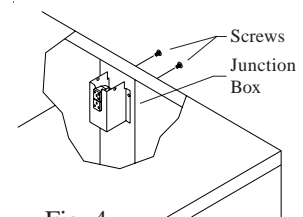

Fig. 4

- **Hook up electrical.** Electrical hook up should be done by a qualified electrician, so that all electrical wiring will conform to your local standards. This unit is supplied with a 120V pump. For 240V pump operation, a 240V pump must be purchased. The fan and pump receptacles will support both 120V and 240V installations. See the wiring diagrams for 120V and 240V installations on the following page.

IMPORTANT: When a single speed motor is used, do not use the red lead on the receptacle and motor plug wiring. Tape off end of both of the red leads.

⚠CAUTION: Pump receptacle is for grounded evaporative cooler pump only. Do not plug anything else into receptacle.

⚠WARNING: Make sure that cooler cabinet is properly grounded to a suitable ground connection for maximum safety.

Water Connection

- **Install overflow assembly.** Remove nut and place nipple through the hole in the pan, with the rubber washer between the pan and the head of the drain nipple (Fig. 6). Screw on nut and draw up tight against bottom of pan. Insert overflow pipe in nipple to retain

water. The overflow pipe may be removed to drain pan when necessary. A garden hose may be screwed on the drain nipple to drain water away from your unit.

- **Connect water supply line.** Install a sillcock and water valve on faucet as shown by figure 7. Place the nut and ferrule on the tubing and tighten the nut until water tight. **NOTE:** Do not connect the water supply to any soft water applications.

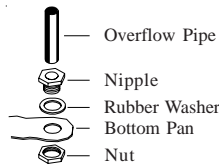

Fig. 6

- **Install float valve and fill pan.** Refer to Fig. 8. Remove items 1, 2, 3, and 4. Insert float body (5) through hole in back post panel as shown. Install washer (1) and nut (2). Tighten to keep float from turning. Place nut (4) and ferrule (3) on water supply line. Connect to float fitting and tighten until water tight. Loosen screw (6) and adjust rod (7) until water level is within 1" of top of reservoir. Tighten screw (6). Slide float shield (8) up over float body (5) until it snaps into place.

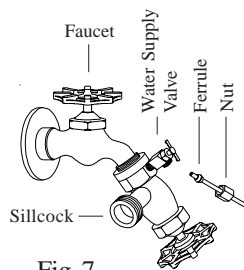

Fig. 7

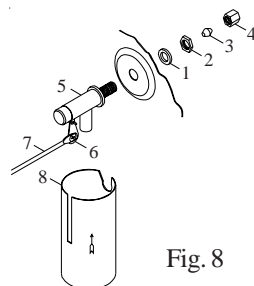

Fig. 8

working inside. This should be done for your safety. Adjust pulley to a larger diameter and readjust belt tension, plug motor in, install inspection panels, and retest amperage draw. Repeat this process until correct amperage draw is attained. Increasing motor pulley diameter increases amperage draw. Decreasing motor pulley diameter decreases amperage draw (see Fig. 9).

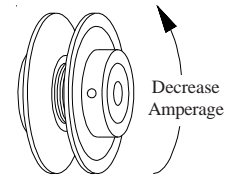

Fig. 9

⚠ CAUTION: Do not operate cooler with larger amperage draw than specified on motor plate.

NOTE: No attempt should be made to completely install this unit without the aid of an electrician or someone familiar with testing amperage draw. Failure to comply with these instructions may void your warranty.

Maintenance

⚠ WARNING: Before doing any maintenance be sure power is off. At the time you remove either inspection panel be sure to unplug motor and pump. This is for your safety.

Spring Start-Up

- **Clean pads.** A clean pad is more absorbent, efficient and will give more cool air. Annually, or when required, using a garden hose with nozzle, back wash to clean out the openings, then clean off the inlet face any scale or other obstruction to the passages. Slight scraping may be required to remove hardened scale.

- **Change pads if necessary.** The pads should be replaced after 5 years or if necessary. To change pads, remove top access panel, remove grill, and disconnect water delivery tube. Remove water distributor holder and lift out media sections. Replace with the same type media. You can purchase them from your dealer.

IMPORTANT: In order to get the best performance from your cooling pads, they must be installed properly. If you have purchased a pad with two equal angles, the following instructions can be disregarded. Pads must always be installed with the steeper flute angle sloping down towards the air entering side (Fig. 10). The reason is simple. The steeper angle puts more water on the hot, dry, dirty side of the pad where it is needed most. It also counteracts the tendency of the air to push the water toward the back of the pad.

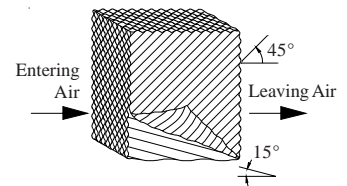

Fig. 10

Amperage Draw And Belt Tension

This unit is equipped with an adjustable motor drive sheave for adjusting the blower wheel speed to the proper loading on different duct systems. It is important that the motor drive pulley is adjusted to correct size to assure maximum air delivery without damage to the motor. Be sure to follow these instructions carefully.

- **Adjust drive pulley.** After the unit is completely installed, adjust the drive pulley to the least diameter and adjust belt tension. See the maintenance section for adjusting belt tension.
- **Start cooler.** Install both inspection panels, start pump, and allow to operate until pads are wet.
- **Check amperage.** With pads wet and unit started, check amperage draw with an amperage meter.
- **Adjust pulley if necessary.** If amperage draw is less than motor rating, turn off electrical power and remove inspection panels (top pan for models ADA35 and ASA35). Unplug motor inside cooler, this will protect you from someone turning on unit while you are

Wiring Diagrams

120 Volts

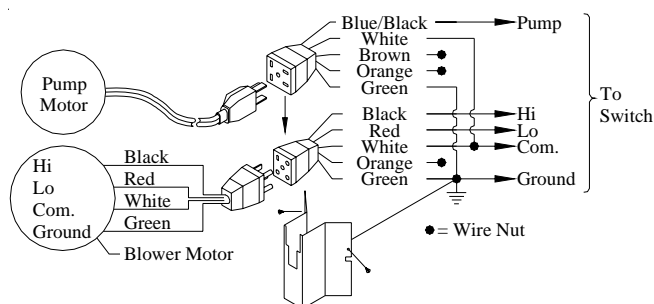

240 Volts

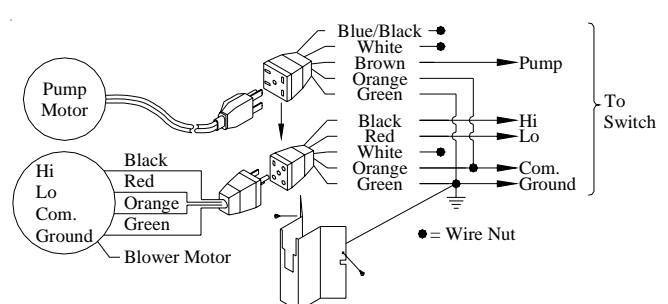

- **Check belt tension.** A 3 lb. force should deflect the belt 3/4 inches (see Fig. 11). Readjust belt if needed.

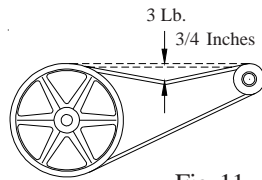

Fig. 11

- **Oil bearings.** The blower bearings and cooler motor in this unit should be oiled with a few drops of non-detergent 20/30 weight oil once each year. The motor does not need oil if it has no oil lines for oiling. Motors that have no oil lines are lifetime oiled at the factory and require no further oiling for the life of the unit.

CAUTION: Do not over oil. Over oiling can cause motor burn out, due to excessive oil getting into motor winding.

- **Clean pump.** Cleaning the pump is necessary once a year at start-up. For your safety, turn unit off and unplug motor and pump. Remove the pump from the mount slot. Remove the bottom cover of the pump as shown in Fig. 12. Clean the pump and turn the impeller to ensure free

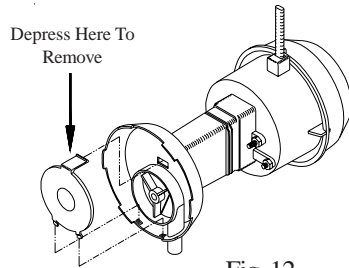

Fig. 12

operation. Remove the pump spout and check for any blockage. After cleaning, reinstall the cover onto the pump. Reattach the pump to the mount in the cooler using the plastic retainer to ensure that the pump will not overturn. Do not forget to replace the spout and water delivery tube onto the pump outlet. The pump has automatic reset thermal protection.

- **Check bleed-off valve to be sure it is not clogged.**

Winter Shut-Down

- **Drain water.** Always drain all of the water out of the cooler and water supply line when not in use for prolonged periods, and particularly at the end of the season. Keep the water line disconnected from both the unit and water supply so that it does not freeze.
- **Unplug motor and pump.** When cooler is not used for extended periods unplug the motor and pump from inside cooler.
- **Cover unit.** To protect the life of the finish, a cover for the unit is suggested in extended periods of non use.

By following the operating, installation, and maintenance suggestions as outlined, you can get many years of efficient and satisfactory service from your cooler. In the event additional information is desired, your dealer will be more than glad to assist you in every possible way.

Troubleshooting Guide

<u>Problem</u>	<u>Possible Cause</u>	<u>Remedy</u>
Failure to start or no air delivery	<ol style="list-style-type: none"> 1. No electrical power to unit <ul style="list-style-type: none"> • Fuse blown • Circuit breaker tripped • Electric cord damage 2. Belt too loose or tight 3. Motor overheated <ul style="list-style-type: none"> • Belt too tight • Blower bearings dry • Motor pulley diameter too large 4. Motor locked 	<ol style="list-style-type: none"> 1. Check power <ul style="list-style-type: none"> • Replace fuse • Re-set breaker • Replace cord 2. Adjust belt tension 3. Determine cause of overheating <ul style="list-style-type: none"> • Adjust belt tension • Oil blower bearings • Adjust pulley to correct diameter 4. Replace motor
Inadequate air delivery with cooler running	<ol style="list-style-type: none"> 1. Insufficient air exhaust 2. Belt too loose 3. Pads plugged 4. Motor underloaded 	<ol style="list-style-type: none"> 1. Open windows or doors to increase air flow 2. Adjust belt tension or replace if needed 3. Clean pads 4. Adjust pulley
Water draining onto roof	<ol style="list-style-type: none"> 1. Float arm not adjusted properly 2. Overflow assembly leaking 	<ol style="list-style-type: none"> 1. Adjust float 2. Tighten nut and overflow pipe
Musty or unpleasant odor	<ol style="list-style-type: none"> 1. Stale or stagnate water in cooler 	<ol style="list-style-type: none"> 1. Drain pan and clean pads

<u>Problem</u>	<u>Possible Cause</u>	<u>Remedy</u>
Motor cycles on and off	<ol style="list-style-type: none"> 1. Low voltage 2. Excessive belt tension 3. Blower shaft tight or locked 4. Bearings dry 5. Motor pulley diameter too large causing motor overload 	<ol style="list-style-type: none"> 1. Check voltage 2. Adjust belt tension 3. Oil or replace bearings (Unplug unit) 4. Oil bearings 5. Adjust pulley so full load ampere rating of motor is not exceeded
Noisy	<ol style="list-style-type: none"> 1. Bearings dry 2. Wheel rubbing blower housing 3. Loose parts 	<ol style="list-style-type: none"> 1. Oil bearings 2. Inspect and realign (Unplug unit) 3. Tighten loose parts
Inadequate cooling	<ol style="list-style-type: none"> 1. Inadequate exhaust in house 2. Pads not wet <ul style="list-style-type: none"> • Pads plugged • Dist. tube holes clogged • Pump not working properly 	<ol style="list-style-type: none"> 1. Open windows or doors to increase air flow 2. Check water distribution system <ul style="list-style-type: none"> • Clean pads • Clean • Replace or clean pump (Unplug unit)
Excessive humidity in house	<ol style="list-style-type: none"> 1. Insufficient air exhaust 	<ol style="list-style-type: none"> 1. Open doors or windows

Limited Warranty

This warranty is extended to the original purchaser of an evaporative cooler installed and used under normal conditions. It does not cover damages incurred through accident, neglect, or abuse by the owner. We do not authorize any person or representative to assume for us any other or different liability in connection with this product.

Terms And Conditions Of Warranty

Lifetime Limited Coverage on water reservoir against any leakage due to defects in material. From date of purchase, if any original component part provided by Champion Cooler fails due to defect in material or factory workmanship only, we will provide the replacement part as follows:

- One year on the cabinet components.
- Five years on the evaporative media.
- Two years on the original blower motor if furnished by Champion Cooler.

Exclusions From The Warranty

We are not responsible for any incidental or consequential damage resulting from any malfunction.

We are not responsible for any damage received from the use of water softeners, chemicals, descale material, plastic wrap, or if a motor of a higher horsepower than what is shown on the serial plate is used in the unit.

We are not responsible for the cost of service calls to diagnose cause of trouble, or labor charge to repair and/or replace parts.

How To Obtain Service Under This Warranty

Contact the Dealer where you purchased the evaporative cooler. If for any reason you are not satisfied with the response from the dealer, contact the Customer Service Department: Champion Cooler, 5800 Murray Street, Little Rock, Arkansas 72209. 1-800-643-8341. E-mail: info@championcooler.com.

This limited warranty applies to original purchaser only.

General Specifications / Especificaciones Generales

Models <i>Modelos</i>	Weight (lbs.) <i>Peso (libras)</i>		Cabinet Dimensions (in.) <i>Dimensiones De La Caja (pulgadas)</i>			Duct Opening (in.) <i>Abertura De Ducto (pulgadas)</i>	
	*Dry <i>Seco</i>	*Operating <i>Lleno</i>	Height <i>Altura</i>	Width <i>Anchura</i>	Depth <i>Profundidad</i>	Width <i>Anchura</i>	Height <i>Altura</i>
ADA35, ASA35	120	169	22 9/16	34	40	13 5/8	13 5/8
ADA50, ASA50, AUA50	165	230	28	42	45	17 3/4	17 3/4
ADA50-12, ASA50-12	175	250	28	42	49	17 3/4	17 3/4
ADA70, AS70, AUA70	198	265	34 5/8	42	48	19 3/4	19 3/4
ADA70-12, ASA70-12	217	292	34 5/8	42	52	19 3/4	19 3/4

* Does not include motor weight. / *No incluye el peso del motor.*

Motor Specifications / Especificaciones Del Motor

Models <i>Modelos</i>	HP <i>C.V.</i>	Motor # <i>Motor-N°</i>	Speed <i>Velocidad</i>	Volts <i>Voltios</i>	*Amps <i>Amperaje</i>	Weight (lbs.) <i>Peso (libras)</i>	Motor Pulley # <i>Polea Del Motor-N°</i>	Model <i>Modelo</i>	Drive Belt Part # <i>Correa - N°</i>
ADA35 & ASA35	1/3	110445	2	115	7.2	17	110279-001	ADA35	110209 (4L-430)
	1/2	110447	2	115	9.8	18		ASA35	110207 (4L-460)
	1/2	110475	2	230	4.9	15			
ADA50, ASA50, AUA50, ADA50-12 & ASA50-12	1/3	110445	2	115	7.2	17	110279-002	ADA50	110208 (4L-520) 110229 (4L-530) - 3/4 hp
	1/2	110447	2	115	9.8	18	110279-004	ASA50	110212 (4L-570)
	1/2	110475	2	230	4.9	15	110279-004	AUA50	110222 (4L-510)
	3/4	110449	2	115	13.8	22	110279-004	ADA50-12	110208 (4L-520)
	3/4	110480	2	230	6.9	21	110279-004		110229 (4L-530) - 3/4 hp
									ASA50-12
ADA70, ASA70, AUA70, ADA70-12 & ASA70-12	1/2	110447	2	115	9.8	18	110279-002	ADA70	110230 (4L-640)
	1/2	110475	2	230	4.9	15	110279-002	ASA70	110213 (4L-670)
	3/4	110449	2	115	13.8	22	110279-004	AUA70	110213 (4L-670)
	3/4	110480	2	230	6.9	21	110279-004	ADA70-12	110230 (4L-640)
	1	110471	2	115	16	29	110279-003		110230 (4L-640)
		1	110458	2	230	8	29	110279-003	ASA70-12

* Amperage shown is from National Electrical Code for high speed. / *Amperaje listado es del código eléctrico nacional para la velocidad alta.*

Replacement Parts List / *Lista De Piezas De Repuesto*

When ordering parts, please be sure to furnish the following information on all orders. Failure to do so may delay your order. /
Al pedir piezas, incluya toda la información siguiente con su pedido. El no proporcionar toda esta información resultará en una demora.

1. Cooler model number / *El modelo de su enfriador*
2. Cooler serial number / *Número de serie de la unidad*
3. Motor HP / *C.V. del motor*
4. Description and part number / *Descripción y número de pieza*
5. Date of purchase / *Fecha de compra*

No.	Description / Descripción	ADA35	ASA35
1.	Top, Blower Section / <i>Tapa De La Sección De La Rueda</i>	222130-028	222130-028
2.	Top, Wet Section / <i>Tapa De la Sección De Agua</i>	222130-029	222130-029
3.	Cabinet Wrapper, Blower Section / <i>Envoltura De Caja De La Sección De La Rueda</i>	322130-230	322130-130
4.	Cabinet Wrapper, Wet Section / <i>Envoltura De Caja De La Sección De Agua</i>	222130-032	222130-032
5.	Blower Housing / <i>Caja De La Rueda</i>	324106-104	324106-204
6.	Cut-Off Plate / <i>Placa Externa</i>	224002-003	224011-001
7.	Blower Wheel / <i>Rueda</i>	12BW	12BW
8.	Shaft, Blower Wheel / <i>Eje De La Rueda</i>	110182	110182
9.	Pulley, Blower Wheel / <i>Polea De La Rueda</i>	110274	110274
10.	Drive Belt / <i>Correa</i>	110209	110207
11.	Pulley, Motor / <i>Polea Del Motor</i>	110279-001	110279-001
12.	Motor / <i>Motor</i>	*	*
13.	Motor Mount Clips / <i>Seguros Para Montar Motor</i>	314005-001	314005-001
14.	Motor Mount / <i>Montura Del Motor</i>	314003-021	314003-020
15.	Electrical Cord, Motor (115V) / <i>Cable Eléctrico Del Motor (115V)</i>	110364	110364
15.	Electrical Cord, Motor (230V) / <i>Cable Eléctrico Del Motor (230V)</i>	110372-2	110372-2
16.	Bearings, Blower Wheel Shaft / <i>Cojinetes Del Eje De La Rueda</i>	110351	110351
17.	Electrical Junction Box / <i>Caja De Empalme</i>	322009-001	322009-001
18.	Receptacle, Motor / <i>Toma De Corriente Del Motor</i>	110393	110393
19.	Receptacle, Pump / <i>Toma De Corriente De La Bomba</i>	110361	110361
20.	Retainer, Bearing Mount / <i>Soporte Para La Montura De Los Cojinetes</i>	218002-008	218002-008
21.	Water Distributor Housing / <i>Caja Del Distribuidor De Agua</i>	281035	281035
22.	Media Shield / <i>Pantalla Protectora Para El Medio Evaporativo</i>	281025-005	281025-005
23.	Water Distributor Assembly / <i>Sistema Del Distribuidor De Agua</i>	3D-26	3D-26
24.	Water Distributor Bracket, Right / <i>Soporte Para El Distribuidor De Agua, Derecha</i>	222004-005	222004-005
24A.	Water Distributor Bracket, Left / <i>Soporte Para El Distribuidor De Agua, Izquierda</i>	222004-003	222004-003
25.	Evaporative Media / <i>Medio Evaporativo</i>	110103	110103
26.	Support, Media / <i>Soporte Para El Medio Evaporativo</i>	222130-027	222130-027
27.	Water Reservoir / <i>Bandeja Acumuladora De Agua</i>	281030	281030
28.	Pump Mount / <i>Montura De La Bomba</i>	216003-008	216003-008
29.	Pump Assembly / <i>Bomba</i>	C60P-120	C60P-120
30.	Pump Screen / <i>Malla Para La Bomba</i>	281001-001	281001-001
31.	Pump Retainer / <i>Sujetador De La Bomba</i>	110866N	110866N
32.	Float Valve / <i>Flotador</i>	FL-BK	FL-BK
33.	Float Shield / <i>Pantalla Protectora Del Flotador</i>	281005-001	281005-001
34.	Over Flow Assembly / <i>Montaje De Desagüe</i>	3OA-3	3OA-3
35.	Tube, Water Delivery / <i>Tubo De Agua</i>	110716	110716
37.	Anti-Flattening Coil / <i>Espiral Protectora</i>	110847	110847
38.	Grill / <i>Parrilla</i>	224115-001	224115-001
39.	Hobbs Polyester Pad / <i>Filtro De Poliester</i>	110119-1	110119-1
40.	Support Bracket / <i>Soporte Del Distribuidor</i>	220101-008	220101-008

* See the motor specification table on page 5. / *Vea la tabla de especificaciones del motor en la página 5.*

NOTE: Standard hardware items may be purchased from your local hardware store.

NOTA: *Artículos de uso corriente pueden comprarse en la ferretería de su localidad.*

Replacement Parts / Piezas De Repuesto

ADA35, ASA35

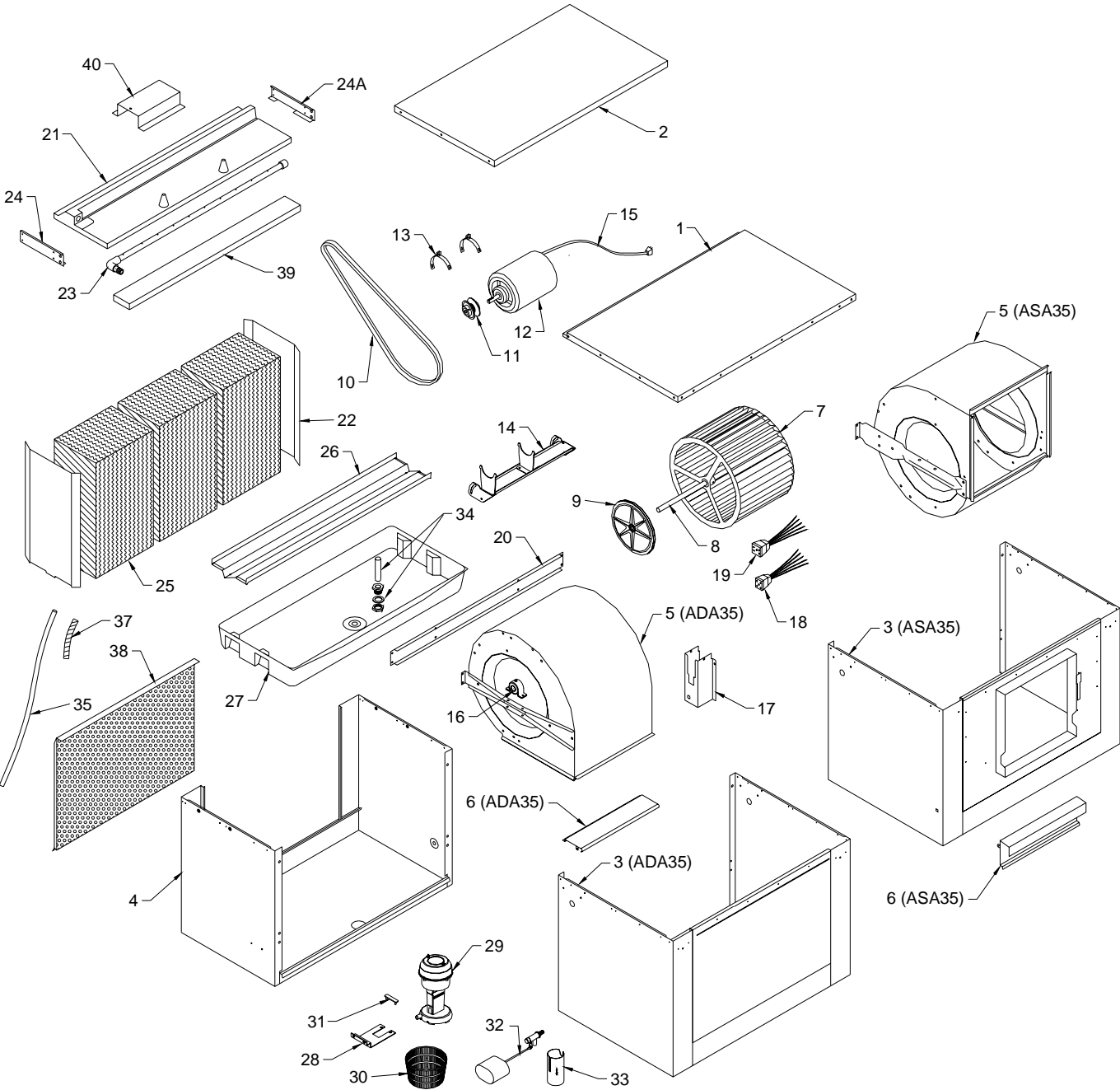

Replacement Parts List / *Lista De Piezas De Repuesto*

When ordering parts, please be sure to furnish the following information on all orders. Failure to do so may delay your order. /
Al pedir piezas, incluya toda la información siguiente con su pedido. El no proporcionar toda esta información resultará en una demora.

1. Cooler model number / *El modelo de su enfriador*
2. Cooler serial number / *Número de serie de la unidad*
3. Motor HP / *C.V. del motor*
4. Description and part number / *Descripción y número de pieza*
5. Date of purchase / *Fecha de compra*

No. N°	Description / Descripción	ADA50	ADA50-12	ADA70	ADA70-12
1.	Top, Cabinet / <i>Tapa De La Caja</i>	222130-035	222130-035	222140-018	222140-018
2.	Top Access Panel / <i>Panel Superior De Acceso</i>	222130-034	222130-045	222130-034	222130-045
3.	Bottom, Blower Section / <i>Base De La Sección De La Rueda</i>	322130-044	322130-044	322140-024	322140-024
4.	Bottom, Wet Module / <i>Base De La Sección De Agua</i>	222130-037	222130-047	222130-037	222130-047
5.	Front Panel / <i>Panel Del Frente</i>	222130-011	222130-011	222140-008	222140-008
6.	Inspection Panel / <i>Panel De Inspección</i>	222130-042	222130-042	222140-023	222140-023
7.	Center Post, Right / <i>Poste Central, Derecho</i>	222130-040	222130-040	222140-021	222140-021
8.	Center Post, Left / <i>Poste Central, Izquierdo</i>	222130-054	222130-054	222140-028	222140-028
9.	Back Post, Right / <i>Poste Trasero, Derecho</i>	222130-039	222130-048	222140-022	222140-025
10.	Back Post, Left / <i>Poste Trasero, Izquierdo</i>	222130-053	222130-056	222140-029	222140-030
11.	Blower Housing / <i>Caja De La Rueda</i>	324130-201	324130-201	324140-201	324140-201
12.	Cut-Off Plate / <i>Placa Externa</i>	224003-015	224003-015	224004-003	224004-003
13.	Motor Mount / <i>Montura Del Motor</i>	314003-011	314003-011	314003-012	314003-012
14.	Retainer, Blower Housing / <i>Soporte Para La Caja De La Rueda</i>	318002-104	318002-104	318002-104	318002-104
15.	Support, Media / <i>Soporte Para El Medio Evaporativo</i>	222130-008	222130-049	222130-008	222130-049
16.	Grill / <i>Parrilla</i>	222130-060	222130-060	222140-044	222140-044
17.	Electrical Junction Box / <i>Caja De Empalme</i>	322009-001	322009-001	322009-001	322009-001
18.	Motor Mount Clips / <i>Seguros Para Montar Motor</i>	314005-001	314005-001	314005-001	314005-001
19.	Float Shield / <i>Pantalla Protectora Del Flotador</i>	281005-001	281005-001	281005-001	281005-001
20.	Pump Screen / <i>Malla Para La Bomba</i>	281001-001	281001-001	281001-001	281001-001
22.	Media Shield / <i>Pantalla Protectora Para El Medio Evaporativo</i>	281025-001	281025-003	281025-002	281025-004
23.	Water Distributor Housing / <i>Caja Del Distribuidor De Agua</i>	281038	281033	281038	281033
24.	Water Reservoir / <i>Bandeja Acumuladora De Agua</i>	281031	281032-001	281031	281032-001
25.	Water Distributor Tube / <i>Tubo Del Distribuidor De Agua</i>	3D-23	3D-23	3D-23	3D-23
26.	Evaporative Media / <i>Medio Evaporativo</i>	110099	110108	110104	110109
27.	Over Flow Assembly / <i>Montaje De Desagüe</i>	30A-1	30A-1	30A-1	30A-1
28.	Float Valve / <i>Flotador</i>	FL-BK	FL-BK	FL-BK	FL-BK
29.	Pump Assembly / <i>Bomba</i>	C60P-120	C60P-120	C60P-120	C60P-120
30.	Tube, Water Delivery / <i>Tubo De Agua</i>	310716	310716	310716	310716
31.	Bleed-Off Kit / <i>Equipo De La Válvula De Desahogo</i>	310586	310586	310586	310586
32.	Receptacle, Motor / <i>Toma De Corriente Del Motor</i>	110393	110393	110393	110393
33.	Receptacle, Pump / <i>Toma De Corriente De La Bomba</i>	110361	110361	110361	110361
34.	Blower Wheel / <i>Rueda</i>	16BW	16BW	20BW	20BW
35.	Shaft, Blower Wheel / <i>Eje De La Rueda</i>	110183	110183	110183	110183
36.	Pulley, Blower Wheel / <i>Polea De La Rueda</i>	110275	110275	110276	110276
37.	Drive Belt / <i>Correa</i>	*	*	*	*
38.	Bearings, Blower Wheel Shaft / <i>Cojinetes Del Eje De La Rueda</i>	110351	110351	110351	110351
39.	Motor / <i>Motor</i>	*	*	*	*
40.	Pulley, Motor / <i>Polea Del Motor</i>	*	*	*	*
41.	Electrical Cord, Motor (115V) / <i>Cable Eléctrico Del Motor (115V)</i>	110372	110372	110372	110372
41.	Electrical Cord, Motor (230V) / <i>Cable Eléctrico Del Motor (230V)</i>	110372-2	110372-2	110372-2	110372-2
42.	Water Distributor Bracket, Right / <i>Soporte Del Distribuidor De Agua, Derecha</i>	222004-004	222004-006	222004-004	222004-006
42A.	Water Distributor Bracket, Left / <i>Soporte Del Distribuidor De Agua, Izquierda</i>	222004-001	222004-002	222004-001	222004-002
43.	Anti-Flattening Coil / <i>Espiral Protectora</i>	110847	110847	110847	110847
44.	Pump Mount / <i>Montura De La Bomba</i>	216003-008	216003-008	216003-008	216003-008
45.	Pump Retainer / <i>Sujetador De La Bomba</i>	110866N	110866N	110866N	110866N
46.	Support Bracket / <i>Soporte Del Distribuidor</i>	220101-007	220101-007	220101-007	220101-007
47.	Hobbs Polyester Pad / <i>Filtro De Poliester</i>	110119	110119	110119	110119

* See the motor specification table on page 5. / *Vea la tabla de especificaciones del motor en la página 5.*

NOTE: Standard hardware items may be purchased from your local hardware store.

NOTA: Artículos de uso corriente pueden comprarse en la ferretería de su localidad.

Replacement Parts / Piezas De Repuesto

ADA50, ADA50-12, ADA70, ADA70-12

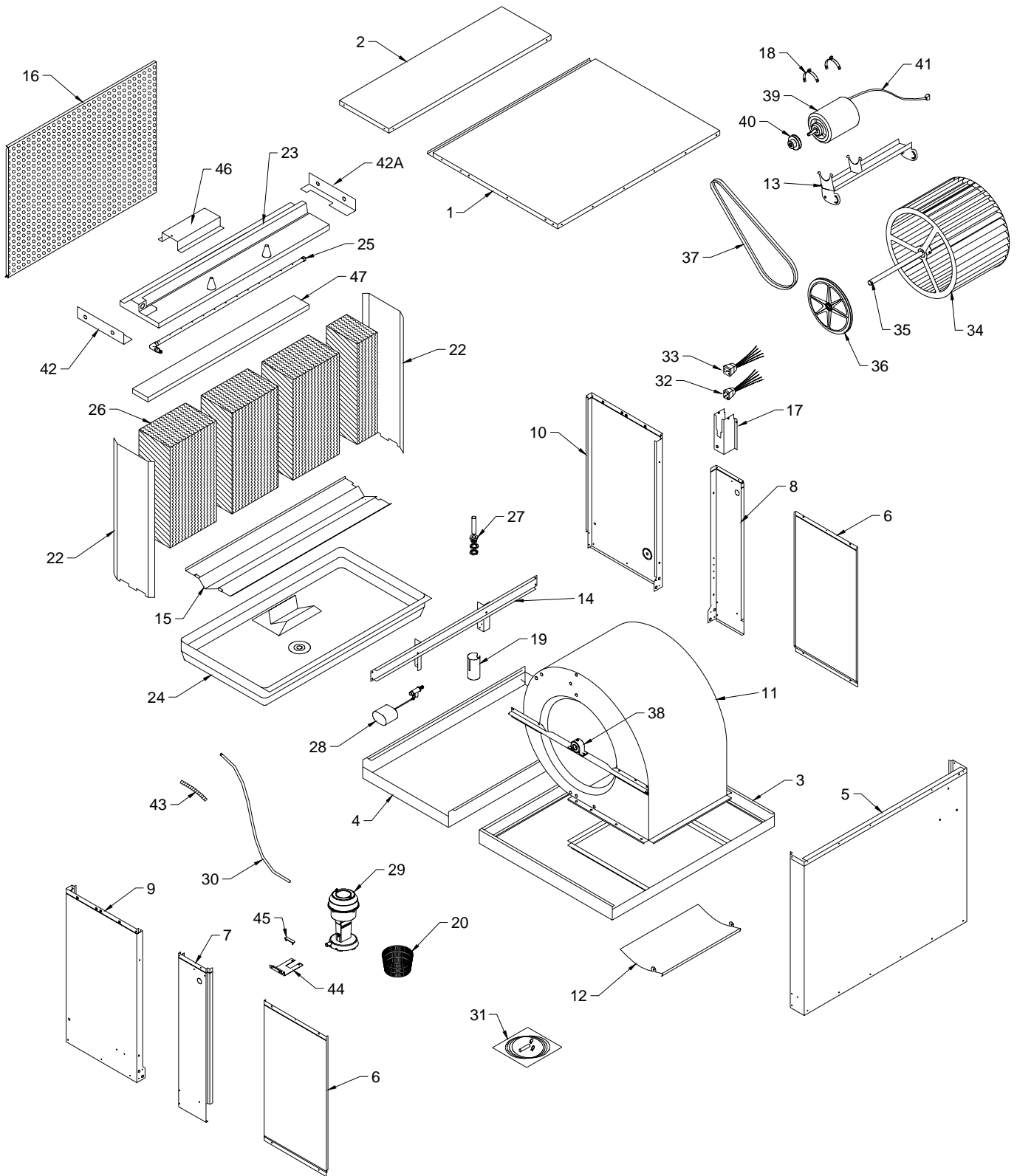

Replacement Parts List / *Lista De Piezas De Repuesto*

When ordering parts, please be sure to furnish the following information on all orders. Failure to do so may delay your order. /
Al pedir piezas, incluya toda la información siguiente con su pedido. El no proporcionar toda esta información resultará en una demora.

1. Cooler model number / *El modelo de su enfriador*
2. Cooler serial number / *Número de serie de la unidad*
3. Motor HP / *C.V. del motor*
4. Description and part number / *Descripción y número de pieza*
5. Date of purchase / *Fecha de compra*

No.	<u>Description / Descripción</u>	<u>ASA50</u>	<u>ASA50-12</u>	<u>ASA70</u>	<u>ASA70-12</u>
1.	Top, Cabinet / <i>Tapa De La Caja</i>	222130-035	222130-035	222140-018	222140-018
2.	Top Access Panel / <i>Panel Superior De Acceso</i>	222130-034	222130-045	222130-034	222130-045
3.	Bottom, Blower Section / <i>Base De La Sección De La Rueda</i>	222130-038	222130-038	222140-020	222140-020
4.	Bottom, Wet Module / <i>Base De La Sección De Agua</i>	222130-037	222130-047	222130-037	222130-047
5.	Front Panel / <i>Panel Del Frente</i>	322130-012	322130-012	322140-007	322140-007
6.	Inspection Panel / <i>Panel De Inspección</i>	222130-042	222130-042	222140-023	222140-023
7.	Center Post, Right / <i>Poste Central, Derecho</i>	222130-040	222130-040	222140-021	222140-021
8.	Center Post, Left / <i>Poste Central, Izquierdo</i>	222130-054	222130-054	222140-028	222140-028
9.	Back Post, Right / <i>Poste Trasero, Derecho</i>	222130-039	222130-048	222140-022	222140-025
10.	Back Post, Left / <i>Poste Trasero, Izquierdo</i>	222130-053	222130-056	222140-029	222140-030
11.	Blower Housing / <i>Caja De La Rueda</i>	324130-210	324130-210	324140-210	324140-210
12.	Cut-Off Plate / <i>Placa Externa</i>	224003-015	224003-015	224004-003	224004-003
13.	Motor Mount / <i>Montura Del Motor</i>	314003-011	314003-011	314003-012	314003-012
14.	Retainer, Bearing Mount / <i>Soporte Para La Montura De Los Cojinetes</i>	218002-004	218002-004	218002-009	218002-009
15.	Support, Media / <i>Soporte Para El Medio Evaporativo</i>	222130-008	222130-049	222130-008	222130-049
16.	Grill / <i>Parrilla</i>	222130-060	222130-060	222140-044	222140-044
17.	Electrical Junction Box / <i>Caja De Empalme</i>	322009-001	322009-001	322009-001	322009-001
18.	Motor Mount Clips / <i>Seguros Para Montar Motor</i>	314005-001	314005-001	314005-001	314005-001
19.	Float Shield / <i>Pantalla Protectora Del Flotador</i>	281005-001	281005-001	281005-001	281005-001
20.	Pump Screen / <i>Malla Para La Bomba</i>	281001-001	281001-001	281001-001	281001-001
22.	Media Shield / <i>Pantalla Protectora Para El Medio Evaporativo</i>	281025-001	281025-003	281025-002	281025-004
23.	Water Distributor Housing / <i>Caja Del Distribuidor De Agua</i>	281038	281033	281038	281033
24.	Water Reservoir / <i>Bandeja Acumuladora De Agua</i>	281031	281032-001	281031	281032-001
25.	Water Distributor Tube / <i>Tubo Del Distribuidor De Agua</i>	3D-23	3D-23	3D-23	3D-23
26.	Evaporative Media / <i>Medio Evaporativo</i>	110099	110108	110104	110109
27.	Over Flow Assembly / <i>Montaje De Desagüe</i>	30A-1	30A-1	30A-1	30A-1
28.	Float Valve / <i>Flotador</i>	FL-BK	FL-BK	FL-BK	FL-BK
29.	Pump Assembly / <i>Bomba</i>	C60P-120	C60P-120	C60P-120	C60P-120
30.	Tube, Water Delivery / <i>Tubo De Agua</i>	310716	310716	310716	310716
31.	Bleed-Off Kit / <i>Equipo De La Válvula De Desahogo</i>	310586	310586	310586	310586
32.	Receptacle, Motor / <i>Toma De Corriente Del Motor</i>	110393	110393	110393	110393
33.	Receptacle, Pump / <i>Toma De Corriente De La Bomba</i>	110361	110361	110361	110361
34.	Blower Wheel / <i>Rueda</i>	16BW	16BW	20BW	20BW
35.	Shaft, Blower Wheel / <i>Eje De La Rueda</i>	110183	110183	110183	110183
36.	Pulley, Blower Wheel / <i>Polea De La Rueda</i>	110275	110275	110276	110276
37.	Drive Belt / <i>Correa</i>	*	*	*	*
38.	Bearings, Blower Wheel Shaft / <i>Cojinetes Del Eje De La Rueda</i>	110351	110351	110351	110351
39.	Motor / <i>Motor</i>	*	*	*	*
40.	Pulley, Motor / <i>Polea Del Motor</i>	*	*	*	*
41.	Electrical Cord, Motor (115V) / <i>Cable Eléctrico Del Motor (115V)</i>	110372	110372	110372	110372
41.	Electrical Cord, Motor (230V) / <i>Cable Eléctrico Del Motor (230V)</i>	110372-2	110372-2	110372-2	110372-2
42.	Water Distributor Bracket, Right / <i>Soporte Del Distribuidor De Agua, Derecha</i>	222004-004	222004-006	222004-004	222004-006
42A.	Water Distributor Bracket, Left / <i>Soporte Del Distribuidor De Agua, Izquierda</i>	222004-001	222004-002	222004-001	222004-002
43.	Anti-Flattening Coil / <i>Espiral Protectora</i>	110847	110847	110847	110847
44.	Pump Mount / <i>Montura De La Bomba</i>	216003-008	216003-008	216003-008	216003-008
45.	Pump Retainer / <i>Sujetador De La Bomba</i>	110866N	110866N	110866N	110866N
46.	Support Bracket / <i>Soporte Del Distribuidor</i>	220101-007	220101-007	220101-007	220101-007
47.	Hobbs Polyester Pad / <i>Filtro De Poliester</i>	110119	110119	110119	110119

* See the motor specification table on page 5. / *Vea la tabla de especificaciones del motor en la página 5.*

NOTE: Standard hardware items may be purchased from your local hardware store.

NOTA: Artículos de uso corriente pueden comprarse en la ferretería de su localidad.

Replacement Parts / Piezas De Repuesto

ASA50, ASA50-12, ASA70, ASA70-12

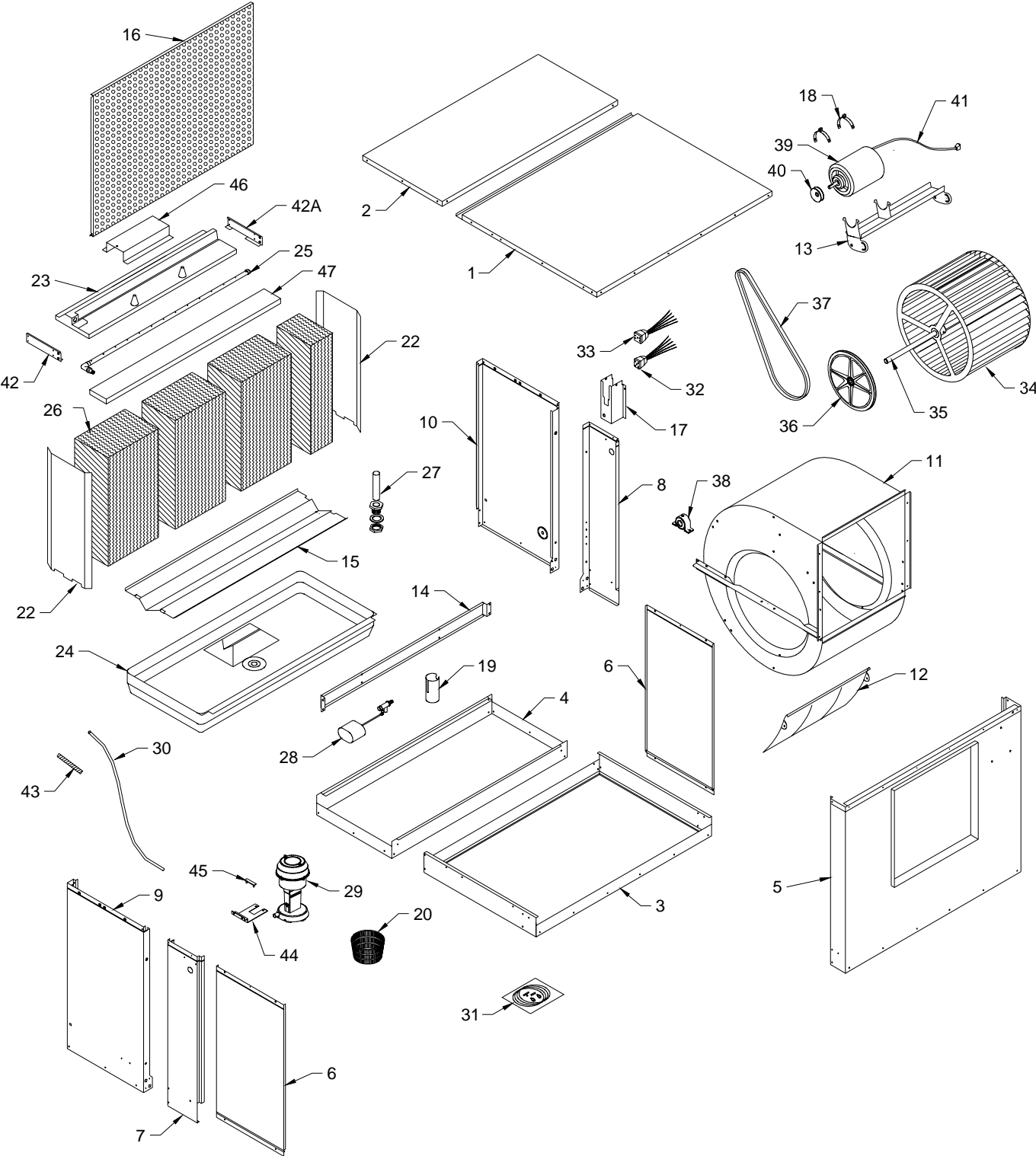

Replacement Parts List / *Lista De Piezas De Repuesto*

When ordering parts, please be sure to furnish the following information on all orders. Failure to do so may delay your order. /
Al pedir piezas, incluya toda la información siguiente con su pedido. El no proporcionar toda esta información resultará en una demora.

1. Cooler model number / *El modelo de su enfriador*
2. Cooler serial number / *Número de serie de la unidad*
3. Motor HP / *C.V. del motor*
4. Description and part number / *Descripción y número de pieza*
5. Date of purchase / *Fecha de compra*

No.	<u>Description / Descripción</u>	<u>AUA50</u>	<u>AUA50-12</u>	<u>AUA70</u>	<u>AUA70-12</u>
1.	Top, Cabinet / <i>Tapa De La Caja</i>	322130-036	322130-036	322140-019	322140-019
2.	Top Access Panel / <i>Panel Superior De Acceso</i>	222130-020	222130-046	222130-020	222130-046
3.	Bottom, Blower Section / <i>Base De La Sección De La Rueda</i>	222130-038	222130-038	222140-020	222140-020
4.	Bottom, Wet Module / <i>Base De La Sección De Agua</i>	222130-037	222130-047	222130-037	222130-047
5.	Front Panel / <i>Panel Del Frente</i>	222130-023	222130-023	222140-017	222140-017
6.	Inspection Panel / <i>Panel De Inspección</i>	222130-043	222130-043	222140-023	222140-023
7.	Center Post, Right / <i>Poste Central, Derecho</i>	222130-041	222130-041	222140-021	222140-021
8.	Center Post, Left / <i>Poste Central, Izquierdo</i>	222130-055	222130-055	222140-028	222140-028
9.	Back Post, Right / <i>Poste Trasero, Derecho</i>	222130-039	222130-048	222140-022	222140-025
10.	Back Post, Left / <i>Poste Trasero, Izquierdo</i>	222130-053	222130-056	222140-029	222140-030
11.	Blower Housing / <i>Caja De La Rueda</i>	324130-101	324130-101	324140-110	324140-110
12.	Cut-Off Plate / <i>Placa Externa</i>	224003-015	224003-015	224004-003	224004-003
13.	Motor Mount / <i>Montura Del Motor</i>	314003-011	314003-011	314003-012	314003-012
14.	Retainer, Bearing Mount / <i>Soporte Para La Montura De Los Cojinetes</i>	218002-005	218002-005	218002-005	218002-005
15.	Support, Media / <i>Soporte Para El Medio Evaporativo</i>	222130-008	222130-049	222130-008	222130-049
16.	Grill / <i>Parrilla</i>	222130-060	222130-060	222140-044	222140-044
17.	Electrical Junction Box / <i>Caja De Empalme</i>	322009-001	322009-001	322009-001	322009-001
18.	Motor Mount Clips / <i>Seguros Para Montar Motor</i>	314005-001	314005-001	314005-001	314005-001
19.	Float Shield / <i>Pantalla Protectora Del Flotador</i>	281005-001	281005-001	281005-001	281005-001
20.	Pump Screen / <i>Malla Para La Bomba</i>	281001-001	281001-001	281001-001	281001-001
22.	Media Shield / <i>Pantalla Protectora Para El Medio Evaporativo</i>	281025-001	281025-003	281025-002	281025-004
23.	Water Distributor Housing / <i>Caja Del Distribuidor De Agua</i>	281038	281033	281038	281033
24.	Water Reservoir / <i>Bandeja Acumuladora De Agua</i>	281031	281032-001	281031	281032-001
25.	Water Distributor Tube / <i>Tubo Del Distribuidor De Agua</i>	3D-23	3D-23	3D-23	3D-23
26.	Evaporative Media / <i>Medio Evaporativo</i>	110099	110108	110104	110109
27.	Over Flow Assembly / <i>Montaje De Desagüe</i>	3OA-1	3OA-1	3OA-1	3OA-1
28.	Float Valve / <i>Flotador</i>	FL-BK	FL-BK	FL-BK	FL-BK
29.	Pump Assembly / <i>Bomba</i>	C60P-120	C60P-120	C60P-120	C60P-120
30.	Tube, Water Delivery / <i>Tubo De Agua</i>	310716	310716	310716	310716
31.	Bleed-Off Kit / <i>Equipo De La Válvula De Desahogo</i>	310586	310586	310586	310586
32.	Receptacle, Motor / <i>Toma De Corriente Del Motor</i>	110393	110393	110393	110393
33.	Receptacle, Pump / <i>Toma De Corriente De La Bomba</i>	110361	110361	110361	110361
34.	Blower Wheel / <i>Rueda</i>	16BW	16BW	20BW	20BW
35.	Shaft, Blower Wheel / <i>Eje De La Rueda</i>	110183	110183	110183	110183
36.	Pulley, Blower Wheel / <i>Polea De La Rueda</i>	110275	110275	110276	110276
37.	Drive Belt / <i>Correa</i>	*	*	*	*
38.	Bearings, Blower Wheel Shaft / <i>Cojinetes Del Eje De La Rueda</i>	110351	110351	110351	110351
39.	Motor / <i>Motor</i>	*	*	*	*
40.	Pulley, Motor / <i>Polea Del Motor</i>	*	*	*	*
41.	Electrical Cord, Motor (115V) / <i>Cable Eléctrico Del Motor (115V)</i>	110372	110372	110372-1	110372-1
41.	Electrical Cord, Motor (230V) / <i>Cable Eléctrico Del Motor (230V)</i>	110372-2	110372-2	110372-2	110372-2
42.	Water Distributor Bracket, Right / <i>Soporte Del Distribuidor De Agua, Derecha</i>	222004-004	222004-006	222004-004	222004-006
42A.	Water Distributor Bracket, Left / <i>Soporte Del Distribuidor De Agua, Izquierda</i>	222004-001	222004-002	222004-001	222004-002
43.	Anti-Flattening Coil / <i>Espiral Protectora</i>	110847	110847	110847	110847
44.	Pump Mount / <i>Montura De La Bomba</i>	216003-008	216003-008	216003-008	216003-008
45.	Pump Retainer / <i>Sujetador De La Bomba</i>	110866N	110866N	110866N	110866N
46.	Support Bracket / <i>Soporte Del Distribuidor</i>	220101-007	220101-007	220101-007	220101-007
47.	Hobbs Polyester Pad / <i>Filtro De Poliester</i>	110119	110119	110119	110119

* See the motor specification table on page 5. / *Vea la tabla de especificaciones del motor en la página 5.*

NOTE: Standard hardware items may be purchased from your local hardware store.

NOTA: Artículos de uso corriente pueden comprarse en la ferretería de su localidad.

Replacement Parts / Piezas De Repuesto

AUA50, AUA50-12, AUA70, AUA70-12

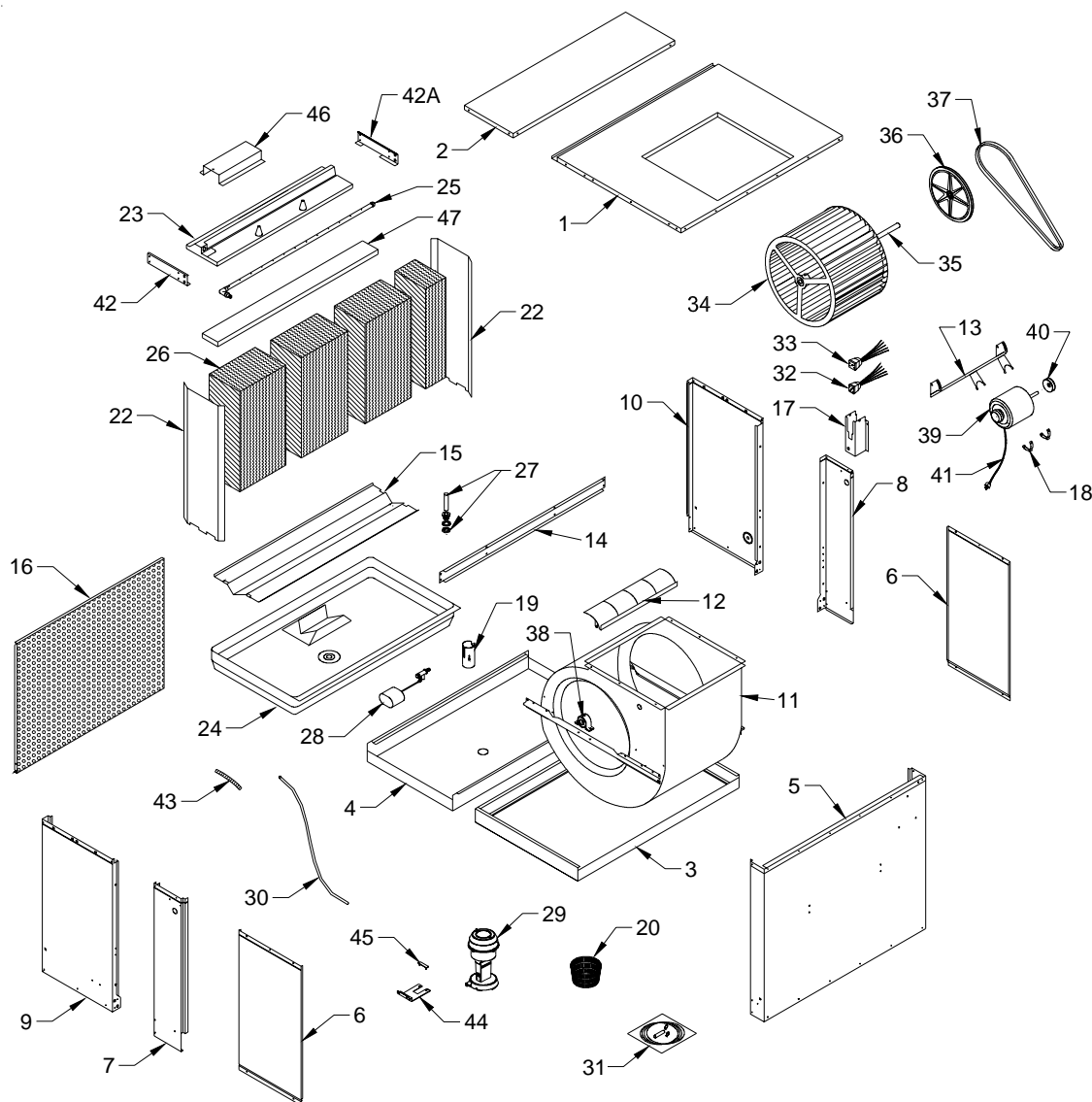

Lea Y Conserve Estas Instrucciones

Reglas De Seguridad

1. Lea las instrucciones con cuidado.
2. Las conexiones eléctricas deben ser hechas por un electricista competente, para que todo el cableado eléctrico cumpla con los requisitos establecidos en su localidad.
3. Siempre **CORTE LA CORRIENTE** y **DESCONECTE** el motor y la bomba en el interior del aparato antes de instalar o realizar cualquier labor de mantenimiento.
4. Su enfriador funciona con corriente alterna de 120V o 240V, de una fase y 60 Hz. (ciclos).
5. El motor y la bomba están provistos de clavijas moldeadas, con toma de tierra, y se apagarán automáticamente en caso de sobrecalentamiento. Los motores volverán a funcionar cuando se enfrían.

⚠ADVERTENCIA: Para reducir el riesgo de incendio o toques eléctricos, no use este ventilador con ningún "dispositivo de estado sólido para controlar la velocidad del ventilador."

Enfriamiento Por Evaporación

Este enfriador evaporativo funciona circulando el aire fresco; Usted no tiene aire recirculado que esté viciado, cargado de humo y olores como ocurre con los sistemas de aire acondicionado a base de refrigeración. En cambio, se reemplaza el aire completamente cada 2 a 4 minutos, abriendo las puertas o las ventanas o una combinación de ambas para agotar el aire continuamente.

Operación

Para que no salga aire caliente al principio, prenda sólo la bomba durante unos cuantos minutos; luego prenda también el motor del ventilador.

Su unidad puede ser utilizada sin agua para proporcionar ventilación solamente. Cuando hace fresco (por ejemplo, de noche) o cuando la humedad es alta, la bomba de agua puede ser apagada.

La unidad puede ser instalada también con termostato y reguladores de escape en el ático para obtener un funcionamiento totalmente automático.