

---

# OWNER'S MANUAL

---



CHAMPION

WC 33  
WC 42  
WC 47

**CIRCLE THE MODEL OF YOUR COOLER AND RECORD THE SERIAL NUMBER BELOW.**

*ENCIERRE CON UN CIRCULO EL MODELO DE SU APARATO Y ESCRIBE EL NUMERO DE SERIE ABAJO.*

**SERIAL #**

NUMERO DE SERIE \_\_\_\_\_



**READ CAREFULLY ALL OF THIS MANUAL BEFORE INSTALLING THE UNIT**

*LEA CON CUIDADO TODO ESTE MANUAL ANTES DE INSTALAR LA UNIDAD*

---

**READ AND SAVE THESE INTRUCTIONS**

*VEA EL ESPAÑOL EN EL INTERIOR.*

## SAFETY RULES

1. Read instructions carefully.
2. Electrical hook up should be done by a qualified electrician, so that all electrical wiring will conform to your local standards.
3. Unit must be in the **OFF POSITION** and **UNPLUGGED** from power receptacle when installing or performing any maintenance.
4. Your cooler will run on 120 volt A.C., 60 Hz (cycle) current only.
5. Motor and pump are grounded and have an automatic thermal overload switch which will shut motor off when it overheats. The motor will restart automatically when it cools down.

**⚠ WARNING:** To reduce the risk of fire or electric shock, do not use this fan with any "solid-state fan speed control device."

## EVAPORATIVE COOLING

With this unit being a fresh air system, you are not trapped with recirculating air that can become stale, laden with smoke and odors, as happens with refrigerated air conditioning systems. Instead, you are completely replacing the air every 2 to 4 minutes by either opening doors or windows or a combination of both to exhaust the air continually.

## OPERATION

To eliminate delivery of hot air when starting cooler, turn on pump only for the first few minutes, then turn on the blower motor.

These coolers may be used without water for ventilation purposes. When outside air is cool (for example, at night) or when humidity is high the water pump can be turned off.

## OPEN WINDOWS TO EXHAUST AIR

An often misunderstood concept of evaporative cooling is the amount of air that should be exhausted. How much should you open your windows? The fact is that most people do not open their windows enough. The following method will help you determine the amount to open your windows.

### CHAMPION AIR BALANCING METHOD

1. Take a piece of tissue paper and cut it lengthwise into 3 equal strips.
2. Turn your cooler on high cool.
3. Open one window at least six inches wide in each room that you want to cool.
4. Take the piece of tissue paper and put it up against the screen of the open window furthest from the cooler discharge opening. Let go of it. It will do one of three things.

*IF* It falls down.  
*THEN* CLOSE all of the windows one inch and try step 4 again.

*IF* It plasters itself to the screen.  
*THEN* OPEN all of the windows one inch and try step 4 again.

*IF* It stays on the screen lightly.  
*THEN* PERFECT. You are done. Enjoy your cooler.

#### NOTES:

- When switching to low cool, you must rebalance your home. Repeat step 4.
- Once you balance your home you can cool some areas more than others by opening those windows more and closing the others by the same amount. Repeat step 4 to make sure your home is still air balanced.

## COOLER INSTALLATION

### MOUNTING COOLER

**⚠ CAUTION:** Make sure that the mounting surface is strong enough to support the operating weight of the cooler when in use. (For operating weight, see Specification Table.)

**⚠ CAUTION:** Never plug in cooler until installation is complete and unit has been tested for rigidity.

- **Lift out all removable louvered sides.**
- **Screw chain hooks into window facing.** Position the two chain hooks above the neck of the cooler a distance equal to the width of the cooler apart (A-Fig. 1). Hook one hanger chain in each hook and then one turnbuckle in other end of each chain. **NOTE:** Chain hooks supplied with this mounting kit have wood screw threads for wood walls. Concrete, brick walls or concrete blocks require sufficiently strong wing nuts or anchors with mating hooks.

- **Install window panel retainers.** Place two panel retainer strips onto bottom of neck flange and position to the width of the window. Cut the strips to fit if necessary. These strips hold the window fill-in panels (Fig. 2).

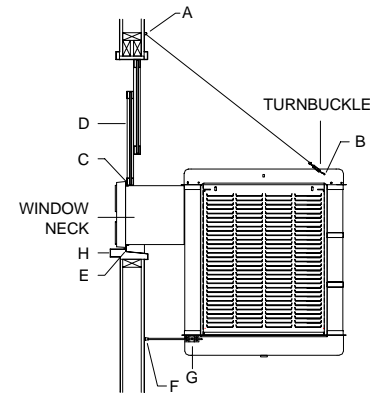

FIG. 1

- **Position cooler in window.** Position neck of cooler so that bottom of neck flange rests on window sill and flange (E-Fig. 1) is snug against edge of sill (H-Fig. 1). With cooler in position, hook the turnbuckles into the holes of the top panel near the back of the cooler (B-Fig. 1).

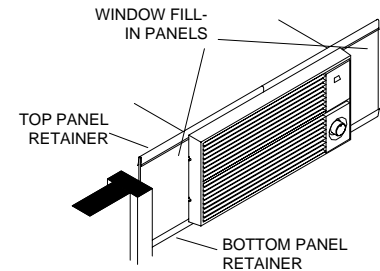

FIG. 2

- **Break fill-in panels to fit.** With cooler installed, as described above, measure for each window fill-in panel and score with sharp knife and straight edge guide to desired width. To break window fill-in panels, the panel should be laid over the edge of a straight flat surface at the point to be broken off. Apply pressure on the edge of the panel that extends over the edge of the surface and break off unwanted piece.
- **Install fill-in panels.** Place one window fill-in panel on each side of grill and into panel retainer strip at bottom of grill. Place the other panel retainer strips onto top of neck flange and fill-in panels. Be sure the panels are snug up against cooler neck.
- **Place window behind retainer strip.** Raise back of cooler so that the window (D-Fig. 1) may be brought down behind top of panel retainer strip (C-Fig. 1).
- **Level Cooler.** Adjust chains and turnbuckles so that cooler is level.
- **Adjust house legs.** Pull out house legs so that the rubber bumpers rest against house siding (F-Fig. 1). Tighten screw in retaining collar. (G-Fig. 1).

### CONNECTING WATER

- **Install overflow assembly.** Remove nut and place nipple through the hole in the pan, with the rubber washer between the pan and the head of the drain nipple (Fig. 3). Screw on nut and draw up tight against bottom of pan. Insert overflow pipe in nipple to retain water. Overflow pipe may be removed to drain pan when necessary. A garden hose may be screwed on the drain nipple to drain water away from your unit.

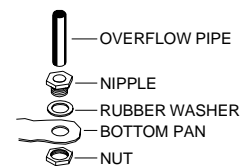

FIG. 3

- **Connect water supply line.** Install a sillcock and water valve on faucet as shown by figure 4. Place the nut and ferrule on the tubing and tighten the nut until water tight.

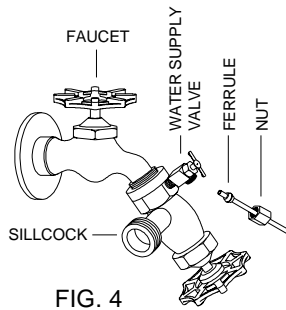

FIG. 4

- **Install float valve.** Install valve in the provided hole in corner post (Fig. 5) and attach water supply line.

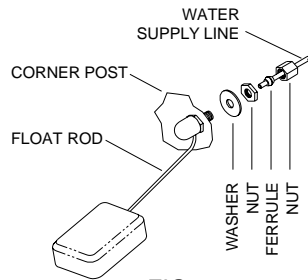

FIG. 5

- **Fill pan.** Allow water to fill to within 1" of top of pan and adjust float to maintain this water level. This can be accomplished by bending the float rod (Fig. 5).

- **Adjust water amount.** Your cooler is equipped with a unique water metering valve (Fig. 6). The amount of water delivered to the pads may be decreased by pressing the plastic valve as the arrows indicate. If water is splashing out of water troughs, you may need to decrease the amount of water delivery. Check to see that all pads are saturated with water and that there are no dry spots or openings in the pads.

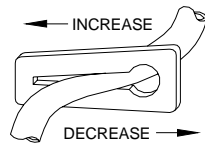

FIG. 6

## MAINTENANCE

**⚠ WARNING:** Before doing any maintenance be sure power is off and unit is unplugged. This is for your safety.

### SPRING START-UP

- **Clean pump.** Cleaning the pump is necessary once a year at start-up. For your safety, turn unit off and unplug from power receptacle. Remove the pump from the mount slot. Remove the base of the pump as shown in Fig. 7. Clean the pump and turn the impeller to ensure free operation. Remove the pump spout and check for any blockage. After cleaning, reinstall the base onto the pump. Reattach the pump to the mount in the cooler using the plastic retainer to ensure that the pump will not overturn. Do not forget to replace the spout and water delivery tube onto the pump outlet. The pump has automatic reset thermal protection.

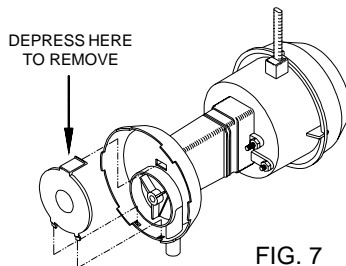

FIG. 7

- **Oil bearings.** The blower bearings, cooler motor and pump motor in this unit should be oiled with a few drops of non-detergent 20/30 weight oil once each year, unless these motors have no oil lines for oiling. Motors that have no lines are lifetime oiled at the factory and require no further oiling for the life of the unit.

**⚠ CAUTION:** Do not over oil. Over oiling can cause motor burn out, due to excessive oil getting into motor winding.

- **Check belt tension.** A 3 lb. force should deflect the belt 3/4 inches (see Fig. 8). Readjust belt if needed.

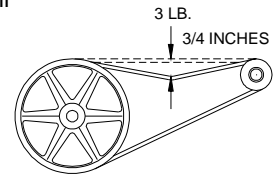

FIG. 8

- **Change Pads.** Aspen pads should be replaced once or twice a season, depending upon the length of the season. At the beginning and at mid season a clean pad is more absorbent and efficient and will deliver substantially more cool air.

### WINTER SHUT DOWN

- **Drain water.** Always drain all of the water out of the cooler and water supply line when not in use for prolonged periods, and particularly at the end of the season. Keep the water line disconnected from both the unit and water supply so that it does not freeze.

- **Cover unit.** To protect the life of the finish, a cover for the unit is suggested in extended periods of non use.

- **Unplug unit from power supply during extended periods of non-use.**

By following the operating, installation, and maintenance suggestions as outlined, you can get many years of efficient and satisfactory service from your cooler. In the event additional information is desired, your dealer will be more than glad to assist you in every possible way.

### WIRING DIAGRAM

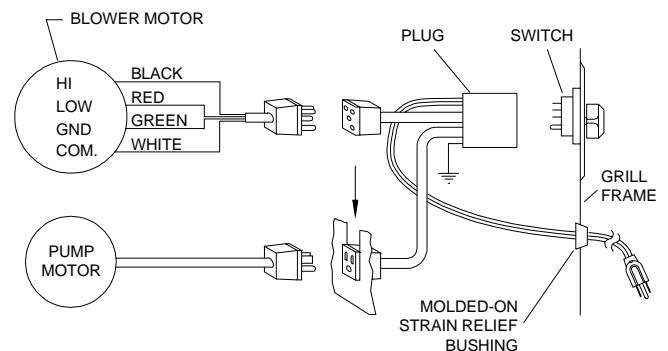

## TROUBLESHOOTING

<b><u>PROBLEM</u></b>	<b><u>POSSIBLE CAUSE</u></b>	<b><u>REMEDY</u></b>
Failure to start or no air delivery	<ol style="list-style-type: none"> <li>1. No electrical power to unit                             <ul style="list-style-type: none"> <li>• Fuse blown</li> <li>• Circuit breaker tripped</li> <li>• Electric cord unplugged or damaged</li> </ul> </li> <li>2. Belt too loose or tight</li> <li>3. Motor overheated                             <ul style="list-style-type: none"> <li>• Belt too tight</li> <li>• Blower bearings dry</li> </ul> </li> <li>4. Motor locked</li> </ol>	<ol style="list-style-type: none"> <li>1. Check power                             <ul style="list-style-type: none"> <li>• Replace fuse</li> <li>• Reset breaker</li> <li>• Plug in cords or replace if damaged</li> </ul> </li> <li>2. Adjust belt tension</li> <li>3. Determine cause of overheating                             <ul style="list-style-type: none"> <li>• Adjust belt tension</li> <li>• Oil blower bearings</li> </ul> </li> <li>4. Replace motor</li> </ol>
Inadequate air delivery with cooler running	<ol style="list-style-type: none"> <li>1. Insufficient air exhaust</li> <li>2. Belt too loose</li> <li>3. Pads plugged</li> </ol>	<ol style="list-style-type: none"> <li>1. Open windows or doors to increase air flow</li> <li>2. Adjust belt tension or replace if needed</li> <li>3. Replace pads</li> </ol>
Inadequate cooling	<ol style="list-style-type: none"> <li>1. Inadequate exhaust in house</li> <li>2. Pads not wet                             <ul style="list-style-type: none"> <li>• Pads plugged</li> <li>• Open spots in pads</li> <li>• Trough holes clogged</li> <li>• Pump not working properly</li> </ul> </li> </ol>	<ol style="list-style-type: none"> <li>1. Open windows or doors to increase air flow</li> <li>2. Check water distribution system                             <ul style="list-style-type: none"> <li>• Replace pads</li> <li>• Repack pads</li> <li>• Clean trough and unplug holes</li> <li>• Replace or clean pump (Unplug unit)</li> </ul> </li> </ol>
Motor cycles on and off	<ol style="list-style-type: none"> <li>1. Low voltage</li> <li>2. Excessive belt tension</li> <li>3. Blower shaft tight or locked</li> <li>4. Bearings dry</li> </ol>	<ol style="list-style-type: none"> <li>1. Check voltage</li> <li>2. Adjust belt tension</li> <li>3. Oil or replace bearings (Unplug unit)</li> <li>4. Oil bearings</li> </ol>
Noisy	<ol style="list-style-type: none"> <li>1. Bearings dry</li> <li>2. Wheel rubbing blower housing</li> <li>3. Loose parts</li> </ol>	<ol style="list-style-type: none"> <li>1. Oil bearings</li> <li>2. Inspect and realign (Unplug unit)</li> <li>3. Tighten loose parts</li> </ol>
Excessive humidity in house	<ol style="list-style-type: none"> <li>1. Inadequate exhaust</li> </ol>	<ol style="list-style-type: none"> <li>1. Open doors or windows</li> </ol>
Musty or unpleasant odor	<ol style="list-style-type: none"> <li>1. Stale or stagnate water in cooler</li> <li>2. Pads mildewed or clogged</li> <li>3. Pads not wetting properly                             <ul style="list-style-type: none"> <li>• Trough holes clogged</li> <li>• Pump not working properly</li> </ul> </li> </ol>	<ol style="list-style-type: none"> <li>1. Drain pan and clean pads</li> <li>2. Replace pads</li> <li>3. Check water distribution system                             <ul style="list-style-type: none"> <li>• Clean</li> <li>• Replace or clean pump (Unplug unit)</li> </ul> </li> </ol>
Water draining from cooler	<ol style="list-style-type: none"> <li>1. Float arm not adjusted properly</li> <li>2. Overflow assembly leaking</li> </ol>	<ol style="list-style-type: none"> <li>1. Adjust float</li> <li>2. Tighten nut and overflow pipe.</li> </ol>

## LIMITED WARRANTY

This warranty is extended to the original purchaser of an evaporative cooler installed and used under normal conditions. It does not cover damages incurred through accident, neglect, or abuse by the owner. We do not authorize any person or representative to assume for us any other or different liability in connection with this product.

### TERMS AND CONDITIONS OF WARRANTY

For Five Years from date of installation, we will replace the original base assembly if water leakage should occur due to rust out.

For One Year from date of installation, we will replace any original component provided by Champion Cooler Corporation which fails due to any defect in material or factory workmanship only.

### EXCLUSIONS FROM THE WARRANTY

We are not responsible for replacement of cooler pads. These are disposable components and should be replaced periodically. We are not responsible for any incidental or consequential damage resulting from any malfunction.

We are not responsible for any damage received from the use of water softeners, chemicals, descale material, plastic wrap, or if a motor of a higher horsepower than what is shown on the serial plate is used in the unit.

We are not responsible for the cost of service calls to diagnose cause of trouble, or labor charge to repair and/or the replacement of parts.

### HOW TO OBTAIN SERVICE UNDER THIS WARRANTY

Contact the Dealer where you purchased the evaporative cooler. If for any reason you are not satisfied with the response from the dealer, contact the Customer Service Department: Champion Cooler Corporation, 5800 Murray Street, Little Rock, Arkansas 72209. 1-800-643-8341.

THIS LIMITED WARRANTY APPLIES TO ORIGINAL PURCHASER ONLY

## GENERAL SPECIFICATIONS / ESPECIFICACIONES GENERALES

Model No. <i>Modelo</i>	Weight (lbs.) <i>Peso (libras)</i>		Cabinet Dimensions (in.) <i>Dimensiones De La Caja (pulgadas)</i>			Window Opening Req'd (in.) <i>Abertura Requerida (pulgadas)</i>	
	Dry <i>Seco</i>	Operating <i>Lleno</i>	Height <i>Altura</i>	Width <i>Anchura</i>	Depth <i>Profundidad</i>	Width <i>Anchura</i>	Height <i>Altura</i>
WC 33	152	229	33 7/16	28 1/8	28 1/8	25 3/8	12 7/8
WC 42	170	264	39 13/16	34 1/8	28 1/2	25 3/8	12 7/8
WC 47	175	269	39 13/16	34 1/8	28 1/2	25 3/8	12 7/8

## MOTOR SPECIFICATIONS / ESPECIFICACIONES DEL MOTOR

Model No. <i>Modelo</i>	Motor Part # <i>Motor - N°</i>	HP <i>HP</i>	Speed <i>Velocidad</i>	Volts <i>Voltios</i>	Motor Pulley Part # <i>Polea Del Motor - N°</i>	Electrical Cord Part # <i>Cable Eléctrico - N°</i>	Drive Belt Part # <i>Banda - N°</i>
WC 33	110442	1/3	2	115	110271	110364	110211 (4L-450)
WC 42	110442	1/3	2	115	110272	110364	110210 (4L-500)
WC 47	110443	1/2	2	115	110273	110364	110210 (4L-500)

## REPLACEMENT PARTS LIST / LISTA DE PIEZAS DE REPUESTO

All parts may be ordered from your dealer, but not directly from the factory. Be sure that you furnish the following information on all orders. /

Todas las partes pueden ser pedidas con su concesionario, pero no directamente a la fábrica. Incluya toda la información siguiente con su pedido:

1. Cooler serial number / Número de serie de la unidad
2. Description and part number / Descripción y número de parte
3. Cooler size / Tamaño de la unidad
4. Date of purchase / Fecha de compra

Failure to supply all of this information will delay your order. / El no proporcionar toda esta información resultará en una demora.

No. N°	Description / Descripción	WC 33	WC 42	WC47
1.	Top Pan / Tapa	222903-001	222905-001	222905-001
2.	Bottom Pan / Base De La Caja	222904-001	222903-004	222903-004
3.	Louvered Side / Reja Lateral	324006-101	324006-102	324006-102
4.	Louvered Back / Reja Posterior	324006-101	324007-101	324007-101
5.	Water Trough, Side / Canal De Agua, Lateral	226003-001	226003-001	226003-001
6.	Water Trough, Back / Canal De Agua, Posterior	226003-001	226003-002	226003-002
7.	Aspen Pads, Side / Filtros De Paja, Lateral	110091	110089	110089
8.	Aspen Pads, Back / Filtros De Paja, Posterior	110091	110090	110090
9.	Pad Retainer, Side / Soporte Para El Filtro, Lateral	3PW-4	3PW-4	3PW-4
10.	Pad Retainer, Back / Soporte Para El Filtro, Posterior	3PW-4	3PW-5	3PW-5
11.	Corner Post, With Float Hole / Poste De Esquina, Con Agujero Para Flotador	224003-002	224003-003	224003-003
12.	Corner Post, No Float Hole / Poste De Esquina, Sin Agujero Para Flotador	224003-002	224003-003	224003-003
13.	Front Panel / Panel De Frente	224104-001	224105-001	224105-001
14.	Tunnel / Túnel (Cuello Del Enfriador)	324104-003	324104-003	324104-003
15.	Blower Housing / Caja De La Rueda	324104-002	324105-002	324105-002
16.	Blower Wheel / Rueda	12BW	16BW	16BW
17.	Shaft, Blower Wheel / Eje De La Rueda	110162	110161	110161
18.	Bearings, Blower Wheel Shaft / Cojinetes Del Eje De La Rueda	110351	110351	110351
19.	Pulley, Blower Wheel / Polea De La Rueda	110274	110275	110275
20.	Drive Belt / Banda De Transmisión	110211	110210	110210
21.	Motor / Motor	110442*	110442*	110443*
22.	Pulley, Motor / Polea Del Motor	110271	110272	110273
23.	Electrical Cord, Motor / Cable Eléctrico Del Motor	110364	110364	110364
24.	Motor Mount / Montura Del Motor	314003-001	314003-005	314003-005
25.	Motor Mount Clips / Seguros Para Montar Motor	314005-001	314005-001	314005-001
26.	Float Valve / Válvula Del Flotador	FL-C	FL-C	FL-C
27.	Pump Mount / Montura De La Bomba	216003-001	216003-001	216003-001
28.	Pump Screen / Malla Para La Bomba	281001-001	281001-001	281001-001
29.	Pump Assembly / Bomba	C60P-120	C60P-120	C60P-120
30.	Pump Retainer / Sujetador De La Bomba	110866N	110866N	110866N
31.	Connector, Pump Mount / Unión Para La Montura De La Bomba	3PM-1	3PM-1	3PM-1
32.	Tube, Water Delivery / Tubo De Agua	310716	310716	310716
33.	Water Flow Control Valve / Válvula Reguladora Del Flujo De Agua	281013-001	281013-001	281013-001
34.	Water Distributor Assembly / Sistema Del Distribuidor De Agua	3D-2	3D-3	3D-3
35.	Holder, Water Distributor / Soporte Para El Distribuidor De Agua	110574	110574	110574
36.	Latch, Set / Bisagras	310803-001	310803-001	310803-001
37.	Over Flow Assembly / Montaje De Desagüe	3OA-1	3OA-1	3OA-1
38.	Grill Assembly / Rejilla Completa	310833-001	310833-001	310833-001
39.	Wiring Harness / Cableado Eléctrico	110371	110371	110371
40.	Switch / Interruptor	110425	110425	110425
41.	Knob, Switch / Perilla Del Interruptor	110836	110836	110836
42.	Grill Cover / Cubierta Para La Rejilla	110837	110837	110837
43.	House Leg Collar / Collar De La Pata	3HL-1	3HL-1	3HL-1
44.	House Leg / Pata	310811	310811	310811
45.	Retainers, Window Panels / Guarda De Retención Para Los Paneles	110599	110599	110599
46.	Window Panels / Paneles De Relleno Para La Ventana	281022-003	281022-003	281022-003

\* See motor specification table. / Vea la tabla de especificaciones del motor.

NOTE: Standard hardware items may be purchased from your local hardware store.

NOTA: Artículos de uso corriente pueden comprarse en la ferretería de su localidad.

# REPLACEMENT PARTS / PIEZAS DE REPUESTO

