

This Owner's Manual is provided and hosted by Appliance Factory Parts.



CUISINART SPB-7 Owner's Manual

[Shop genuine replacement parts for CUISINART SPB-7](#)

1. **Cover** Just press on. Tightfitting seal resists leakage.
2. **2-oz. Measured Pour Lid** Allows you to measure and add ingredients without removing the cover.
3. **40-oz. Glass Jar with Dripless Pour Spout** Has a unique, sturdy, wide-mouth design and a dripless pour spout for mess-free pouring.
4. **Leak-proof Rubber Gasket (not shown)** Holds the glass jar snugly in position for safe operation.
5. **High-quality Cutting Assembly with Patented Stainless Steel Blades** Is strong enough for all blender tasks, including tough jobs, from ice crushing to chopping delicate herbs.
6. **Collar (Locking Ring)** Is self-aligning so that the glass blender jar slides easily into position, eliminating the frustration of twisting and turning the blender jar to lock into place.
7. **Heavy-duty Motor Base** Is so sturdy and stable, it will not "walk" on your counter—even during ice crushing!
8. **7-Speed Touchpad Control with Indicator Lights** Is easy to use, read and clean. The red LED lights clearly indicate what blender speed you are using.
- 8a. **Pulse at Any Speed Button** Allows you to pulse at any speed from high to low, so you can blend ingredients only as much as needed.
- 8b. **Ice Crush Button** This button is preset to the best speed for crushed ice.
9. **Slip-proof Feet** Prevent movement during use and prevent damaging marks on countertops or tables.
10. **Cord Storage (not shown)** Keeps countertop safe and neat by conveniently storing excess cord.

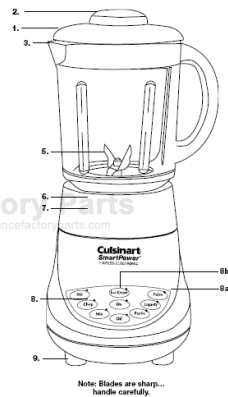

[Find Your CUISINART Small Appliance Parts - Select From 213 Models](#)

----- Manual continues below -----

Cuisinart®

INSTRUCTION AND
RECIPE BOOKLET



SmartPower® 7-Speed Electronic Blender

SPB-7 Series

For your safety and continued enjoyment of this product, always read the instruction book carefully before using.

IMPORTANT SAFEGUARDS

When using an electrical appliance, basic safety precautions should always be followed, including the following:

1. **READ ALL INSTRUCTIONS BEFORE USING.**
2. To protect against the risk of electrical shock, do not put motor base of blender in water or other liquid.
3. This appliance should not be used by or near children or individuals with certain disabilities.
4. Unplug from outlet when not in use, before putting on or taking off parts, and before cleaning or removing contents from blender jar. **Never put hands into the blender jar or container, or handle the blades with appliance plugged in.**
5. Avoid contact with moving parts.
6. Do not operate any appliance with a damaged cord or plug or after the appliance malfunctions, or is dropped or damaged in any manner. Return appliance to nearest Cuisinart® service facility for examination, repair, and/or mechanical or electrical adjustment.
7. The use of attachments, including canning or ordinary jars, not recommended or sold by Cuisinart may cause fire, electrical shock, or risk of injury to persons.
8. Do not use outdoors.
9. Do not let cord hang over edge of counter or table or touch hot surfaces.
10. **Keep hands and utensils out of jar while blending, to reduce the risk of severe injury to persons or damage to blender itself.** A rubber or plastic spatula may be used but must be used only when the blender is turned off.
11. When blender is in ON mode, and LED lights are flashing or glowing, do not touch cutting assembly, interfere with blade movement, or remove blender jar cover. Accidentally touching a speed button may activate the blender.
12. **BLADES ARE SHARP. HANDLE CAREFULLY.**
13. To reduce the risk of injury, never place cutting assembly on base unless the blender jar is properly attached.
14. Always operate blender with the cover in place.
15. Never leave your blender unattended while running.
16. When blending HOT liquids, remove measured pour lid (center piece of cover) to allow steam to escape.
17. Twist on locking ring firmly. Injury can result if moving blades accidentally become exposed.
18. Do not use an extension cord with this unit. Doing so may result in fire, electrical shock, or personal injury.
Regarding your cord set: A longer cord has been provided so that you will have flexibility in positioning your Cuisinart® SmartPower® Blender near an electrical outlet. Exercise care when using the longer cord, to avoid entangling or tripping over the cord. The longer cord should be arranged so that it will not drape over the counter or tabletop, where it can be pulled on by children or tripped over. Excess cord should be stored in the cord storage area at the back of the blender base to avoid injury caused by the longer cord.
19. Wash the blender jar, cutting assembly, locking ring, and cover before first use.
20. **WARNING: TO REDUCE THE RISK OF ELECTRICAL SHOCK OR FIRE, DO NOT REMOVE THE BASE PANEL. NO USER SERVICEABLE PARTS ARE INSIDE. REPAIR SHOULD BE DONE ONLY BY AUTHORIZED PERSONNEL.**
21. **WARNING: FLASHING LIGHT INDICATES BLENDER IS READY TO OPERATE. DO NOT TOUCH BLADES.**

**SAVE THESE INSTRUCTIONS
FOR HOUSEHOLD USE ONLY**

NOTICE

This appliance has a polarized plug (one prong is wider than the other).

To reduce the risk of electric shock, this plug will fit into a polarized outlet only one way. If the plug does not fit fully into the outlet, reverse the plug.

If it still does not fit, contact a qualified electrician. Do not modify the plug in any way.

Maximum rating of 500 watts is based on the jar attachment that draws the greatest power. Other recommended attachments may draw significantly less power.

This unit comes with a resettable thermal fuse to prevent damage to the motor in the case of extreme overload. Simply unplug the unit, rest it for 15 minutes and continue.

UNPACKING INSTRUCTIONS

1. Place the gift box containing your Cuisinart® SmartPower® 7-Speed Electronic Blender on a flat, sturdy surface before unpacking.
2. Remove instruction booklet and other printed materials from top of corrugated insert. Next remove the top corrugated insert.
3. Carefully lift blender base from box and set aside.
4. Remove the lower corrugated insert containing the blender jar assembly. Be careful not to tip the jar when removing.
5. Remove any additional literature from the box.

To assemble the blender, follow the Assembly instructions on page 5 of this instruction booklet. Replace all corrugated inserts in the box and save the box for repackaging.

Before using for the first time: Wash all parts according to the Cleaning and Maintenance section on page 7 of this booklet to remove any dust or residue.

CONTENTS

Important Safeguards	2
Unpacking Instructions	3
Introduction	3
Features and Benefits	4
Use and Care/Assembly	5
Helpful Reminders	5
Operation	5
Easy Reference Guides	6
Cleaning and Maintenance	7
Do's and Don'ts	8
Recipe Tips	9
Recipes	10
Warranty Information	22

INTRODUCTION

The life of the party, the SmartPower® 7-Speed Electronic Blender is engineered with seven speeds, including one speed just for ice crushing. The results are delicious, professional-quality frozen drinks. The SmartPower® 7-Speed Electronic Blender purées, blends, mixes, stirs, liquefies, and more. No need to worry about spills or messy cleanups, either. The SmartPower® 7-Speed Electronic Blender comes with a dripless pour spout and touchpad that wipes clean in an instant. Like all Cuisinart® appliances, the SmartPower® 7-Speed Electronic Blender was designed to bring you years of enjoyment, and it is backed by a three-year limited warranty.

FEATURES AND BENEFITS

- 1. Cover** Just press on. Tightfitting seal resists leakage.
- 2. 2-oz. Measured Pour Lid** Allows you to measure and add ingredients without removing the cover.
- 3. 40-oz. Glass Jar with Dripless Pour Spout**
Has a unique, sturdy, widemouth design and a dripless pour spout for no-mess pouring.
- 4. Leak-proof Rubber Gasket (not shown)** Holds the glass jar snugly in position for safe operation.
- 5. High-quality Cutting Assembly with Patented Stainless Steel Blades**
Is strong enough for all blender tasks, including tough jobs, from ice crushing to chopping delicate herbs.
- 6. Collar (Locking Ring)**
Is self-aligning so that the glass blender jar slides easily into position, eliminating the frustration of twisting and turning the blender jar to lock into place.
- 7. Heavy-duty Motor Base**
Is so sturdy and stable, it will not “walk” on your counter – even during ice crushing!
- 8. 7-Speed Touchpad Control with Indicator Lights**
Is easy to use, read and clean. The red LED lights clearly indicate what blender speed you are using.
- 8a. Pulse at Any Speed Button**
Allows you to pulse at any speed from high to low, so you can blend ingredients only as much as needed.
- 8b. Ice Crush Button**
This button is preset to the best speed for crushed ice.
- 9. Slip-proof Feet**
Prevent movement during use and prevent damaging marks on countertops or tables.
- 10. Cord Storage (not shown)**
Keeps countertop safe and neat by conveniently storing excess cord.

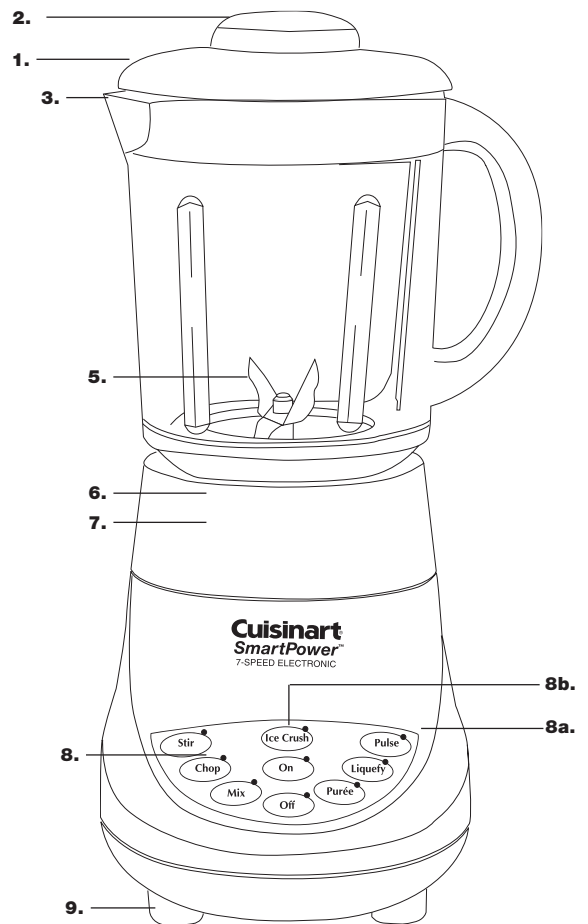

**Note: Blades are sharp...
handle carefully.**

USE AND CARE

ASSEMBLY

To use your Cuisinart® SmartPower® Electronic Blender, begin by assembling the blender jar. See diagram, next page.

1. Turn the blender jar (a) upside down, and place it flat on a sturdy surface.
2. Position the rubber gasket (b) on the round opening on the bottom of the blender jar.
3. Turn the cutting assembly (c) upside down, and place the blade end in the blender jar opening. **Note: Blades are sharp. Handle carefully.**
4. Secure the rubber gasket and cutting assembly into position by placing the smaller opening of the locking ring (d) on top of the cutting assembly. Engage threads by twisting the locking ring clockwise until tightened. Make sure locking ring is tightly fastened to blender jar. Once assembled, turn the blender jar right-side up.
5. Push the cover onto the top of the blender jar. Insert the measured pour lid into the cover, aligning the tabs in the pour lid with the slots in the cover. Twist clockwise to lock pour lid into the cover.
6. Place the blender jar on the motor base so that the jar markings are facing you and the handle is positioned to one side.
7. Plug in power cord. Your blender is now ready to be used.

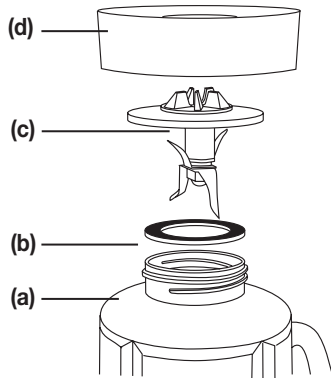

HELPFUL REMINDERS

- Once the cover is in position, additional ingredients can be added during blending: twist the measured pour lid counterclockwise until the tabs in the pour lid align with the slots in the cover; pull up pour lid, add ingredients, and replace the measured pour lid.
- Cover should always be in place while the unit is on.
- **Warning:** Do not place blender jar on base while motor is running.
- Do not twist locking ring from blender jar when removing blender jar from base. Simply lift blender jar from motor base.
- Boiling liquid or solid frozen foods (with the exception of ice cubes or ½-inch [1.3 cm] pieces of frozen fruit) should never be placed in the blender jar.
- Do not place ice, frozen foods or very cold liquids in a blender jar that has come directly from a hot dishwasher.
- Do not place very hot liquids or foods in a blender jar that has come directly from the freezer. Boiling liquids should cool for 5 minutes before being placed in blender jar.
- Follow Cleaning and Maintenance instructions on page 7, prior to your first use.

OPERATION

1. Place the motor base of your Cuisinart® SmartPower® Electronic Blender on a flat, sturdy surface. It is important that the surface be clean and dry. Assemble the blender by following the assembly instructions. Once the jar is assembled and is in position on the motor base, plug the Cuisinart® SmartPower® Electronic Blender into an electrical outlet.

- Add all necessary ingredients to the blender jar, and replace the cover. You may add more ingredients by lifting the measured pour lid and dropping ingredients through the fill area. Replace the measured pour lid after adding ingredients. **Do not place hands in blender jar with blender plugged in.**

Note: Add liquid ingredients first, then follow with solid ingredients. This will provide more consistent blending and prevent unnecessary stress on the motor.

Note: To remove blender jar cover, lift edge of cover upward. Lifting measured pour lid will not remove cover.

- To start blending:** Press the On button. The red On LED light will flash, indicating that the blender is turned on but no speed has been selected.
- Press the desired blending speed:** Both the On indicator light and the activated speed indicator light will glow. The blender will now be functioning at the desired speed. It is possible to switch speeds without pressing the Off button, by simply pushing the next desired speed button.

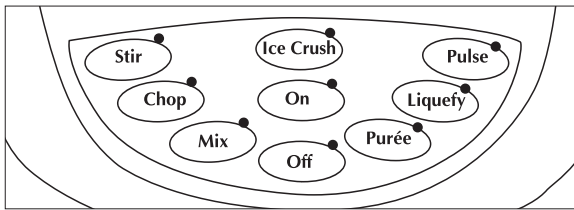

- To stop the blending process:** Re-press the activated speed button. The blending process will stop. The red On indicator light will continue to flash to let you know that the blender is still on. The blender can be completely deactivated and stopped at any speed by pushing the Off button. You will need to press the On button again to continue blending.
- To reset the blender:** The unit has an advanced thermal resettable fuse feature. If the event of an overload condition the unit will shut down to protect the motor from overheating. When this happens, to reset the unit, unplug the blender and let it cool down for a minimum of 15 minutes. Then look to reduce the contents and/or clear any jams, then restart as noted in the operating directions.

QUICK REFERENCE GUIDE

To activate blender	Press On – The blender is in On mode.
To begin blending	Press desired speed button.
To change speeds	Press desired speed button.
To pulse	In On mode press Pulse, then press and release desired speed button as needed.
To crush ice	In On mode, press and release Ice Crush button as needed.
To stop blending (and deactivate blender)	Press Off button.
To stop blending (in Pulse or Ice Crush mode)	Release button.
To stop blending in Stir, Chop, Mix, Purée, or Liquefy mode	Press speed button again. This will return the blender to On mode. Press Off button to turn blender off.

SPEED SELECTION GUIDE

Refer to this guide to choose the best speed for your desired result.

Ingredient/Recipe	Speed	Result
Reconstituting frozen orange juice concentrate	Stir	Smooth and full-bodied
Mayonnaise	Stir	Thick and creamy
Salad dressings	Stir	Desired consistency
Nuts	Chop	Coarse to fine
Whipping cream	Mix	Thick topping
Bread crumbs	Mix	Uniformly fine
Grating citrus zest	Purée	Uniformly fine
Milk shakes	Purée	Smooth and creamy
Baby food	Purée	Smooth and creamy
Health drinks	Liquefy	Smooth and creamy
Frozen cocktails	Liquefy	Thick and slushy
Grinding hard cheese	Liquefy	Coarse to fine
Spices	Liquefy	Coarse to fine
Ice	Ice Crush	Snowy

-
7. **Pulse mode:** While the blender is turned on, you can create a burst of power for quick, efficient blending by activating the Pulse function. To do so, first push the Pulse button, which will cause the pulse indicator light to flash. Next, push and release the desired speed button. Repeat as desired. You determine the duration of each pulse. While pulsing, all indicator lights (the On, the Pulse, and the desired speed) will glow. The Pulse function can be used to break apart larger pieces of food or to control the texture of food when chopping. The Pulse function is also effective in starting the blending process when you do not want continuous power, or when processing items that do not require an extended amount of blending.
 8. **To crush ice:** The SmartPower® Electronic Blender motor is strong enough to crush ice without liquid at any speed; however, for your convenience, we have preset the best speed for ice crushing. To give you greater control, the Ice Crush function automatically operates as a Pulse function. To crush ice, place ice cubes in the blender jar, and place the cover and the measured pour lid on the blender jar. Press the On button. Press the Ice Crush button in short pulses until ice is crushed to desired consistency. See the Recipe Tips section on page 9 for details
 9. **To dislodge food:** Use a rubber or plastic spatula to help remove food lodged around the cutting assembly. **DO NOT USE SPATULA UNTIL YOU HAVE TURNED THE BLENDER OFF.** Replace the cover and measured pour lid and continue blending, if necessary. Make sure spatula is not inside the blender jar before blending.
 10. **When finished blending:** Press the Off button and unplug the blender from the electrical outlet. Never remove the blender jar from the motor base until the blender is off. Do not twist locking ring from blender jar when removing jar from motor base. Simply lift blender jar from motor base. **Do not place hands in blender jar with blender plugged in.**

CLEANING AND MAINTENANCE

Always unplug your Cuisinart® SmartPower® Electronic Blender from the electrical outlet before cleaning. The blender is made of corrosion-resistant parts that are easy to clean. Before first use and after every use, clean each part thoroughly. Periodically check all parts before reassembly. If any part is damaged or blender jar is chipped or cracked, **DO NOT USE BLENDER.**

Remove the blender jar from the motor base by lifting straight up and away. Twist off the locking ring by turning counterclockwise.

Remove the cutting assembly and rubber gasket. Wash in warm soapy water, rinse, and dry thoroughly.

Place the locking ring in the upper rack of the dishwasher or wash in warm water.

CAUTION: Handle the cutting assembly carefully. It is SHARP and may cause injury. Do not attempt to remove blades from cutting assembly.

Remove the blender jar cover and the measured pour lid. Wash in warm, soapy water; rinse and dry thoroughly, or place in upper rack of dishwasher. The blender jar must be washed in warm soapy water and rinsed and dried thoroughly. The blender jar can also be placed upside down in dishwasher.

Finally, wipe the motor base clean with a damp cloth to remove any residue, and dry thoroughly. Never submerge the motor base in water or other liquid, or place in a dishwasher.

Tip: You may wish to clean your blender cutting assembly as follows: Squirt a small amount of dishwashing liquid into assembled blender jar and fill halfway with warm water. Run on Stir for 15 seconds. Repeat, using clean tap water. Empty blender jar and carefully disassemble parts. Wash cutting assembly, gasket and locking ring in warm, soapy water. Rinse and dry all parts thoroughly.

DO's and DON'Ts WHEN USING YOUR BLENDER

Do:

- Make sure the electrical outlet is rated at the same voltage as that stated on the bottom of the blender motor base.
- Always use the blender on a clean, sturdy and dry surface.
- **Always add liquid ingredients to the blender jar first, then add remaining ingredients. This will ensure that ingredients are uniformly mixed.**
- Cut most foods into cubes approximately ½ inch (1.3 cm) to 1 inch (2.5 cm) to achieve a more uniform result. Cut all cheeses into pieces no larger than ½ inch (1.3 cm).
- Use the measured pour lid to measure liquid ingredients such as alcohol. Replace measured pour lid after ingredients have been added.
- Use a rubber or plastic spatula as needed, only when the blender is turned off. Never use metal utensils, as damage may occur to the blender jar or cutting assembly.
- Place cover on firmly. Always operate the blender with the cover on.
- Make sure locking ring is tightly attached to blender jar.
- Always remove locking ring, cutting assembly, and rubber gasket before cleaning.

- When scraping the blender jar with a spatula, remove the food from the sides of the blender jar and place food in the center of the blender jar, over the cutting assembly.
- When chopping fresh herbs, garlic, onion, zest, bread crumbs, nuts, spices, etc., make sure the blender jar and cutting assembly are completely dry.
- If food tends to stick to the sides of the blender jar when blending, pulse in short bursts.
- Pulses should be short bursts. Space the pulses so the blades stop rotating between pulses.

Don't:

- Don't store food or liquids in your blender jar.
- Don't place cutting assembly and locking ring onto motor base without the blender jar attached.
- Blender will not mash potatoes, knead heavy dough, or beat egg whites.
- Don't remove blender jar while unit is on. Keep the blender jar cover on the blender jar while blending.
- Don't twist locking ring from blender jar when removing blender jar from motor base. Simply lift blender jar from motor base.
- Don't overprocess foods. Blender will achieve most desired results in seconds, not minutes.
- Don't overload blender. If the motor stalls, turn the blender off immediately, unplug the unit, and remove a portion of the food, then continue.
- Don't use any utensil inside the blender jar while the motor is on.
- Don't use any container or accessories not recommended by Cuisinart. Doing so may result in injury.
- Don't place hands inside the blender jar when blender is plugged in.
- Don't add boiling liquids or frozen foods (except ice cubes or ½-inch pieces of frozen fruit) to glass blender jar. Boiling liquids should cool for 5 minutes before being placed in blender jar.

RECIPE TIPS

The simple recipes that follow include some old Cuisinart® favorites, as well as some creative combinations that are sure to please your friends and family. Thanks to the superior ice crushing power of the SmartPower® Electronic Blender, you'll also be able to make delicious frozen drinks.

- **Chopping Nuts:** Pulse ½ cup of nuts (shells removed) on Chop 4 to 5 times. Turn blender off; scrape blender jar with spatula. Turn blender on and pulse on Chop 2 to 3 times. Turn blender off. Pulse fewer times for more coarsely chopped results. For best results, process no more than 1 cup at a time.
- **Bread, Cookie or Cracker Crumbs:** For best results, use day-old bread (drier bread works best). Break bread slices into ½-inch pieces, and process no more than 1 cup of pieces at a time on Mix for 5 to 10 seconds. Crackers and cookies should also be broken into ½-inch pieces; process 1 cup at a time on Mix for 10 to 15 seconds. Turn blender off.
- **Crushing Ice:** Add up to 10 large ice cubes to blender jar. Press the Ice Crush button, using short bursts, 10 times, or until cubes are the consistency of snow. Turn blender off. Pulse fewer times if coarsely chopped ice is desired.
- **Grating Citrus Zest:** For best results, blender jar and cutting assembly must be clean and dry. Remove zest from fruit in strips (using vegetable peeler). Use no more than 8 strips at a time (zest of one medium lemon). Cut strips in half. Add strips and 1 teaspoon sugar (from recipe) to the blender jar. Blend on Liquefy for 15 to 20 seconds. Turn blender off.
- **Baby Food:** Combine ½ cup cooked vegetables, fruit or meat with 3 tablespoons liquid (water, milk or fruit juice) in the blender jar. Blend on Purée for 15 to 20 seconds. Add more liquid if necessary and process again. Turn blender off.
- **Grinding Hard Cheese:** Cut cheese into ½-inch pieces. Blend on Liquefy for 30 seconds. Turn blender off. For best results, grind no more than 3 ounces of cheese at a time.
- **Grinding Spices:** For best results, blender jar and cutting assembly must be clean and dry. Add ¼ to ½ cup of spices/seeds/peppercorns to blender jar. Blend on Liquefy for 30 to 35 seconds. Turn blender off.
- **Whipping Cream:** Whip 1 cup of cream (whipping or heavy cream) at a time. Blend on Mix, and process for 45 to 60 seconds or until creamy and smooth. If making sweetened cream, add sugar after 10 seconds. Turn blender off. Makes about 1 cup.
- **Puréeing Sun-Dried Tomatoes:** Rehydrate 1 ounce of tomatoes in 1 cup boiling water. Allow to sit for 10 minutes or until softened. Add tomatoes and water to blender jar. Cover and pulse on Liquefy 5 times; then run continuously on Liquefy for 15 to 20 seconds. Turn blender off. Drain in fine strainer if desired. Makes about ½ cup of puréed tomatoes.

RECIPES

FROZEN BEVERAGES

FROZEN CRANBERRY-ORANGE MIMOSA

Makes ten 5½-ounce servings

- 1 cup cranberry juice cocktail, chilled**
- 1 cup orange juice, chilled**
- 1½ cups ice cubes**
- 1 bottle (750 ml) brut champagne, chilled**

Place cranberry juice, orange juice, and ice cubes in the Cuisinart® SmartPower® blender jar in order listed. Place cover on jar. Turn blender on and process on Liquefy until thick and frothy, about 30 to 40 seconds. Turn blender off. Pour ⅓ cup juice mixture into each champagne glass. Top with chilled champagne. Serve immediately.

Nutritional information per serving:
Calories 32 (0% from fat) • carb. 8g • pro. 0g • fat 0g • sat. fat 0g
• chol. 0mg • sod. 14mg • calc. 3mg • fiber 1g

FROZEN FRUIT DAIQUIRI

Makes five 4-ounce servings

- 4 ounces frozen limeade concentrate, thawed**
- 3 ounces light rum**
- 2 cups ice cubes**
- 1 cup ripe fruit, cut into 1-inch pieces (strawberries, bananas, peaches)**

Place ingredients in the Cuisinart® SmartPower® blender jar in order listed. Place cover on blender jar. Turn blender on and process on Liquefy until slushy, about 45 to 50 seconds. Turn blender off. Serve immediately.

Nutritional information per serving:
Calories 90 (0% from fat) • carb. 13g • pro. 0g • fat 0g • sat. fat 0g
• chol. 0mg • sod. 3mg • calc. 5mg • fiber 1g

FROZEN DAIQUIRI

Makes four 4-ounce servings

- 4 ounces frozen limeade concentrate, thawed**
- 3 ounces light rum**
- 2 cups ice cubes**

Place ingredients in the Cuisinart® SmartPower® blender jar in order listed. Place cover on blender jar. Turn blender on and process on Liquefy until slushy, about 45 to 50 seconds. Turn blender off. Serve immediately.

Nutritional information per serving:
Calories 105 (0% from fat) • carb. 14g • pro. 0g • fat 0g • sat. fat 0g
• chol. 0mg • sod. 4mg • calc. 0mg • fiber 0g

RUM AND ORANGE FREEZE

Makes four 4-ounce servings

- 1 cup orange juice**
- 1½ ounces dark rum**
- 1 cup ice cubes**

Place ingredients in the Cuisinart® SmartPower® blender jar in order listed. Place cover on jar. Turn blender on and process on Liquefy until slushy, about 30 seconds. Turn blender off. Serve immediately.

Nutritional information per serving:
Calories 45 (0% from fat) • carb. 6g • pro. 0g • fat 0g • sat. fat 0g
• chol. 0mg • sod. 2mg • calc. 6mg • fiber 0g

MARGARITA

Makes four 4-ounce servings

- ½ cup lime juice**
- 4 ounces tequila**
- 1 tablespoon granulated sugar**
- 2 cups ice cubes**

Place ingredients in the Cuisinart® SmartPower® blender jar in order listed. Place cover on jar. Turn blender on and process on Liquefy until slushy, about 45 to 60 seconds. Turn blender off.

Serve immediately.

Nutritional information per serving:
Calories 94 (0% from fat) • carb. 6g • pro. 0g • fat 0g • sat. fat 0g
• chol. 0mg • sod. 4mg • calc. 4mg • fiber 0g

PIÑA COLADA

Makes two 6-ounce servings

- ½ cup unsweetened pineapple juice**
- 2 ounces sweetened cream of coconut**
- 2 ounces dark rum**
- 1 cup ice cubes**

Place ingredients in the Cuisinart® SmartPower® blender jar in order listed. Place cover on jar. Turn blender on and process on Liquefy until slushy, about 45 to 50 seconds. Turn blender off. Serve immediately.

Nutritional information per serving:
Calories 143 (25% from fat) • carb. 10g • pro. 1g • fat 4g • sat. fat 2g
• chol. 11mg • sod. 17mg • calc. 14mg • fiber 1g

MILK SHAKES/FRAPPEES

ORANGE CREAMSICLE

Makes one 12-ounce serving

- ¾ cup fat-free milk**
- 2 scoops (8 ounces) orange sherbet**
- 2 tablespoons instant fat-free dry milk**
- ½ teaspoon pure vanilla extract**

Place ingredients in the Cuisinart® SmartPower® blender jar in order listed. Place cover on jar. Turn blender on and process on Liquefy until smooth, about 30 seconds. Turn blender off. Serve immediately.

Nutritional information per serving:
Calories 396 (9% from fat) • carb. 76g • pro. 14g • fat 4g • sat. fat 3g
• chol. 20mg • sod. 265mg • calc. 411mg • fiber 5g

CHOCOLATE MILK SHAKE

Makes two 8-ounce servings

- 1 cup reduced-fat milk**
- 1 scoop (4 ounces) vanilla ice cream**
- 2 tablespoons chocolate syrup**

Place ingredients in the Cuisinart® SmartPower® blender jar in order listed. Place cover on jar. Turn blender on and process on Purée until smooth and creamy, about 25 to 30 seconds. Serve immediately.

Nutritional information per serving:
Calories 243 (41% from fat) • carb. 29g • pro. 7g • fat 11g • sat. fat 7g
• chol. 34mg • sod. 127mg • calc. 234mg • fiber 1g

Variation: For a strawberry milk shake, substitute strawberry syrup and strawberry ice cream.

CAPPUCCINO SHAKE

Makes four 8-ounce servings

- 1 cup espresso coffee or strong coffee**
- ½ cup half-and-half**
- ¼ cup granulated sugar***
- 1 cup ice cubes**
- ground cinnamon**

Place all ingredients except cinnamon in the Cuisinart® SmartPower® blender jar in order listed. Place cover on jar. Turn blender on and process on Liquefy until smooth, about 25 to 30 seconds. Pour into glasses, and sprinkle with cinnamon. Serve immediately.

*Use less sugar (about 3 tablespoons) if a less sweet beverage is desired.

Nutritional information per serving:
Calories 87 (31% from fat) • carb. 14g • pro. 1g • fat 3g • sat. fat 2g
• chol. 11mg • sod. 14mg • calc. 33mg • fiber 0g

Variation: Pour mixture into ice cube trays, and freeze until solid. Place in blender jar, and crush, using Ice Crush to make a refreshing frozen dessert.

ICE CREAM SODA

Makes two 12-ounce servings

- 1 cup reduced-fat milk**
- 1 scoop (4 ounces) vanilla ice cream**
- 2 tablespoons chocolate syrup**
- 1 cup ginger ale**

Place milk, ice cream, and chocolate syrup in blender jar in order listed. Place cover on blender jar. Turn blender on and process on Purée until smooth and creamy, about 40 to 45 seconds. Turn blender off. Divide ginger ale into two tall glasses (about 14 to 16 ounces each). Add ice cream mixture, and stir gently. Serve immediately.

Nutritional information per serving:

*Calories 287 (34% from fat) • carb. 40g • pro. 7g • fat 11g • sat. fat 7g
• chol. 34mg • sod. 136mg • calc. 238mg • fiber 1g*

MOCHA SHAKE

Makes one 12-ounce serving

- 1 teaspoon instant coffee crystals**
- 1 tablespoon hot water**
- ½ cup reduced-fat milk**
- 2 scoops (8 ounces) vanilla low-fat frozen yogurt or vanilla ice milk**
- 2 tablespoons chocolate syrup**

Dissolve coffee crystals in hot water, and place in the Cuisinart® SmartPower® blender jar. Add remaining ingredients in order listed. Place cover on jar. Turn blender on and process on Purée until smooth, about 25 to 30 seconds. Turn blender off. Serve immediately.

Nutritional information per serving:

*Calories 479 (28% from fat) • carb. 71g • pro. 15g • fat 15g • sat. fat 7g
• chol. 43mg • sod. 255mg • calc. 540mg • fiber 1g*

SMOOTHIES

ALL-FRUIT SMOOTHIE

Makes six 6-ounce servings

- ⅓ cup orange juice**
- 1 cup cantaloupe, cut into 1-inch pieces**
- 1 cup raspberries**
- 1 cup canned pineapple chunks, drained**
- 1 cup navel orange segments, cut into 1-inch pieces**
- 1 cup strawberries, cut into 1-inch pieces**
- 1 medium banana, cut into 1-inch pieces**
- 1 cup ice cubes**

Layer the ingredients in the Cuisinart® SmartPower® blender jar in the order listed. Do not pack fruit tightly into blender jar. Place cover on jar. Turn blender on and process on Liquefy until smooth, about 30 to 40 seconds. Turn blender off. Serve immediately.

NOTE: The riper the fruit, the sweeter the smoothie.

Nutritional information per serving:

*Calories 92 (0% from fat) • carb. 22g • pro. 1g • fat 0g • sat. fat 0g
• chol. 0mg • sod. 5mg • calc. 30mg • fiber 4g*

BANANA-PINEAPPLE FREEZE

Makes two 8-ounce servings

- 1 cup unsweetened pineapple juice**
- ½ medium banana, cut into 1-inch pieces**
- ¼ cup instant fat-free dry milk**
- 1 cup ice cubes**

Place ingredients in the Cuisinart® SmartPower® blender jar in order listed. Place cover on jar. Turn blender on and process on Liquefy until smooth, about 25 to 30 seconds. Turn blender off. Serve immediately.

Nutritional information per serving:

*Calories 152 (0% from fat) • carb. 32g • pro. 6g • fat 0g • sat. fat 0g
• chol. 3mg • sod. 87mg • calc. 124mg • fiber 2g*

DIPS/SPREADS/APPETIZERS

For best results when blending fresh herbs, the herbs, blender jar and cutting assembly must be dry and clean.

HUMMUS

Makes 2¼ cups

- ½ cup fresh lemon juice
- 2 cups canned, garbanzo beans (chickpeas), drained
- 2 tablespoons water
- 4 medium garlic cloves, peeled, quartered
- 4 tablespoons tahini (optional)
- 1½ tablespoons olive oil
- 2 teaspoons table salt
- 1 teaspoon chopped parsley

Place lemon juice, garbanzo beans, water, garlic, tahini, olive oil and salt in the Cuisinart® SmartPower® blender jar in order listed. Place cover on jar. Turn blender on and process on Liquefy until smooth, about 20 seconds. Turn blender off. Scrape blender jar with a spatula. Turn blender on and process an additional 25 to 30 seconds until smooth. Turn blender off. Transfer to a serving dish, and sprinkle with parsley. Serve at room temperature.

Nutritional information per tablespoon:

*Calories 40 (27% from fat) • carb. 6g • pro. 1g • fat 1g • sat. fat 0g
• chol. 0mg • sod. 69mg • calc. 12mg • fiber 1g*

MINTED YOGURT SAUCE

Makes two cups

- 2 cups lowfat vanilla yogurt
- 1 tablespoon granulated sugar
- 3 tablespoons fresh mint leaves

Place ingredients in the Cuisinart® SmartPower® blender jar. Place cover on blender jar. Turn blender on and process on Purée until well blended, about 10 to 15 seconds. Turn blender off. Serve chilled with fresh fruit.

Nutritional information per tablespoon:

*Calories 16 (0% from fat) • carb. 3g • pro. 1g • fat 0g • sat. fat 0g
• chol. 1mg • sod. 8mg • calc. 27mg • fiber 0mg*

Variation: Substitute fruit-flavored yogurt.

MEXICAN SALSA CRUDA

Makes two cups

- 1 can (28 ounces) plum tomatoes, drained
- ¼ cup fresh cilantro leaves
- 2 jalapeño peppers, halved, seeded, cut into ½-inch pieces
- 1 small onion, peeled, cut into ½-inch pieces
- 1 teaspoon fresh lime juice
- 1 teaspoon table salt

Place ingredients in the Cuisinart® SmartPower® blender jar in order listed. Place cover on blender jar. Turn blender on and Pulse on Mix 5 to 6 times until coarsely chopped. Turn blender off. Allow to sit for 1 to 2 hours to develop flavor. Drain before serving if a thicker salsa is desired.

Nutritional information per tablespoon:

*Calories 8 (0% from fat) • carb. 2g • pro. 0g • fat 0g • sat. fat 0g
• chol. 0mg • sod. 76mg • calc. 3mg • fiber 0g*

SPICY CRABMEAT DIP

Makes 1¾ cups

- ⅓ cup whole or reduced-fat milk
- 1 cup lowfat sour cream
- ¼ cup lowfat mayonnaise
- 1 can (6 ounces) crabmeat, drained (about ¾ cup)
- 1 tablespoon fresh chopped chives
- 1½ teaspoons prepared horseradish
- ¼ teaspoon ground white pepper

Place ingredients in the Cuisinart® SmartPower® blender jar in order listed. Place cover on jar. Turn blender on and process on Purée until well blended, about 20 to 25 seconds. Turn blender off. Scrape blender jar with a spatula. Turn blender on and process an additional 20 to 25 seconds until well combined. Refrigerate 1 to 2 hours before serving to develop flavors.

Nutritional information per tablespoon:
Calories 34 (53% from fat) • carb. 2g • pro. 2g • fat 2g • sat. fat 1g
• chol. 15mg • sod. 91mg • calc. 23mg • fiber 0g

CHUNKY GUACAMOLE

Makes 1½ cups

- ¼ cup fresh cilantro leaves
- 1 medium garlic clove, peeled, quartered
- 1 small scallion, trimmed, cut into 1-inch pieces
- ½ small green chili, seeded and quartered
- ¼ teaspoon table salt
- ⅙ teaspoon chili powder
- ½ cup nonfat plain yogurt
- 2 tablespoons fresh lemon juice
- 1 small plum tomato, cut into ½-inch pieces
- 2 small ripe avocados, peeled, pits removed, cut into ½-inch pieces

Place cilantro, garlic, scallion, chili, salt, and chili powder in the Cuisinart® SmartPower® blender jar. Place cover on blender jar. Turn blender on and pulse on Stir until coarsely chopped, about 5 to 6 times. Add yogurt, lemon juice, and tomato pieces. Pulse on Stir until coarsely chopped (about 5 times), then run continuously on Stir until combined, about 10 seconds. Add avocado pieces, and pulse on Stir to combine, about 10 times. Turn blender off. Scrape blender jar with a spatula. Turn blender on. Run continuously on Stir until combined, but still chunky, about 10 seconds. Turn blender off.

Tip: To prevent browning, bury the avocado pit in the center of the mixture for serving or storage.

Nutritional information per tablespoon:
Calories 39 (69% from fat) • carb. 2g • pro. 1g • fat 3g • sat. fat 0g
• chol. 0mg • sod. 30mg • calc. 13mg • fiber 1g

SAUCES/DRESSINGS

CHOCOLATE SAUCE

Makes six tablespoons

- 3 1-ounce squares semisweet chocolate, each broken into 8 pieces
- 1½ teaspoons granulated sugar
- ¼ cup boiling water, cooled for 5 minutes

Place chocolate and sugar in the Cuisinart® SmartPower® blender jar. Place cover on jar. Turn blender on and process on Liquefy until coarsely chopped, about 10 to 15 seconds. Add water, and process on Liquefy until smooth, about 10 seconds. Turn blender off. Serve immediately or cool and refrigerate in an airtight container for up to 4 weeks. Reheat before serving.

Nutritional information per tablespoon:
Calories 85 (53% from fat) • carb. 9g • pro. 1g • fat 5g • sat. fat 3g
• chol. 0mg • sod. 0mg • calc. 5mg • fiber 1g

NONFAT HERBED SALAD DRESSING

Makes one cup

- 1 cup fresh parsley
- 1 small shallot, peeled and quartered
- 1½ tablespoons fresh dill weed
- 1 tablespoon celery seed
- 1 tablespoon fresh cilantro
- 1 tablespoon fresh oregano
- ¼ teaspoon ground white pepper
- ¼ teaspoon kosher salt
- ⅓ cup fat-free milk
- ½ cup fat-free plain yogurt
- 1 tablespoon fresh lemon juice
- 1 tablespoon Dijon mustard
- 1 tablespoon balsamic vinegar

Place parsley, shallot, dill, celery seed, cilantro, oregano, pepper, and salt in the the Cuisinart® SmartPower® blender jar.

Place cover on jar. Turn blender on and pulse on Stir until coarsely chopped, about 5 times. Turn blender off. Scrape jar with a spatula. Turn blender on and pulse on Stir 5 times. Add milk, yogurt, lemon juice, mustard, and vinegar in order listed; process on stir until well blended, about 15 to 20 seconds. Turn blender off. Store in the refrigerator for up to 2 weeks in an airtight container.

Nutritional information per tablespoon:
Calories 12 (0% from fat) • carb. 2g • pro. 1g • fat 0g • sat. fat 0g
• chol. 0mg • sod. 71mg • calc. 38mg • fiber 0g

TOMATO SAUCE

Makes four servings

- 1 can (28 ounces) Italian plum tomatoes, drained**
- 2 medium shallots, peeled, cut into ½-inch pieces**
- ½ teaspoon dried oregano**
- ½ teaspoon table salt**
- ½ teaspoon granulated sugar**

Place ingredients in the Cuisinart® SmartPower® blender jar in order listed. Place cover on jar. Turn blender on and process on Purée until coarsely chopped, about 10 to 15 seconds. Turn blender off. Transfer to skillet or saucepan; simmer over medium-low heat, stirring occasionally, until thick, about 20 to 30 minutes.

NOTE: Purée 20 to 25 seconds for a smoother sauce.

Nutritional information per serving:
Calories 57 (16% from fat) • carb. 10g • pro. 2g • fat 1g • sat. fat 0g
• chol. 0mg • sod. 312mg • calc. 25mg • fiber 2g

PESTO SAUCE

Makes eight servings

- 3 ounces Parmesan cut into ½-inch pieces**
- 3 small garlic cloves, peeled and quartered**
- ¾ cup extra virgin olive oil**
- 2 cups fresh basil leaves, loosely packed**
- ¼ cup toasted pine nuts**

Place cheese in the Cuisinart® SmartPower® blender jar. Place cover on jar. Turn blender on and blend on Liquefy until finely ground, about 30 seconds. Reserve. Add garlic, and blend on Liquefy until minced, about 15 seconds. Add remaining ingredients in order listed including reserved cheese; blend on Liquefy until combined, about 45 to 50 seconds. Turn blender off. Pesto may be stored in refrigerator, in an airtight container, for up to 5 days. It also freezes well.

Nutritional information per serving:
Calories 262 (89% from fat) • carb. 2g • pro. 5g • fat 26g • sat. fat 5g
• chol. 8mg • sod. 202mg • calc. 137mg • fiber 1g

RASPBERRY SAUCE

Makes eight servings

- 12 ounces frozen raspberries, thawed, at room temperature (about 1½ cups)**
- 1 tablespoon granulated sugar**

Place raspberries and sugar in blender jar. Place cover on jar. Turn blender on and pulse 5 times on Purée, then run continuously on purée until smooth, about 10 seconds. Turn blender off. Strain mixture through a fine sieve. Store in an airtight container in the refrigerator. Serve over ice cream or cheesecake.

Nutritional information per serving:
Calories 52 (0% from fat) • carb. 13g • pro. 0g • fat 0g • sat. fat 0g
• chol. 0mg • sod. 0mg • calc. 6mg • fiber 2g

CLASSIC MAYONNAISE WITH COOKED EGGS

Makes 1 cup

- 1 large egg**
- 1 large egg yolk**
- ½ teaspoon granulated sugar**
- ½ teaspoon unbleached, all-purpose flour**
- 1 tablespoon white wine vinegar**
- 1¼ teaspoons dry mustard**
- ½ teaspoon table salt**

- ¼ teaspoon ground white pepper**
⅔ cup (6 ounces) vegetable oil

Have ready a pie plate filled with ice cubes and cold water. Place the whole egg, egg yolk, sugar and flour in the the Cuisinart® SmartPower® blender jar. Place cover on jar and press On button. Process on Stir until combined, about 5 seconds. Transfer to a 7-inch nonstick skillet. Wash the blender jar, blade and lid with hot water and soap; dry.

Over medium heat, using a heat-proof scraper, stir the egg mixture until it thickens to the consistency of a thin custard, about 1 to 1½ minutes. Stir for ½ minute longer, then remove the pan from the heat and place it in the prepared ice water bath, stirring the egg mixture until it is cool.

Add the cooled egg mixture to the blender jar along with the vinegar, dry mustard, salt, and pepper. Process on Stir to blend, about 15 seconds. With the machine running on Stir, add the ⅔ cup of the oil in a very slow, steady stream, taking about 2 minutes. Hold the measured pour lid over the opening while adding oil to prevent splattering. The mayonnaise will thicken gradually. Stop processing once all the oil has been added and the mixture is emulsified. For a thicker mayonnaise, chill for one hour or longer before serving. Store in an airtight container in the refrigerator for up to 5 days.

Variation: Cholesterol-Free Mayonnaise: Substitute ½ cup pasteurized liquid egg substitute for the egg and egg yolk. Omit the cooking/cooling steps. Substitute olive oil for the vegetable oil.

Nutritional information per tablespoon of Classic Mayonnaise:
Calories 93 (96% from fat) • carb. 0g • pro. 1g • fat 10g • sat. fat 1g
• chol. 27mg • sod. 77mg • calc. 3mg • fiber 0g

LOWFAT BLUE CHEESE DRESSING

Makes 1 cup

- 1 cup fresh parsley**
⅓ cup fat-free milk
½ cup fat-free plain yogurt
2 ounces blue cheese, cut into ½-inch pieces
1 tablespoon fresh lemon juice
¼ teaspoon ground white pepper
¼ teaspoon table salt

Place parsley in the Cuisinart® SmartPower® blender jar. Place cover on jar. Turn blender on and pulse on Stir until coarsely chopped, about 5 times. Add remaining ingredients in order listed, and blend on Stir until combined, about 15 to 20 seconds. Turn blender off. Store in the refrigerator for up to 2 weeks in an airtight container.

Nutritional information per tablespoon:
Calories 17 (53% from fat) • carb. 1g • pro. 1g • fat 1g • sat. fat 1g
• chol. 3mg • sod. 96mg • calc. 46mg • fiber 0g

CLASSIC VINAIGRETTE

Makes ¾ cup

- 1 small garlic clove, peeled and quartered**
¾ cup vegetable oil
¼ cup red wine vinegar
1 tablespoon Dijon mustard
⅛ teaspoon ground white pepper
⅛ teaspoon table salt

Place garlic in the Cuisinart® SmartPower® blender jar. Place cover on jar. Turn blender on and process on Liquefy until finely chopped, about 10 seconds. Add remaining ingredients in order listed, and blend on stir until combined, about 15 to 20 seconds. Turn blender off. Store in refrigerator in an airtight container for up to 3 weeks.

Nutritional information per tablespoon:
Calories 126 (100% from fat) • carb. 0g • pro. 0g • fat 14g • sat. fat 2g
• chol. 0mg • sod. 56mg • calc. 2mg • fiber 0g

BATTERS

BUTTERMILK PANCAKES

Makes sixteen 4-inch pancakes

- 1½ cups lowfat buttermilk**
- 2 large eggs**
- 1¼ cups unbleached, all-purpose flour**
- 3 tablespoons vegetable oil**
- 1 tablespoon granulated sugar**
- 1 teaspoon baking soda**
- ½ teaspoon baking powder**
- ½ teaspoon table salt**
- cooking spray**

Place first eight ingredients, in order listed, in the Cuisinart® SmartPower® blender jar (not vegetable oil cooking spray). Place cover on blender jar. Turn blender on and blend on Purée for 10 seconds. Turn blender off. Scrape blender jar with a spatula. Turn blender on and blend on Purée for an additional 15 to 20 seconds. Turn blender off.

Coat a large nonstick skillet or griddle with vegetable oil cooking spray, and heat over medium heat. Pour batter into 4-inch pancakes. When they start to bubble, turn and brown the other side, about 45 seconds. Repeat with remaining batter, coating skillet with cooking spray as necessary.

Nutritional information per pancake:

*Calories 75 (36% from fat) • carb. 9g • pro. 3g • fat 3g • sat. fat 1g
• chol. 27mg • sod. 168mg • calc. 63mg • fiber 0g*

CUISINART® CRÊPES

Makes sixteen crêpes (about 8 to 9 inches in diameter)

- 1⅔ cups warm water**
- 3 tablespoons softened, unsalted butter, cut into 1-inch pieces**
- 1 cup unbleached, all-purpose flour**
- 3 large eggs**
- 1 teaspoon pure vanilla extract**

- ½ teaspoon table salt**
- cooking spray**

Place first six ingredients, in order listed, into the Cuisinart® SmartPower® blender jar (not cooking spray). Place cover on jar. Turn blender on and blend on Mix for 10 seconds. Turn blender off. Scrape blender jar with a spatula. Turn blender on and continue blending on Mix until smooth, about 5 to 10 seconds. Turn blender off.

Refrigerate in a covered container for 2 hours before using. Store in an airtight container in the refrigerator for up to 2 days. Stir well before using.

Coat a 9½-inch nonstick skillet with cooking spray, and place over medium heat. Pour 3 tablespoons batter into skillet, and swirl to coat bottom of the pan evenly with a thin film. Cook about 1 minute on each side, or until lightly browned.

Reserve crêpes. Repeat with remaining batter, coating pan with cooking spray as necessary.

Serve with creamed chicken, fresh berries or sautéed apples.

Nutritional information per crêpe:

*Calories 59 (46% from fat) • carb. 6g • pro. 2g • fat 3g • sat. fat 2g
• chol. 46mg • sod. 107mg • calc. 26mg • fiber 0g*

HONEY WHEAT WAFFLES

Makes six waffles (about 3 cups batter)

- 1½ cups whole milk**
- 2 large eggs**
- ¾ cup plus 2 tablespoons unbleached, all-purpose flour**
- ½ cup whole-wheat flour**
- 4 tablespoons unsalted butter, melted**
- 2 tablespoons honey**
- 1 teaspoon baking powder**
- 1 teaspoon pure vanilla extract**
- ½ teaspoon table salt**
- ¼ teaspoon baking soda**

Preheat waffle iron. Place ingredients in the Cuisinart®

SmartPower® blender jar in order listed. Place cover on jar. Turn blender on and blend on Purée for 10 seconds. Turn blender off. Scrape blender jar with spatula. Turn blender on and continue blending on Purée until smooth, about 10 to 15 seconds. Turn blender off.

Follow manufacturer's instructions for waffle maker to bake waffles.

Nutritional information per waffle:

*Calories 239 (41% from fat) • carb. 28g • pro. 7g • fat 11g • sat. fat 6g
• chol. 96mg • sod. 419mg • calc. 175mg • fiber 2g*

SOUPS

GAZPACHO

Makes five 6-ounce servings

- 2 cups tomato juice, divided**
- 1 celery stalk, peeled, cut into 1-inch pieces**
- 1 medium cucumber, peeled, cut in half lengthwise, seeds removed, in 1-inch pieces**
- 1 garlic clove, peeled, cut into 4 pieces**
- ½ medium green bell pepper, cored, seeded, cut into 1-inch pieces**
- 1 small jalapeño pepper, cut in half, seeds removed, cut into ¼-inch pieces**
- 4 scallions, cut into 1-inch pieces**
- 2 medium tomatoes, seeds removed, each cut into 8 pieces**
- 2 tablespoons fresh lemon juice**
- ¼ teaspoon freshly ground black pepper**

Place 1 cup tomato juice in blender jar. Add celery and next six ingredients. Place cover on jar. Turn blender on and blend on Purée until vegetables are medium-finely chopped, about 10 to 15 seconds. Turn blender off. Place in a large serving bowl, and add remaining 1 cup tomato juice, lemon juice, and pepper; stir to combine. Chill before serving.

Nutritional information per serving:

*Calories 85 (11% from fat) • carb. 16g • pro. 3g • fat 1g • sat. fat 0g
• chol. 0mg • sod. 511mg • calc. 34mg • fiber 2g*

CREAM OF ASPARAGUS SOUP

Makes eight 6-ounce servings

- ¾ cup fresh parsley leaves**
- 3 tablespoons unsalted butter**
- 1 small onion, cut into 1-inch pieces**
- ¾ pound asparagus, trimmed, cut into 1-inch pieces**
- 3 cups chicken stock or broth**
- 1 cup half-and-half**
- 3 teaspoons cornstarch**
- 1½ cups cold water**
- salt and white pepper to taste**

Place parsley in the Cuisinart® SmartPower® blender jar. Place cover on blender jar. Turn blender on and pulse on Purée until coarsely chopped, about 4 to 5 times. Reserve.

Melt butter in a medium saucepan over medium heat. Add onion, and cook until soft but not brown, about 2 to 3 minutes. Add asparagus, stock, and all but 1 tablespoon of reserved parsley. Cover; bring to a boil over medium-high heat. Reduce heat to low and cook, partially covered, until asparagus is tender, about 10 to 12 minutes.

Drain vegetables, being sure to reserve the cooking liquid. Allow cooking liquid to cool 5 minutes. Add 1 cup of the cooking liquid and half of the solids to the blender jar. Place cover on blender jar. Turn blender on and blend on Liquefy until smooth, about 25 to 30 seconds. Turn blender off. Return the puréed vegetable mixture to the saucepan. Repeat with remaining 1 cup liquid and vegetables. Add remaining cooking liquid and half-and-half to puréed vegetables in the saucepan; stir to combine. Stir cornstarch into water, and add to soup. Cook, stirring often, over medium heat, until soup thickens, about 6 to 8 minutes. Do not boil. Adjust seasonings to taste; garnish with remaining parsley, and serve.

Nutritional information per serving:

*Calories 112 (64% from fat) • carb. 7g • pro. 3g • fat 8g • sat. fat 5g
• chol. 23mg • sod. 610mg • calc. 61mg • fiber 2g*

POTATO-LEEK SOUP

Makes four 6-ounce servings

- 1** **tablespoon unsalted butter**
- 2** **medium leeks, whites only, sliced horizontally and cut into 1-inch pieces**
- 1** **small onion, in 1-inch pieces**
- 2** **medium potatoes, peeled, cut into 1-inch pieces**
- 1¾** **cups reduced-sodium chicken broth**
- ½** **cup water**
- ½** **teaspoon table salt**
- ¼** **teaspoon ground white pepper**
- 3** **tablespoons chopped chives (optional)**

Melt butter in a medium saucepan over medium heat. Add leeks and onion; sauté until soft but not brown, about 5 to 8 minutes; stir occasionally. Add potatoes, broth, and water; cover; bring to a boil over medium-high heat. Reduce heat to low, and simmer, uncovered, until potatoes are soft, about 10 to 15 minutes.

Drain vegetables, being sure to reserve the cooking liquid. Allow cooking liquid to cool 5 minutes. Add half of the cooking liquid and half of the solids to the Cuisinart® SmartPower® blender jar. Place cover on jar. Turn blender on and blend on Liquefy until smooth, about 15 to 20 seconds. Turn blender off. Return the puréed vegetable mixture to the saucepan. Repeat with remaining liquid and vegetables and return vegetable mixture to saucepan. Add salt and pepper; stir to combine. Garnish with chopped chives, if desired.

Nutritional information per serving:

*Calories 208 (17% from fat) • carb. 38g • pro. 5g • fat 4g • sat. fat 1g
• chol. 0mg • sod. 380mg • calc. 48mg • fiber 4g*

CREAMY CANTALOUPE SOUP

Makes five 6-ounce servings

- ½** **cup orange juice**
- 1** **medium cantaloupe, seeds and peel removed, cut into 1-inch pieces**
- 1** **cup plain nonfat yogurt**
- 2** **tablespoons granulated sugar***
- 2** **tablespoons port wine (optional)**

2 **tablespoons fresh mint leaves**

Place orange juice and cantaloupe in the Cuisinart® SmartPower® blender jar. Place cover on jar. Turn blender on and blend on Purée until smooth, about 20 to 25 seconds. Add yogurt, sugar, and wine (if using). Blend on Purée until smooth, about 15 seconds. Turn blender off. Serve chilled. Garnish with mint leaves.

*Use less sugar if the cantaloupe is naturally sweet.

Nutritional information per serving:

*Calories 96 (0% from fat) • carb. 20g • pro. 4g • fat 0g • sat. fat 0g
• chol. 1mg • sod. 45mg • calc. 115mg • fiber 1g*

CORN CHOWDER

Makes seven 6-ounce servings

- 1** **tablespoon unsalted butter**
- 1** **medium leek, white only, washed, cut into 1-inch pieces**
- 1** **medium onion, cut into ¼-inch pieces**
- 2** **celery stalks, peeled, cut into ¼-inch pieces**
- 1** **medium potato (about 9 ounces), peeled, cut into ½-inch pieces**
- 1½** **cups reduced-sodium chicken broth**
- 1** **bay leaf**
- ¼** **teaspoon dried thyme**
- 1⅓** **cups reduced-fat milk**
- 2** **cups corn kernels (fresh or frozen; thaw if frozen) divided**
- salt and pepper to taste**

Melt butter in a medium saucepan over medium heat. Add leek and onion; cook over medium heat for 3 minutes. Add celery, and sauté until soft, about 2 minutes. Add potato, broth, bay leaf, and thyme. Cover; bring to a boil over medium-high heat. Reduce heat to low, and cook, partially covered, until potato is tender, about 8 to 10 minutes.

Place milk and 1 cup corn kernels in the Cuisinart® SmartPower® blender jar. Place cover on jar. Turn blender on and blend on Liquefy until well combined, about 25 to 30 seconds. Turn blender off. Add milk mixture and remaining corn to saucepan. Season with salt and pepper, if desired. Cook gently over low

heat until heated through. Remove bay leaf before serving.

Nutritional information per serving:

*Calories 208 (17% from fat) • carb. 36g • pro. 7g • fat 4g • sat. fat 2g
• chol. 8mg • sod. 290mg • calc. 93mg • fiber 3g*

DESSERTS

ESPRESSO GRANITA

Makes six ½-cup servings

- 2 cups hot brewed espresso**
- ½ cup granulated sugar**
- 1 cup chilled coffee**

Combine espresso and sugar in a small bowl until sugar dissolves. Pour into ice cube trays, and freeze until solid, about 8 hours. Place chilled coffee and 10 espresso cubes in the Cuisinart® SmartPower® blender jar. Place cover on jar. Turn blender on and blend on Liquefy until thick, about 20 to 30 seconds. Turn blender off. Add remaining ice cubes. Turn blender on and blend until thick, about 20 seconds. Turn blender off. Serve immediately in well-chilled parfait cups. Top with a dollop of whipped cream.

Nutritional information per serving:

*Calories 68 (0% from fat) • carb. 17g • pro. 0g • fat 0g • sat. fat 0g
• chol. 0mg • sod. 1mg • calc. 3mg • fiber 0mg*

FRESH LEMON GRANITA

Makes eight ½-cup servings

- 2 cups granulated sugar**
- 2 cups water**
- 1½ cups fresh lemon juice (juice of about 6 lemons)**
- 1 tablespoon grated lemon zest***

Combine sugar and water in a medium saucepan, and bring to a boil over medium-high heat. Reduce heat to low, and simmer until sugar dissolves, about 3 to 4 minutes. Cool completely.** When cool, add lemon juice and zest; stir to combine. Pour

into ice cube trays, and freeze until solid, about 8 hours. Place 10 frozen cubes in blender jar. Place cover on blender jar. Turn blender on and press Ice Crush button 10 times or until ice is the consistency of snow. Continue crushing 10 cubes at a time until all are crushed. Turn blender off. Spoon into well-chilled parfait cups and serve immediately.

* Zest is the colored part of the citrus rind. Do not use the white pith. For best results, remove zest from the lemon with a vegetable peeler.

** Place mixture in a covered container, and store in the refrigerator overnight, or chill over an ice bath for 30 minutes.

Nutritional information per serving:

*Calories 216 (0% from fat) • carb. 54g • pro. 0g • fat 0g • sat. fat 0g
• chol. 0mg • sod. 1mg • calc. 6mg • fiber 0mg*

LEMON RICOTTA CHEESECAKE WITH RASPBERRY SAUCE

Makes eight servings (one 9-inch cheesecake)

- 3 whole graham crackers**
- 1 tablespoon cold unsalted butter, cut into 8 pieces**
- 1 tablespoon granulated sugar**
- 4 strips lemon zest, cut in half**
- ½ cup liquid egg substitute**
- 6 tablespoons fresh lemon juice**
- 30 ounces part-skim ricotta cheese**
- ½ cup granulated sugar, divided**

Preheat oven to 325°F. Cover the outside of 9-inch springform pan with foil.

Break each graham cracker into 8 pieces and add to the Cuisinart® SmartPower® blender jar. Place cover on jar. Turn blender on and blend on Mix until crushed, about 10 to 15 seconds. Add butter and 1 tablespoon sugar; blend on Mix until combined, about 10 to 15 seconds. Turn blender off. Press mixture into bottom of pan, and bake 10 minutes.

Add lemon zest and 1 teaspoon sugar to clean, dry blender jar. Place cover on blender jar. Turn blender on and blend on Liquefy for 15 to 20 seconds. Add egg substitute and remaining ingredients in the order listed; blend on Mix for 60 to 75 seconds. (It may look as if the ingredients are not mixing; however, the blender is working. After about 30 seconds, the mixture will start to circulate in the blender jar.) Turn blender off. Pour into pre-baked crust, and bake until firm, about 1 hour. Cool completely on a wire rack, and then refrigerate at least 6 hours before serving. Serve with raspberry sauce (see page 15).

Nutritional information per serving (cheesecake only):

*Calories 251 (39% from fat) • carb. 24g • pro. 14g • fat 11g • sat. fat 6g
• chol. 37mg • sod. 211mg • calc. 299mg • fiber 0mg*

BAKED ALMOND CUSTARD

Makes six servings

- 3 large eggs**
- 1½ cups reduced-fat milk**
- 1 cup evaporated fat-free milk**
- ½ cup granulated sugar**
- 1 teaspoon pure almond extract**
- 6 teaspoons finely chopped or slivered almonds**

Preheat oven to 325°F. Add first five ingredients to the Cuisinart® SmartPower® blender jar (everything but almonds). Place cover on jar. Turn blender on and blend on Mix until combined, about 10 seconds. Turn blender off. Divide mixture among six 6-ounce ramekins or custard cups, filling each about $\frac{3}{4}$ full. Top each with 1 teaspoon almonds. Place ramekins in a 9 x 13 inch baking dish, and add hot water to reach 1 inch up the sides of the ramekins. Bake until a knife inserted in the center comes out clean, about 1 hour. Remove ramekins from water bath, and cool on a wire rack. Cover and chill in the refrigerator before serving.

Nutritional information per serving:

*Calories 181 (25% from fat) • carb. 25g • pro. 9g • fat 5g • sat. fat 2g
• chol. 112mg • sod. 111mg • calc. 230mg • fiber 0mg*

WARRANTY

LIMITED THREE-YEAR WARRANTY

This warranty is available to consumers only. You are a consumer if you own a Cuisinart® SmartPower® 7-Speed Electronic Blender that was purchased at retail for personal, family or household use. Except as otherwise required under applicable law, this warranty is not available to retailers or other commercial purchasers or owners.

We warrant that your Cuisinart® SmartPower® 7-Speed Electronic Blender will be free of defects in materials and workmanship under normal home use for 3 years from the date of original purchase.

We suggest you complete and return the enclosed product registration card promptly to facilitate verification of the date of original purchase. However, return of the product registration card does not eliminate the need for the consumer to maintain the original proof of purchase in order to obtain the warranty benefits. In the event that you do not have proof of purchase date, the purchase date for purposes of this warranty will be the date of manufacture.

If your Cuisinart® SmartPower® 7-Speed Electronic Blender should prove to be defective within the warranty period, we will repair it, or if we think necessary, replace it. To obtain warranty service, simply call our toll-free number 1-800-726-0190 for additional information from our Customer Service Representatives, or send the defective product to Customer Service at Cuisinart, 150 Milford Road, East Windsor, NJ 08520.

To facilitate the speed and accuracy of your return, please enclose \$10.00 for shipping and handling of the product.

Please pay by check or money order (California residents need only supply proof of purchase and should call 1-800-726-0190 for shipping instructions).

NOTE: For added protection and secure handling of any Cuisinart® product that is being returned, we recommend you use a traceable, insured delivery service. Cuisinart cannot be held responsible for in-transit damage or for packages that are not delivered to us. Lost and/or damaged products are not covered under warranty. Please be sure to include your return address, daytime phone number, description of the product defect, product model number (located on bottom of product),

original date of purchase, and any other information pertinent to the product's return.

Your Cuisinart® SmartPower® 7-Speed Electronic Blender has been manufactured to the strictest specifications and has been designed for use with the authorized accessories and replacement parts.

This warranty expressly excludes any defects or damages caused by accessories, replacement parts, or repair service other than those that have been authorized by Cuisinart.

This warranty does not cover any damage caused by accident, misuse, shipment or other ordinary household use.

This warranty excludes all incidental or consequential damages. Some states do not allow the exclusion or limitation of these damages, so these exclusions may not apply to you.

CALIFORNIA RESIDENTS ONLY:

California law provides that for In-Warranty Service, California residents have the option of returning a nonconforming product (A) to the store where it was purchased or (B) to another retail store which sells Cuisinart® products of the same type.

The retail store shall then, at its discretion, either repair the product, refer the consumer to an independent repair facility, replace the product, or refund the purchase price less the amount directly attributable to the consumer's prior usage of the product. If the above two options do not result in the appropriate relief to the consumer, the consumer may then take the product to an independent repair facility if service or repair can be economically accomplished. Cuisinart and not the consumer will be responsible for the reasonable cost of such service, repair, replacement, or refund for nonconforming products under warranty.

California residents may also, according to their preference, return nonconforming products directly to Cuisinart for repair, or if necessary, replacement, by calling our Consumer Service Center toll-free at 1-800-726-0190.

Cuisinart will be responsible for the cost of the repair, replacement, and shipping and handling for such products under warranty.

BEFORE RETURNING YOUR CUISINART® PRODUCT

If you are experiencing problems with your Cuisinart® product, we suggest that you call our Cuisinart® Service Center at 1-800-726-0190 before returning the product to be serviced. If servicing is needed, a Representative can confirm whether the product is under warranty and direct you to the nearest service location.

Important: If the nonconforming product is to be serviced by someone other than Cuisinart's Authorized Service Center, please remind the servicer to call our Consumer Service Center at 1-800-726-0190 to ensure that the problem is properly diagnosed, the product is serviced with the correct parts, and the product is still under warranty.

Cuisinart®

SAVOR THE GOOD LIFE®



Coffeemakers



Food Processors



Toasters



Rice Cookers



Cookware



Grills

Cuisinart offers an extensive assortment of top quality products to make life in the kitchen easier than ever. Try some of our other countertop appliances and cookware, and Savor the Good Life®.

www.cuisinart.com

©2009 Conair Corporation
Cuisinart® is a registered
trademark of the Conair Corporation

Cuisinart
150 Milford Road
East Windsor, NJ 08520
Printed in China

Any trademarks or service marks of third parties used herein are the trademarks or service marks of their respective owners.

09CE13824

G IB-9568A

Version no : IB-9568A

Fold Size: 178X216MM SADDLE STITCHED 24PP

Material (Cover): 157GSM MATT ART PAPER
 (Inside): 120GSM GLOSS ART PAPER

Coating: GLOSS VARNISHING IN COVER

Color (Cover): 4C(CMYK)+1C(BK)
 (Inside): 1C(BK)+1C(BK)

Date: OCT-07-2009 Co-ordinator : Astor You

Hugo Description

PDF version : SPB7 IB-9568A (0,0) BOOK

Hugo Code : MEA0346IB-1A1 Operator : Meng

Color Series: Non

Remark: Quality request (1)

