

**shop·vac®**

# Model - 4045A

Catalog 4011200 (10 Gal.)

4011300 (12 Gal.)

4011400 (16 Gal.)

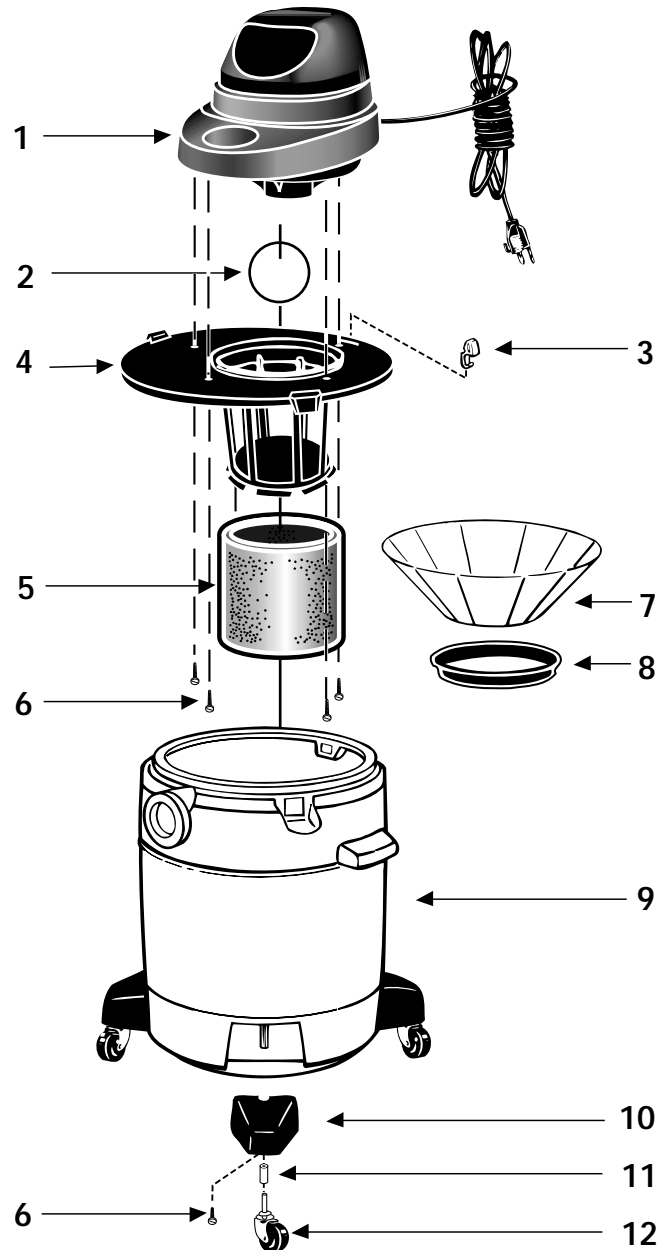

ITEM	DESCRIPTION	PART NO.
1	Power Unit Assembly	8100697
2	Ball Float	0081100
3	Lid Latch	8550101
4	Lid Cage & Latch Assembly	8965724
5	Foam Sleeve	9058562
6	Screw Hex Head #10 x 3/4 Type AB	1503999
7	Reusable Dry Filter	9010762
8	Filter Ring	3006500
9	Tank Assembly (10 gal.) (12 gal.) (16 gal.)	8494497 8494597 8494697
10	Caster Foot	8565000
11	Caster Retainer	8565500
12	Caster	6771200

### STANDARD ACCESSORIES

- 7' x 1<sup>1</sup>/<sub>4</sub>" hose with extension nozzle
  - 2 - 1<sup>1</sup>/<sub>4</sub>" extension wands
  - 10" wet/dry nozzle
  - 10" squeegee insert
- 401-14 ONLY**
- 6' x 2<sup>1</sup>/<sub>2</sub>" hose
  - 2 - 2<sup>1</sup>/<sub>2</sub>" extension wands
  - 6" utility nozzle

### TWO-YEAR HOME USE WARRANTY

Your Shop-Vac® vacuum cleaner is warranted in normal household use, in accordance with the User Manual, against original defects in material and workmanship for a period of two years from date of purchase. Should this product be used for commercial or rental use, a 90 day limited warranty will apply. Shop-Vac Corporation warrants placing this vacuum cleaner in correct operating condition, by repair or parts replacement, during the warranty period, without charge. This warranty does not cover accessories. Use of non-recommended filters and/or accessories may void the manufacturer's warranty.

SC87523-20