

This Owner's Manual is provided and hosted by [Appliance Factory Parts](http://www.appliancefactoryparts.com).

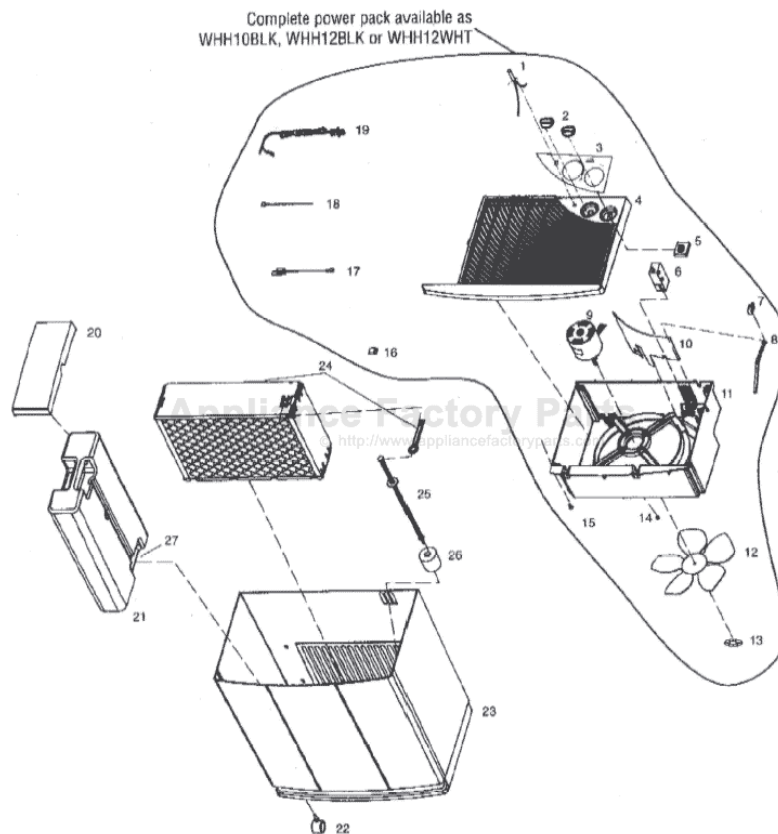

MASTERCool AD150B Owner's Manual

[Shop genuine replacement parts for MASTERCool
AD150B](#)



[Find Your MASTERCool Evaporative Cooler Parts - Select From 135 Models](#)

----- Manual continues below -----

SPECIFICATIONS & SUBMITTAL DATA



FEATURES:

- Heavy gauge galvanized steel cabinet
- Electrostatically applied Polyester resin powder paint finish
- Thermoplastic water reservoir
- Long life media, efficient and self cleaning
- Greater air flow
- Low maintenance
- Made in the U.S.A.



MODELS

- AS/AD 100**
- AS/AD 150**

Project _____

Location _____

Architect _____

Engineer _____

Contractor _____

Submitted By _____ Date _____

Ref. No.	Cooler Model No.	Qty.	CFM	Static Pressure	Motor	HP	Speed	Volts	Phase	Pulley-Belt Kit No.	Pump	Qty.	Volts
1													
2													
3													
4													
5													
6													
7													
8													
9													

Notes

CHAMPION COOLER
 5800 Murray, Little Rock, AR 72209
 1-800-643-8341
 info@championcooler.com

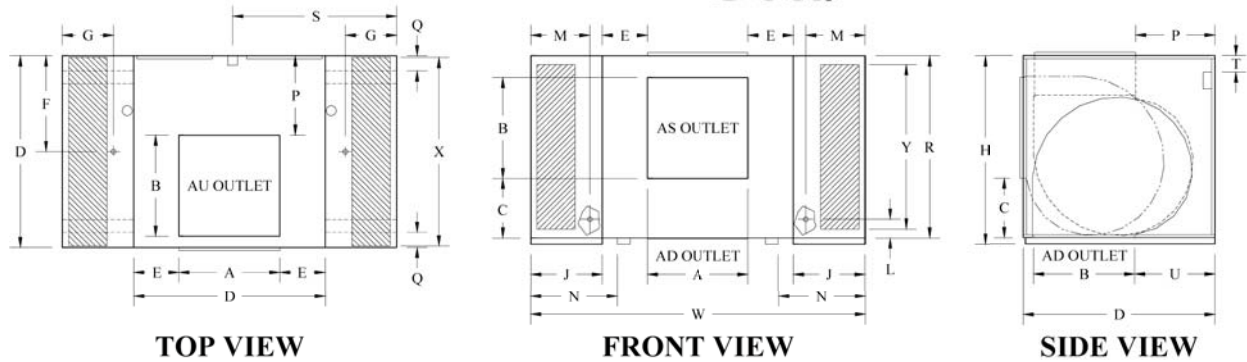

DIMENSIONAL DATA*

BLOWER MODEL NUMBER	WET MUDULE NUMBER	CABINET			DUCT OPENING		DUCT LOCATION				DRAIN LOCATION			WET MODULE			MEDIA DIMENSION		WATER SERVICE		ELECTRIC SERVICE		SKID LOCATIONS		
		H	W	D	A	B	C (AS)	U (AD)	P (AU)	E	F	G	J	X	Y	L	M	S	T	N	Q	R			
AS/AD 100B	100W	44	82	45	21 3/4	21 3/4	13 19/32	21 11/32	N/A	11 5/8	22 1/2	12 1/2	18 1/2	44 3/4	36 5/8	5 7/8	14 3/8	39 7/8	5 3/32	23 1/4	4 3/4	42			
AS/AD 150B	150W	54	85 1/4	48 1/4	26 7/8	26 7/8	16 13/16	19 5/32	N/A	10 11/16	24 1/8	12 1/2	18 1/2	48	46 3/8	5 7/8	14 3/8	41 1/2	5 3/32	23 1/4	4 3/4	52			

* All Measurements in inches.

AS/AD 100				PERFORMANCE Certified Air Delivery At .1" Increments Of External Static Pressure (Inches Static Pressure Water Gauge)																					
MAX B.H.P.	OPER. WGT.	AD BELT	AS BELT	0"		0.1"		0.2"		0.3"		0.4"		0.5"		0.6"		0.7"		0.8"		0.9"		1.0"	
				CFM	RPM	CFM	RPM	CFM	RPM	CFM	RPM	CFM	RPM	CFM	RPM	CFM	RPM	CFM	RPM	CFM	RPM	CFM	RPM	CFM	RPM
1-1/2	757	A76	A82	7745	364	7530	373	7275	384	7004	397	6729	409	6460	422	6193	434	5923	447	5646	460	5357	474	5045	489
2	761	B77	B83	8524	400	8333	408	8109	418	7868	429	7618	441	7368	452	7123	464	6878	475	6638	486	6389	498	6137	510
3	800	B80	B86	9758	458	9596	465	9407	473	9204	482	8990	492	8773	502	8556	512	8340	522	8124	532	7913	542	7698	552
5	804	B81	B87	11569	543	11436	549	11285	555	11121	563	10950	570	10773	578	10592	587	10407	595	10224	603	10039	612	9856	620

Performance shown is for installation type B - Free inlet, Ducted outlet. Power rating (BHP) does not include drive losses.

AS/AD 150				PERFORMANCE Certified Air Delivery At .1" Increments Of External Static Pressure (Inches Static Pressure Water Gauge)																					
MAX B.H.P.	OPER. WGT.	AD BELT	AS BELT	0"		0.1"		0.2"		0.3"		0.4"		0.5"		0.6"		0.7"		0.8"		0.9"		1.0"	
				CFM	RPM	CFM	RPM	CFM	RPM	CFM	RPM	CFM	RPM	CFM	RPM	CFM	RPM	CFM	RPM	CFM	RPM	CFM	RPM	CFM	RPM
2	907	B90	B96	11405	317	10892	328	10463	338	10064	347	9671	357	9276	367	8874	378	8456	390	8006	403	7530	418	7017	436
3	946	B92	B100	13057	363	12600	373	12204	381	11844	390	11497	398	11153	406	10815	415	10467	424	10113	434	9741	444	9361	456
5	950	B93	B100	15480	430	15082	439	14735	446	14410	454	14106	461	13810	468	13520	475	13234	482	12948	489	12659	496	12361	504
7-1/2	984	B95	B101	17719	492	17364	500	17050	507	16756	513	16479	520	16214	526	15947	532	15694	538	15440	544	15188	550	14937	557

Performance shown is for installation type B - Free inlet, Ducted outlet. Power rating (BHP) does not include drive losses.

PULLEY-BELT KIT SELECTION

H.P.	BORE	AD 100 PULLEY-BELT KIT NO.	AS 100 PULLEY-BELT KIT NO.	AD 150 PULLEY-BELT KIT NO.	AS 150 PULLEY-BELT KIT NO.
1 1/2	5/8	3DI-11	3DI-31	-	-
1 1/2	7/8	3DI-10	3DI-30	-	-
2	5/8	3DI-16	3DI-36	3DI-51 (Static < 0.7)	3DI-71 (Static < 0.7)
2	5/8	-	-	3DI-53 (Static > 0.4)	3DI-73 (Static > 0.4)
2	7/8	3DI-15	3DI-35	3DI-50 (Static < 0.7)	3DI-70 (Static < 0.7)
2	7/8	-	-	3DI-52 (Static > 0.4)	3DI-72 (Static > 0.4)
3	1 1/8	3DI-20	3DI-40	3DI-56	3DI-75
5	1 1/8	3DI-25	3DI-45	3DI-60	3DI-80
7 1/2	1 3/8	-	-	3DI-65	3DI-86
10	1 3/8	-	-	-	-

MOTOR SPECIFICATIONS

BLOWER MOTORS		VOLTS	PHASE	MOTOR AMPS*	SHAFT DIA.	MOTOR WGT(LB)	MOTOR PART NO.	BLOWER MOTORS		VOLTS	PHASE	MOTOR AMPS*	SHAFT DIA.	MOTOR WGT(LB)	MOTOR PART NO.
H.P.	SPEED							H.P.	SPEED						
1 1/2	1	115/208-230	1	20/11-10	5/8	41	110459-1	7 1/2	1	230/460	3	22/11	1 3/8	121	110470-9
1 1/2	1	208-230/460	3	6.6-6/3	7/8	40	110463-9								
2	1	115/208-230	1	24/13.2-12	5/8	50	110460-1								
2	1	208-230/460	3	7.5-6.8/3.4	7/8	44	110464-9								
3	1	208-230/460	3	10.6-9.6/4.8	1 1/8	83	110465-9								
5	1	230/460	3	15.2/7.6	1 1/8	87	110466-9								
PUMP PART NO.		VOLTS	AMPS	WATTS	GPM (5FT. HEAD)										
110467		115	1.0	73	4.6										
110468		230	0.58	77	4.6										

*Amperage shown is from National Electrical Code. Use amperage shown on motor nameplate to determine motor protector.

Pumps - 2 Required.