

This Owner's Manual is provided and hosted by [Appliance Factory Parts](#).



Louisiana Grills Little Louie Owner's Manual

[Shop genuine replacement parts for Louisiana Grills
Little Louie](#)



[Find Your Louisiana Grills Grill Parts - Select From 31 Models](#)

----- Manual continues below -----



Cookbook and Owner's Guide



Kentwood

Greenwood

Little Louie

You must read this Owner's Guide before operating your grill



Toll Free 1-877-303-3134
www.dansons.com

- Mesquite
- Hickory
- Apple
- Alder



Dear

Thank you for purchasing your barbecue as a start

Cooking with wood pellets is a circle from the past. Wood was used for cooking and is now back

Think of your grill as a tool to bake, roast, broil, and entertain. It's complete

We'd like to thank you for your pellets.

1. /
2. /

Our loyal customers will find our cookbook and Home Cook new soon

If you are interested, Fax: 1-773-

With a microwave, efficient and Thank you

Canadian Dansons

COPY
Copy
No p
any f

Failure to
serious b

Do not store a spare or disconnected liquid propane cylinder under or near this barbecue.

After a period of storage, and/or non-use, the Louisiana Grill Barbecue should be checked for burner obstructions before use. See instructions in this manual for correct procedures.

Do not operate the Louisiana Grill barbecue if there is a gas leak.

Do not put a barbecue cover or anything flammable on, or in the storage area under the barbecue.

Children should never use your Louisiana Grill barbecue. Accessible parts of the barbecue may be very hot. Keep young children away while it is use.

You should exercise reasonable care when operating your Louisiana Grill barbecue. It will be hot during cooking or cleaning and should never be left unattended or moved while in operation.

Do not use lava or charcoal in your Louisiana Grill.

Never lean over open grill or place hands or fingers on the front edge of the cooking box.

Should a grease fire occur, turn off all burners and leave lid closed until the fire is out.

Do not enlarge valve orifices or burner pots when cleaning the valves or burners " Louisiana Grills " should be cleaned on a regular basis.

Use heat-resistant barbecue mitts or gloves when operating barbecue.

LIQUID PROPANE GAS UNITS/SIDE BURNERS ONLY:

Use the regulator that is supplied with your Louisiana Grill Dual Fuel barbecue.

Liquid propane is not natural gas. The conversion or attempted use of natural gas in a liquid propane unit will void your warranty.

Should the propane burners go out while in operation, turn off all gas valves. Open the lid and wait five minutes before attempting to relight, using the lighting instructions

Do not attempt to disconnect any gas fitting while your barbecue is in operation.

A dented or rusty liquid propane cylinder may be hazardous and should be checked by your liquid propane supplier. Do not use a liquid propane cylinder with a damaged valve.

Although your liquid propane cylinder may appear to be empty, gas may still be present, and the cylinder should be transported and stored accordingly.

If you see, smell or hear the hiss or escaping of gas from the liquid propane cylinder:

Move away from the cylinder.

Do not attempt to correct it yourself.

Call your fire department

CONTENTS

HOW YOUR LOUISIANA GRILL WORKS	5
LITTLE LOUIE / KENTWOOD GRILLS	6
GREENWOOD / GRANDE ISLE GRILLS	7
SPECIAL FEATURES	

ST
STA

FO

Your Lou
technolog
results ev

The perfe
the Start

The auger delivers the pellets to the burn grate. Your **Louisiana Grill** uses "Top Feed" technology which means the auger pushes the wood pellets up above the burn pot area and then the pellets fall down a chute in to the burn area. The top of the auger is an open design, thus reducing the possibilities of "auger jams" and allows for the use of less than premium fuel quality. Adjusting the temperature control switch sets the speed of the auger and the temperature output. The "Electronic Auto Igniter" activates for approximately 30 minutes, or until an operating temperature of 120° F is reached, igniting the pellets in the burn pot. A fan provides combustion air to the burn grate as well as causes air movement in the cooking area, resulting in convection cooking. The fuel burns in the burn grate, hot and intense, somewhat like a forge. The fly ash is directed downward by the "Flame Deflector", and can be cleaned out through the ash drawer. The "Flame Deflector" also protects the food from direct flame and distributes the heat evenly throughout the cooking area. The natural smoke flavour produced by the burning pellets, the smoke produced by the "Grillmate" or "Flavor Guard", and the air circulating throughout the cooking area, combine to give you that savoury flavour that is unique to pellet grills and will win you rave reviews each time you use it.

Tip

Your Louisiana Grill can run efficiently over extended periods of time and at different heat output levels as long as the fuel supply is uninterrupted and *timely cleaning and maintenance is performed.*

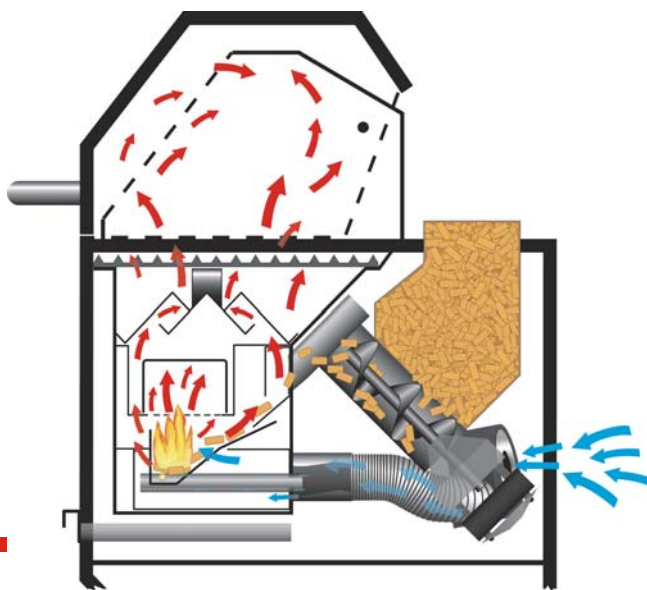
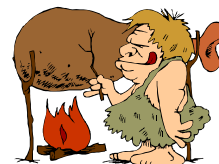

YOUR

NEW

“LITTLE LOUIE” OR “KENTWOOD” CART PELLET BARBECUE . . .

Low CFM
Causes P
Convection

Auto
Elec
elim
mate

Full Ra
gives n
giving

S
th
H
2

Little

Ken

Option



Grillm

YOUR NEW "GREENWOOD" OR "GRAND ISLE" CABINET PELLET GRILL ...

High quality thermostat
Cast iron grills for long life and even heat distribution

Low CFM Blower Fan
Causes pellets to burn and ConvectionOven cooking

Auto Start Button & Electric Igniter
eliminate the need for matches & lighter fluids

Full Range Temperature Control
gives range of 200 to 600 deg F, giving more cooking options

Smoke Switch gives you that savory flavor on demand
Hot smokes at approximately 200 deg F.

Available in paint grade or all stainless steel finishes

Stainless Stay Cool Handle

Double wall construction helps retain heat for all year grilling

Large 10 lb.+ Hopper capacity
Sealed, easy to flip up top (Located on backside of unit)

1 pc "Grill Mate" stainless steel and platinum coated cooking grate
Enhances quality and quantity of smoke. Reduces flare-ups and improves heat response and distribution

Stainless Steel Wrap-around Shelf
offers a durable easy to clean surface

Ash Drawer and Grease Catcher,
makes for no fuss cleaning (located behind the cabinet doors)

Enclosed cabinet area
Large protected storage

Heavy duty construction using stainless & aluminized steel

Large easy-roll wheels **Heavy duty locking casters**

	Heat Output	Cooking Area	Electric	Size H x W x D
Greenwood	approx. 45,000 BTU's	408 sq. Inches Large enough to entertain	110 Volt 3 prong plug	48" x 47" x 35"
Grand Isle	approx. 50,000 BTU's	612 sq. Inches Large enough for family and friends	110 Volt 3 prong plug	48" x 57" x 35"

Options:



Reduces flare-ups
Prevents grease corrosion
Improves heat distribution

Grillmate
(Standard on Stainless Steel models)



Custom Fit Grill Cover
Stylish vinyl cover to protect your investment



Your "Little steel "Flavor and is used "V" shaped installed to and the two

When the m that gives fo and the flex control the t unwanted fl

All "Louisian withstand h keep the fla flare-ups. A the heat eve deflector als

The burn po temperature the right cor allow them notched out casing to he

EL
E
Electric no more m

Indica

CAST IRON COOKING GRILLS

Your Louisiana Grill comes complete with cast iron cooking grills. To maintain the excellent searing and grilling performance of your grills, as well as their longevity, some special care and maintenance is required. As with any cast iron cooking tools, PROPER SEASONING is a must.

First time use

Before using any cast iron grill, wash it thoroughly with a mild dishwashing liquid to move the protective wax coating applied for shipping. Rinse with HOT water and dry completely with a soft cloth or paper towel. NEVER WASH IN A DISHWASHER, OR ALLOW THEM TO DRAIN DRY. Now you must season the grills to prevent rust and sticking.

How to “Season”

A solid vegetable shortening or olive oil is recommended for the initial seasoning.

1. Spread a thin coating of solid vegetable shortening or olive oil over the entire surface, including all corners, with a paper towel. Do not use salted fats such as butter or margarine.
2. Preheat your Louisiana Grill for 15 minutes then place the coated grills in the barbecue.
3. Turn your heat setting to medium/ignite and close the lid.
4. Allow your Louisiana Grill to heat the cast iron grills for 1 to 1 ½ hours.
5. Turn off the Feed Rate/Temperature control and let your Louisiana Grill go through the SHUT DOWN cycle and cool completely.
6. Your cast iron grills are now “Seasoned” and ready for use.

Maintenance (every time you grill)

DO NOT do a prolong burn-off after you grill. Approximately 5 minutes will do, as this burn-off is required to help in the maintenance of the “Grillmate” cooking grates (not available on all models) Leaving the cooking residues on the cast iron grills does leave a protective coating on the iron. Then do a burn-off or a 10 – 15 minute preheat just before your next cook out. This will vaporize most everything on the grill, then brush off charred residues with a steel brush rather than a brass brush.

Rust

If rust does appear, it is an indication that the cast iron grills have not been seasoned properly or enough. Or, if the extended burn-off method has been used after grilling, the seasoning has also been burned off. You must begin the seasoning process again, after brushing all rust away with a steel wire brush

TIP

The more you use your Louisiana Grill and the cast iron grills, the easier the maintenance will be. If you store your cast iron grills for extended periods of time, grease them very lightly with vegetable shortening or olive oil, then wipe them dry with a paper towel. Store them in a dry place.

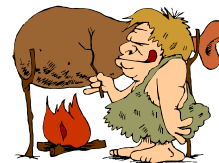

Select L
“Grill Ma
control in
or other
to the ur
ups are



Frequ

What is

The “Grill
platinum.
can reach
unit to bu

What a

1. Eil
fla
2. En
juic
3. Pr
sm
4. Im
bu
5. Im
ex
su
fo
6. In
bu
co

Do I ne

No, simpl
that no ex
backs, or

“GRILL MATE” COOKING GRATE

Operation:

1. Follow the instructions for lighting your Louisiana Grill. (see details elsewhere in this manual).
2. Allow the grill to preheat for 10 minutes.
3. Grill as you normally would. You will notice an increased amount of smoke, which adds that “smoked and savory” flavor to your food.
4. If you notice any grease, which ignites on the cooking grate, turn the temperature down in order to achieve maximum performance.

Note: because of the nature of the “Grillmate” cooking grate, low temperature settings will cook as quickly and thoroughly as high one’s, in turn, greatly reducing your operating costs.

5. After grilling you should allow the unit to clean itself. (see details in the following section).



Use and Care

Your “Grillmate” cooking grate will give you many years of flavourful service, however, you should read and observe the following precautions:

The “Grillmate” is a self-cleaning structure and requires only a 15-minute cleaning cycle on the high setting. We normally would recommend this after each grilling. However, many users who grill frequently have found that this can lead to excessive fuel consumption, and is not recommended because of the cast iron grills. We have developed the following cleaning procedure, which works well, but depending on your grilling habits, may result in reduced performance.

Normal Cleaning Method:

After the completion of grilling, turn the grill to high until only an occasional wisp of smoke is seen (about 5 minutes). This will remove most of the material that builds up on the “Grillmate”. The next time you grill allow the grill to preheat on high for 5 – 10 minutes to complete the cleaning cycle.

Periodic Thorough Cleaning Method:

At least once every 5 to 6 uses (more if you experience heavy build-up & less if you do not) you should perform a complete cleaning cycle. This consists of turning the grill on high for a 15 – 20 minute period. Allow the grill to cool completely, remove the cast iron grill(s) and brush the Grill Mate with a soft bristled brush (paintbrush or old BBQ brush). **DO NOT USE A STIFF OR WIRE BRISTLED BRUSH OR CLEANING SOLUTIONS. THE USE OF THESE ITEMS WILL VOID THE WARRANTY ON YOUR GRILL MATE.**

Alternate Cleaning Methods:

1. The “Grillmate” may be placed in your self-cleaning oven and subjected to a “clean” cycle.
2. The “Grillmate” may be gently rinsed with a garden hose. If you have hard or chlorinated water, you should rinse the “Grillmate” with distilled water prior to reinstalling in the grill.



Your Louisiana Grill is designed for long life and low maintenance. Regular cleaning and proper use will add greatly to the life of your grill.

“Louisiana Grills” is a registered trademark of Louisiana Grills, Inc. The vinyl cover is a separate purchase.

Helpful Hints

DO's

Keep your Louisiana Grill clean and free of any dirt or food residue. Use Armor-All, or a similar product, to keep the grill looking like new.

Have any questions? Call 1-800-543-7777.

Keep away from children.

Keep all sharp edges covered.

DO NOT

Cover your grill with a vinyl cover.

Store anything on the grill.

Permit leaves or twigs to fall on the grill.

Use high-pressure water to clean the grill.

Use wire brushes to clean the grill.

ABOUT WOOD PELLETS

They are no thicker than the eraser on the end of a pencil, people who see them for the first time think they look like rabbit food, but there is nothing small about the heat energy in a wood pellet. These clean burning wood pellets generate about 8200 BTU's per pound with very little ash and low moisture content.

Wood pellets are not new; they have been around for a long time used in industrial, commercial and residential heating appliances. There are more than 125 active pellet mill operations in United States and Canada, producing millions of pounds of pellet each year.

- Mesquite
- Hickory
- Apple
- Alder



Barbeque wood pellets are produced in the same manner as wood pellet fuel is produced for home heating. Pure raw material (sawdust) is pulverized with a hammer mill and then dried. The dried material is then processed under heat and pressure. Lignin, which is the natural glue, which holds plant fibre together, softens above 100° C, permitting the material to change shape. The hot lignin then acts like a binding agent to bond the pellet together. The heated material then goes through a hard steel die, much like a meat grinder,

which rotates against rollers forcing the material through the die with pressure over 3 000 PSI. As the pellet is forced through the die it is sheared off at a specific maximum length, cooled, screened, vacuumed, and then bagged into 20 lb bags.

General specifications for barbeque pellets are: 100% hardwood, 1" long or less in length, 1/4" diameter, less than 2% ash content, less than 2% fines, under 10% moisture content, approx. 8200 BTU's per lb. and about 40 lbs per cubic ft. density.

Mesquite, from the Aztex "mizquiti" (which means "the honey tree"); true to its name gives a delicate, subtle, sweet flavour to grilled foods- especially good with poultry and seafood.

Hickory intensifies the flavour of food with a robust, tangy taste that is better suited to red meat than to poultry and fish.

Apple or fruitwoods, many from orchards destroyed by fire or old age, are a big hit. Like its mesquite counterpart, the heaviest branches of the apple tree is heated to kill insects, then chipped, made into pellets, and packaged for retail. Apple or any fruitwood, adds a smoky, mild sweetness to everything that you cook or is highly recommended for any baking.

	Beef	Buffalo	Chicken	Turkey	Fish	Lamb	Pork	Baking
Alder	x	X	x	x	X	x	X	X
Apple			x	x			X	X
Hickory	x	X	x	x			X	
Mesquite	x	X	x	x	X			



Your new
Please no
inspection

TIP
Be sure to
Report an
Shipping

Tool Re
1 - Phillip

Proced
Open the
shipping
Gently re

ATTENTIO
Care mu

Tool Re
1 - Phillip

Unpack
1.

- 2.
- 3.
- 4.

Proced
Install the

The
scr
scr

Install the
Remove t
at
sh

Now insta
Connect t
be
tw

Install the
Re-install
be

INITIAL SET-UP PROCEDURES

Please note that during shipping some movement may have taken place, so a complete visual inspection is required. Please follow these Initial Set-up procedures to insure the proper and safe operation of your grill.

Note: Do not plug your grill into an electrical outlet until this procedure is complete.

TIP: It is recommended practise to always go through the INITIAL SET UP Procedures after every 5 to 10 uses. This will ensure proper ignition and continuous happy grilling experiences.

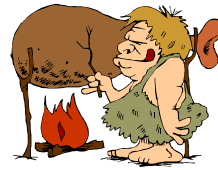

Open the GRILL LID and remove the Cast Iron Cooking Grills. "Little Louie" comes with 1 grill, the "Kentwood" and "Greenwood" models come with 2 sections and the "Grande Isle" comes with 3.

Remove the "Grillmate" or stainless steel "Flavor Guard" Cooking surface.

Remove the Flame Deflector. This is the "U" shaped stainless steel metal piece sitting over the burn grate. The "U" shape sits upside down to help distribute the heat and to keep fly ash to a minimum. The flame deflector also keeps the flame from making direct contact with your cooking.

Remove the stainless steel burn grate and check the burn pot area, remove any foreign items. Ensure that the air holes in the grate are clear of debris.

Re-install the burn grate. Ensure that the stainless steel grate is setting down and snug in the burn pot with the two igniter holes visible and clear of obstructions, in the bottom of the grate. If the grate does not sit firmly in the pot area you will have to adjust the grate adjustment tab.

Re-install the flame deflector. This mounts back on the side brackets located on each side of the burn area. The opening of the "U" shape should be facing downwards, and should be centered over the burn grate.

Re-install the Cooking Grates: For the "Grillmate" ensure that the grill with the small round holes is facing upward and the basket weave pattern is facing downward, towards the flame deflector and burn area. For re-installing the "Flavor Guard", **the pointed top of the "V" shaped runners and the two pull-tabs must point upward toward the cast iron cooking grills.**

Reinstall the Cast Iron Grills.

Open the Pellet Hopper Lid, found in the rear of your grill, behind the lid. Check for any foreign objects.

Fill the hopper with your choice of wood pellet fuel. Replace the hopper lid.

Plug your Louisiana Grill into the nearest AC outlet.

You are now ready to push that start button and enjoy that savory taste of pellet convection cooking.



With toda
important
fat metho

Through
settings.
your Loui
that you d

WARNING:
Do not m
complete

Followin
perfectio

Operat
Initial B
Before co
foreign m
removed,
turn the c

Lighting
It is recor
uses. Th
found in c
blocking t

Should yo
match an

Pre-Hea
It is extre
cast iron
food is pu
longer pe
Always p
knob to P
your food

Lid Pos
Always c
cook fas
down yo

Cast Iron Grates

The best chefs use cast iron grills because cast iron heats evenly, and quickly sears food to lock in the juices and natural flavour. Cast Iron is also ideal for great steak house markings. (see Cast Iron Grate Feature elsewhere in this manual).

Cooking Settings

Pre Heat

The **PREHEAT** setting will give an oven temperature of over 600°F (316°C), depending on weather conditions. This setting is used to quickly preheat your grill as well as to finish the cleaning cycles for the cast iron grills and the “Grillmate”. Could also be used as a HIGH setting in extreme cold weather conditions.

High

The **HIGH** setting will give an oven temperature of approximately 500°F – 550°F, depending on the weather. This setting is ideal for quickly searing steaks and chops.

Medium / Ignite

The **MEDIUM / IGNITE** setting will give an oven temperature of approximately 350°F (177°C) when the lid is closed and the weather conditions permit. This setting is recommended for finishing cooking steaks, hamburgers, chops, etc. This setting is also used to **IGNITE** your Louisiana Grill. This setting allows just enough pellets to feed and the proper air to transfer heat from the igniter to start the wood pellet fuel.

Low

The **LOW** setting will give an approximate oven temperature of 310°F to 350°F (154°C – 177°C).

Smoke

The **SMOKE** setting will give an approximate oven temperature of 200°F to 220°F. This setting is used to slow roast and the increase the smoke flavour of your favourite food. Highly recommended for that **BIG BIRD** at Christmas, Easter, Thanksgiving, Birthdays, and all other important holidays.

TIP: The temperatures listed above are all approximate and will be affected by the outside temperature, the amount of wind present, and the length and type of pellet fuel being used.

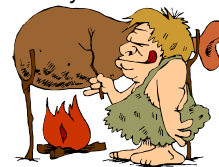

After Cooking

One of the greatest benefits of your Louisiana Grill is the minimal clean up required. When you are finished cooking and waiting just a little while to let the flavour set in that prime selection of meat, turn the control knob to **PREHEAT** for 5 minutes. Let the grill heat up, then turn the knob all the way counter clockwise, past the **OFF** click and you're **DONE**. A quick wipe up of the stainless steel counter top, using a cloth and mild soap, let the unit cool and put your Louisiana Grill to bed with the optional **GRILL COVER**.

CAUTION: Grease fires are caused by not properly maintaining your grill, or failing to clean your clean out drawer on a consistent basis. In the unlikely event you experience a grease fire while cooking, keep the lid closed. If it does not go out in a very short time, open the lid and lightly sprinkle baking soda on the fire. Be careful not to burn yourself. If this does not work, then carefully remove the food from the grates, turn the temperature control to **OFF** and shut the lid until the fire is completely out.



TIP: It is
UP Proc
ignition a

Autom

Place CO

Turn the

Press the

•

•

•

•

Your grill

The grill
flame wil
any hot s

Turn the

CAUTION
FEED CO

After the

NOTE: D
temperat
on the CO

NEVER a
burned.
controls,
automati
normal L

NOTE: If
approxim
unburned
out of the

Manual Start Up

If for any reason your electric igniter fails, you can start your “Louisiana Grill” manually.

Remove the cast iron grills, and the “Grillmate” or “Flavor Guard”. You will also have to remove the Stainless Steel flame deflector.

Inspect the stainless steel burn pot to ensure that is clean of debris and that the ignitor air holes are not obstructed. Also check to ensure proper placement of the burn grate.

Place a small handful of pellets in the bottom of the burn grate.

Add a small amount of solid fuel fire starter, such as those made from sawdust and wax or use wood shavings. Add a small amount of pellets over the fire starter.

CAUTION: DO NOT USE ANY FLAMMABLE LIQUIDS SUCH A GASOLINE, GASOLINE-TYPE LANTERN FUEL, KEROSENE, CHARCOAL LIGHTER FLUID, OR SIMILAR LIQUIDS TO START OR FRESHEN-UP THE FIRE! KEEP ALL SUCH LIQUIDS WELL AWAY FROM THE GRILL WHILE IT IS IN USE.

Light the fire starter.

Place **COOKING MODE SWITCH** to the **COOK** position.

Turn the **FEED CONTROL** (temperature output) to the **IGNITE** position.

Press the **START BUTTON**.

- This initiates the start up cycle, which includes; the auger will start to turn, the ignitor indicator will light and the combustion fan will start.
- The grill now has 30 minutes to produce heat before it will shut down automatically.
- The ignitor indicator will turn off automatically when you're the temperature sensor switch reaches 120°F or 30 minutes.

Quickly and carefully, replace the stainless steel flame deflector, the “Grillmate” or “Flavor Enhancer” and the cast iron cooking grills. Your grill will begin to produce smoke while the start up cycle is taking place. Close the lid.

The grill is operational once the smoke as cleared. To check open the lid of your grill and a flame reflection will be visible in the burn pot area. You will be able to view this without having to touch any hot surfaces.

Turn the **FUEL FEED** to **PREHEAT** and allow unit to preheat at 500 to 600°F for approximately 10 minutes.

CAUTION: If excessive flame is visible i.e. **FLAME DEFLECTOR** is glowing bright red, turn the **FEED CONTROL** down.

NOTE: If the fire does not start, the Grill will continue to feed pellets and the fan will run for approximately 30 minutes. The grill will then automatically shut off. If this happens, some unburned pellets will build up in the burn grate. To restart the fire, clean the excess pellets out of the burn grate and follow the above steps.



Smoking
wood pe
smoking
is where
“Louisia

TIP: To
immedia
penetra

The smo
such as
smoking
prefer th
serving.

TO AC

Follow th
PROCED

After the
you have
MODE S
normal F

When fin
mode.

Your “Lo
you man
the grill a
minutes

Deactiva

When fin
position.

When co
will hear

Once the
DOWN c
combust

COLD WEATHER COOKING

Just because the bright coloured leaves are gone and the golf clubs put away for another season doesn't mean you have to stop barbecuing. The clean crisp fresh air and the heavenly aroma of flavoured wood pellets and food cooking may be just what the doctor ordered to cure those winter blahs. Holiday grilling also frees up your oven space for other important menu items. Following are a few suggestions on how to enjoy your grill throughout those cooler months.

- ORGANIZE. – Get everything you require ready in the kitchen before you head out to the great outdoors. Put what you need on a tray, bundle up tight, and go for it!
- During the winter move your grill to an area that is out of the wind and cold. Check local bylaws regarding the proximity of your grill in relation to your home and/or other structures.
- **Caution: Never grill in an unventilated area!**
- To help you keep track of the outside temperature, you should place an outdoor thermometer close to your cooking area. This will help in determine how long it will take to cook your food.
- You may want to keep a log or little written history on what you cooked, the temperature outside, and the results. This will help latter down the road to help you determine what to cook and how long it will take.
- When cooking in cold weather, it is better to increase your pre-heating time by at least 20 minutes.
- Avoid lifting the grill lid any more than necessary. Cold gusts of wind can completely cool your grill temperature. Be flexible with your serving time; add about 10 – 15 minutes extra cooking time each time you open the lid.
- As always, use a meat thermometer to determine the internal temperature of your foods.
- Because the nights come sooner in the colder months, it is a good ideal to work in a lighted area or to have a light or flashlight close by.
- Have a heated platter and maybe a cover ready to help keep your food warm while making the trip back inside.
- Some of your better foods for winter cooking are those that require little attention, like roasts, whole chicken, ribs, and turkey. Make you meal preparation even easier by adding vegetables and potatoes.

HOT WEATHER COOKING

Following are a few tips on hot weather cooking. As it gets hotter outside, not only will the cooking times of your food decrease but the cooking time on you decrease. Proper dress is a must. Shorts, T-shirt, sandals, hat, apron and a generous slab of suntan lotion go without say. Don't forget the big tall cool drink; we don't want the chef to become dehydrated.

- ORGANIZE – You don't have to serve a huge seven-course meal. You don't want to be cleaning your entire kitchen after every meal. Timing is everything to cooking outside and remember practise does make perfect. So practise lots!!!
- Adjust your cooking temperatures downward. This helps to avoid those unwanted flare-ups.
- As always, use a meat thermometer to determine the internal temperature of your foods. This helps in preventing your meat from over cooking and drying out.
- Even in hot weather, it is still better to cook with the lid of your grill down.
- You can keep foods hot by wrapping them in foil and placing them in an insulated cooler. Stuff crumpled up newspaper around the foil and this will keep food hot for a good 3 to 4 hours.
- Try to keep your menu on the lighter side. So you can enjoy the warm temperatures and quality family times.



There are tv
entire grill, i
from that ba

TIP

**Be diligent
grill will ad**

Starting

**A little time
grill but wi
Grill"! Mos**

Stainles

ALWAYS cl
into the met
quick swipe
surfaces or
many comm

Paint Gr

Be sure to p
and allows t
water. Som
flat black st
makes man
most pellet

Cast Iron

When new,
information

"Grill Ma

After the co
(about 5 mi
time you gri
See the sec

"Flavor

This require
time you ma
initial set-up

The Firebox

Because the firebox is used to channel the fan forced air into the burn grate, there is very little maintenance to be done in this area. Occasionally you may either vacuum or brush out any build-up of ash or burn debris that has fallen below the burn grate. You will also want to visually check the air holes in the igniter tube. Clean any debris or blockage out of both areas to ensure a perfect start.

Stainless Steel Burn Grate

Periodically check the air holes found in the sides of the burn grate for any blockages or build-ups. Using a wire brush or flat-head screwdriver, scrape off any build up or blockage. When reinstalling the grate also confirm the proper positioning in the burn pot. The grate should be level from side to side and from front to back as well as should have a snug but not tight fit. You may have to adjust the tab, found under the front lip, using a pair of pliers to move the tab inward or outward.

- A. Burn Box
Combustion air brought into the Backside and through the burn Grate bottom, back, and front
- B. "SUPER" Grate
Stainless steel construction,
Solid bottom notched for igniter
And air holes on front and back
- C. Adjustable Tab
Used to fine tune and Level grate

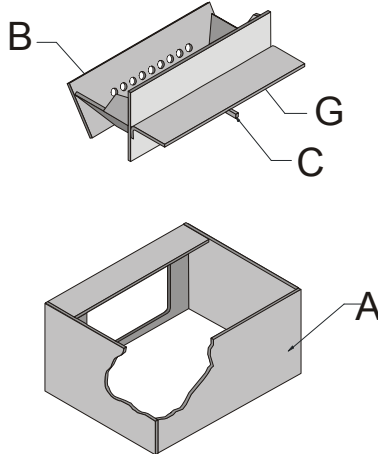

Ash/Grease Tray

Always be sure the ash/grease pull out pan is clean and free of debris. To make cleaning a breeze you can line the ash catcher with foil wrap. During the warmer months empty any grease build-up on a more frequent basis to avoid it from going rancid and to avoid having any extra creatures enjoying your grill.

Slowing Down . . . Not Putting Away for the Season

We recommend that at least once a month, while your grill is cold, that you should perform not only the above maintenance procedures, but also include the following:

Using a stiff vegetable brush knock-off any built-up scale on the inside walls of your grill. Check the inside of the lid, the smoke deflector, and the inside walls of the cooking area.

Using an old paintbrush, brush off any ash build-up found inside the firebox, grate, and flame deflector areas.

Finally give your entire grill a good cleaning with a shop vac.



The "Louisiana Grills" carries a five-year warranty against defects and damaged components against damage.

Condition

1. Due to the nature of the product, there may be some wear and tear on the grill over time.
2. The grill is designed to be used outdoors and should be protected from the elements.
3. Regular cleaning and maintenance are required to ensure the grill is in good condition.
4. The grill should be stored in a dry, covered area during the winter months.
5. The grill should be inspected for any signs of damage or wear before use.
6. The grill should be used according to the instructions provided in the user manual.

LIMITED WARRANTY

Exceptions to the Limited Warranty

There is no written or implied performance warranty on “Louisiana Grills” appliances, as the manufacturer has no control over the installation, operations, cleaning, maintenance or the type of fuel burned.

This limited warranty will not apply nor will CCI assume responsibility if your appliance has not been installed, operated, cleaned and maintained in strict accordance with the manufacturer's instructions. Burning other than quality wood pellets may void the warranty. The warranty does not cover damage or breakage due to misuse, improper handling or modifications.

NEITHER THE MANUFACTURER, NOR THE SUPPLIERS TO THE PURCHASER, ACCEPTS RESPONSIBILITY, LEGAL OR OTHERWISE, FOR THE INCIDENTAL OR CONSEQUENTIAL DAMAGE TO THE PROPERTY OR PERSONS RESULTING FROM THE USE OF THIS PRODUCT. ANY WARRANTY IMPLIED BY LAW, INCLUDING BUT NOT LIMITED TO IMPLIED WARRANTIES OF MERCHANTABILITY OR FITNESS, SHALL BE LIMITED TO ONE (1) YEAR FROM THE DATE OF ORIGINAL PURCHASE. WHETHER A CLAIM IS MADE AGAINST THE MANUFACTURER BASED ON THE BREACH OF THIS WARRANTY OR ANY OTHER TYPE OF WARRANTY EXPRESSED OR IMPLIED BY LAW, MANUFACTURER SHALL IN NO EVENT BE LIABLE FOR ANY SPECIAL, INDIRECT, CONSEQUENTIAL OR OTHER DAMAGES OF ANY NATURE WHATSOEVER IN EXCESS OF THE ORIGINAL PURCHASE PRICE OF THIS PRODUCT. ALL WARRANTIES BY MANUFACTURER ARE SET FORTH HEREIN AND NO CLAIM SHALL BE MADE AGAINST MANUFACTURER ON ANY ORAL WARRANTY OR REPRESENTATION.

Some states do not allow the exclusion or limitation of incidental or consequential damages, or limitations of implied warranties, so the limitations or exclusions set forth in this limited warranty may not apply to you. This limited warranty gives you specific legal rights and you may have other rights, which vary from state to state

The limited warranties for 5 (five) years or 2 (two) years are in lieu of all other warranties expressed or implied, at law or otherwise, and CCI does not authorize any person or representative to assume for CCI any obligation or liability in connection with the sale of the wood pellet grill. This means that no warranties, either expressed or implied, are extended to persons who purchase the product from any one other than CCI or an authorized CCI Distributor.

Procedures for Warranty Service

Call your nearest “Louisiana Grills” dealer for repair or replacement of your “in-warranty” parts. Be prepared to furnish the following information:

1. Purchaser's name, model and serial number of grill and date of purchase.
2. An accurate description of the problem.

THIS LIMITED WARRANTY GIVES YOU SPECIFIC LEGAL RIGHTS AND YOU MAY HAVE OTHER RIGHTS, WHICH VARY FROM STATE TO STATE



GRILLING GEAR

DRESS TO PROTECT

Oven Mitts

This has to be one of the most overlooked accessories. Look for ones that are flameproof, and are longer in the sleeve, about 16" in length, this helps protect your arm particularly when basting large cuts of meat, or anytime you open up the cooking hood. They will also protect your bare arms from hot food splatter or grease. Also look for ones that are soil and water repellent, to protect the mitt's appearance against spills and stains.

Apron

The equivalent to the handyman's tool belt. Most good aprons will have an adjustable neck strap for that perfect fit, and lots of pockets for bottles, a towel or two and tools. Should be machine washable.

Shoes

Always wear closed shoes, not steel toed unless your cooking skills need refinement, to protect your feet from dripping grease or falling utensils.

THE RIGHT TOOLS FOR THE JOB

Meat Thermometer (A Must)

The outside temperature, wind conditions, pellet fuel variety and the altitude at which you live affect grill temperatures. The hood thermometer is only an approximate temperature and should be used as a guide only. The best way to ensure your meat has come up to the proper temperature and is ready to eat is to use a meat thermometer. Purchase a good quality **instant read meat thermometer**, remembering that these are to be left in the meat for one minute, not the entire cooking time. To use, plunge the thermometer into the thickest part of the meat, making sure the tip is not touching a bone. A long-handled, long-needled thermometer is useful for large cuts of meat and poultry. Instant-read thermometers also are available in digital models, some even with a wireless, remote readout.

Tongs

Use tongs rather than a fork for turning and handling meats to avoid losing the natural juices. Extra large ones allow you to grip a variety of delicate foods and extra long handles

Basting Brush

You may need a selection of these, because you should not use the same brush in two different marinades. Used to apply your favourite sauces and marinades to foods on the grill. Again look for one with a long handle, to keep your hands away from the heat. Natural bristles that are cut at a 45° angle make it easier to baste large cuts of meat.

Spatulas / Turner

A most for turning those delicious burgers and fish filets. Again as with any grilling tools look for a long, sturdy handle and the widest blade possible. The holes in the blade prevent the build-up of steam, which could make your food soggy.

Timer

Using a timer

Aluminum

Extra-strength
into a flat di
speed up coo
large piece

Drip / Rack

Used to pre
juices that c
be added to
etc.

Grill Basket

Perfect for c
certain cuts
halves being
also allows

Griddle

One of the m
to griddle co
outdoors, an

Cooking Plate

Nickel-plat
can be used
flavoured ai
capacity of

Skewers

Wood skew
remember t
heat of the
Metal skew
food from r
are ideal wa

Metal Brush

It is importa
the best too

Skillets

These bask
food the sa
reach the f



GRILLING TIPS AND TECHNIQUES

HELPFUL HINTS

Before preheating the grill, make sure it is safe, clean and hygienic.

Wipe off all stainless steel surfaces before preheating. Dirt and food stains will cook into the surface.

Ensure the ash/drip pan is clean and free from any debris and fat build-up.

Always check your pellet fuel hopper for debris and to ensure that you do not run out of pellets before finishing.

Always preheat your grill before cooking. After ignition has taken place turn your control knob to the PREHEAT setting, be sure the lid is closed and allow the grill to heat for at least 10 – 15 minutes or until the thermometer registers over 500° F.

To prevent foods from sticking, you can brush or rub cooking oil on the cast iron grills. If using a vegetable spray use it only before lighting the burn pot. Never spray the grill while there is fire in the burn pot.

Sear meats and cook with the lid down for perfectly grill food every time.

All Louisiana Grills are designed to allow even fan forced heat circulation, so foods cook evenly on all sides. Leave at least 1" of clearance between the food and the hood for proper heat flow.

Grilling times in recipes are based on 70°F (20°C) weather and little to no wind. Allow more time on cold, windy days, or even for higher altitudes. Allow less time for warmer weather.

Grilling times in charts and recipes are approximate.

Large or thicker pieces of meat will require more cooking time per pound than smaller or thinner pieces.

Foods on a crowded cooking grate will require more cooking time than just a few foods.

Foods grilled in containers, such as baked beans, will require more time if grilled in a deep casserole rather than a shallow baking pan.

Use long-handled tongs for turning all meats and spatulas for turning burgers and fish. Do not use a fork for turning, as it will pierce the meat allowing the flavourful juices to escape.

Determine the doneness of meats by making a small slit near the bone and checking the colour. For boneless cuts, make a slit near the centre. For thicker cuts or larger pieces of meat and poultry insert an instant-read thermometer into the centre of the largest muscle of meat or in the inner thigh or breast of poultry. Charring meat, poultry or fish is not recommended.

When grilling any meats, poultry or any food remember moisture retention is a must: sear the outside first to lock in juices; add salt, if needed, after cooking; flip cuts of meat when bubbles start to appear so the moisture goes back into the meat; sauces are best applied near the end of cooking to prevent burning; and always use tongs, not a fork.



We want yo
hygiene:

Food Ha

Wash hand
fresh meat,

Use a differ
raw meat o

Use a differ

Keep hot fo

Do not leav

Cooked foo
casserole d

Do not defro

Marinate m
moist foods

A marinade
meat, be su

Always use

It's a good i
from resting
surface by h

COOKING FOR A CROWD

TIP

*The number one rule for cooking for a crowd is **PLANNING!** The second would be to use only tried and proven recipes. Grilling should be fun and stress free leave new recipes for your everyday cooking.*

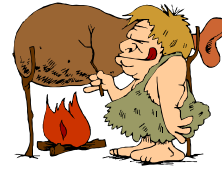

Planning includes not only a menu, but also the complete party. Chairs, tables, dishes, utensils, entertainment, and planned or unplanned weather conditions. Rented beverage coolers, extra table and chairs, or maybe even a tent may be added conveniences to consider.

Select menu items that can be completely or partially prepared in advance – salads, condiments, casseroles, breads, baked goods, and smoked meats. Try smoking a turkey the day before for big event. A turkey will pick up more of the smoke flavour after setting in the refrigerator over night and because of the convection cooking of your grill the meat will be just as juicy as if done straight of the grill.

Grill “time proven” classics such as burgers, chicken pieces, hot dogs or sausages – all great tasting and easy to grill.

Make a list of every food item you will be serving so that nothing will be forgotten in the rush.

Working backward from a planned serving time, decide when to start cooking each food so that everything is ready at the right time. Make a schedule for cooking foods on the grill, plus any indoor cooking.

Plan a serving dish and utensil for each food and have those items. Heavy-duty paper plates come in many attractive colors and patterns and will save dishwashing later. Paper or plastic beverage cups are a must if having any little ones, or young at heart, around.

TIP

To cut down on dishwashing and using every cup in your cupboard, purchase plastic or styro-foam cups. Have your quests create their own personalized decorated cup using markers, crayons and a little creativity.

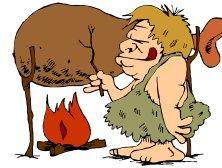

Grill the meat or entrée at the specific recipe temperature, making adjustments with vegetables, side dishes and breads if necessary.

Better yet, let everyone lend a hand, bring a favorite side dish, serve buffet, and have a great time at your own party!

