



# Cookbook and Owner's Guide



Kentwood

Greenwood

Little Louie

**You must read this Owner's Guide before operating your grill**



Toll Free 1-877-303-3134  
www.dansons.com

- Mesquite
- Hickory
- Apple
- Alder



Dear "Louisiana Grill" Wood Pellet Barbecue Owner:

Thank you for choosing to purchase a "Louisiana Grill" wood pellet or dual fuel barbecue. Please accept our gift of a 20lb. bag of flavored wood pellets as both a "Thank You" and as a start to get you on the road to the savory flavor of convective wood pellet cooking.

Cooking with your Louisiana Wood Pellet Grill is about to bring you full circle from the days of the caveman when cooking outdoors and with wood was a necessity, to cooking indoors in your modern kitchen and now back to the great outdoors and that savory wood flavor.

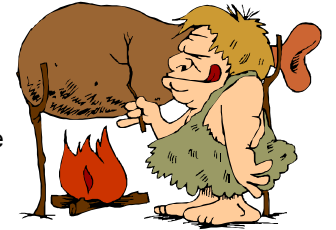

Think of your "Louisiana Grill" as an extra stove available to bake, roast, grill, sear and smoke food. Barbecuing provides a form of entertainment, which is relaxed and casual. Your meals can be completely cooked outdoors and where the chief is one of the crowd.

We'd like to take this opportunity to pass on a few **important tips** concerning grilling with wood pellets.

1. **Initial set-up of our "Louisiana Grill" is the most important step** to ensure the efficient and satisfactory operation of your barbecue for many years to come.
2. **Be diligent in your cleaning and maintenance program. Taking care of your grill will add years of life and keeps it looking great.**

Our loyal staff, valued customers, friends and our loving families have all contributed recipes to this cookbook. We have tried to include a broad range of cuisines and styles, starting with Mom's Great Home Cooking and many, many, catering and entertaining experiences to current classics and new soon to be classics.

If you are interested in contributing a family favourite, please send it by:  
Fax: 1-780-960-0430, Web [www.dansons.com](http://www.dansons.com), or to the address below.

With a minimum of care your "Louisiana Grill" stove will provide years of clean, efficient and environmentally sound cooking. And be prepared for those never ending compliments. Thank you for choosing "Louisiana Grill".

Canadian Comfort Industries &  
Dansons Group Inc.

### COPYRIGHT NOTICE

Copyright 2003, **Canadian Comfort Industries**. All rights reserved.  
No part of this manual may be copied, transmitted, transcribed, stored in a retrieval system, in any form or by any means without the expressed written permission of,

**Canadian Comfort Industries; 26319 Twp Rd 53, Acheson, AB, Canada T7X 5A3**

## DANGERS & WARNINGS

Failure to follow the Dangers, Warnings and Cautions contained in this Owner's Manual may result in serious bodily injury or death, or in a fire or an explosion causing damage to property.



Do not store a spare or disconnected liquid propane cylinder under or near this barbecue.

After a period of storage, and/or non-use, the Louisiana Grill Barbecue should be checked for burner obstructions before use. See instructions in this manual for correct procedures.

Do not operate the Louisiana Grill barbecue if there is a gas leak.

Do not put a barbecue cover or anything flammable on, or in the storage area under the barbecue.

Children should never use your Louisiana Grill barbecue. Accessible parts of the barbecue may be very hot. Keep young children away while it is use.

You should exercise reasonable care when operating your Louisiana Grill barbecue. It will be hot during cooking or cleaning and should never be left unattended or moved while in operation.

Do not use lava or charcoal in your Louisiana Grill.

Never lean over open grill or place hands or fingers on the front edge of the cooking box.

Should a grease fire occur, turn off all burners and leave lid closed until the fire is out.

Do not enlarge valve orifices or burner pots when cleaning the valves or burners " Louisiana Grills " should be cleaned on a regular basis.

Use heat-resistant barbecue mitts or gloves when operating barbecue.

#### **LIQUID PROPANE GAS UNITS/SIDE BURNERS ONLY:**

Use the regulator that is supplied with your Louisiana Grill Dual Fuel barbecue.

Liquid propane is not natural gas. The conversion or attempted use of natural gas in a liquid propane unit will void your warranty.

Should the propane burners go out while in operation, turn off all gas valves. Open the lid and wait five minutes before attempting to relight, using the lighting instructions

Do not attempt to disconnect any gas fitting while your barbecue is in operation.

A dented or rusty liquid propane cylinder may be hazardous and should be checked by your liquid propane supplier. Do not use a liquid propane cylinder with a damaged valve.

Although your liquid propane cylinder may appear to be empty, gas may still be present, and the cylinder should be transported and stored accordingly.

If you see, smell or hear the hiss or escaping of gas from the liquid propane cylinder:

Move away from the cylinder.

Do not attempt to correct it yourself.

Call your fire department

## **CONTENTS**

<b>HOW YOUR LOUISIANA GRILL WORKS</b>	<b>5</b>
<b>LITTLE LOUIE / KENTWOOD GRILLS</b>	<b>6</b>
<b>GREENWOOD / GRANDE ISLE GRILLS</b>	<b>7</b>
<b>SPECIAL FEATURES</b>	

<b>STAINLESS STEEL "FLAVOR GUARD"</b>	<b>8</b>
<b>STAINLESS STEEL FLAME DEFLECTOR</b>	<b>8</b>
<b>STAINLESS STEEL BURN POT</b>	<b>8</b>
<b>CONTROL PANEL</b>	<b>8</b>
<b>CAST IRON COOKING GRILL</b>	<b>9</b>
<b>"GRILLMATE" COOKING GRATE</b>	<b>10,11</b>
<b>COVER-UP</b>	<b>12</b>
<b>ABOUT WOOD PELLETS</b>	<b>13</b>
<b>OPERATION</b>	
<b>UNPACKING YOUR GRILL</b>	<b>14</b>
<b>INSTALLING THE SIDE SHELVES</b>	<b>14</b>
<b>INITIAL SET-UP</b>	<b>15</b>
<b>GETTING STARTED</b>	<b>16,17</b>
<b>LIGHTING – AUTOMATIC</b>	<b>18</b>
<b>LIGHTING – MANUAL</b>	<b>19</b>
<b>SMOKE MODE</b>	<b>20</b>
<b>SHUTTING OFF</b>	<b>20</b>
<b>GRILL MAINTENANCE</b>	<b>21</b>
<b>LIMITED WARRANTY</b>	<b>22,23</b>

#### **COOKBOOK**

<b>GRILLING TIPS AND TECHNIQUES</b>	
<b>COLD WEATHER COOKING</b>	<b>24</b>
<b>HOT WEATHER COOKING</b>	<b>24</b>

#### **FOOD SAFETY TIPS AND TECHNIQUES**

## **HOW YOUR LOUISIANA GRILL WORKS 101**

Your Louisiana Wood Pellet Grill combines many unique features with time proven pellet-burning technology. Together they give you perfect control, quick, savoury-and absolutely fool proof cooking results every time.

The perfect barbecue experience starts with filling your hopper with all natural wood pellets. Pushing the Start Button activates the "Electronic Auto Igniter", the combustion fan, and the auger feed systems.

The auger delivers the pellets to the burn grate. Your **Louisiana Grill** uses "Top Feed" technology which means the auger pushes the wood pellets up above the burn pot area and then the pellets fall down a chute in to the burn area. The top of the auger is an open design, thus reducing the possibilities of "auger jams" and allows for the use of less than premium fuel quality. Adjusting the temperature control switch sets the speed of the auger and the temperature output. The "Electronic Auto Igniter" activates for approximately 30 minutes, or until an operating temperature of 120° F is reached, igniting the pellets in the burn pot. A fan provides combustion air to the burn grate as well as causes air movement in the cooking area, resulting in convection cooking. The fuel burns in the burn grate, hot and intense, somewhat like a forge. The fly ash is directed downward by the "Flame Deflector", and can be cleaned out through the ash drawer. The "Flame Deflector" also protects the food from direct flame and distributes the heat evenly throughout the cooking area. The natural smoke flavour produced by the burning pellets, the smoke produced by the "Grillmate" or "Flavor Guard", and the air circulating throughout the cooking area, combine to give you that savoury flavour that is unique to pellet grills and will win you rave reviews each time you use it.

**Tip**

Your Louisiana Grill can run efficiently over extended periods of time and at different heat output levels as long as the fuel supply is uninterrupted and *timely cleaning and maintenance is performed.*

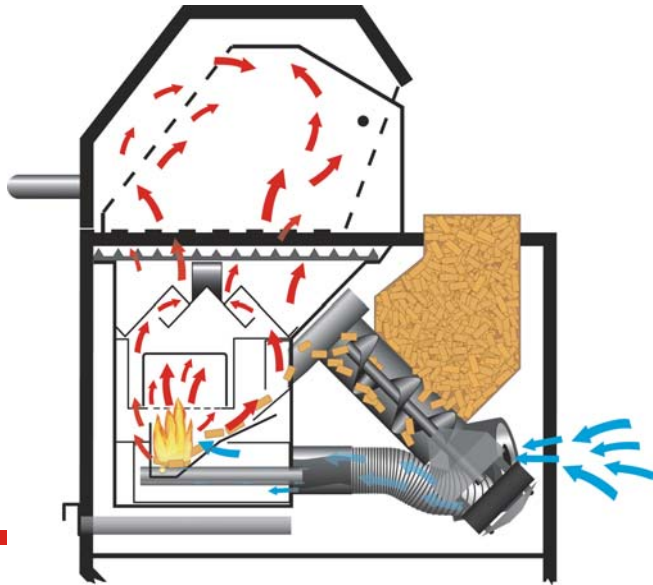
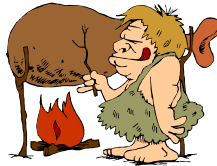

**YOUR**

**"LITTLE LOUIE" OR "KENTWOOD" CART PELLET BARBECUE . . .**

**NEW**



	Heat Output	Cooking Area	Electric	Size H x W x D
Little Louie	approx. 26,000 BTU's	200 sq. Inches Large enough to cook a 25lb. turkey	110 Volt 3 prong plug	46" x 40" x 25"
Kentwood	approx. 45,000 BTU's	408 sq. Inches Large enough for the whole family	110 Volt 3 prong plug	48" x 46" x 30"

**Options:**

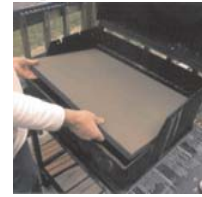

**1 pc Cabinet Door**  
Stainless Steel or Black Paint Grade

Reduces flare-ups  
Prevents grease corrosion  
Improves heat distribution



**Grillmate™** (Standard on Kentwood Stainless Steel models)

**Custom Fit Grill Cover**  
Stylish vinyl cover to protect your investment

## YOUR NEW "GREENWOOD" OR "GRAND ISLE" CABINET PELLET GRILL ...



High quality thermostat

Cast iron grills for long life and even heat distribution

Low CFM Blower Fan Causes pellets to burn and ConvectionOven cooking

Auto Start Button & Electric Igniter eliminate the need for matches & lighter fluids

Full Range Temperature Control gives range of 200 to 600 deg F, giving more cooking options

Smoke Switch gives you that savory flavor on demand Hot smokes at approximately 200 deg F.

Available in paint grade or all stainless steel finishes

Stainless Stay Cool Handle

Double wall construction helps retain heat for all year grilling

Large 10 lb.+ Hopper capacity Sealed, easy to flip up top (Located on backside of unit)

1 pc "Grill Mate" stainless steel and platinum coated cooking grate Enhances quality and quantity of smoke. Reduces flare-ups and improves heat response and distribution

Stainless Steel Wrap-around Shelf offers a durable easy to clean surface

Ash Drawer and Grease Catcher, makes for no fuss cleaning (located behind the cabinet doors)

Enclosed cabinet area Large protected storage

Heavy duty construction using stainless & aluminized steel

Large easy-roll wheels

Heavy duty locking casters

	Heat Output	Cooking Area	Electric	Size H x W x D
Greenwood	approx. 45,000 BTU's	408 sq. Inches Large enough to entertain	110 Volt 3 prong plug	48" x 47" x 35"
Grand Isle	approx. 50,000 BTU's	612 sq. Inches Large enough for family and friends	110 Volt 3 prong plug	48" x 57" x 35"

### Options:



Reduces flare-ups  
Prevents grease corrosion  
Improves heat distribution

**Grillmate**  
(Standard on Stainless Steel models)



**Custom Fit Grill Cover**  
Stylish vinyl cover to protect your investment



## STAINLESS STEEL "FLAVOR GUARD" GRATE

Your "Little Louie" or select "Kentwood" Louisiana Grill is equipped with a high temperature stainless steel "Flavor Guard" grate. This grate like device is installed above the burn pot and flame deflector, and is used to catch and vaporize the cooking juices. The "Flavor Guard" is constructed of five offset "V" shaped runners welded together to make a single piece. There are also two moveable pull-tabs installed to make removal easier. When properly installed, the pointed top of the "V" shaped runners and the two pull-tabs must point upward toward the cast iron cooking grills.

When the meat juices drip from the food onto the specially angled "Flavor Guard", it creates the smoke that gives food that irresistible barbecued flavour. Thanks to the unique design of the "Flavor Guard" and the flexible temperature controls, uncontrolled flare-ups are virtually eliminated, because you control the flames. There is no lava rock or brick to absorb excess fat drippings that can cause unwanted flare-ups. The "Flavor Guard" is rust resistant and easy to remove and clean.

## FLAME DEFLECTOR

All "Louisiana Grill" models come with a stainless steel flame deflector and burn pot, designed to withstand high temperature and give years of performance. The flame deflector has been designed to keep the flame out of direct contact with your cooking surface, thus helping to reduce the chance of flare-ups. As well you will note the notches in the side of the deflectors; these are to help in distributing the heat evenly throughout the whole cooking area and right to the edges. The unique design of the deflector also directs the majority of fly ash down toward the ash pan,

## BURN POT

The burn pot is also constructed out of stainless steel and is the heart of your grill. The burning temperature in the pot can reach temperatures of 1700 to 2000°F. The air holes are designed to allow the right combination of fan forced air to force the wood pellets to burn hot and clean while grilling or allow them to smoulder and produce the savory smoke while in the smoke mode. The bottom is notched out to allow the pot to set over the electric igniter, allowing the heated air within the ignitor casing to heat up the pellets until they spontaneously combust.

## CONTROL PANEL

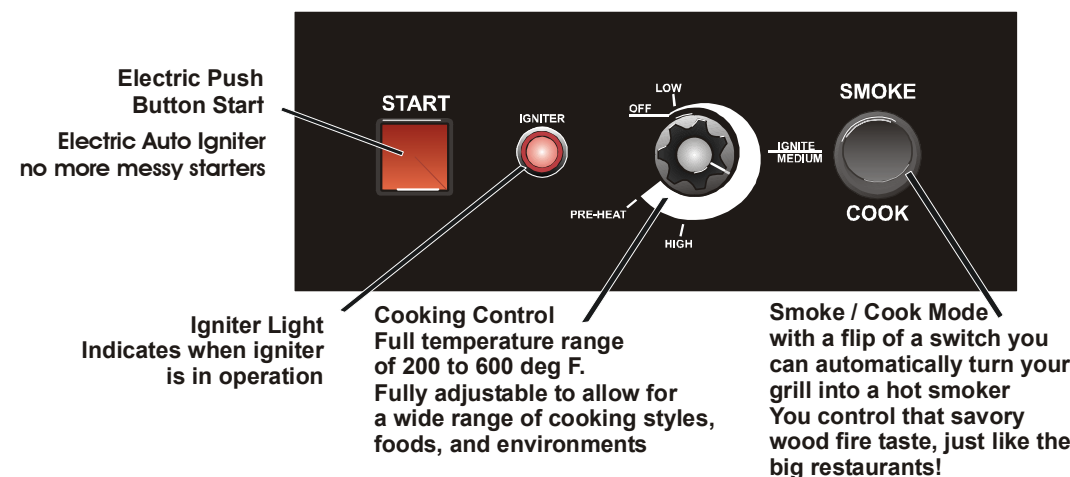

Electric Push Button Start  
Electric Auto Igniter  
no more messy starters

Igniter Light  
Indicates when igniter is in operation

Cooking Control  
Full temperature range of 200 to 600 deg F.  
Fully adjustable to allow for a wide range of cooking styles, foods, and environments

Smoke / Cook Mode  
with a flip of a switch you can automatically turn your grill into a hot smoker  
You control that savory wood fire taste, just like the big restaurants!



## CAST IRON COOKING GRILLS

Your Louisiana Grill comes complete with cast iron cooking grills. To maintain the excellent searing and grilling performance of your grills, as well as their longevity, some special care and maintenance is required. As with any cast iron cooking tools, PROPER SEASONING is a must.

### First time use

Before using any cast iron grill, wash it thoroughly with a mild dishwashing liquid to move the protective wax coating applied for shipping. Rinse with HOT water and dry completely with a soft cloth or paper towel. NEVER WASH IN A DISHWASHER, OR ALLOW THEM TO DRAIN DRY. Now you must season the grills to prevent rust and sticking.

### How to “Season”

A solid vegetable shortening or olive oil is recommended for the initial seasoning.

1. Spread a thin coating of solid vegetable shortening or olive oil over the entire surface, including all corners, with a paper towel. Do not use salted fats such as butter or margarine.
2. Preheat your Louisiana Grill for 15 minutes then place the coated grills in the barbecue.
3. Turn your heat setting to medium/ignite and close the lid.
4. Allow your Louisiana Grill to heat the cast iron grills for 1 to 1 ½ hours.
5. Turn off the Feed Rate/Temperature control and let your Louisiana Grill go through the SHUT DOWN cycle and cool completely.
6. Your cast iron grills are now “Seasoned” and ready for use.

### Maintenance (every time you grill)

DO NOT do a prolong burn-off after you grill. Approximately 5 minutes will do, as this burn-off is required to help in the maintenance of the “Grillmate” cooking grates (not available on all models) Leaving the cooking residues on the cast iron grills does leave a protective coating on the iron. Then do a burn-off or a 10 – 15 minute preheat just before your next cook out. This will vaporize most everything on the grill, then brush off charred residues with a steel brush rather than a brass brush.

### Rust

If rust does appear, it is an indication that the cast iron grills have not been seasoned properly or enough. Or, if the extended burn-off method has been used after grilling, the seasoning has also been burned off. You must begin the seasoning process again, after brushing all rust away with a steel wire brush

#### TIP

The more you use your Louisiana Grill and the cast iron grills, the easier the maintenance will be. If you store your cast iron grills for extended periods of time, grease them very lightly with vegetable shortening or olive oil, then wipe them dry with a paper towel. Store them in a dry place.

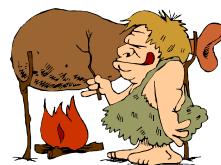

## “GRILL MATE” COOKING GRATE

Select Louisiana Grills come complete with this unique stainless steel structure called “Grill Mate”, manufactured for us by Chef Tech LLC. This cooking grate delivers the ultimate control in cooking with either wood pellet or liquid propane. There are no lava rocks, bricks, or other material to absorb excess fat drippings that can cause unwanted flare-ups. Thanks to the unique design of “Grill Mate” and the flexible temperature control, uncontrolled flare-ups are virtually eliminated, because YOU control the flames.

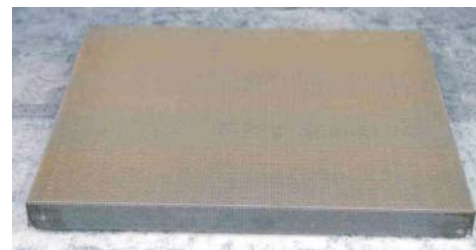

“Grillmate”



Bottom surface

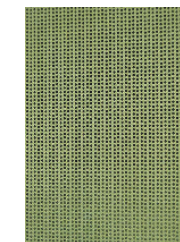

Top Surface

### Frequently Asked Questions:

#### What is the “Grillmate” and what does it do?

The “Grillmate” is a unique stainless steel structure, which is coated with a specially designed catalyst, platinum. This structure intercepts the grease and other drippings from the food being grilled before it can reach the hot metal surfaces and burner pots below and result in a flare-up. The catalyst allows the unit to burn the grease at a lower temperature and thus generates smoke instead of flame.

#### What are the benefits of the “Grillmate”?

1. **Eliminates flare-ups.** When properly installed and maintained, the unit will virtually eliminate flare-ups.
2. **Enhances the amount and quantity of smoke.** The “Grillmate” creates smoke from the natural juices of the food being grilled. This results in that “smoked and savory” flavor.
3. **Prevents food from drying out.** Because the “Grillmate” eliminates flames and generates smoke and steam from the natural juices, the food does not dry out.
4. **Improves heat distribution.** The “Grillmate” is designed to distribute the heat output of the burner or burners, by evenly distributing the heat produced from the burn pot.
5. **Improves heat response.** The stainless steel construction of the “Grillmate” does not store excess heat; therefore, when the burner temperature is adjusted, the temperature at the grilling surface changes very quickly (usually within 90 seconds). This enhances your ability to sear the food then reduce the heat and grill it over a low heat.
6. **Increases the life of the grill.** The “Grillmate” reduces the amount of grease that reaches the burners and surrounding area by up to 75%. Grease and drippings are the primary reason for corrosion of the gas burners and grill body.

#### Do I need to Parboil really fatty foods?

No, simply put them on the grill and go! The “Grillmate” is specially designed to eliminate flare-ups so that no extra effort is required when cooking foods like bratwurst, Italian sausages, chicken legs and backs, or spare ribs. Just remember to grill on a lower setting.



## “GRILL MATE” COOKING GRATE

### Operation:

1. Follow the instructions for lighting your Louisiana Grill. (see details elsewhere in this manual).
  2. Allow the grill to preheat for 10 minutes.
  3. Grill as you normally would. You will notice an increased amount of smoke, which adds that “smoked and savory” flavor to your food.
  4. If you notice any grease, which ignites on the cooking grate, turn the temperature down in order to achieve maximum performance.
- Note:** because of the nature of the “Grillmate” cooking grate, low temperature settings will cook as quickly and thoroughly as high one’s, in turn, greatly reducing your operating costs.
5. After grilling you should allow the unit to clean itself. (see details in the following section).



### Use and Care

Your “Grillmate” cooking grate will give you many years of flavourful service, however, you should read and observe the following precautions:

The “Grillmate” is a self-cleaning structure and requires only a 15-minute cleaning cycle on the high setting. We normally would recommend this after each grilling. However, many users who grill frequently have found that this can lead to excessive fuel consumption, and is not recommended because of the cast iron grills. We have developed the following cleaning procedure, which works well, but depending on your grilling habits, may result in reduced performance.

#### *Normal Cleaning Method:*

After the completion of grilling, turn the grill to high until only an occasional wisp of smoke is seen (about 5 minutes). This will remove most of the material that builds up on the “Grillmate”. The next time you grill allow the grill to preheat on high for 5 – 10 minutes to complete the cleaning cycle.

#### *Periodic Thorough Cleaning Method:*

At least once every 5 to 6 uses (more if you experience heavy build-up & less if you do not) you should perform a complete cleaning cycle. This consists of turning the grill on high for a 15 – 20 minute period. Allow the grill to cool completely, remove the cast iron grill(s) and brush the Grill Mate with a soft bristled brush (paintbrush or old BBQ brush). **DO NOT USE A STIFF OR WIRE BRISTLED BRUSH OR CLEANING SOLUTIONS. THE USE OF THESE ITEMS WILL VOID THE WARRANTY ON YOUR GRILL MATE.**

#### *Alternate Cleaning Methods:*

1. The “Grillmate” may be placed in your self-cleaning oven and subjected to a “clean” cycle.
2. The “Grillmate” may be gently rinsed with a garden hose. If you have hard or chlorinated water, you should rinse the “Grillmate” with distilled water prior to reinstalling in the grill.



## COVER-UP

Your Louisiana Grill cover will help in protecting your grill from the detrimental effects of weather and outside pollutants. As with any outdoor product, however, a cover is only as good as the maintenance given to the grill. Following the recommended maintenance included in this manual will add greatly to the life of your grill.

“Louisiana Grills” covers carry a limited 2-year warranty from the manufacturer against splitting or cracking, but there are some common sense precautions that you should take in caring for the vinyl covers.

### Helpful Hints

#### **DO's**

Keep your Louisiana Grill cover clean. This is your best protection against mildew which will form on any dirt or foreign material allowed to accumulate on tops or bottoms of fabric. Use a cleaner such as Armor-All, or a product that will not only clean but also protect.

Have any small tears or punctures repaired promptly.

Keep away from pets.

Keep all shrubs and vines away from your grill cover as many plants contain acids, which harm fabrics.

#### **DO NOT**

Cover your grill while the grill is still hot

Store anything on the top of your grill cover.

Permit leaves, twigs or other organic debris to remain on the cover for long periods of time

Use high-pressure hoses or steam to clean.

Use wire or stiff brushes, harsh detergents, abrasive cleaners or chlorine on your grill cover.



## ABOUT WOOD PELLETS

They are no thicker than the eraser on the end of a pencil, people who see them for the first time think they look like rabbit food, but there is nothing small about the heat energy in a wood pellet. These clean burning wood pellets generate about 8200 BTU's per pound with very little ash and low moisture content.

Wood pellets are not new; they have been around for a long time used in industrial, commercial and residential heating appliances. There are more than 125 active pellet mill operations in United States and Canada, producing millions of pounds of pellet each year.

- Mesquite
- Hickory
- Apple
- Alder

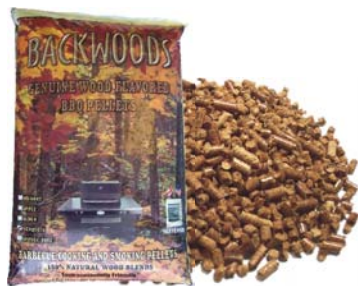

Barbeque wood pellets are produced in the same manner as wood pellet fuel is produced for home heating. Pure raw material (sawdust) is pulverized with a hammer mill and then dried. The dried material is then processed under heat and pressure. Lignin, which is the natural glue, which holds plant fibre together, softens above 100° C, permitting the material to change shape. The hot lignin then acts like a binding agent to bond the pellet together. The heated material then goes through a hard steel die, much like a meat grinder,

which rotates against rollers forcing the material through the die with pressure over 3 000 PSI. As the pellet is forced through the die it is sheared off at a specific maximum length, cooled, screened, vacuumed, and then bagged into 20 lb bags.

General specifications for barbeque pellets are: 100% hardwood, 1" long or less in length, ¼" diameter, less than 2% ash content, less than 2% fines, under 10% moisture content, approx. 8200 BTU's per lb. and about 40 lbs per cubic ft. density.

Mesquite, from the Aztex "mizquiti" (which means "the honey tree"); true to its name gives a delicate, subtle, sweet flavour to grilled foods- especially good with poultry and seafood.

Hickory intensifies the flavour of food with a robust, tangy taste that is better suited to red meat than to poultry and fish.

Apple or fruitwoods, many from orchards destroyed by fire or old age, are a big hit. Like its mesquite counterpart, the heaviest branches of the apple tree is heated to kill insects, then chipped, made into pellets, and packaged for retail. Apple or any fruitwood, adds a smoky, mild sweetness to everything that you cook or is highly recommended for any baking.

	Beef	Buffalo	Chicken	Turkey	Fish	Lamb	Pork	Baking
Alder	x	X	x	x	X	x	X	X
Apple			x	x			X	X
Hickory	x	X	x	x			X	
Mesquite	x	X	x	x	X			



## UNPACKING YOUR LOUISIANA GRILL

Your new Louisiana Grill "Little Louie" or "Kentwood" model does require some assembly. Please note that during shipping some movement may have taken place, so a complete visual inspection is required.

### TIP

Be sure to inspect entire grill after removing the protective shipping carton. Report any damage to your local dealer immediately. Shipping damage is not covered under warranty.

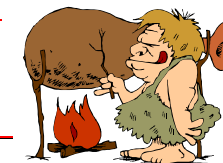

### Tool Required:

1 - Phillips Screwdriver

### Procedure:

Open the cabinet doors. You will find 2, 3" long Phillips wood screws inside securing the grill to the shipping crate. Back these out. Check to ensure the "Stops" on the casters have been disengaged. Gently remove your grill from the shipping pellet and roll into place.

## INSTALLING THE SIDE SHELVES

### ATTENTION:

Care must be taken not to cross thread the mountings screws into the brass nut inserts

### Tool Required:

1 - Phillips Screwdriver

### Unpack & identify pieces.

1. 1 left hand side support bracket. (this has the control board installed.)
2. 1 right hand side support bracket.
3. 2 Stainless Steel side shelf tops.
4. 12 Stainless Steel #8/32 x 5/8" long screws

### Procedure:

Install the right hand side shelf support. You will use 4 stainless steel screws.

The best way to ensure that you do not cross thread the brass nut inserts is to start each screw by hand. Hand tighten each screw, and then tighten to a snug fit using the Phillips screwdriver.

Install the right hand stainless steel top shelf. You will use 2 of the #8/32 x 5/8" screws.

Remove the control box, only, from the left hand side support, leaving the wiring harness attached to the support. This now gives you easy access to screw both the support and top shelf to the side of the grill.

Now install the left hand side shelf support using 4 of the stainless steel screws.

Connect the 6 pin wiring harness from the grill to the 6-pin connector leading from the control box. Be sure the connection is tight. Note that the 6-pin connector from the control box has two groves moulded in it, while the other connector has two protrusions moulded to it.

Install the left hand Stainless Steel side shelf top using the final 2 #8/32 x5/8" screws.

Re-install the control box to the side shelf support, using the 2 screws that you removed before.



## INITIAL SET-UP PROCEDURES

Please note that during shipping some movement may have taken place, so a complete visual inspection is required. Please follow these Initial Set-up procedures to insure the proper and safe operation of your grill.

Note: Do not plug your grill into an electrical outlet until this procedure is complete.

**TIP: It is recommended practise to always go through the INITIAL SET UP Procedures after every 5 to 10 uses. This will ensure proper ignition and continuous happy grilling experiences.**

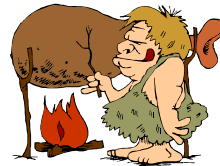

Open the GRILL LID and remove the Cast Iron Cooking Grills. “Little Louie” comes with 1 grill, the “Kentwood” and “Greenwood” models come with 2 sections and the “Grande Isle” comes with 3.

Remove the “Grillmate” or stainless steel “Flavor Guard” Cooking surface.

Remove the Flame Deflector. This is the “U” shaped stainless steel metal piece sitting over the burn grate. The “U” shape sits upside down to help distribute the heat and to keep fly ash to a minimum. The flame deflector also keeps the flame from making direct contact with your cooking.

Remove the stainless steel burn grate and check the burn pot area, remove any foreign items. Ensure that the air holes in the grate are clear of debris.

Re-install the burn grate. Ensure that the stainless steel grate is setting down and snug in the burn pot with the two igniter holes visible and clear of obstructions, in the bottom of the grate. If the grate does not sit firmly in the pot area you will have to adjust the grate adjustment tab.

Re-install the flame deflector. This mounts back on the side brackets located on each side of the burn area. The opening of the “U” shape should be facing downwards, and should be centered over the burn grate.

Re-install the Cooking Grates: For the “Grillmate” ensure that the grill with the small round holes is facing upward and the basket weave pattern is facing downward, towards the flame deflector and burn area. For re-installing the “Flavor Guard”, **the pointed top of the “V” shaped runners and the two pull-tabs must point upward toward the cast iron cooking grills.**

Reinstall the Cast Iron Grills.

Open the Pellet Hopper Lid, found in the rear of your grill, behind the lid. Check for any foreign objects.

Fill the hopper with your choice of wood pellet fuel. Replace the hopper lid.

Plug your Louisiana Grill into the nearest AC outlet.

You are now ready to push that start button and enjoy that savory taste of pellet convection cooking.



## GETTING STARTED

*With today’s lifestyle of striving to eat healthy and nutritious foods, one factor to consider is the importance of reducing fat intake. One of the best ways to cut down on fat in your diet is to use a low fat method of cooking, such as grilling.*

*Throughout this manual, you will notice the emphasis on grilling food slowly at MEDIUM temperature settings. Because of the benefit of convection cooking, and the use of the “Grillmate” or “Flavor Guard”, your Louisiana Grill will enable you to avoid flare-ups and maximize the nutritional value of the foods that you cook.*

### WARNING:

Do not move your Louisiana Grill while operating or while the barbecue is hot. Make sure the fire is completely out and that the grill is completely cold before transporting the grill.

**Following is a list of the important tips that will contribute to the cooking perfection that you can expect when using your Louisiana Grill.**

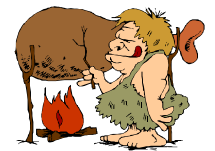

### Operating the Grill

#### Initial Burn Off

Before cooking on your grill for the first time, we recommend that you “burn off” the grill to ride it of any foreign matter. Remove the cast iron grills and wash with a mild soap and detergent. With the grills removed, light and operate the grill on PRE-HEAT with the lid down for 10 – 20 minutes. After burn off, turn the control knob to OFF and replace the seasoned grills.

#### Lighting your Grill

It is recommended practise to always go through the INITIAL SET UP Procedures after every 5 to 10 uses. This will ensure proper ignition and many happy grilling experiences. Light as per instructions found in detail later in this manual. If the grill fails to light, this is most likely due to a dirty or full burn pot blocking the auto igniter air passages. (refer to lighting instructions found elsewhere in this manual)

Should your auto igniter refuse to ignite the wood pellets, it is easy to light your grill manually with a match and lighting agent. (refer to manual lighting instructions found elsewhere in this manual)

#### Pre-Heating

It is extremely important to ALWAYS allow your grill to preheat before cooking. This allows the grill and cast iron grates to heat up quicker and the grill is able to maintain its cooking temperature once your food is put placed in the cooking area. If you do not allow the grill to preheat, you will find that it takes a longer period of time to bring both the grill and the food to cooking temperatures.

Always pre-heat your Louisiana Grill with the lid closed. After your Grill has ignited, set your control knob to PREHEAT for 10-15 minutes depending on weather. This gives you enough time to prepare your food for the grill; as well it is the final step in cleaning your cast iron grates, and the “Grillmate”.

#### Lid Position

**Always cook with the lid closed. Not only does this keep the temperature even, the food will cook faster, using less fuel. A closed lid also helps to create a smokier flavour. You can slow down your cooking by propping up the lid using the grill lifter.**





### Cast Iron Grates

The best chefs use cast iron grills because cast iron heats evenly, and quickly sears food to lock in the juices and natural flavour. Cast Iron is also ideal for great steak house markings. (see Cast Iron Grate Feature elsewhere in this manual).

## Cooking Settings

### Pre Heat

The **PREHEAT** setting will give an oven temperature of over 600°F (316°C), depending on weather conditions. This setting is used to quickly preheat your grill as well as to finish the cleaning cycles for the cast iron grills and the “Grillmate”. Could also be used as a **HIGH** setting in extreme cold weather conditions.

### High

The **HIGH** setting will give an oven temperature of approximately 500°F – 550°F, depending on the weather. This setting is ideal for quickly searing steaks and chops.

### Medium / Ignite

The **MEDIUM / IGNITE** setting will give an oven temperature of approximately 350°F (177°C) when the lid is closed and the weather conditions permit. This setting is recommended for finishing cooking steaks, hamburgers, chops, etc. This setting is also used to **IGNITE** your Louisiana Grill. This setting allows just enough pellets to feed and the proper air to transfer heat from the igniter to start the wood pellet fuel.

### Low

The **LOW** setting will give an approximate oven temperature of 310°F to 350°F (154°C – 177°C).

### Smoke

The **SMOKE** setting will give an approximate oven temperature of 200°F to 220°F. This setting is used to slow roast and to increase the smoke flavour of your favourite food. Highly recommended for that **BIG BIRD** at Christmas, Easter, Thanksgiving, Birthdays, and all other important holidays.

**TIP:** The temperatures listed above are all approximate and will be affected by the outside temperature, the amount of wind present, and the length and type of pellet fuel being used.

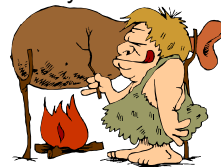

## After Cooking

One of the greatest benefits of your Louisiana Grill is the minimal clean up required. When you are finished cooking and waiting just a little while to let the flavour set in that prime selection of meat, turn the control knob to **PREHEAT** for 5 minutes. Let the grill heat up, then turn the knob all the way counter clockwise, past the **OFF** click and you're **DONE**. A quick wipe up of the stainless steel counter top, using a cloth and mild soap, let the unit cool and put your Louisiana Grill to bed with the optional **GRILL COVER**.

**CAUTION:** Grease fires are caused by not properly maintaining your grill, or failing to clean your clean out drawer on a consistent basis. In the unlikely event you experience a grease fire while cooking, keep the lid closed. If it does not go out in a very short time, open the lid and lightly sprinkle baking soda on the fire. Be careful not to burn yourself. If this does not work, then carefully remove the food from the grates, turn the temperature control to **OFF** and shut the lid until the fire is completely out.



## LIGHTING YOUR LOUISIANA GRILL

**TIP:** It is recommended practise to always go through the **INITIAL SET UP** Procedures after every 5 to 10 uses. This will ensure proper ignition and many happy grilling experiences.

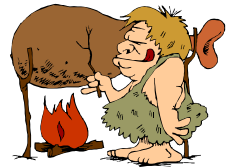

## Automatic Start Up

Place **COOKING MODE SWITCH** to the **COOK** position.

Turn the **FEED CONTROL** (temperature output) to the **IGNITE** position.

Press the **START BUTTON**.

- This initiates the start up cycle, which includes; the auger will start to turn, the igniter will begin to glow, the igniter indicator will light and the combustion fan will start.
- The grill now has 30 minutes to produce heat before it will shut down automatically.
- The igniter and igniter indicator will turn off automatically when you're the temperature sensor switch reaches 120°F or 30 minutes.

Your grill will begin to produce smoke while the start up cycle is taking place. Close the lid.

The grill is operational once the smoke is cleared. To check open the lid of your grill and a flame will be visible in the burn pot area. You will be able to view this without having to touch any hot surfaces.

Turn the **FUEL FEED** to **PREHEAT** and allow unit to preheat for approximately 10 minutes.

**CAUTION:** If excessive flame is visible i.e. **FLAME DEFLECTOR** is glowing bright red, turn the **FEED CONTROL** down.

After the pre-heating is complete you are now ready to enjoy your grilling experience

**NOTE:** Different wood pellets will produce different temperatures; as well the outside temperature and weather conditions will also affect your cooking temperature. The markings on the **CONTROL LABEL** are approximate.

**NEVER** add pellets by hand to a hot fire pot. This is dangerous and you may get seriously burned. If you do run out of fuel and you lose your fire while cooking, open the lid, turn off all controls, and let the unit completely cool. The grill will go through its **SHUT DOWN** cycle automatically. Once the **SHUT DOWN** cycle is complete. re-fill the hopper and go through the normal **LIGHTING** procedure.

**NOTE:** If the fire does not start, the Grill will continue to feed pellets and the fan will run for approximately 30 minutes. The grill will then automatically shut off. If this happens, some unburned pellets will build up in the burn grate. To restart the fire, clean the excess pellets out of the burn grate and follow the above steps.



## Manual Start Up

If for any reason your electric igniter fails, you can start your “Louisiana Grill” manually.

Remove the cast iron grills, and the “Grillmate” or “Flavor Guard”. You will also have to remove the Stainless Steel flame deflector.

Inspect the stainless steel burn pot to ensure that is clean of debris and that the ignitor air holes are not obstructed. Also check to ensure proper placement of the burn grate.

Place a small handful of pellets in the bottom of the burn grate.

Add a small amount of solid fuel fire starter, such as those made from sawdust and wax or use wood shavings. Add a small amount of pellets over the fire starter.

**CAUTION: DO NOT USE ANY FLAMMABLE LIQUIDS SUCH A GASOLINE, GASOLINE-TYPE LANTERN FUEL, KEROSENE, CHARCOAL LIGHTER FLUID, OR SIMILAR LIQUIDS TO START OR FRESHEN-UP THE FIRE! KEEP ALL SUCH LIQUIDS WELL AWAY FROM THE GRILL WHILE IT IS IN USE.**

Light the fire starter.

Place **COOKING MODE SWITCH** to the **COOK** position.

Turn the **FEED CONTROL** (temperature output) to the **IGNITE** position.

Press the **START BUTTON**.

- This initiates the start up cycle, which includes; the auger will start to turn, the ignitor indicator will light and the combustion fan will start.
- The grill now has 30 minutes to produce heat before it will shut down automatically.
- The ignitor indicator will turn off automatically when you're the temperature sensor switch reaches 120°F or 30 minutes.

Quickly and carefully, replace the stainless steel flame deflector, the “Grillmate” or “Flavor Enhancer” and the cast iron cooking grills. Your grill will begin to produce smoke while the start up cycle is taking place. Close the lid.

The grill is operational once the smoke as cleared. To check open the lid of your grill and a flame reflection will be visible in the burn pot area. You will be able to view this without having to touch any hot surfaces.

Turn the **FUEL FEED** to **PREHEAT** and allow unit to preheat at 500 to 600°F for approximately 10 minutes.

**CAUTION:** If excessive flame is visible i.e. **FLAME DEFLECTOR** is glowing bright red, turn the **FEED CONTROL** down.

**NOTE:** If the fire does not start, the Grill will continue to feed pellets and the fan will run for approximately 30 minutes. The grill will then automatically shut off. If this happens, some unburned pellets will build up in the burn grate. To restart the fire, clean the excess pellets out of the burn grate and follow the above steps.



## SMOKE MODE

Smoking is a variation on true barbecuing and is truly the main advantage of grilling on a wood pellet grill. There are two types of smoking: **HOT** smoking and **COLD** smoking. **HOT** smoking, just another name for barbecuing, is generally done at 200 to 250°F. **COLD** smoking is where the food is located so far away from the fire that it smokes without cooking. Your “Louisiana Grill” is classified as a **HOT** smoker.

**TIP:** To intensive that savory smoke flavor, switch to smoke mode immediately after putting your food on the grill. This allows the smoke to penetrate the meats before they have a chance to sear closed.

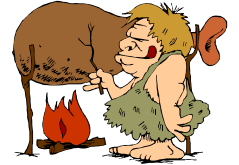

The smoke mode works best when a longer cooking time is required, such as large cuts of meat, fish, or poultry, Experiment with the length of time you leave for smoking, before cooking thoroughly. Try different combinations of both modes. Some chefs prefer the smoke mode at the end of cooking and to keep the food warm until ready for serving. Remember practice makes perfect.

### TO ACTIVATE

Follow the standard **LIGHTING PROCEDURES**.

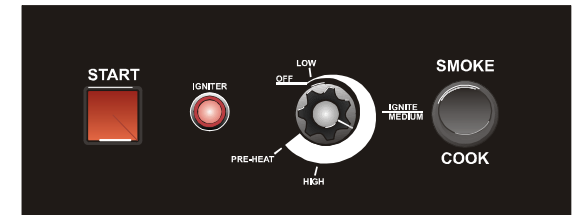

After the start up cycle is complete, and you have gone through the preheat cycle, activate the smoke mode by clicking the **COOKING MODE SWITCH** to the **SMOKE** position. The **SMOKE** control switch will always override the normal **FEED CONTROL**.

When finished using the smoking mode click the **COOKING MODE SWITCH** back to the **COOK** mode.

### SHUTTING OFF YOUR LOUISIANA GRILL

Your “Louisiana Grill” , “Grill Mate” and the “Flavor Guard” cooking grids will give you many years of flavourful service with minimum cleaning. An important step is allowing the grill and cooking grates to “Self Clean” by running the grill on high temperature for 5 – 10 minutes after each use.

Deactivate the **SMOKE** mode by switching the **COOKING MODE SWITCH** back to **COOK** mode.

When finished cooking on your Louisiana Grill turn the **FEED CONTROL** switch to the high position. Let your grill run for 5 – 10 minutes to go through its normal cleaning method.

When complete, rotate the **FEED CONTROL** (temperature) switch fully counter-clockwise. You will hear it click at the off position.

Once the **FEED CONTROL** is in the **OFF** position, your Louisiana Grill will start it's **SHUT DOWN** cycle. The **AUGER** will stop feeding fuel, the flame will burn itself out, and the combustion fan will continue to run until the grill has cooled to 110°F.



## COLD WEATHER COOKING

Just because the bright coloured leaves are gone and the golf clubs put away for another season doesn't mean you have to stop barbecuing. The clean crisp fresh air and the heavenly aroma of flavoured wood pellets and food cooking may be just what the doctor ordered to cure those winter blahs. Holiday grilling also frees up your oven space for other important menu items. Following are a few suggestions on how to enjoy your grill throughout those cooler months.

- ORGANIZE. – Get everything you require ready in the kitchen before you head out to the great outdoors. Put what you need on a tray, bundle up tight, and go for it!
- During the winter move your grill to an area that is out of the wind and cold. Check local bylaws regarding the proximity of your grill in relation to your home and/or other structures.
- **Caution: Never grill in an unventilated area!**
- To help you keep track of the outside temperature, you should place an outdoor thermometer close to your cooking area. This will help in determine how long it will take to cook your food.
- You may want to keep a log or little written history on what you cooked, the temperature outside, and the results. This will help latter down the road to help you determine what to cook and how long it will take.
- When cooking in cold weather, it is better to increase your pre-heating time by at least 20 minutes.
- Avoid lifting the grill lid any more than necessary. Cold gusts of wind can completely cool your grill temperature. Be flexible with your serving time; add about 10 – 15 minutes extra cooking time each time you open the lid.
- As always, use a meat thermometer to determine the internal temperature of your foods.
- Because the nights come sooner in the colder months, it is a good ideal to work in a lighted area or to have a light or flashlight close by.
- Have a heated platter and maybe a cover ready to help keep your food warm while making the trip back inside.
- Some of your better foods for winter cooking are those that require little attention, like roasts, whole chicken, ribs, and turkey. Make you meal preparation even easier by adding vegetables and potatoes.

## HOT WEATHER COOKING

Following are a few tips on hot weather cooking. As it gets hotter outside, not only will the cooking times of your food decrease but the cooking time on you decrease. Proper dress is a must. Shorts, T-shirt, sandals, hat, apron and a generous slab of suntan lotion go without say. Don't forget the big tall cool drink; we don't want the chef to become dehydrated.

- ORGANIZE – You don't have to serve a huge seven-course meal. You don't want to be cleaning your entire kitchen after every meal. Timing is everything to cooking outside and remember practise does make perfect. So practise lots!!!
- Adjust your cooking temperatures downward. This helps to avoid those unwanted flare-ups.
- As always, use a meat thermometer to determine the internal temperature of your foods. This helps in preventing your meat from over cooking and drying out.
- Even in hot weather, it is still better to cook with the lid of your grill down.
- You can keep foods hot by wrapping them in foil and placing them in an insulated cooler. Stuff crumpled up newspaper around the foil and this will keep food hot for a good 3 to 4 hours.
- Try to keep your menu on the lighter side. So you can enjoy the warm temperatures and quality family times.



## GRILL MAINTENANCE

There are two extremes when it comes to keeping the grill clean. Those that must spit and shine the entire grill, in and out, after every use, and those whom are convinced that cleaning only takes away from that barbeque flavour. One simple rule; everything in moderation.

### TIP

**Be diligent in you cleaning and maintenance program. Taking care of your grill will add years of life to it and keeps it looking great.**

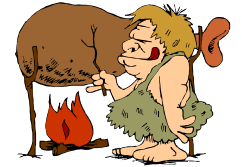

### Starting Out Right

**A little time and effort at the beginning of the season will not only help extend the life of your grill but will also ensure the reliability of it, and make you look like the “King or Queen of the Grill”! Most of the cleaning techniques are above.**

### Stainless Steel Working Surfaces

ALWAYS clean dirt and dust off all stainless steel surfaces before you begin to cook. The dirt can cook into the metal and discolour it. These can be easily cleaned with hot soapy water and a soft cloth. A quick swipe of WD40 and a soft rag will also work, but you must be careful not to apply it to the painted surfaces or interior parts. With the popularity of stainless steel appliances increasing, there are now many commercial products made to clean and protect stainless steel surfaces.

### Paint Grade Surfaces

Be sure to preheat the unit for a least 15-20 before using for the first time. This allows the paint to cure and allows the new paint smoke and smell to burn off. Once cured it can be washed with hot soapy water. Some barbeque faithful will then apply a light coat of vegetable oil to highlight the finish. Using flat black stove paint can always touch up the paint. We use “Stove Bright” brand. Stove Bright also makes many more colors in high-heat stove paint, if you ever wanted to change the look. It is sold at most pellet stove retail outlets.

### Cast Iron Grills

When new, wash thoroughly with warm soapy water, and then “Season” the grills. For more detailed information see the section specifically on Cast Iron Grills near the beginning of this manual.

### “Grill Mate” Cooking Grate

After the completion of grilling, turn the grill to high until only an occasional wisp of smoke is seen (about 5 minutes). This will remove most of the material that builds up on the “Grillmate”. The next time you grill allow the grill to preheat on high for 5 – 10 minutes to complete the cleaning cycle. See the section relating to the “Grill Mate” for full cleaning instructions.

### “Flavor Guard” Cooking Grate

This requires very little work, because of its construction and the type of material used. From time to time you may need to brush off any burnt leftover. The best time to clean is when you through the initial set-up procedures after every 5 to10 uses.



## The Firebox

Because the firebox is used to channel the fan forced air into the burn grate, there is very little maintenance to be done in this area. Occasionally you may either vacuum or brush out any build-up of ash or burn debris that has fallen below the burn grate. You will also want to visually check the air holes in the igniter tube. Clean any debris or blockage out of both areas to ensure a perfect start.

## Stainless Steel Burn Grate

Periodically check the air holes found in the sides of the burn grate for any blockages or build-ups. Using a wire brush or flat-head screwdriver, scrape off any build up or blockage. When reinstalling the grate also confirm the proper positioning in the burn pot. The grate should be level from side to side and from front to back as well as should have a snug but not tight fit. You may have to adjust the tab, found under the front lip, using a pair of pliers to move the tab inward or outward.

- A. Burn Box  
Combustion air brought into the Backside and through the burn Grate bottom, back, and front
- B. "SUPER" Grate  
Stainless steel construction, Solid bottom notched for igniter And air holes on front and back
- C. Adjustable Tab  
Used to fine tune and Level grate

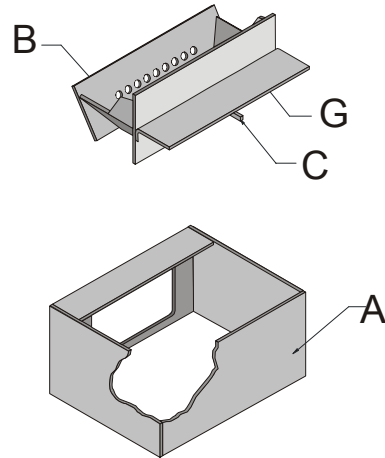

## Ash/Grease Tray

Always be sure the ash/grease pull out pan is clean and free of debris. To make cleaning a breeze you can line the ash catcher with foil wrap. During the warmer months empty any grease build-up on a more frequent basis to avoid it from going rancid and to avoid having any extra creatures enjoying your grill.

## Slowing Down . . . Not Putting Away for the Season

We recommend that at least once a month, while your grill is cold, that you should perform not only the above maintenance procedures, but also include the following:

Using a stiff vegetable brush knock-off any built-up scale on the inside walls of your grill. Check the inside of the lid, the smoke deflector, and the inside walls of the cooking area.

Using an old paintbrush, brush off any ash build-up found inside the firebox, grate, and flame deflector areas.

Finally give your entire grill a good cleaning with a shop vac.



## LIMITED WARRANTY

The "Louisiana Grill" wood pellet barbecue line, manufactured by Canadian Comfort Industries (CCI), carries a five (5) year limited warranty for from the date of sale to the original owner only, against defects and workmanship on all steel parts, (excluding the burn grate), and two (2) years on electrical components. There is no specific warranty on the paint, burn grate, grill cover and all gaskets or against damage caused from corrosion.

## Conditions of Limited Warranty

1. During the term of the limited warranty, CCI's obligation shall be limited to furnishing a replacement for covered, failed components, F.O.B. point of shipment. As long as it is within the warranty period, CCI will not charge for repair or replacement for parts returned, freight prepaid, if the part(s) are found by CCI to be defective upon examination. CCI shall not be liable for transportation charges, labor costs, or export duties. Except as provided in this CONDITIONS OF WARRANTY paragraph, repair or replacement of parts in the manner and for the period of time stipulated hereunder shall constitute the fulfillment of all direct and derivate liabilities and obligations from CCI to you.
2. The warranty coverage begins on the original date of purchase and proof of date of purchase is required to validate the warranty.
3. Repair or replacement of the "Louisiana Grill" part does not extend the limited warranty beyond the five (5) years or two (2) years from date of purchase.
4. The pouring of liquids on your grill flame will void this warranty.
5. CCI takes every precaution to utilize materials that retard rust by using high-temperature paint where advisable. Even with these safeguards, the protective coatings can be compromised by various substances and conditions beyond CCI's control. High temperatures, excessive humidity, chlorine, industrial fumes, fertilizers, lawn pesticides and salt are some of the substances that can affect paint and metal coatings. For these reasons, the limited warranties DO NOT COVER RUST OR ALUMINUM OXIDATION, unless there is loss of structural integrity on the grill component. Should any of the above occur, kindly refer to you Instruction Manual's maintenance section for paint finish protection. CCI recommends that you purchase a CCI full-length protective cover, and cover your grill when not in use.
6. The warranties are based on normal domestic use and service of the grill and neither limited warranty coverage apply for a grill, which is used in commercial applications.



## LIMITED WARRANTY

### Exceptions to the Limited Warranty

There is no written or implied performance warranty on “Louisiana Grills” appliances, as the manufacturer has no control over the installation, operations, cleaning, maintenance or the type of fuel burned.

This limited warranty will not apply nor will CCI assume responsibility if your appliance has not been installed, operated, cleaned and maintained in strict accordance with the manufacturer’s instructions. Burning other than quality wood pellets may void the warranty. The warranty does not cover damage or breakage due to misuse, improper handling or modifications.

**NEITHER THE MANUFACTURER, NOR THE SUPPLIERS TO THE PURCHASER, ACCEPTS RESPONSIBILITY, LEGAL OR OTHERWISE, FOR THE INCIDENTAL OR CONSEQUENTIAL DAMAGE TO THE PROPERTY OR PERSONS RESULTING FROM THE USE OF THIS PRODUCT. ANY WARRANTY IMPLIED BY LAW, INCLUDING BUT NOT LIMITED TO IMPLIED WARRANTIES OF MERCHANTABILITY OR FITNESS, SHALL BE LIMITED TO ONE (1) YEAR FROM THE DATE OF ORIGINAL PURCHASE. WHETHER A CLAIM IS MADE AGAINST THE MANUFACTURER BASED ON THE BREACH OF THIS WARRANTY OR ANY OTHER TYPE OF WARRANTY EXPRESSED OR IMPLIED BY LAW, MANUFACTURER SHALL IN NO EVENT BE LIABLE FOR ANY SPECIAL, INDIRECT, CONSEQUENTIAL OR OTHER DAMAGES OF ANY NATURE WHATSOEVER IN EXCESS OF THE ORIGINAL PURCHASE PRICE OF THIS PRODUCT. ALL WARRANTIES BY MANUFACTURER ARE SET FORTH HEREIN AND NO CLAIM SHALL BE MADE AGAINST MANUFACTURER ON ANY ORAL WARRANTY OR REPRESENTATION.**

Some states do not allow the exclusion or limitation of incidental or consequential damages, or limitations of implied warranties, so the limitations or exclusions set forth in this limited warranty may not apply to you. This limited warranty gives you specific legal rights and you may have other rights, which vary from state to state

The limited warranties for 5 (five) years or 2 (two) years are in lieu of all other warranties expressed or implied, at law or otherwise, and CCI does not authorize any person or representative to assume for CCI any obligation or liability in connection with the sale of the wood pellet grill. This means that no warranties, either expressed or implied, are extended to persons who purchase the product from any one other than CCI or an authorized CCI Distributor.

### Procedures for Warranty Service

Call your nearest “Louisiana Grills” dealer for repair or replacement of your “in-warranty” parts.

Be prepared to furnish the following information:

1. Purchaser’s name, model and serial number of grill and date of purchase.
2. An accurate description of the problem.

**THIS LIMITED WARRANTY GIVES YOU SPECIFIC LEGAL RIGHTS AND YOU MAY HAVE OTHER RIGHTS, WHICH VARY FROM STATE TO STATE**



## NOTES



## GRILLING GEAR

### DRESS TO PROTECT

#### Oven Mitts

This has to be one of the most overlooked accessories. Look for ones that are flameproof, and are longer in the sleeve, about 16" in length, this helps protect your arm particularly when basting large cuts of meat, or anytime you open up the cooking hood. They will also protect your bare arms from hot food splatter or grease. Also look for ones that are soil and water repellent, to protect the mitt's appearance against spills and stains.

#### Apron

The equivalent to the handyman's tool belt. Most good aprons will have an adjustable neck strap for that perfect fit, and lots of pockets for bottles, a towel or two and tools. Should be machine washable.

#### Shoes

Always wear closed shoes, not steel toed unless your cooking skills need refinement, to protect your feet from dripping grease or falling utensils.

### THE RIGHT TOOLS FOR THE JOB

#### Meat Thermometer (A Must)

The outside temperature, wind conditions, pellet fuel variety and the altitude at which you live affect grill temperatures. The hood thermometer is only an approximate temperature and should be used as a guide only. The best way to ensure your meat has come up to the proper temperature and is ready to eat is to use a meat thermometer. Purchase a good quality **instant read meat thermometer**, remembering that these are to be left in the meat for one minute, not the entire cooking time. To use, plunge the thermometer into the thickest part of the meat, making sure the tip is not touching a bone. A long-handled, long-needled thermometer is useful for large cuts of meat and poultry. Instant-read thermometers also are available in digital models, some even with a wireless, remote readout.

#### Tongs

Use tongs rather than a fork for turning and handling meats to avoid losing the natural juices. Extra large ones allow you to grip a variety of delicate foods and extra long handles

#### Basting Brush

You may need a selection of these, because you should not use the same brush in two different marinades. Used to apply your favourite sauces and marinades to foods on the grill. Again look for one with a long handle, to keep your hands away from the heat. Natural bristles that are cut at a 45° angle make it easier to baste large cuts of meat.

#### Spatulas / Turner

A must for turning those delicious burgers and fish filets. Again as with any grilling tools look for a long, sturdy handle and the widest blade possible. The holes in the blade prevent the build-up of steam, which could make your food soggy.

#### Timer

Using a timer will help to alert you when "well-done" is about to become "over-done".

#### Aluminium Foil

Extra-strength foil is always useful for grilling. Used to make foil packages, wrap smores, or to fold up into a flat dish to act as a drip pan to catch those flavourful juices that drip from the meat. Also used to speed up cooking, protect bones from burning, and to keep foods warm. Can also be used to wrap a large piece of cardboard to become a whole fish flipper.

#### Drip / Roast Pans

Used to prevent flare-ups, keeps food from drying out, eliminates basting, and catch those flavourful juices that drip from the meat and used to make the most delicious gravy ever. Various juices can also be added to the pan to impart a desired flavour, such as apple, lemon, cranberry, pineapple, any cola, etc.

#### Grill Baskets

Perfect for cooking food that are difficult to handle on the grill, such as vegetables, seafood, fish and certain cuts of meats. Usually made out of nickel-plated steel these baskets are made of two identical halves being held together with hinges. Not only do they protect food, and make handling easier, but also allows for different food to be combined and grilled together without piercing the food.

#### Griddle

One of the most used accessories for those grill enthusiasts that enjoy cooking any foods outdoor. Use to griddle complete breakfasts, grill sandwiches, and toast fajitas. Cook all your bacon and sausages outdoors, and they're great for grilling vegetables, stir-frying, and searing.

#### Cooking Racks

Nickel-plated roast racks and rib racks are a great way to increase your cooking pleasure. Roast racks can be used to enhance the convective cooking capabilities of your grill, by allowing the smoke flavoured air to move around the entire roast evenly. Rib racks are a great way to increase your capacity of your grill for those large gatherings. Can also be used for chops and chicken pieces.

#### Skewers (wood or metal)

Wood skewers adhere better to meat than do the metal ones. When using the wood skewers remember to soak them in water for at least 30 minutes beforehand to prevent them from burning in the heat of the grill. Another way to protect them would be to wrap the exposed ends with aluminium foil. Metal skewers should be those with flat blades or dual prong. The flat skewer is designed to prevent the food from rotating when you turn the skewer. The dual prong skewers hold all foods more securely and are ideal way to hold delicate meats and vegetables.

#### Metal Brush

It is important to clean your grill thoroughly before each use. A long handled brush with metal bristles is the best tool for the job.

#### Skillets and Woks

**These baskets of course allow you to stir-grill vegetables, seafood, and other small pieces of food the same way you would if you were indoors. The holes allow the smoke and flavors to reach the food.**



## GRILLING TIPS AND TECHNIQUES

### HELPFUL HINTS

Before preheating the grill, make sure it is safe, clean and hygienic.

Wipe off all stainless steel surfaces before preheating. Dirt and food stains will cook into the surface.

Ensure the ash/drip pan is clean and free from any debris and fat build-up.

Always check your pellet fuel hopper for debris and to ensure that you do not run out of pellets before finishing.

Always preheat your grill before cooking. After ignition has taken place turn your control knob to the PREHEAT setting, be sure the lid is closed and allow the grill to heat for at least 10 – 15 minutes or until the thermometer registers over 500° F.

To prevent foods from sticking, you can brush or rub cooking oil on the cast iron grills. If using a vegetable spray use it only before lighting the burn pot. Never spray the grill while there is fire in the burn pot.

Sear meats and cook with the lid down for perfectly grill food every time.

All Louisiana Grills are designed to allow even fan forced heat circulation, so foods cook evenly on all sides. Leave at least 1" of clearance between the food and the hood for proper heat flow.

Grilling times in recipes are based on 70°F (20°C) weather and little to no wind. Allow more time on cold, windy days, or even for higher altitudes. Allow less time for warmer weather.

Grilling times in charts and recipes are approximate.

Large or thicker pieces of meat will require more cooking time per pound than smaller or thinner pieces.

Foods on a crowded cooking grate will require more cooking time than just a few foods.

Foods grilled in containers, such as baked beans, will require more time if grilled in a deep casserole rather than a shallow baking pan.

Use long-handled tongs for turning all meats and spatulas for turning burgers and fish. Do not use a fork for turning, as it will pierce the meat allowing the flavourful juices to escape.

Determine the doneness of meats by making a small slit near the bone and checking the colour. For boneless cuts, make a slit near the centre. For thicker cuts or larger pieces of meat and poultry insert an instant-read thermometer into the centre of the largest muscle of meat or in the inner thigh or breast of poultry. Charring meat, poultry or fish is not recommended.

When grilling any meats, poultry or any food remember moisture retention is a must: sear the outside first to lock in juices; add salt, if needed, after cooking; flip cuts of meat when bubbles start to appear so the moisture goes back into the meat; sauces are best applied near the end of cooking to prevent burning; and always use tongs, not a fork.

## FOOD SAFETY TIPS AND TECHNIQUES

We want you to enjoy healthy and safe grill cooking, so following are some hints for basic barbecue hygiene:

### Food Handling

Wash hands thoroughly with hot, soapy water before starting any meal preparation and after handling fresh meat, fish and poultry.

Use a different platter and utensils for the cooked meat than the ones you used to prepare or bring the raw meat out to the grill. This will prevent cross contamination of bacteria.

Use a different utensil for each marinade or basting sauce to prevent cross contamination.

Keep hot foods hot (above 140°F) and cold foods cold (below 37°F)

Do not leave hot foods out of refrigeration for more than two hours.

Cooked foods and salads should not be left out in the heat for more than an hour. Fill a deep tray or casserole dish with ice to keep salads cool and safe.

Do not defrost meat at room temperature or on a counter top.

Marinate meat in the refrigerator. Bacteria are living organisms that grow and multiply rapidly in warm, moist foods.

A marinade should never be saved to use on a later day. If you are going to use it to serve with your meat, be sure to bring it to a boil before serving.

Always use a meat thermometer to determine the internal temperature of the foods you are cooking.

It's a good idea to put grilled food onto a heated platter, to help keep the food warm. Steaks benefit from resting for several minutes before serving. It allows those delicious juices that were driven to the surface by heat to ease back to the center.



## COOKING FOR A CROWD

### TIP

*The number one rule for cooking for a crowd is PLANNING! The second would be to use only tried and proven recipes. Grilling should be fun and stress free leave new recipes for your everyday cooking.*

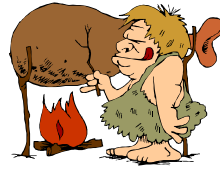

Planning includes not only a menu, but also the complete party. Chairs, tables, dishes, utensils, entertainment, and planned or unplanned weather conditions. Rented beverage coolers, extra table and chairs, or maybe even a tent may be added conveniences to consider.

Select menu items that can be completely or partially prepared in advance – salads, condiments, casseroles, breads, baked goods, and smoked meats. Try smoking a turkey the day before for big event. A turkey will pick up more of the smoke flavour after setting in the refrigerator over night and because of the convection cooking of your grill the meat will be just as juicy as if done straight of the grill.

Grill “time proven” classics such as burgers, chicken pieces, hot dogs or sausages – all great tasting and easy to grill.

Make a list of every food item you will be serving so that nothing will be forgotten in the rush.

Working backward from a planned serving time, decide when to start cooking each food so that everything is ready at the right time. Make a schedule for cooking foods on the grill, plus any indoor cooking.

Plan a serving dish and utensil for each food and have those items. Heavy-duty paper plates come in many attractive colors and patterns and will save dishwashing later. Paper or plastic beverage cups are a must if having any little ones, or young at heart, around.

### TIP

*To cut down on dishwashing and using every cup in your cupboard, purchase plastic or styro-foam cups. Have your quests create their own personalized decorated cup using markers, crayons and a little creativity.*

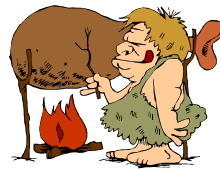

Grill the meat or entrée at the specific recipe temperature, making adjustments with vegetables, side dishes and breads if necessary.

Better yet, let everyone lend a hand, bring a favorite side dish, serve buffet, and have a great time at your own party!