

This Owner's Manual is provided and hosted by [Appliance Factory Parts](http://www.appliancefactoryparts.com).

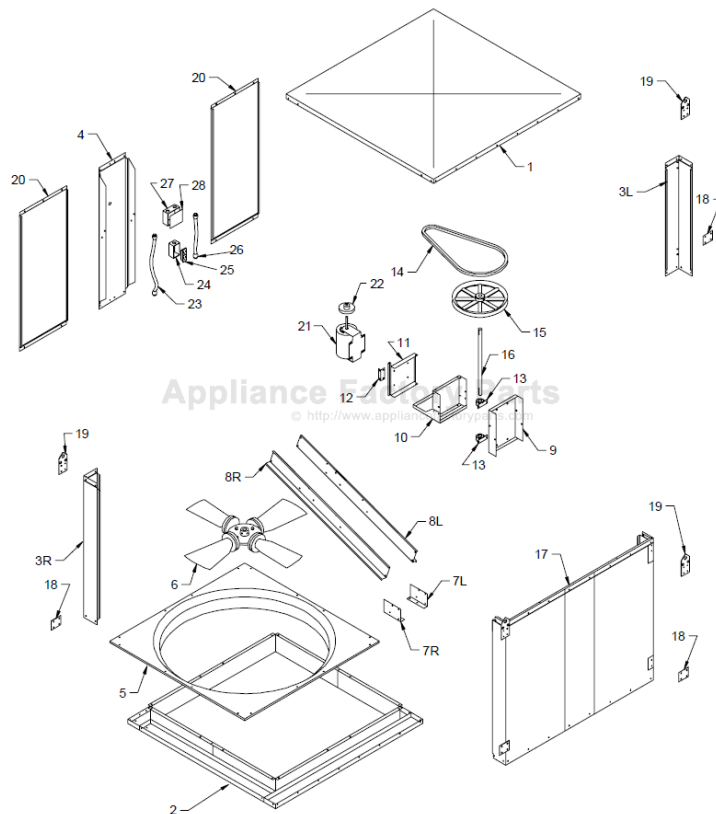

MASTERCool FAD242B Owner's Manual

[Shop genuine replacement parts for MASTERCool FAD242B](#)



[Find Your MASTERCool Evaporative Cooler Parts - Select From 136 Models](#)

----- Manual continues below part list -----

Available Replacement Parts for MASTERCOOL FAD242B

214120-001	CONNECT BRACKET FOR: ALL COMMERCIAL MAST
110355	BEARING - 1" BALL - FOR: AD/AS/SAD/SAS10
110156	SHAFT W/KEYWAY (SOLID) FOR: FAD242/248B

High Capacity Axial Fan Evaporative Cooler

Model Series

FAD242

FAD248



Circle the model of your cooler and record the serial number below.

Encierre con un circulo el modelo de su enfriador y escribe el número de serie abajo.

Serial #
Número de Serie _____

Read Carefully All Of This Manual Before Installing The Unit

Lea Con Cuidado Todo Este Manual Antes De Instalar La Unidad

Table Of Contents

Safety Instructions	1	Warranty	4
Operation	1	General Specifications (<i>Especificaciones Generales</i>)	5
Installation Instructions	2	Motor Specifications (<i>Especificaciones Del Motor</i>)	5
Maintenance Section	2-3	Parts List - Blower Section (<i>Lista De Piezas</i>)	6-7
Electrical Wiring Diagrams	3	Parts List - Wet Section (<i>Lista De Piezas</i>)	8-9
Troubleshooting	4	Spanish (<i>Instrucciones en Español</i>)	9-12

Read And Save These Instructions

Safety Rules

1. Read instructions carefully.
2. Disconnect all electrical service that will be used for the unit before you begin the installation.
3. Electrical hook up should be done by a qualified electrician, so that all electrical wiring will conform to your local standards.
4. For a maximum safety precaution, make sure cooler cabinet is properly grounded to a suitable ground connection.
5. Cooler must be connected to proper line current, voltage and cycle, as stamped on cooler motor and pump motor specification plate.

6. This unit must be installed at a height of 10 feet or greater from the floor.
7. Always **Disconnect Power** before performing any maintenance.

Operation

To eliminate delivery of hot air when starting cooler, Start the pump without the blower for the first few minutes, then turn on the blower motor.

These coolers may be used without water for ventilation purposes. When outside air is cool (for example, at night) or when humidity is high the water pump can be turned off.

Installation

⚠CAUTION: Make sure that the mounting surface is strong enough to support the operating weight of the cooler when in use. (For operating weight, see Specification Table.)

⚠CAUTION: Never start cooler until installation is complete and unit has been tested for rigidity.

⚠CAUTION: This unit must be installed at a height of 10 feet or greater from the floor.

Electrical Installation

NOTE: Local building code regulations must be observed.

⚠WARNING: Disconnect all electrical service that will be used for this unit before you begin the installation.

- **Connect electrical.** Cooler must be connected to the proper line current, voltage and cycle, as indicated on the decal located at the electrical service entrance. Connecting improper voltage to motor will void motor warranty. See the wiring diagrams (figures 8 & 9) on page 3 for wiring electrical connections.

NOTE: A separate 120 Volt, 60 Hz, 1 phase pump electrical circuit is required to maintain the integrity of the GFCI pump protection and to maintain the U.L. Listing of the evaporative cooler.

- **Wire gage.** The horse power, voltage, cycle, phase, current, and length of wire required from switch to motor will determine the gage of wire to be used.

- **Switches.** Larger horsepower and three phase applications require switches (not supplied) of proper current capacity and should be installed by a competent electrician.

- **Power Supply box.** The power supply box is located in the upper inside of the divider channel. Remove the cover to access wiring. (Fig. 1). Connect wiring in box to power supply wiring as per wiring diagrams.

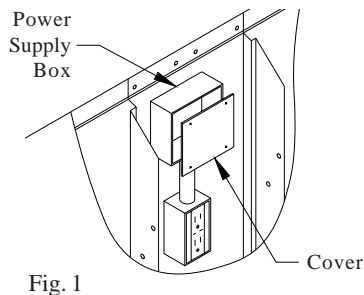

Fig. 1

⚠WARNING: Make sure that cooler cabinet is properly grounded to a suitable ground connection for maximum safety.

Water Connection

- **Pumps.** Plug the pumps into the pump receptacles. There are metal cord retaining clips on the corner post and motor cross braces for retaining the pump cords.

⚠CAUTION: The pump cord must be secured to prevent it from dropping into water reservoirs or contacting moving components.

- **Install overflow assembly.** Remove nut and place nipple through the hole in the pan, with the rubber washer between the pan and the head of the drain nipple (Fig. 2). Screw on nut and draw up tight against bottom of pan. Insert overflow pipe in nipple to retain water. Overflow pipe may be removed to drain pan when necessary. A garden hose may be screwed on the drain nipple to drain water away from your unit.

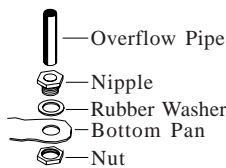

Fig. 2

- **Connect water supply line.** A water supply line should be run to the cooler to supply an adequate amount of cold water to the unit. The amount of water each cooler uses will depend on the weather conditions in your area and the size of your unit. The hotter and dryer your climate and the higher the capacity of your unit, the more water will evaporate. For example: An FAD248 unit with a 2 hp motor will use approximately 85 gallons per hour in a hot and dry climate like Las Vegas on a 105°F day with 10% humidity. The same unit in a cooler climate with 95°F and 20% humidity would use approximately 63 gph.

NOTE: Do not connect the water supply line to any soft water applications.

- **Install float valve and fill pan.** Refer to Fig. 3. Remove items 1, 2, 3, and 4. Insert float body (5) through hole in back post panel as shown. Install washer (1) and nut (2). Tighten to keep float from turning. Place nut (4) and ferrule (3) on water supply line. Connect to float fitting and tighten until water tight. Loosen screw (6) and adjust rod (7) until water level is within 1" of top of reservoir. Tighten screw (6). Slide float shield (8) up over float body (5) until it snaps into place.

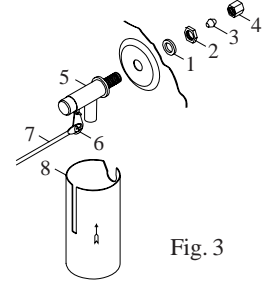

Fig. 3

- **Bleed-Off.** Use of the bleed-off kit is recommended to prevent scale build up by bleeding off small amounts of circulating water during operation. Do not add any type of water treatment chemicals to the water.

Maintenance

⚠WARNING: Before doing any maintenance be sure to disconnect from power source. This is for your safety.

Spring Start-Up

- **Check belt tension.** A 3 lb. force should deflect the belt 3/4 inches (see Fig. 4). Readjust belt if needed.

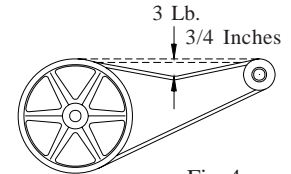

Fig. 4

To adjust belt, loosen the two hinge nuts and the locking nut on the adjusting bolt as shown in figure 5. Loosen or tighten the adjustment nut until the belt is at the right tension. Lock the motor plate in place by tightening the locking nut and then tighten the 2 hinge nuts.

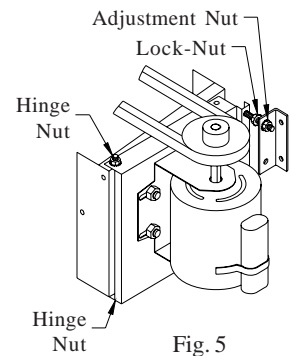

Fig. 5

- **Grease bearings.** The shaft bearings in this unit should be greased once a year with a good grade of ball bearing grease.

- **Clean pads.** A clean pad is more absorbent, efficient and will give more cool air. Annually, or when required, using a garden hose with nozzle, back wash to clean out the openings, then clean off the inlet face any scale or other obstruction to the passages. Slight scraping may be required to remove hardened scale.

- **Pad replacement.** The pads should be replaced after 5 years or before if necessary. To change pads, remove top access panel, remove grill, and disconnect water delivery tube. Remove water distributor holder and lift out media sections. Replace with the same type media. You can purchase them from your dealer.

IMPORTANT: In order to get the best performance from your cooling pads, they must be installed properly. If you have purchased a pad with two equal angles, the following instructions can be disregarded. Pads must always be installed with the steeper flute angle sloping down towards the air entering side (Fig. 6). The reason is simple. The steeper angle puts more water on the hot, dry, dirty side of the pad where it is needed most. It also counteracts the tendency of the air to push the water toward the back of the pad.

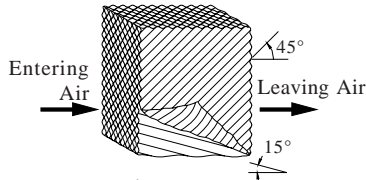

Fig. 6

- **Cleaning pumps.** Cleaning the pumps is necessary once a year at start-up. For your safety, disconnect from power source and unplug pump. Remove the pump from the mount bracket. Remove the base of the pump (Fig. 7). Clean the pump and turn the impeller to ensure free operation. Remove the

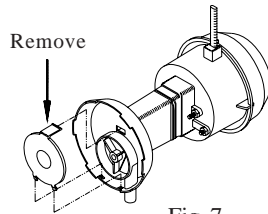

Fig. 7

pump spout and check for any blockage. After cleaning, reinstall the base onto the pump. Reattach the pump to the mount in the cooler to ensure that the pump will not overturn. Do not forget to replace the spout and water delivery tube onto the pump outlet.

NOTE: The pump has automatic reset thermal protection. The pump motor will stop if it overheats. The pump will operate normal again after obstruction is cleared.

- **Check bleed-off valve to be sure it is not clogged.**

Winter Shut Down

- **Drain water.** Always drain all of the water out of the cooler and water supply line when not in use for prolonged periods, and particularly at the end of the season. Keep the water line disconnected from both the unit and water supply so that water will not seep into the line and freeze.

- **Disconnect from power supply when not in use for extended periods of time.**

- **Cover unit.** To protect the life of the finish, a cover for the unit is suggested in extended periods of non use.

By following the operating, installation, and maintenance suggestions as outlined, you can get many years of efficient and satisfactory service from your cooler. In the event additional information is desired, your dealer will be more than glad to assist you in every possible way.

Wiring Diagrams

For 1 or 2 HP, 1 Phase Motor

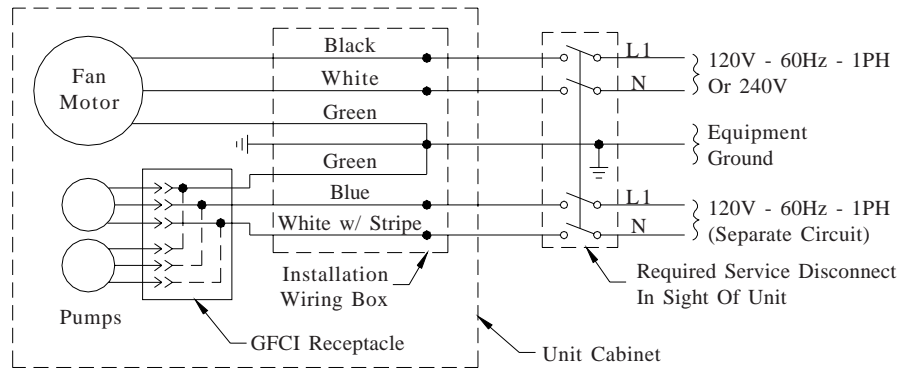

Fig. 8

For 1 or 2 HP, 3 Phase Motor

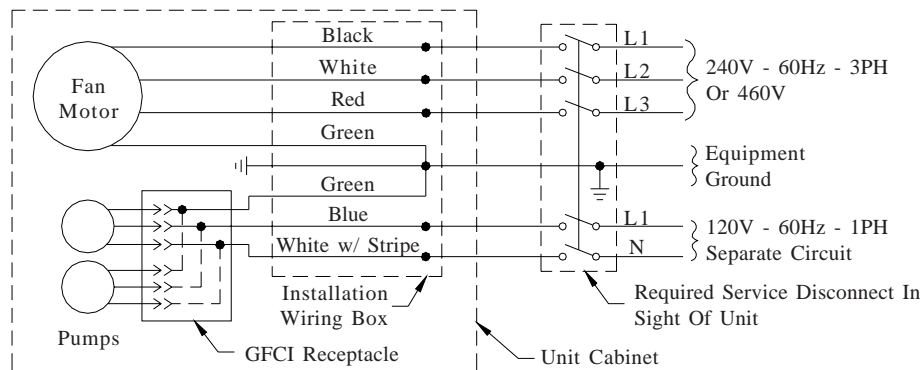

Fig. 9

Troubleshooting Guide

<u>Problem</u>	<u>Possible Cause</u>	<u>Remedy</u>
Failure to start or no air delivery	1. No electrical power to unit <ul style="list-style-type: none"> • Fuse blown • Circuit breaker tripped 	1. Check power <ul style="list-style-type: none"> • Replace fuse • Reset breaker
	2. Belt too loose or tight	2. Adjust belt tension
	3. Motor overheated <ul style="list-style-type: none"> • Belt too tight • Blower bearings dry 	3. Determine cause of overheating <ul style="list-style-type: none"> • Adjust belt tension • Grease blower bearings
	4. Motor locked	4. Replace motor
Inadequate air delivery with cooler running	1. Insufficient air exhaust	1. Open windows or doors to increase air flow
	2. Belt too loose	2. Adjust belt tension or replace if needed
	3. Pads plugged	3. Clean pads
	4. Insufficient water flow over pads	4. Clean distribution system
Motor cycles on and off	1. Low voltage	1. Check voltage
	2. Excessive belt tension	2. Adjust belt tension
	3. Fan shaft tight or locked	3. Grease or replace bearings (Disconnect unit)
	4. Bearings dry	4. Grease bearings
	5. Faulty motor	5. Replace motor

<u>Problem</u>	<u>Possible Cause</u>	<u>Remedy</u>
Musty or unpleasant odor	1. Stale or stagnate water in cooler	1. Drain pan and clean pads
	2. Pads not wetting properly <ul style="list-style-type: none"> • Dist. tube holes clogged • Pump not working properly • Insufficient water flow over pads 	2. Check water distribution system <ul style="list-style-type: none"> • Clean • Replace or clean pump (Unplug) • Clean water distribution system
	1. Bearings dry	1. Grease bearings
	2. Loose parts	2. Tighten loose parts
Inadequate cooling	1. Inadequate exhaust in building	1. Open windows or doors to increase air flow
	2. Pads not wet <ul style="list-style-type: none"> • Pads plugged • Dist. tube holes clogged • Pump not working properly 	2. Check water distribution system <ul style="list-style-type: none"> • Clean pads • Clean • Replace or clean pump (Unplug)
	1. Inadequate exhaust	1. Open doors or windows

Limited Warranty

This warranty is extended to the original purchaser of an evaporative cooler installed and used under normal conditions. It does not cover damages incurred through accident, neglect, or abuse by the owner. We do not authorize any person or representative to assume for us any other or different liability in connection with this product.

Terms And Conditions Of Warranty

Lifetime Limited Coverage on water reservoir against any leakage due to defects in material. From date of purchase, if any original component part fails due to defect in material or factory workmanship only, we will provide the replacement part as follows:

- One year on the cabinet components.
- Two years on the evaporative media.

Exclusions From The Warranty

We are not responsible for any incidental or consequential damage resulting from any malfunction.

We are not responsible for any damage received from the use of water softeners, chemicals, descale material, plastic wrap, or if a motor of a higher horsepower than what is shown on the serial plate is used in the unit.

We are not responsible for the cost of service calls to diagnose cause of trouble, or labor charge to repair and/or replace parts.

How To Obtain Service Under This Warranty

Contact the Dealer where you purchased the evaporative cooler. If for any reason you are not satisfied with the response from the dealer, contact the Customer Service Department: 5800 Murray Street, Little Rock, Arkansas 72209. 1-800-643-8341. E-mail: info@championcooler.com, Web: www.championcooler.com.

This limited warranty applies to original purchaser only

General Specifications / Especificaciones Generales

Model Series <i>Serie de Modelo</i>	*Weight (lbs.) <i>Peso (libras)</i>		Cabinet Dimensions (in.) <i>Dimensiones De La Caja (pulgadas)</i>			Duct Opening (in.) <i>Abertura De Ducto (pulgadas)</i>	
	Dry <i>Seco</i>	Operating <i>Lleno</i>	Height <i>Altura</i>	Width <i>Anchura</i>	Depth <i>Profundidad</i>	Width <i>Anchura</i>	Height <i>Altura</i>
FAD242	761	1041	42 ¹ / ₈	97 ¹ / ₄	60 ¹ / ₄	46	46
FAD248	789	1069	52 ¹ / ₈	97 ¹ / ₄	60 ¹ / ₄	52	52

*The weight includes a 2 HP motor. / *El peso total incluye el peso de un motor de 2 C.V.*

Motor Specifications / Especificaciones Del Motor

Model <i>Modelo</i>	Motor <i>Motor</i>	HP <i>C.V.</i>	Phase <i>Fase</i>	Volts <i>Voltios</i>	Shaft (in.) <i>Eje (pulgadas)</i>	Motor Pulley <i>Polea De Motor</i>	Drive Belt <i>Correa</i>
FAD242B111	110457	1	1	115	5/8	110316	110212 (4L570)
FAD242B112	110457	1	1	208-230	5/8	110316	110212 (4L570)
FAD242B132	110462-1	1	3	208-230	5/8	110316	110212 (4L570)
FAD242B134	110462-1	1	3	460	5/8	110316	110212 (4L570)
FAD242B211	110483	2	1	115	5/8	110317	110227 (4L580)
FAD242B212	110483	2	1	208-230	5/8	110317	110227 (4L580)
FAD242B232	110464-1	2	3	208-230	5/8	110317	110227 (4L580)
FAD242B234	110464-1	2	3	460	5/8	110317	110227 (4L580)
FAD248B211	110483	2	1	115	5/8	110317	110227 (4L580)
FAD248B212	110483	2	1	208-230	5/8	110317	110227 (4L580)
FAD248B232	110464-1	2	3	208-230	5/8	110317	110227 (4L580)
FAD248B234	110464-1	2	3	460	5/8	110317	110227 (4L580)

NOTE: All motors are single speed. For more information on motors contact your dealer. /

NOTA: Todos los motores son de una velocidad. Si desea más información establece contacto con su comerciante.

Replacement Parts Drawing / Dibujo De Piezas De Repuesto

FAD242B, FAD248B

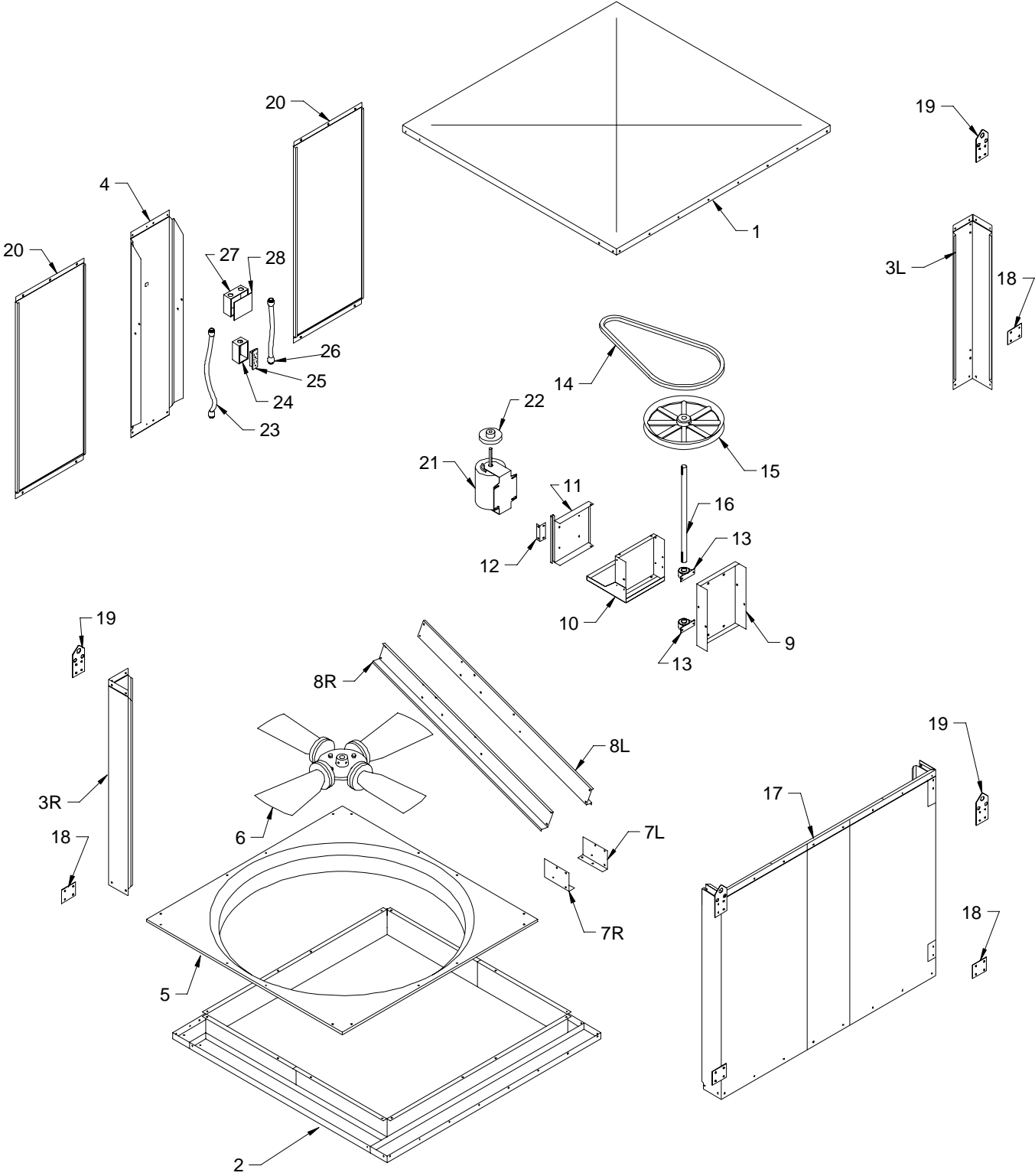

Replacement Parts List / *Lista De Piezas De Repuesto*

All parts may be ordered from your dealer, but not directly from the factory. Be sure that you furnish the following information on all orders. / *Todas las partes pueden ser pedidas con su concesionario, pero no directamente a la fábrica. Incluya toda la información siguiente con su pedido:*

1. Cooler serial number / *Número de serie de la unidad*
2. Description and part number / *Descripción y número de parte*
3. Cooler size / *Tamaño de la unidad*
4. Date of purchase / *Fecha de compra*

Failure to supply all of this information will delay your order. / *El no proporcionar toda esta información resultará en una demora.*

No.	<u>N°</u> Description / <u>Descripción</u>	<u>FAD242B</u>	<u>FAD248B</u>
1.	Top, Cabinet / <i>Tapa De La Caja</i> -----	216117-003	216117-003
2.	Bottom, Cabinet / <i>Base De La Caja</i> -----	316117-008	316117-012
3R.	Corner Post, Right / <i>Poste De Esquina, Derecha</i> -----	318117-026	318117-033
3L.	Corner Post, Left / <i>Poste De Esquina, Izquierda</i> -----	318117-027	318117-032
4.	Divider Channel / <i>Panel Divisora</i> -----	218117-028	218117-034
5.	Venturi Plate / <i>Venturi</i> -----	216117-011	216117-015
6.	Fan Blade / <i>Palas del Ventilador</i> -----	110841	110842
7R.	Bottom Connect Bracket, Right / <i>Abrazadera Del Conectar De Abajo, Derecha</i> -----	214109-004	214109-008
7L.	Bottom Connect Bracket, Left / <i>Abrazadera Del Conectar De Abajo, Izquierda</i> -----	214109-011	214109-010
8R.	Drive Channel, Right / <i>Soporte Para El Sistema De Transmisión, Derecha</i> -----	214109-005	214109-005
8L.	Drive Channel, Left / <i>Soporte Para El Sistema De Transmisión, Izquierda</i> -----	214109-003	214109-003
9.	Bearing Mount / <i>Soporte Para Los Cojinetes</i> -----	214109-009	214109-009
10.	Motor Mount / <i>Montura Del Motor</i> -----	314109-006	314109-006
11.	Motor Mount Adjustment Plate / <i>Placa Ajustable Del Montura Del Motor</i> -----	214109-007	214109-007
12.	Belt Adjustment Support Angle / <i>Ángulo De Soporte Para Ajustar El Correa</i> -----	211101-001	211101-001
13.	Bearings, Fan Blade / <i>Cojinetes Del Eje Del Ventilador</i> -----	110355	110355
14.	Drive Belt / <i>Correa</i> -----	*	*
15.	Pulley, Fan / <i>Polea Del Ventilador</i> -----	110282	110282
16.	Shaft, Fan / <i>Eje Del Ventilador</i> -----	110156	110156
17.	Front Panel / <i>Panel Del Frente</i> -----	318117-024	318117-030
18.	Connect Bracket / <i>Abrazadera Del Conectar</i> -----	214120-001	214120-001
19.	Lift Bracket / <i>Soporte De Levantamiento</i> -----	212101-001	212101-001
20.	Inspection Panel / <i>Panel De Inspección</i> -----	220116-008	220116-009
21.	Motor / <i>Motor</i> -----	*	*
22.	Pulley, Motor / <i>Polea Del Motor</i> -----	*	*
23.	Electrical Conduit / <i>Conducto Eléctrico</i> -----	110816	110816
24.	Pump Receptacle Box And Cover / <i>Caja De Empalme Y Cubierta Para Las Bombas</i> -----	110821	110821
25.	GFCI Receptacle / <i>Receptáculo GFCI</i> -----	110818	110818
26.	Liquid Tight Non-Metalic connector / <i>Conector Estanco De No Metálico</i> -----	110817	110817
27.	Power Supply Box / <i>Caja De Empalme Principal</i> -----	110815	110815
28.	Cover, Power Supply Box / <i>Cubierta De La Caja De Empalme</i> -----	110815-1	110815-1

* See motor specification table. / *Vea la tabla de especificaciones del motor.*

NOTE: Standard hardware items may be purchased from your local hardware store.

NOTA: *Artículos de uso corriente pueden comprarse en la ferretería de su localidad.*

Replacement Parts Drawing / Dibujo De Piezas De Repuesto

FAD242W8, FAD248W8

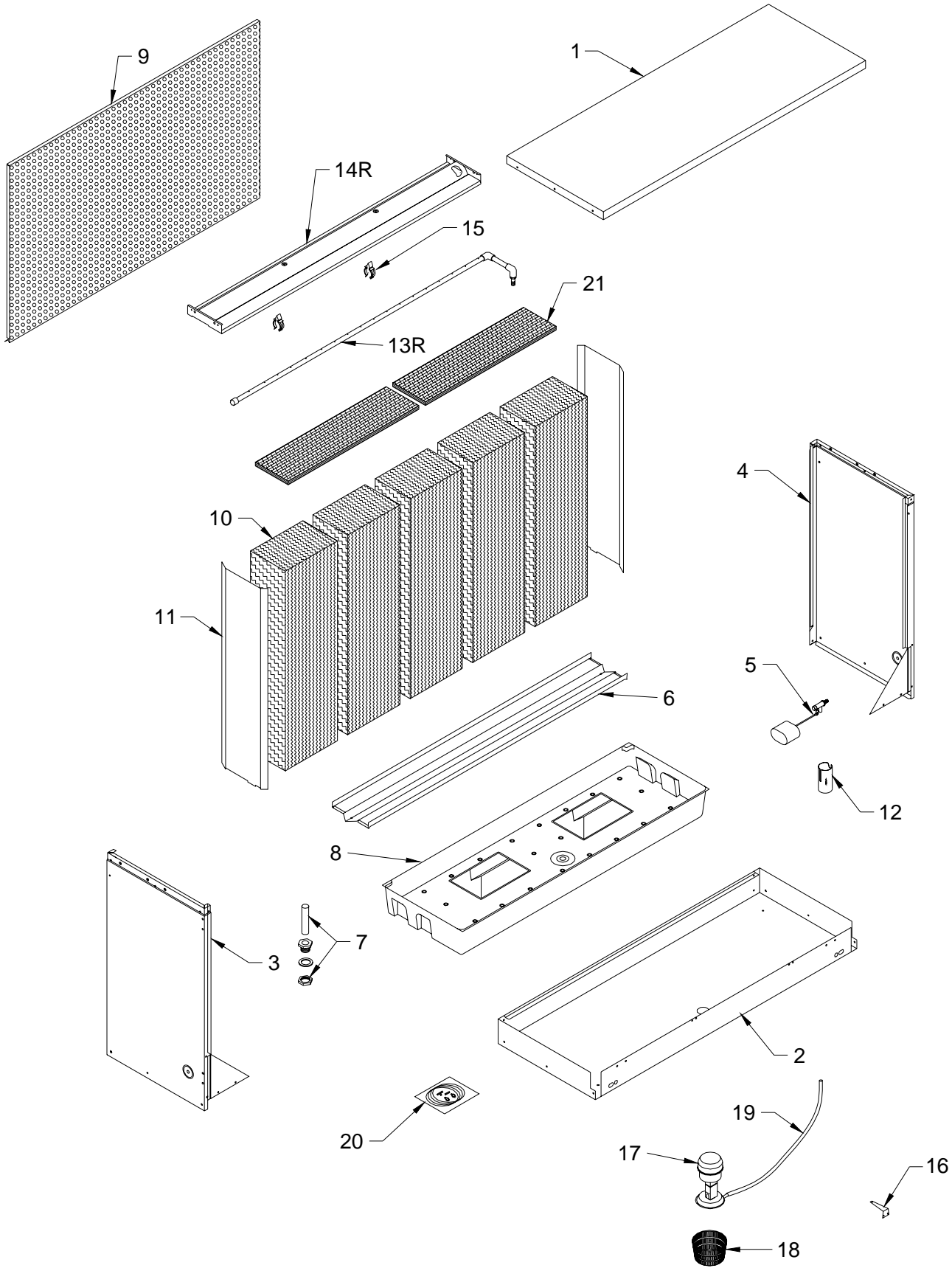

Replacement Parts List / Lista De Piezas De Repuesto

All parts may be ordered from your dealer, but not directly from the factory. Be sure that you furnish the following information on all orders. / Todas las partes pueden ser pedidas con su concesionario, pero no directamente a la fábrica. Incluya toda la información siguiente con su pedido:

1. Cooler serial number / Número de serie de la unidad
2. Description and part number / Descripción y número de parte
3. Cooler size / Tamaño de la unidad
4. Date of purchase / Fecha de compra

Failure to supply all of this information will delay your order. / El no proporcionar toda esta información resultará en una demora.

No. N°	<u>Description / Descripción</u>	<u>FAD242W8</u>	<u>FAD248W8</u>
1.	Top Access Panel / Panel Superior De Acceso -----	218116-030	218116-030
2.	Bottom, Cabinet / Base De La Caja -----	218116-031	218116-031
3.	Side Panel, Right / Panel Del Lado, Derecha -----	318116-028	318116-047
4.	Side Panel, Left / Panel Del Lado, Izquierda -----	318116-027	318116-046
5.	Float Valve / Flotador -----	FL 3/8	FL 3/8
6.	Support, Media / Soporte Para El Medio Evaporativo -----	218116-029	218116-029
7.	Over Flow Assembly / Montaje De Desagüe -----	3OA-2	3OA-2
8.	Water Reservoir / Bandeja Acumuladora De Agua -----	281036	281036
9.	Perforated Panel / Parrilla Perforada -----	218126-005	218126-006
10.	Evaporative Media / Medio Evaporativo -----	110115	110116
11.	Media Shield / Pantalla Protectora Para El Medio Evaporativo -----	281026-011	281026-012
12.	Float Shield / Pantalla Protectora Del Flotador -----	281005-001	281005-001
13R.	Water Distributor Assembly, Right (Shown) / Sistema Del Distribuidor De Agua, Derecho (Mostrado) -----	3D-28R	3D-28R
13L.	Water Distributor Assembly, Left / Sistema Del Distribuidor De Agua, Izquierdo -----	3D-28L	3D-28L
14R.	Water Distributor Housing, Right (Shown) / Caja Del Distribuidor De Agua, Derecho (Mostrado) -----	322140-043	322140-043
14L.	Water Distributor Housing, Left / Caja Del Distribuidor De Agua, Izquierdo -----	322140-039	322140-039
15.	Water Distributor Tube Clamp / Abrazadera De Tubo Del Distribuidor De Agua -----	110591	110591
16.	Pump Mount / Montura De La Bomba -----	218122-004	218122-004
17.	Pump Assembly / Bomba -----	110467	110467
18.	Pump Screen / Malla Para La Bomba -----	281001-001	281001-001
19.	Tube, Water Delivery / Tubo De Agua -----	110717	110717
20.	Bleed-Off Kit / Equipo De La Válvula De Desahogo -----	310587	310587
21.	Polyester Pad / Filtro De Poliester -----	110119-4	110119-4

Lea y Conserve Estas instrucciones

Reglas De Seguridad

1. Lea las instrucciones con cuidado.
2. Desconecte todos los servicios eléctricos que serán usados en esta unidad antes de instalar el enfriador.
3. Las conexiones eléctricas deben ser hechas por un electricista competente, para que todo el cableado eléctrico cumpla con los requisitos establecidos en su localidad.
4. Para una máxima y segura precaución, debe estar muy seguro que la caja del enfriador está conectada con la tierra.
5. El enfriador debe ser conectado con el propio voltaje, corriente alterna y ciclos, lo que se encuentran en la placa de especificaciones de la bomba y del motor.

6. Debe instalar la unidad a lo menos de 10 pies arriba del piso.

7. Siempre **CORTE LA CORRIENTE** antes de realizar cualquier labor de mantenimiento.

Operación

Para que no salga aire caliente al principio, prenda sólo la bomba durante unos cuantos minutos; luego prenda también el motor del ventilador.

Su enfriador puede ser utilizado sin agua para proporcionar ventilación solamente. Cuando esté fresco (por ejemplo, de noche) o cuando la humedad es alta, la bomba de agua puede ser apagada.