

This Owner's Manual is provided and hosted by [Appliance Factory Parts](http://www.appliancefactoryparts.com).

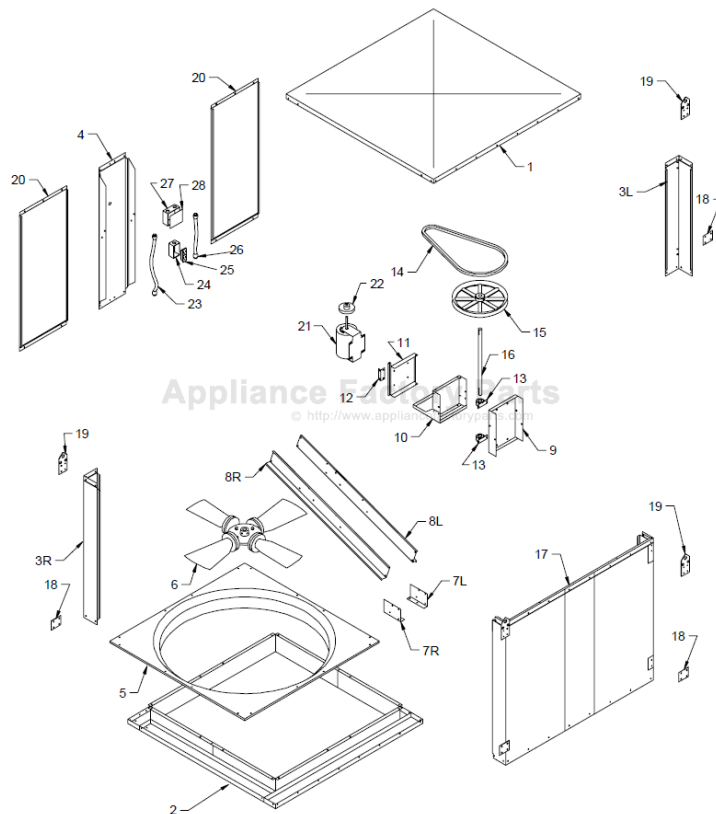

MASTERCool FAD242B Owner's Manual

[Shop genuine replacement parts for MASTERCool FAD242B](#)



[Find Your MASTERCool Evaporative Cooler Parts - Select From 135 Models](#)

----- Manual continues below -----

SPECIFICATIONS & SUBMITTAL DATA

FEATURES:

- Heavy gauge galvanized steel cabinet
- Electrostatically applied Polyester resin powder paint finish
- Thermoplastic water reservoir
- Long life media, efficient and self cleaning
- Greater air flow
- Low maintenance
- Made in the U.S.A.



MODELS

- FAD 242**
- FAD 248**

Project _____

Location _____

Architect _____

Engineer _____

Contractor _____

Submitted By _____ Date _____

Ref. No.	Cooler Model No.	Qty.	CFM	Static Pressure	HP	Volts	Phase
1							
2							
3							
4							
5							
6							
7							
8							
9							

Notes

CHAMPION COOLER
 5800 Murray, Little Rock, AR 72209
 1-800-643-8341
 info@championcooler.com

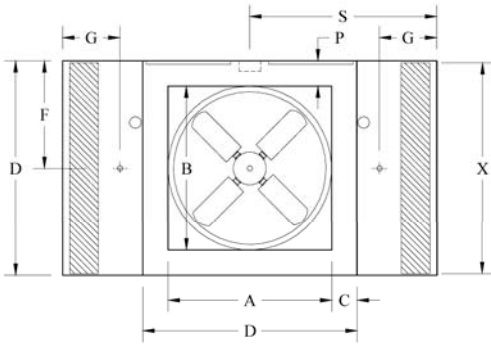

BOTTOM VIEW

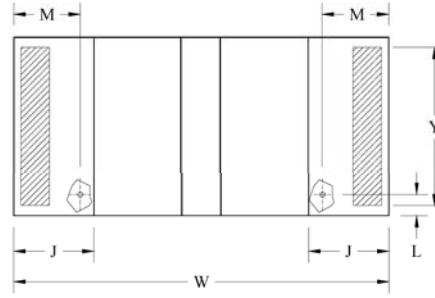

FRONT VIEW

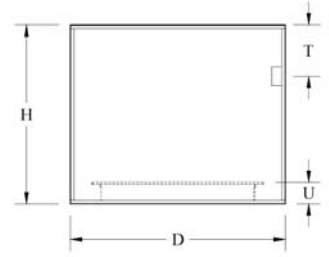

END VIEW

DIMENSIONAL DATA*

BLOWER MODEL NUMBER	CABINET			DUCT OPENING		DUCT LOCATION		DRAIN LOCATION		WET MODULE	BOT. PAN RISER	MEDIA DIMENSION		WATER SERVICE		ELECTRIC SERVICE		APPROX. TOTAL RESERVOIR CAPACITY	APPROXIMATE WEIGHT (LBS)	
	H	W	D	A	B	C	P	F	G	J	U	X	Y	L	M	S	T		DRY	OPER.
FAD 242	40 1/8	97 1/4	60 1/4	46	46	7 1/8	7 1/8	30 1/8	12 1/2	18 1/2	6	60	34 1/2	5 7/8	14 5/8	48 5/8	4 3/4	30 GAL.	706	986
FAD 248	50 1/8	97 1/4	60 1/4	52	52	4 1/8	4 1/8	30 1/8	12 1/2	18 1/2	6	60	44 1/2	5 7/8	14 5/8	48 5/8	14 3/4	30 GAL.	732	1012

* All Measurements in inches.

PERFORMANCE *Certified Air Delivery At .1" Increments Of External Static Pressure (Inches Static Pressure Water Gauge)*

MODEL	BHP	FAN RPM	MOTOR PART NO.	COOLER VOLTAGE	PHASE	FAN MOTOR **AMPS	120V / 60HZ / 1PH TOTAL PUMP *AMPS	0"	0.1"	0.2"
								CFM	CFM	CFM
FAD242B111	1	451	110457	120	1	16	2.4	13906	11869	7714
FAD242B112			110457	208/230	1	8.8/8				
FAD242B132			110462-1	208/230	3	4.6/4.2				
FAD242B134			110462-1	460	3	2.1				
FAD242B211	2	580	110483	120	1	24	2.4	17550	15973	14122
FAD242B212			110483	208/230	1	13.2/12				
FAD242B232			110464-1	208/230	3	7.5/6.8				
FAD242B234			110464-1	460	3	3.4				
FAD248B211	2	608	110483	120	1	24	2.4	21096	19563	18031
FAD248B212			110483	208/230	1	13.2/12				
FAD248B232			110464-1	208/230	3	7.5/6.8				
FAD248B234			110464-1	460	3	3.4				

Performance shown is for installation type A - Free inlet, Free outlet. Performance rating includes the effects of the evaporative media in the air stream. Power rating (BHP) does not include drive losses.

* A separate 120V, 60Hz., 1-Phase pump electric circuit is required to maintain the integrity of the GFCI pump protection and to maintain the U.L. listing of the evaporative cooler. Pump amperage shown is the total of 2 pumps per cooler.

** Amperage shown is from National Electrical code. Use amperage shown on motor nameplate to determine motor protector. All external wiring and components such as disconnects, motor starters, and over-current protection are to be field supplies and are not included as part of the evaporative cooler.

UL Listed. Models FAD242B and FAD248B series coolers are U.L. Listed for non-ducted installations.