

The New Industrial  
**MasterCool**  
 BY CHAMPION COOLER



**Models**

*(Double Inlet)*

**AD100, AS100, AD10012, AS10012**

**AD150, AS150, AD15012, AS15012**

**AD20012, AS20012, AU20012**

*(Single Inlet)*

**SAD100, SAS100, SAD10012, SAS10012**

**SAD150, SAS150, SAD15012, SAS15012**

Circle the model of your cooler and record the serial number below.

*Encierre con un circulo el modelo de su enfriador y escribe el número de serie abajo.*

Serial #  
 Número De Serie \_\_\_\_\_

**Read Carefully All Of This Manual Before Installing The Unit.**

*Lea Con Cuidado Todo Este Manual Antes De Instalar La Unidad.*

**Read And Save These Instructions**

*Vea el Español en el interior.*

**Table Of Contents**

Safety Instructions .....2  
 Operation.....2  
 Installation Instructions.....2-3  
 Maintenance Section.....3  
 Troubleshooting .....4  
 Warranty .....4  
 Electrical Wiring Diagrams.....5  
 General Specifications .....6

Parts List - Wet Section (All models) .....6-7  
 Parts List - Blower Section (AD100B, AD150B, AD200B)..... 8  
 Parts List - Blower Section (AS100B, AS150B, AS200B)..... 9  
 Parts List - Blower Section (AU200B) ..... 10  
 Parts List - Blower Section (Single Inlet Coolers)..... 11  
 Motor Specifications ..... 12  
 Pulley and Belt Kit Specifications ..... 12  
 Spanish (*Instrucciones en Español*).....13-16

## Safety Rules

1. Read instructions carefully.
2. Disconnect all electrical service that will be used for the unit before you begin the installation.
3. Electrical hook up should be done by a qualified electrician, so that all electrical wiring will conform to your local standards.
4. For maximum safety, make sure cooler cabinet is properly grounded to a suitable ground connection.
5. Cooler must be connected to proper line current, voltage and cycle, as stamped on cooler motor and pump motor specification plate.
6. Do not allow pump to tip over and become submerged.
7. Always **TURN OFF POWER** before performing any maintenance.

## Operation

For the best cooling performance, if the pads are dry, pre-wet the pads by running the pump for a few minutes before starting the blower.

These coolers may also be used without water for ventilation purposes. When outside air is cool (for example, at night) or when humidity is high the water pump can be turned off.

**Important:** To cool efficiently, you must exhaust the stale or used air from the building. Open windows or doors or use exhaust fans located away from the cooler and in the direction you wish to cool the air. The air will flow in the direction of the exhaust openings. A common guide for the amount of exhaust opening needed is to have at least 2 square feet of opening per 1000 CFM.

## Installation

**CAUTION:** Make sure that the mounting surface is strong enough to support the operating weight of the cooler when in use. (For operating weight, see the general specification table.)

**CAUTION:** Do not start cooler until installation is complete and unit has been tested for rigidity.

**CAUTION:** Make sure all bolts are securely tightened before starting the cooler.

- **Wet sections.** The wet sections are bolted to the blower section using the connector brackets, lift brackets and bolts provided. Match the colored dots on the wet section to the appropriate dot on the blower section to insure correct installation.
- **Ductwork.** See the General Specification table for dimensions of duct opening. For down discharge units, the duct must go inside the opening. Size these ducts slightly smaller than the duct opening in the cooler. The side and up discharge units have a 1 inch flange. Size these ducts larger than the duct opening to fit over the flange of these units.

**Note:** Curbs are not provided. The installer is responsible for providing curbs or other means to support the cooler.

## Motor Installation

- **Motor mounting.** Slide the heads of the provided carriage bolts into the slots of the adjustable channels. Slide these channels sideways in the slotted holes to align with the holes in the motor base and to align the motor shaft with the blower pulley. Mount the motor to the

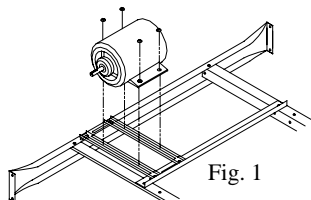

Fig. 1

motor mount using these carriage bolts and the washers and nuts provided (see Fig. 1). Make sure all bolts are securely tightened.

- **Motor pulley.** Install the motor pulley so that it aligns with the blower pulley (see Fig. 2) and tighten set screw. See page 3 for instructions on adjusting pulley.

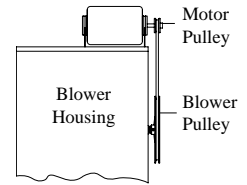

Fig. 2

## Electrical Connection

**NOTE:** Local building code regulations must be observed.

**WARNING:** Disconnect all electrical services that are used for this unit before beginning any service to the cooler.

- **Electrical supply.** Cooler must be supplied with the proper line current, voltage and frequency, as stamped on blower motor and pump motor specification plate. See the wiring diagrams on page 4 for typical electrical connections. **Note: Connecting improper voltage to motor will void motor warranty.**
- **Wire sizing.** The conductor sizes are to be determined by motor loads and length of run per national and local electrical codes.
- **Switches or contactors.** Motors require switches or contactors of proper current capacity and should be sized and installed by a qualified electrician.
- **Wiring.** The electrical junction box is located in the upper inside of the divider channel. Remove the two screws and pull the box out from the channel to access wiring (Fig. 3). Connect the pump supply wiring to the pump receptacles (See the pump wiring diagrams on the next page). Connect the motor supply wiring directly to the blower motor.

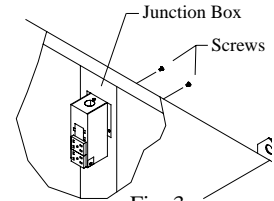

Fig. 3

**WARNING:** Make sure that cooler cabinet is properly grounded to a suitable ground connection for maximum safety.

## Water Connections

- **Overflow assembly.** Remove nut and place nipple through the hole in the pan, with the rubber washer between the pan and the head of the drain nipple (Fig. 4). Screw on nut and draw up tight against bottom of pan. Insert overflow pipe in nipple to retain water. Overflow pipe may be removed to drain pan when necessary. A garden hose may be screwed on the drain nipple to drain water away from your unit.

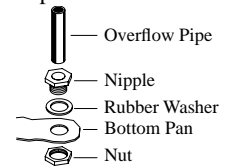

Fig. 4

- **Pump.** The pump must be secured to prevent it from tipping over. Secure the pump to the pump mounting bracket (item 16 in parts drawing). Remove a nut located under the head of the pump, place the pump bolt through the hole in the mounting bracket, and secure with the nut that was previously removed. Plug pump into receptacles. Retain pump cords to internal braces to prevent cords from dropping into water reservoirs or contacting moving components.
- **Supply water.** Run a water supply line to the unit. Each wet section requires a 3/8 inch tube connection to the float valve. The double inlet units will have two float valves, one for each wet section. **Note: Do not use water supplied from a water softener.**
- **Float valve.** Refer to Fig. 5 to install float. Remove items 1, 2, 3, and 4. Insert float body (5) through hole in splash plate (9) and back post panel as shown. Install washer (1) and nut (2). Tighten to

keep float from turning. Place nut (4) and ferrule (3) on water supply line. Connect to float fitting and tighten until water tight. Turn on water supply and check for leaks. Loosen screw (6) and adjust rod (7) until water level is within 1" of top of reservoir. Tighten screw (6). Slide float shield (8) over float body (5) until it snaps into place.

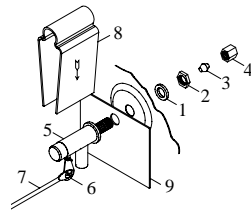

Fig. 5

- **Bleed-Off.** Use of the bleed-off kit is recommended to prevent scale build up by bleeding off small amounts of circulating water during operation. Do not add any type of water treatment chemicals to the water since they may damage the evaporative media.

## Pulley And Belt Adjustments

- **Pulley adjustment.** With an ammeter, check the motor amperage. Adjust the pulley until the amperage draw on the motor is just below that specified on the motor nameplate. To adjust the pulley, loosen the adjustment set screw and rotate the sheave. Tighten the set screw so that it is over a flat area, otherwise thread damage will occur. To increase amperage draw, increase pulley diameter. To decrease amperage draw, decrease pulley diameter (see Fig. 6). Recheck belt alignment.

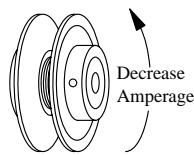

Fig. 6

- **CAUTION:** Always check the amperage of the motor after adjusting pulley to be certain it does not exceed the amperage stamped on the motor specification plate. Improper pulley adjustment will overload and burn out the motor.

- **Belt tension.** Loosen the motor mount bolts and slide the motor back until the belt is properly tensioned. A 3 lb. force should deflect the belt 3/4 inches (see Fig. 7). Retighten motor mount bolts. Do not adjust pulley to tighten belt.

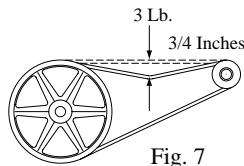

Fig. 7

## Maintenance

- **WARNING:** Before doing any maintenance be sure to disconnect from power source. This is for your safety.

### Spring Start-Up

- **Belt tension.** Check belt tension and readjust if needed.
- **Grease bearings.** The blower bearings in this unit should be greased once a year with a good grade of ball bearing grease.
- **Cleaning pads.** A clean pad is more absorbent, efficient and will give more cool air. Annually, or when required, using a garden hose with nozzle, back wash to clean out the openings, then clean off the inlet face any scale or other obstruction to the passages. Slight scraping may be required to remove hardened scale.

- **Pad replacement.** The pads should be replaced after 5 years or if necessary. To change pads, remove top access panel, remove grill, and disconnect water delivery tube. Remove water distributor holder and lift out media sections. Replace with the same type media. You can purchase them from your dealer.

**IMPORTANT:** In order to get the best performance from your cooling pads, they must be installed properly. If you have purchased a pad with two equal angles, the following instructions can be disregarded. Pads must always be installed with the steeper flute angle sloping down towards the air entering side (Fig. 8). The reason is simple. The steeper angle puts more water on the hot, dry, dirty side of the pad where it is needed most. It also counteracts the tendency of the air to push the water toward the back of the pad.

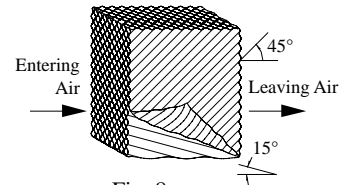

Fig. 8

- **Cleaning pump.** Cleaning the pump is necessary once a year at start-up. For your safety, disconnect from power source and unplug pump. Remove the pump from the mount bracket. Remove the base of the pump (Fig. 9). Clean the pump and turn the impeller to ensure free operation. Remove the pump spout and check for any blockage. After cleaning, reinstall the base onto the pump. Reattach the pump to the mount in the cooler to ensure that the pump will not overturn. Do not forget to replace the spout and water delivery tube onto the pump outlet. The pump has automatic reset thermal protection. Pump will operate normal again after obstruction is cleared.

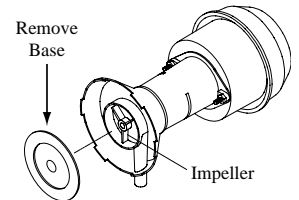

Fig. 9

- **Bleed off.** Check bleed-off valve to be sure it is not clogged.

### Winter Shut Down

- **Drain water.** Always drain all of the water out of the cooler and water supply line when not in use for prolonged periods, and particularly at the end of the season. Keep the water line disconnected from both the unit and water supply so that it does not freeze.
- **Disconnect from power supply when not in use for extended periods of time.**
- **Cover unit.** To protect the life of the finish, a cover for the unit is suggested in extended periods of non use.

By following the operating, installation, and maintenance suggestions as outlined, you can get many years of efficient and satisfactory service from your cooler. In the event additional information is desired, your dealer will be more than glad to assist you in every possible way.

## Pump Wiring Diagrams

### 120 Volts

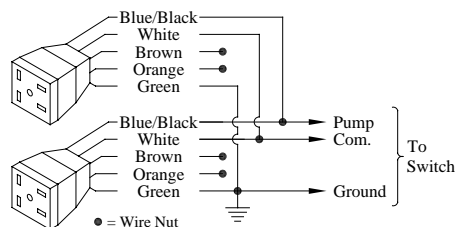

### 240 Volts

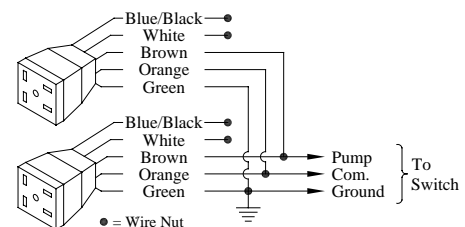

# Troubleshooting Guide

<b>Problem</b>	<b>Possible Cause</b>	<b>Remedy</b>
Failure to start or no air delivery	<ol style="list-style-type: none"> <li>No electrical power to unit                             <ul style="list-style-type: none"> <li>Fuse blown</li> <li>Circuit breaker tripped</li> </ul> </li> <li>Belt too loose or tight</li> <li>Motor overheated                             <ul style="list-style-type: none"> <li>Belt too tight</li> <li>Blower bearings dry</li> <li>Motor bearings dry</li> <li>Motor pulley diameter too large</li> </ul> </li> <li>Motor locked</li> </ol>	<ol style="list-style-type: none"> <li>Check power                             <ul style="list-style-type: none"> <li>Replace fuse</li> <li>Reset breaker</li> </ul> </li> <li>Adjust belt tension</li> <li>Determine cause of overheating                             <ul style="list-style-type: none"> <li>Adjust belt tension</li> <li>Grease blower bearings</li> <li>Oil motor bearings</li> <li>Adjust pulley to correct diameter</li> </ul> </li> <li>Replace motor</li> </ol>
Inadequate air delivery with cooler running	<ol style="list-style-type: none"> <li>Insufficient air exhaust</li> <li>Belt too loose</li> <li>Pads plugged</li> <li>Insufficient water flow over pads</li> </ol>	<ol style="list-style-type: none"> <li>Open windows or doors to increase air flow</li> <li>Adjust belt tension or replace if needed</li> <li>Clean pads</li> <li>Clean distribution system</li> </ol>
Musty or unpleasant odor	<ol style="list-style-type: none"> <li>Stale or stagnate water in cooler</li> <li>Pads not wetting properly                             <ul style="list-style-type: none"> <li>Dist. tube holes clogged</li> <li>Pump not working properly</li> <li>Insufficient water flow over pads</li> </ul> </li> </ol>	<ol style="list-style-type: none"> <li>Drain pan and clean pads</li> <li>Check water distribution system                             <ul style="list-style-type: none"> <li>Clean</li> <li>Replace or clean pump (Unplug)</li> <li>Clean water distribution system</li> </ul> </li> </ol>

<b>Problem</b>	<b>Possible Cause</b>	<b>Remedy</b>
Motor cycles on and off	<ol style="list-style-type: none"> <li>Low voltage</li> <li>Excessive belt tension</li> <li>Blower shaft tight or locked</li> <li>Bearings dry</li> <li>Motor pulley diameter too large causing motor overload</li> <li>Faulty motor</li> </ol>	<ol style="list-style-type: none"> <li>Check voltage</li> <li>Adjust belt tension</li> <li>Grease or replace bearings (Disconnect unit)</li> <li>Grease bearings</li> <li>Adjust pulley so full load ampere rating of motor is not exceeded</li> <li>Replace motor</li> </ol>
Noisy	<ol style="list-style-type: none"> <li>Bearings dry</li> <li>Wheel rubbing blower housing</li> <li>Loose parts</li> </ol>	<ol style="list-style-type: none"> <li>Grease bearings</li> <li>Inspect and realign (Disconnect unit)</li> <li>Tighten loose parts</li> </ol>
Inadequate cooling	<ol style="list-style-type: none"> <li>Inadequate exhaust in house</li> <li>Pads not wet                             <ul style="list-style-type: none"> <li>Pads plugged</li> <li>Dist. tube holes clogged</li> <li>Pump not working properly</li> </ul> </li> </ol>	<ol style="list-style-type: none"> <li>Open windows or doors to increase air flow</li> <li>Check water distribution system                             <ul style="list-style-type: none"> <li>Clean pads</li> <li>Clean</li> <li>Replace or clean pump (Unplug)</li> </ul> </li> </ol>
Excessive humidity in house	<ol style="list-style-type: none"> <li>Inadequate exhaust</li> </ol>	<ol style="list-style-type: none"> <li>Open doors or windows</li> </ol>

Register your product online at [www.championcooler.com/eac/onlineregistration-eac.htm](http://www.championcooler.com/eac/onlineregistration-eac.htm)

## Limited Warranty

This warranty is extended to the original purchaser of an evaporative cooler installed and used under normal conditions. It does not cover damages incurred through accident, neglect, or abuse by the owner. We do not authorize any person or representative to assume for us any other or different liability in connection with this product.

### Terms And Conditions Of The Warranty

Lifetime Limited Coverage on water reservoir against any leakage due to defects in material. From date of purchase, if any original component part fails due to defect in material or factory workmanship only, we will provide the replacement part as follows:

- One year on the cabinet components.
- Two years on the evaporative media.

### Exclusions From The Warranty

We are not responsible for any incidental or consequential damage resulting from any malfunction.

We are not responsible for any damage received from the use of water softeners, chemicals, de-scale material, plastic wrap, or if a motor of a higher horsepower than what is shown on the serial plate is used in the unit.

We are not responsible for the cost of service calls to diagnose cause of trouble, or labor charge to repair and/or replace parts.

### How To Obtain Service Under This Warranty

Contact the Dealer where you purchased the evaporative cooler. If for any reason you are not satisfied with the response from the dealer, contact the Customer Service Department: 5800 Murray Street, Little Rock, Arkansas 72209. 1-800-643-8341. E-mail: [info@championcooler.com](mailto:info@championcooler.com), Web: [www.championcooler.com](http://www.championcooler.com).

**This limited warranty applies to original purchaser only.**

# Typical Electrical Wiring Diagrams

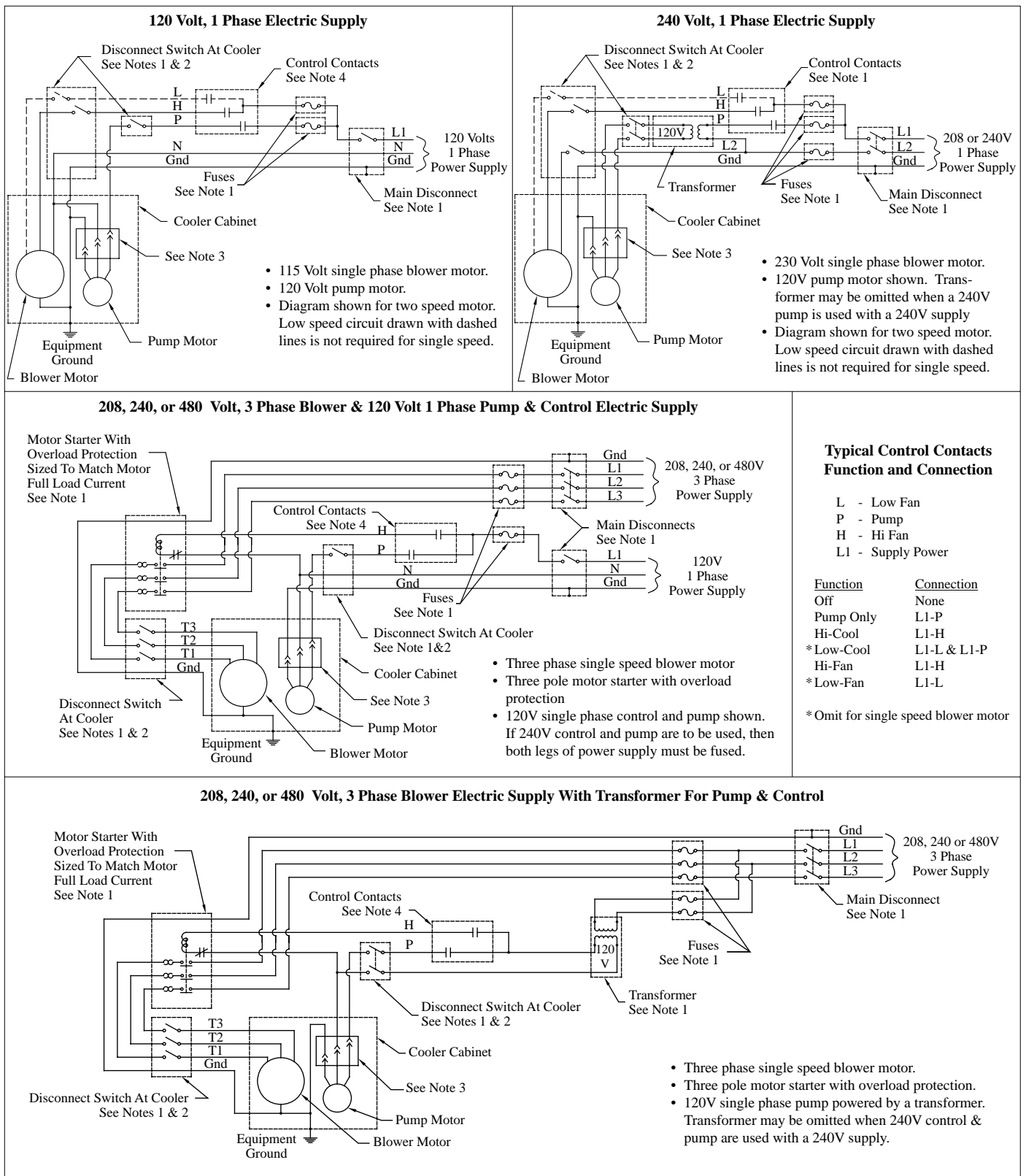

**⚠ WARNING:** Electrical hookup should be performed by a qualified electrician. All electrical wiring must conform to national and local standards.

**NOTE 1.** All switches, motor starters, transformers, fuses, junction boxes, receptacles, receptacle boxes, cover plates, and conductors shall be supplied by the installer.

**NOTE 2.** The national electric code requires a disconnect switch located at equipment if the main disconnect at equipment controller is not visible from the equipment. If more than one disconnect is used they must be mounted adjacent to one another.

**NOTE 3.** A receptacle for a NEMA 5-15P plug is required for 120V recirculating pump and a receptacle for a NEMA 6-15P plug for 230V pump.

**NOTE 4.** The control contacts may be part of a switch, thermostat or other control device.

## General Specifications / Especificaciones Generales

Model No. <i>Modelo</i>	*Weight (lbs.) <i>Peso (libras)</i>		Cabinet Dimensions (in.) <i>Dimensiones De La Caja (pulgadas)</i>			Duct Opening (in.) <i>Abertura De Ducto (pulgadas)</i>	
	*Dry <i>Seco</i>	*Operating <i>Lleno</i>	Height <i>Altura</i>	Width <i>Anchura</i>	Depth <i>Profundidad</i>	Width <i>Anchura</i>	Height <i>Altura</i>
AD100	517	717	44	81 3/4	45	21 3/4	21 3/4
AS100	511	711	44	81 3/4	45	21 3/4	21 3/4
AD10012	571	812	44	89 3/4	45	21 3/4	21 3/4
AS10012	565	806	44	89 3/4	45	21 3/4	21 3/4
AD150	648	863	54	85	48 1/4	26 7/8	26 7/8
AS150	640	856	54	85	48 1/4	26 7/8	26 7/8
AD15012	714	974	54	93	48 1/4	26 7/8	26 7/8
AS15012	706	967	54	93	48 1/4	26 7/8	26 7/8
AD20012	928	1208	59 1/4	105 1/4	60 1/4	31 3/4	31 3/4
AS20012	914	1194	59 1/4	105 1/4	60 1/4	31 3/4	31 3/4
AU20012	914	1194	59 1/4	105 1/4	60 1/4	31 3/4	31 3/4
SAD100	417	517	44	63 3/8	45	21 3/4	21 3/4
SAS100	411	511	44	63 3/8	45	21 3/4	21 3/4
SAD10012	444	565	44	67 3/8	45	21 3/4	21 3/4
SAS10012	438	559	44	67 3/8	45	21 3/4	21 3/4
SAD150	533	641	54	66 5/8	48 1/4	26 7/8	26 7/8
SAS150	525	633	54	66 5/8	48 1/4	26 7/8	26 7/8
SAD15012	566	696	54	70 5/8	48 1/4	26 7/8	26 7/8
SAS15012	558	688	54	70 5/8	48 1/4	26 7/8	26 7/8

\*Does not include motor weight. / No incluye el peso del motor.

## Replacement Parts / Piezas De Repuesto

**SAS/SAD100W, SAS/SAD10012W, SAS/SAD150W, SAS/SAD15012W  
AS/AD100W, AS/AD10012W, AS/AD150W, AS/AD15012W, AS/AD/AU20012W**

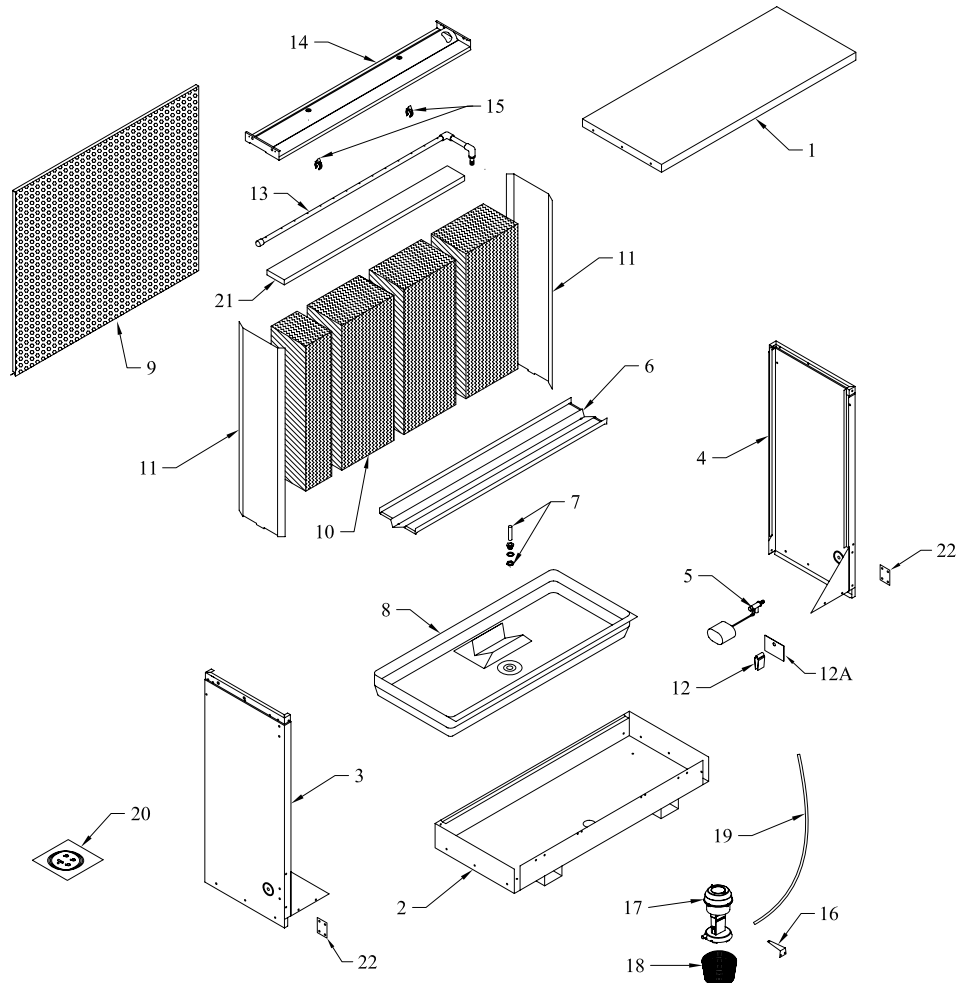

## Replacement Parts / Piezas De Repuesto

When ordering parts, please be sure to furnish the following information on all orders. Failure to do so may delay your order. /  
 Al pedir piezas, incluya toda la información siguiente con su pedido. El no proporcionar toda esta información resultará en una demora.

1. Cooler serial number / Número de serie de la unidad.
2. Description and part number / Descripción y número de pieza.
3. Cooler size / Tamaño de la unidad.
4. Date of purchase / Fecha de compra.

<b>No.</b>	<b><u>N°</u> Description / Descripción</b>	<b><u>100W</u></b>	<b><u>150W</u></b>
1.	Top Access Panel / Panel Superior De Acceso -----	218115-002	218116-007
2.	Bottom, Cabinet / Base De La Caja-----	318115-004	318116-009
3.	Side Panel, Right / Panel Del Lado, Derecho-----	318115-008	318116-013
4.	Side Panel, Left / Panel Del Lado, Izquierdo-----	318115-021	318116-039
5.	Float Valve / Flotador-----	FL-3/8	FL-3/8
6.	Support, Media / Soporte Para El Medio Evaporativo-----	218115-015	218116-020
7.	Over Flow Assembly / Montaje De Desagüe -----	3OA-2	3OA-2
8.	Water Reservoir / Bandeja Acumuladora De Agua -----	281028	281029
9.	Perforated Panel / Parrilla Perforada -----	220126-002	220126-003
10.	Evaporative Media / Medio Evaporativo -----	110107	110106
11.	Media Shield / Pantalla Protectora Para El Medio Evaporativo-----	281026-003	281026-004
12.	Float Shield / Salpicadero Del Flotador-----	281006	281006
12a.	Float Splash Plate / Placa Para Salpicaduras -----	281026-013	281026-013
13.	Water Distributor Assembly / Sistema Del Distribuidor De Agua -----	3D-21R	3D-20R
14.	Water Distributor Housing / Caja Del Distribuidor De Agua -----	322130-059	322140-041
15.	Water Distributor Tube Clamp / Abrazadera De Tubo Del Distribuidor De Agua -----	110591	110591
16.	Pump Mount / Soporte De La Bomba-----	218122-004	218122-004
17.	Pump / Bomba-----	*	*
18.	Pump Screen / Malla Para La Bomba -----	281001-001	281001-001
19.	Tube, Water Delivery / Tubo De Agua -----	110717	110717
20.	Bleed-Off Kit / Equipo De La Válvula De Desahogo -----	310587	310587
21.	Hobbs Polyester Pad / Filtro De Poliester -----	110119-2	110119-3
22.	Connect Bracket / Abrazadera Del Conectar-----	214120-001	214120-001

<b>No.</b>	<b><u>N°</u> Description / Descripción</b>	<b><u>10012W</u></b>	<b><u>15012W</u></b>	<b><u>20012W</u></b>
1.	Top Access Panel / Panel Superior De Acceso -----	218115-016	218116-021	218116-035
2.	Bottom, Cabinet / Base De La Caja-----	318115-017	318116-022	318116-036
3.	Side Panel, Right / Panel Del Lado, Derecho-----	318115-018	318116-023	318116-032
4.	Side Panel, Left / Panel Del Lado, Izquierdo -----	318115-022	318116-040	318116-033
5.	Float Valve / Flotador-----	FL-3/8	FL-3/8	FL-3/8
6.	Support, Media / Soporte Para El Medio Evaporativo-----	218115-019	218116-024	218116-034
7.	Over Flow Assembly / Montaje De Desagüe -----	3OA-2	3OA-2	3OA-2
8.	Water Reservoir / Bandeja Acumuladora De Agua -----	281034	281027	281037
9.	Perforated Panel / Parrilla Perforada -----	220126-002	220126-003	220126-004
10.	Evaporative Media / Medio Evaporativo -----	110111	110110	110112
11.	Media Shield / Pantalla Protectora Para El Medio Evaporativo-----	281026-006	281026-005	281026-008
12.	Float Shield / Salpicadero Del Flotador-----	281006	281006	281006
12a.	Float Splash Plate / Placa Para Salpicaduras -----	281026-013	281026-013	281026-013
13.	Water Distributor Assembly / Sistema Del Distribuidor De Agua -----	3D-25R	3D-24R	3D-28R
14.	Water Distributor Housing / Caja Del Distribuidor De Agua -----	322130-058	322140-042	322140-040
15.	Water Distributor Tube Clamp / Abrazadera De Tubo Del Distribuidor De Agua-----	110591	110591	110591
16.	Pump Mount / Soporte De La Bomba-----	218122-004	218122-004	218122-004
17.	Pump / Bomba-----	*	*	*
18.	Pump Screen / Malla Para La Bomba -----	281001-001	281001-001	281001-001
19.	Tube, Water Delivery / Tubo De Agua -----	110717	110717	110717
20.	Bleed-Off Kit / Equipo De La Válvula De Desahogo -----	310587	310587	310587
21.	Hobbs Polyester Pad / Filtro De Poliester -----	110119-2	110119-3	110119-4
22.	Connect Bracket / Abrazadera Del Conectar-----	214120-001	214120-001	214120-001

\* 115V - 110467  
 230V - 110468

# Replacement Parts / Piezas De Repuesto

## AD100B, AD150B, AD200B

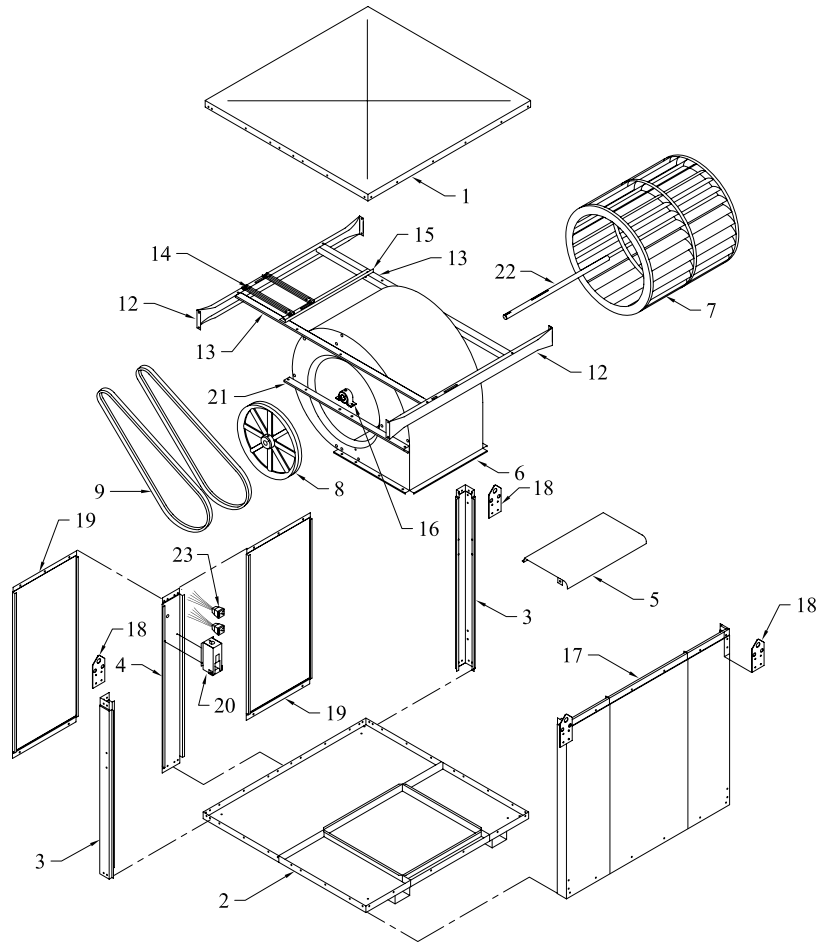

No. N°	Description / Descripción	AD100B	AD150B	AD200B
1.	Top, Cabinet / Tapa De La Caja	218115-003	218116-008	216117-003
2.	Bottom, Cabinet / Base De La Caja	318115-005	318116-010	318117-007
3.	Corner Post / Poste De Esquina	318115-013	318116-018	318117-012
4.	Divider Channel / Canal Divisora	218115-014	218116-019	218117-013
5.	Cut-Off Plate / Placa Limitadora	320102-002	318112-004	318112-003
6.	Blower Housing / Caja De La Rueda	322115-002	320116-001	320117-001
7.	Blower Wheel / Rueda	110749	110750	110751
8.	Pulley, Blower Wheel / Polea De La Rueda	110297	110298	110298
9.	Drive Belt / Correa	†	†	†
10.	Motor / Motor	*	*	*
11.	Pulley, Motor / Polea Del Motor	†	†	†
12.	Channel Retainer / Soporte De Canal	214007-001	214007-006	214109-001
13.	Motor Mount Support / Soporte Para La Montura Del Motor	214118-003	214116-008	206102-001
14.	Motor Mount Adjustable Channel / Montura Ajustable Del Motor	214112-002	214112-004	214112-004
15.	Motor Mount Crossbrace / Travesaño De La Montura Del Motor	214001-005	214001-009	214001-007
16.	Bearings, Blower Wheel Shaft / Cojinetes Del Eje De La Rueda	110355	110356	110356
17.	Front Panel / Panel Del Frente	318115-024	318116-048	318117-011
18.	Lift Bracket / Soporte De Levantamiento	212101-001	212101-001	212101-001
19.	Inspection Panel / Panel De Inspección	220115-003	220116-004	220116-007
20.	Electrical Junction Box / Caja De Empalme	322009-003	322009-003	322009-003
21.	Bearing Mount Support / Soporte Para Los Cojinetes	206100-002	206100-004	206100-005
22.	Shaft, Blower Wheel / Eje De La Rueda	110157	110158	110159
23.	Receptacle, Pump / Toma De Corriente De La Bomba	110361	110361	110361

\* See motor specification table. / Vea la tabla de especificaciones del motor.

† See pulley and belt table. / Vea la tabla de especificaciones del polea y correa.

NOTE: Standard hardware items may be purchased from your local hardware store.

NOTA: Artículos de uso corriente pueden comprarse en la ferretería de su localidad.



# Replacement Parts / Piezas De Repuesto

## AS100B, AS150B, AS200B

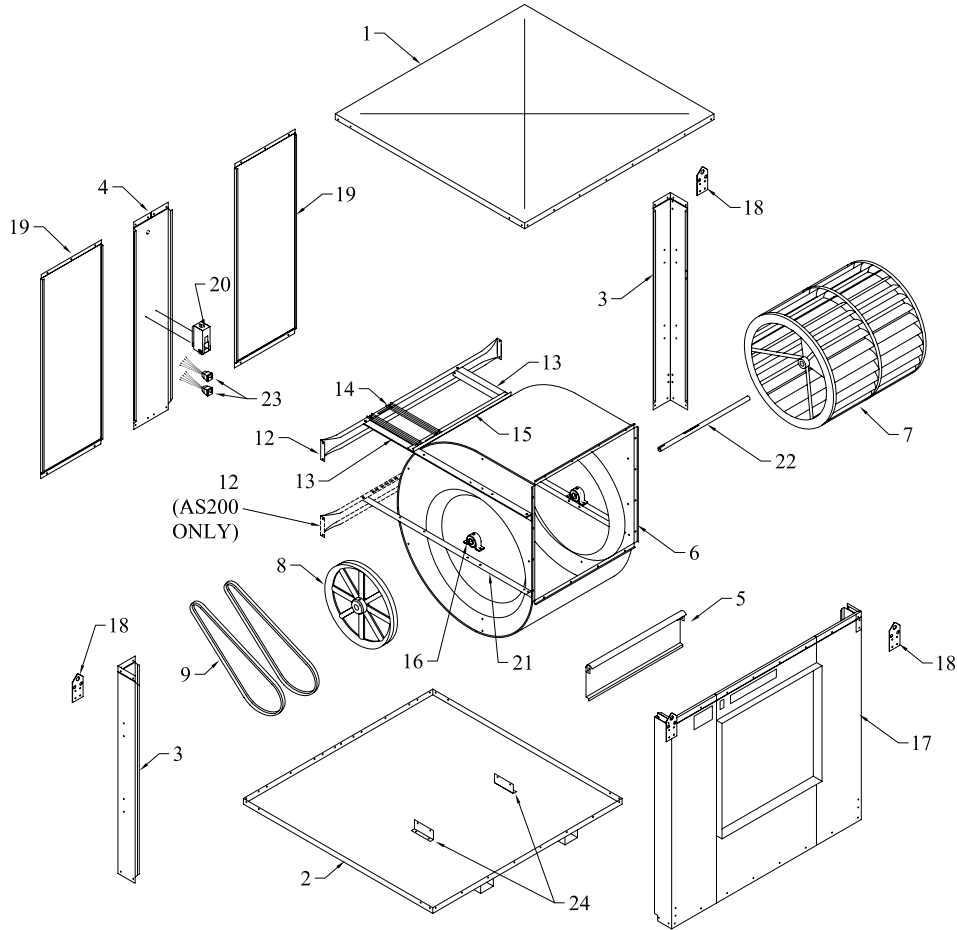

No. N°	Description / Descripción	AS100B	AS150B	AS200B
1.	Top, Cabinet / Tapa De La Caja -----	218115-003	218116-008	216117-003
2.	Bottom, Cabinet / Base De La Caja-----	318115-020	318116-026	316117-004
3.	Corner Post / Poste De Esquina -----	318115-013	318116-018	318117-018
4.	Divider Channel / Canal Divisora-----	218115-014	218116-019	218117-013
5.	Cut-Off Plate / Placa Limitadora-----	320102-002	318112-004	318112-003
6.	Blower Housing / Caja De La Rueda-----	322115-002	320116-001	320117-001
7.	Blower Wheel / Rueda -----	110749	110750	110751
8.	Pulley, Blower Wheel / Polea De La Rueda -----	110297	110298	110298
9.	Drive Belt / Correa-----	†	†	†
10.	Motor / Motor -----	*	*	*
11.	Pulley, Motor / Polea Del Motor -----	†	†	†
12.	Channel Retainer / Soporte De Canal-----	214007-001	214007-006	214109-001
13.	Motor Mount Support / Soporte Para La Montura Del Motor -----	214115-004	214116-009	206102-002
14.	Motor Mount Adjustable Channel / Montura Ajustable Del Motor -----	214112-002	214112-004	214112-004
15.	Motor Mount Crossbrace / Travesaño De La Montura Del Motor -----	214001-005	214001-009	214001-007
16.	Bearings, Blower Wheel Shaft / Cojinetes Del Eje De La Rueda-----	110355	110356	110356
17.	Front Panel / Panel Del Frente-----	318115-009	318116-014	318117-010
18.	Lift Bracket / Soporte De Levantamiento -----	212101-001	212101-001	212101-001
19.	Inspection Panel / Panel De Inspección -----	220115-003	220116-004	220116-007
20.	Electrical Junction Box / Caja De Empalme-----	322009-003	322009-003	322009-003
21.	Bearing Mount Support / Soporte Para Los Cojinetes -----	206100-001	206100-003	206100-006
22.	Shaft, Blower Wheel / Eje De La Rueda -----	110157	110158	110159
23.	Receptacle, Pump / Toma De Corriente De La Bomba-----	110361	110361	110361
24.	Blower Support Bracket / Soporte De La Caja De La Rueda -----	218122-005	218122-005	218122-005

\* See motor specification table. / Vea la tabla de especificaciones del motor.

† See pulley and belt table. / Vea la tabla de especificaciones del polea y correa.

NOTE: Standard hardware items may be purchased from your local hardware store.

NOTA: Artículos de uso corriente pueden comprarse en la ferretería de su localidad.

# Replacement Parts / Piezas De Repuesto

## AU200B

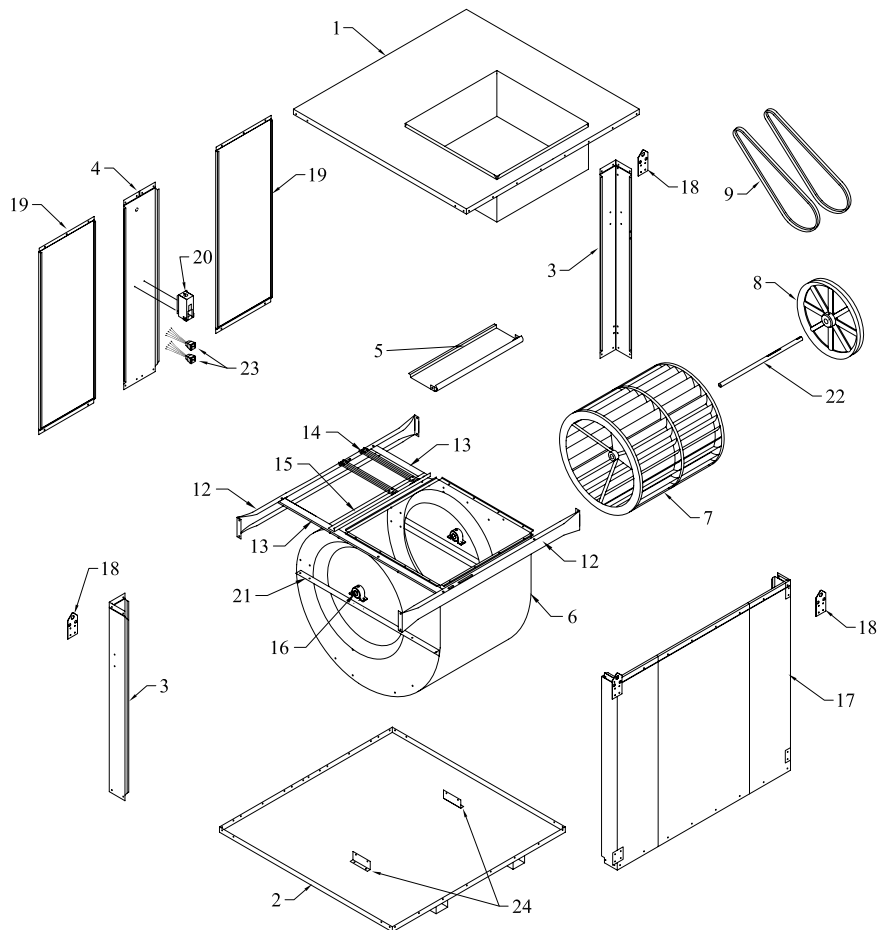

No. <u>N°</u>	<u>Description / Descripción</u>	<u>AU200B</u>
1.	Top, Cabinet / Tapa De La Caja .....	316117-007
2.	Bottom, Cabinet / Base De La Caja.....	316117-004
3.	Corner Post / Poste De Esquina.....	318117-020
4.	Divider Channel / Canal Divisora.....	218117-013
5.	Cut-Off Plate / Placa Limitadora.....	318112-003
6.	Blower Housing / Caja De La Rueda .....	320117-001
7.	Blower Wheel / Rueda .....	110751
8.	Pulley, Blower Wheel / Polea De La Rueda .....	110298
9.	Drive Belt / Correa .....	†
10.	Motor / Motor .....	*
11.	Pulley, Motor / Polea Del Motor .....	†
12.	Channel Retainer / Soporte De Canal.....	214109-002
13.	Motor Mount Support / Soporte Para La Montura Del Motor.....	206102-003
14.	Motor Mount Adjustable Channel / Montura Ajustable Del Motor.....	214112-004
15.	Motor Mount Crossbrace / Travesaño De La Montura Del Motor.....	214001-007
16.	Bearings, Blower Wheel Shaft / Cojinetes Del Eje De La Rueda .....	110356
17.	Front Panel / Panel Del Frente .....	318117-022
18.	Lift Bracket / Soporte De Levantamiento .....	212101-001
19.	Inspection Panel / Panel De Inspección.....	220116-007
20.	Electrical Junction Box / Caja De Empalme .....	322009-003
21.	Bearing Mount Support / Soporte Para Los Cojinetes .....	206100-005
22.	Shaft, Blower Wheel / Eje De La Rueda .....	110159
23.	Receptacle, Pump / Toma De Corriente De La Bomba .....	110361
24.	Blower Support Bracket / Soporte De La Caja De La Rueda .....	218122-005

\* See motor specification table. / *Vea la tabla de especificaciones del motor.*  
 † See pulley and belt table. / *Vea la tabla de especificaciones del polea y correa.*  
 NOTE: Standard hardware items may be purchased from your local hardware store.  
 NOTA: Artículos de uso corriente pueden comprarse en la ferretería de su localidad.

## Replacement Parts / Piezas De Repuesto

### SAD100B, SAD150B

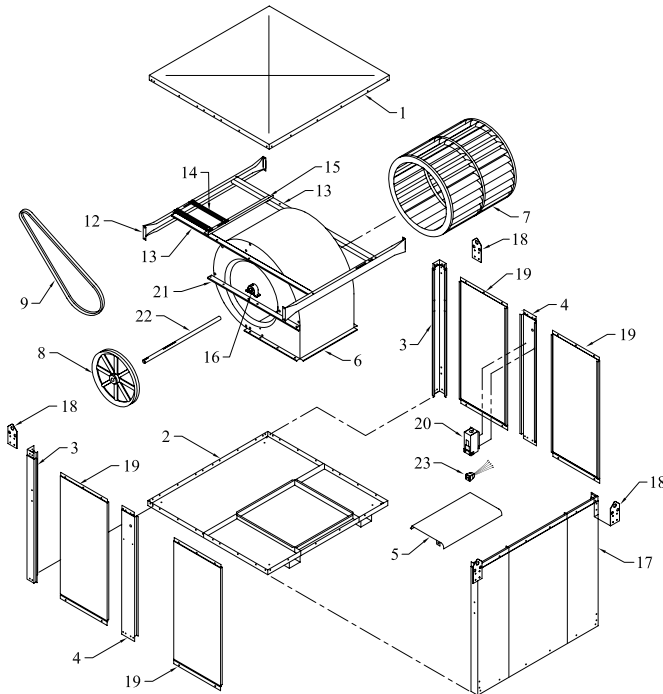

### SAS100B, SAS150B

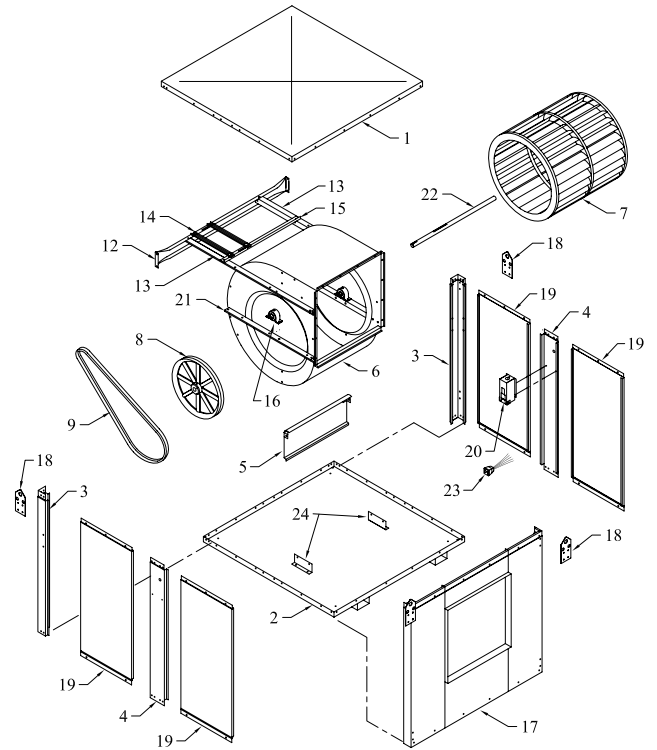

No.

<u>N°</u>	<u>Description / Descripción</u>	<u>SAD100B</u>	<u>SAS100B</u>	<u>SAD150B</u>	<u>SAS150B</u>
1.	Top, Cabinet / Tapa De La Caja .....	218115-003	218115-003	218116-008	218116-008
2.	Bottom, Cabinet / Base De La Caja.....	318115-005	318115-020	318116-010	318116-026
3.	Corner Post / Poste De Esquina.....	318115-013	318115-013	318116-018	318116-018
4.	Divider Channel / Canal Divisora.....	218115-014	218115-014	218116-019	218116-019
5.	Cut-Off Plate / Placa Limitadora.....	320102-002	320102-002	318112-004	318112-004
6.	Blower Housing / Caja De La Rueda .....	322115-002	322115-002	320116-001	320116-001
7.	Blower Wheel / Rueda .....	110749	110749	110750	110750
8.	Pulley, Blower Wheel / Polea De La Rueda.....	110297-1	110297-1	110298-1	110298-1
9.	Drive Belt / Correa .....	†	†	†	†
10.	Motor / Motor .....	*	*	*	*
11.	Pulley, Motor / Polea Del Motor .....	†	†	†	†
12.	Channel Retainer / Soporte De Canal.....	214007-001	214007-001	214007-006	214007-006
13.	Motor Mount Support / Soporte Para La Montura Del Motor.....	214118-003	214115-004	214116-008	214116-009
14.	Motor Mount Adjustable Channel / Montura Ajustable Del Motor.....	214112-002	214112-002	214112-004	214112-004
15.	Motor Mount Crossbrace / Travesaño De La Montura Del Motor.....	214001-005	214001-005	214001-009	214001-006
16.	Bearings, Blower Wheel Shaft / Cojinetes Del Eje De La Rueda .....	110355	110355	110356	110356
17.	Front Panel / Panel Del Frente .....	318115-024	318115-009	318116-048	318116-014
18.	Lift Bracket / Soporte De Levantamiento .....	212101-001	212101-001	212101-001	212101-001
19.	Inspection Panel / Panel De Inspección.....	220115-003	220115-003	220116-004	220116-004
20.	Electrical Junction Box / Caja De Empalme .....	322009-002	322009-002	322009-002	322009-002
21.	Bearing Mount Support / Soporte Para Los Cojinetes .....	206100-002	206100-001	206100-004	206100-003
22.	Shaft, Blower Wheel / Eje De La Rueda .....	110157	110157	110158	110158
23.	Receptacle, Pump / Toma De Corriente De La Bomba .....	110361	110361	110361	110361
24.	Blower Support Bracket / Soporte De La Caja De La Rueda .....	-	218122-005	-	218122-005

\* See motor specification table. / Vea la tabla de especificaciones del motor.

† See pulley and belt table. / Vea la tabla de especificaciones del polea y correa.

NOTE: Standard hardware items may be purchased from your local hardware store.

NOTA: Artículos de uso corriente pueden comprarse en la ferretería de su localidad.

## Motor Specifications / Especificaciones Del Motor

HP C.V.	Motor Part No. Nº Del Motor	Phase Fase	Speed Velocidad	Volts Voltios	Amperage* Amperaje	Weight (lbs.) Peso (libras)	Shaft (in.) Eje (pulgadas)
3/4	110455	1	1	115/208-230	13.8/7.6-6.9	24	5/8
	110461	3	1	208-230/460	3.5-3.2/1.6	20	5/8
1	110457	1	1	115/230	16/8	28	5/8
	110458	1	2	230	8	29	5/8
	+110462-9	3	1	208-230/460	4.6-4.2/2.1	34	7/8
1-1/2	110459-1	1	1	115/208-230	20/11-10	41	5/8
	+110463-9	3	1	208-230/460	6.6-6/3	40	7/8
2	110460-1	1	1	115/208-230	24/13.2-12	50	7/8
	+110464-9	3	1	208-230/460	7.5-6.8/3.4	44	7/8
3	+110465-9	3	1	230/460	9.6/4.8	83	1-1/8
5	+110466-9	3	1	230/460	15.2/7.6	87	1-1/8
7-1/2	+110470-9	3	1	230/460	22/11	121	1-3/8
10	+110482-9	3	1	230/460	28/14	138	1-3/8

+ EPACT Motors / Motores de buen rendimiento.

\* Amperage shown is from National Electrical Code. Use amperage shown on motor nameplate to determine motor protector.

El amperaje listado es del código eléctrico nacional. Utilice el amperaje indicado en la placa del motor para determinar el tamaño del protector del motor.

## Pulley And Belt Specifications / Especificaciones Del Polea y Correa

Model Modelo	HP C.V.	Pulley-Belt Kit Equipo Del Polea y Correa	Motor Pulley Polea De Motor	Drive Belt Correa
SAD100 SAD10012	3/4	*3DI-90 (Static < 0.6) *3DI-95 (Static > 0.6)	*110308 *110306-1	110240 (B77)
	1	*3DI-90 (Static < 0.4) *3DI-95 (Static > 0.4) 3DI-100 (Static < 0.4) 3DI-105 (Static > 0.4)	*110308 *110306-1 110309 110299	110240 (B77)
	1-1/2	*3DI-95 3DI-105	*110306-1 110299	110240 (B77)
SAD150 SAD15012	3/4	*3DI-130 (Static < 0.5) *3DI-135 (Static > 0.5)	*110308 *110306-1	110236 (B90)
	1	*3DI-130 (Static < 0.4) *3DI-135 (Static > 0.4) 3DI-140 (Static < 0.4) 3DI-145 (Static > 0.4)	*110308 *110306-1 110309 110299	110236 (B90)
	1-1/2	*3DI-135 (Static < 0.9) *3DI-156 (Static > 0.7) 3DI-145 (Static < 0.9) 3DI-155 (Static > 0.7)	*110306-1 *110310 110299 110307-1	110236 (B90)
	2	3DI-145 (Static < 0.8) 3DI-155 (Static > 0.5)	110299 110307-1	110236 (B90)
	3	3DI-161	110300	110250 (B92)
AD100 AD10012	1-1/2	*3DI-11 3DI-10	*110306 110299-1	110234 (A76)
	2	3DI-15	110299-1	110240 (B77)
	3	3DI-20	110300-1	110241 (B80)
	5	3DI-25	110303-1	110242 (B81)
AD150 AD15012	2	3DI-50 (Static < 0.7) 3DI-52 (Static > 0.5)	110302-1 110299-1	110236 (B90)
	3	3DI-56	110304-1	110250 (B92)
	5	3DI-60	110300-1	110246 (B93)
	7-1/2	3DI-65	110301-1	110237 (B95)
AD20012	3	3DI-195	110291	110248 (B100)
	5	3DI-200	110311-1	110248 (B100)
	7-1/2	3DI-203	110313	110249 (B103)
	10	3DI-205	110312-1	110249 (B103)
AU20012	3	3DI-225	110291	110250 (B92)
	5	3DI-230	110311-1	110250 (B92)
	7-1/2	3DI-233	110313	110246 (B93)
	10	3DI-235	110312-1	110246 (B93)

Model Modelo	HP C.V.	Pulley-Belt Kit Equipo Del Polea y Correa	Motor Pulley Polea De Motor	Drive Belt Correa
SAS100 SAS10012	3/4	*3DI-110 (Static < 0.6) *3DI-115 (Static > 0.6)	*110308 *110306-1	110243 (B83)
	1	*3DI-110 (Static < 0.4) *3DI-115 (Static > 0.4) 3DI-120 (Static < 0.4) 3DI-125 (Static > 0.4)	*110308 *110306-1 110309 110299	110243 (B83)
	1-1/2	*3DI-115 3DI-125	*110306-1 110299	110243 (B83)
SAS150 SAS15012	3/4	*3DI-165 (Static < 0.5) *3DI-170 (Static > 0.5)	*110308 *110306-1	110247 (B96)
	1	*3DI-165 (Static < 0.4) *3DI-170 (Static > 0.4) 3DI-175 (Static < 0.4) 3DI-180 (Static > 0.4)	*110308 *110306-1 110309 110299	110247 (B96)
	1-1/2	*3DI-170 (Static < 0.9) *3DI-186 (Static > 0.7) DI-180 (Static < 0.9) 3DI-185 (Static > 0.7)	*110306-1 *110310 110299 110307-1	110247 (B96)
	2	3DI-180 (Static < 0.8) 3DI-185 (Static > 0.5)	110299 110307-1	110247 (B96)
	3	3DI-190	110300	110248 (B100)
AS100 AS10012	1-1/2	*3DI-31 3DI-30	*110306 110299-1	110235 (A82)
	2	3DI-35	110299-1	110243 (B83)
	3	3DI-40	110300-1	110244 (B86)
	5	3DI-45	110303-1	110245 (B87)
AS150 AS15012	2	3DI-70 (Static < 0.8) 3DI-72 (Static > 0.5)	110302-1 110299-1	110247 (B96)
	3	3DI-75	110304-1	110248 (B100)
	5	3DI-80	110300-1	110248 (B100)
	7-1/2	3DI-86	110301-1	110252 (B101)
AS20012	3	3DI-210	110291	110253 (B112)
	5	3DI-215	110311-1	110253 (B112)
	7-1/2	3DI-218	110313	110253 (B112)
	10	3DI-220	110312-1	110253 (B112)

\* For motors with 5/8 in. shaft. / Para los motores con el eje de 5/8 pulgadas.