

This Owner's Manual is provided and hosted by [Appliance Factory Parts](#).

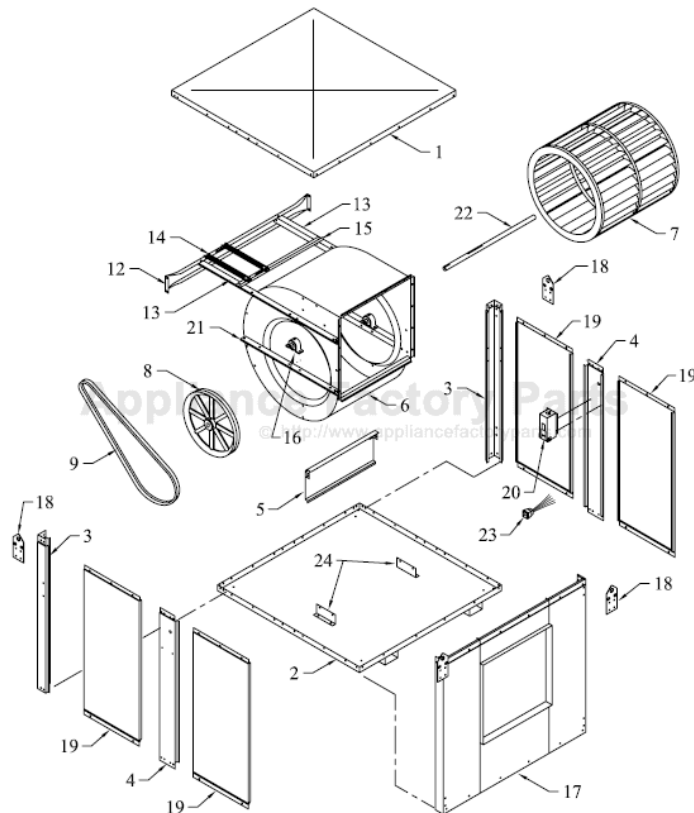

MASTERCool SAS150B Owner's Manual

[Shop genuine replacement parts for MASTERCool SAS150B](#)



[Find Your MASTERCool Evaporative Cooler Parts - Select From 135 Models](#)

----- Manual continues below -----

SPECIFICATIONS & SUBMITTAL DATA

FEATURES:

- Heavy gauge galvanized steel cabinet
- Electrostatically applied Polyester resin powder paint finish
- Thermoplastic water reservoir
- Long life media, efficient and self cleaning
- Greater air flow
- Low maintenance
- Made in the U.S.A.



Project _____

Location _____

Architect _____

Engineer _____

Contractor _____

Submitted By _____ Date _____

MODELS
SAS/SAD 100
SAS/SAD 150

Ref. No.	Cooler Model No.	Qty.	CFM	Static Pressure	Motor	HP	Speed	Volts	Phase	Pulley-Belt Kit No.	Pump	Qty.	Volts
1													
2													
3													
4													
5													
6													
7													
8													
9													

Notes

CHAMPION COOLER
 5800 Murray, Little Rock, AR 72209
 1-800-643-8341
 info@championcooler.com

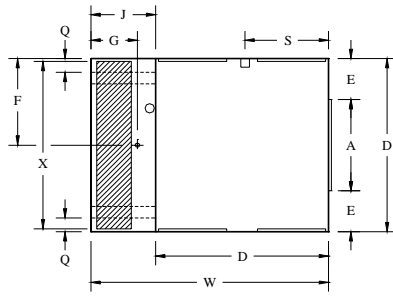

TOP VIEW

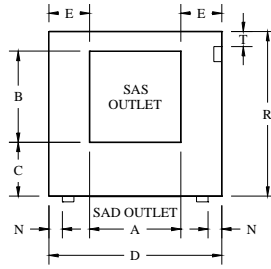

FRONT VIEW

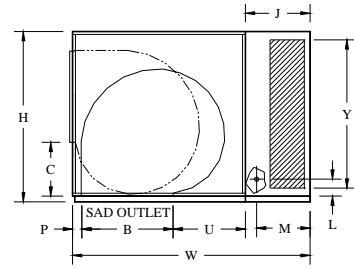

SIDE VIEW

DIMENSIONAL DATA*

BLOWER MODEL NUMBER	WET MUDULE NUMBER	CABINET			DUCT OPENING		DUCT LOCATION				DRAIN LOCATION			WET MODULE		MEDIA DIMENSION		WATER SERVICE		ELECTRIC SERVICE		SKID LOCATIONS		
		H	W	D	A	B	C (SAS)	U (SAD)	P (SAD)	E	F	G	J	X	Y	L	M	S	T	N	Q	R		
SAS/SAD 100B	100W	44	63 1/2	45	21 3/4	21 3/4	13 19/32	21 11/32	1 29/32	11 5/8	22 1/2	12 1/2	18 1/2	44 3/4	36 5/8	5 7/8	14 5/8	21 1/2	5 5/32	4 3/4	4 3/4	42		
SAS/SAD 150B	150W	54	66 3/4	48 1/4	26 7/8	26 7/8	16 15/16	19 5/32	2 7/32	10 11/16	24 1/8	12 1/2	18 1/2	48	46 3/8	5 7/8	14 5/8	23 1/8	5 5/32	4 3/4	4 3/4	52		

* All Measurements in inches.

SAS/SAD 100				PERFORMANCE Certified Air Delivery At .1" Increments Of External Static Pressure (Inches Static Pressure Water Gauge)																					
MAX B.H.P.	OPER. WGT.	SAD MODEL BELT	SAS MODEL BELT	0"		0.1"		0.2"		0.3"		0.4"		0.5"		0.6"		0.7"		0.8"		0.9"		1.0"	
				CFM	RPM	CFM	RPM	CFM	RPM	CFM	RPM	CFM	RPM	CFM	RPM	CFM	RPM	CFM	RPM	CFM	RPM	CFM	RPM	CFM	RPM
3/4	543	B77	B83	5377	352	5121	364	4863	376	4605	389	4336	402	4058	415	3754	430	3429	448	3097	469	NR	NR	NR	NR
1	546	B77	B83	5918	388	5684	398	5451	409	5215	421	4980	432	4734	444	4479	456	4209	470	3924	485	3619	503	3307	523
1 1/2	555	B77	B83	6774	444	6574	453	6366	463	6164	472	5956	482	5751	492	5537	502	5320	513	5095	524	4859	536	4613	548

SAS/SAD 150				PERFORMANCE Certified Air Delivery At .1" Increments Of External Static Pressure (Inches Static Pressure Water Gauge)																					
MAX B.H.P.	OPER. WGT.	SAD MODEL BELT	SAS MODEL BELT	0"		0.1"		0.2"		0.3"		0.4"		0.5"		0.6"		0.7"		0.8"		0.9"		1.0"	
				CFM	RPM	CFM	RPM	CFM	RPM	CFM	RPM	CFM	RPM	CFM	RPM	CFM	RPM	CFM	RPM	CFM	RPM	CFM	RPM	CFM	RPM
3/4	667	B90	B96	7072	275	6622	287	6203	298	5769	308	5298	321	4777	336	4201	355	3607	378	3041	402	2522	424	2040	443
1	670	B90	B96	7783	302	7372	314	6987	324	6602	333	6199	343	5764	355	5285	369	4764	386	4231	406	3699	427	3199	448
1 1/2	680	B90	B96	8910	346	8548	356	8205	365	7870	374	7533	382	7182	391	6812	401	6416	412	5993	424	5537	439	5067	456
2	686	B90	B96	N/A	N/A	9476	390	9159	399	8855	406	8555	414	8244	421	7924	430	7592	438	7236	448	6866	459	6470	471
3	696	B92	B100	N/A	N/A	N/A	N/A	N/A	N/A	N/A	N/A	N/A	N/A	N/A	N/A	N/A	N/A	9315	486	9032	493	8741	500	8436	509

Performance shown is for installation type B - Free inlet, Ducted outlet. Power rating (BHP) does not include drive losses.

PULLEY-BELT KIT SELECTION

H.P.	BORE	SAD 100 PULLEY-BELT KIT NO.	SAS 100 PULLEY-BELT KIT NO.	SAD 150 PULLEY-BELT KIT NO.	SAS 150 PULLEY-BELT KIT NO.
3/4	1/2	3DI-91 (Static < 0.5)	3DI-111 (Static < 0.5)	3DI-131 (Static < 0.5)	3DI-166 (Static < 0.5)
3/4	1/2	3DI-96 (Static > 0.5)	3DI-116 (Static > 0.5)	3DI-136 (Static > 0.6)	3DI-171 (Static > 0.6)
3/4	5/8	3DI-90 (Static < 0.5)	3DI-110 (Static < 0.5)	3DI-130 (Static < 0.5)	3DI-165 (Static < 0.5)
3/4	5/8	3DI-95 (Static > 0.5)	3DI-115 (Static > 0.5)	3DI-135 (Static > 0.6)	3DI-170 (Static > 0.6)
1	5/8	3DI-90 (Static < 0.2)	3DI-110 (Static < 0.2)	3DI-130 (Static < 0.4)	3DI-165 (Static < 0.4)
1	5/8	3DI-95 (Static > 0.2)	3DI-115 (Static > 0.2)	3DI-135 (Static > 0.4)	3DI-170 (Static > 0.4)
1	7/8	3DI-100 (Static < 0.2)	3DI-120 (Static < 0.2)	3DI-140 (Static < 0.4)	3DI-175 (Static < 0.4)
1	7/8	3DI-105 (Static > 0.2)	3DI-125 (Static > 0.2)	3DI-145 (Static > 0.4)	3DI-180 (Static > 0.4)
1 1/2	5/8	3DI-95	3DI-115	3DI-135 (Static < 0.9)	3DI-170 (Static < 0.9)
1 1/2	5/8	-	-	3DI-156 (Static > 0.7)	3DI-186 (Static > 0.7)
1 1/2	7/8	3DI-105	3DI-125	3DI-145 (Static < 0.9)	3DI-180 (Static < 0.9)
1 1/2	7/8	-	-	3DI-155 (Static > 0.7)	3DI-185 (Static > 0.7)
2	5/8	-	-	3DI-135 (Static < 0.7)	3DI-170 (Static < 0.7)
2	5/8	-	-	3DI-156 (Static > 0.3)	3DI-186 (Static > 0.3)
2	7/8	-	-	3DI-145 (Static < 0.7)	3DI-180 (Static < 0.7)
2	7/8	-	-	3DI-155 (Static > 0.3)	3DI-185 (Static > 0.3)
3	1 1/8	-	-	3DI-161	3DI-190

MOTOR SPECIFICATIONS

BLOWER MOTORS		VOLTS	PHASE	MOTOR AMPS*	SHAFT DIA.	MOTOR WGT(LB)	MOTOR PART NO.	BLOWER MOTORS		VOLTS	PHASE	MOTOR AMPS*	SHAFT DIA.	MOTOR WGT(LB)	MOTOR PART NO.
H.P.	SPEED							H.P.	SPEED						
3/4	1	115/208-230	1	13.8/7.6-6.9	5/8	24	110455	2	1	115/208-230	1	24/13.2-12	5/8	50	110460-1
3/4	2	230	1	6.9	1/2	21	110480	2	1	208-230/460	3	7.5-6.8/3.4	7/8	44	110464-9
3/4	1	208-230/460	3	3.5-3.2/1.6	5/8	20	110461	3	1	208-230/460	3	10.6-9.6/4.8	1 1/8	83	110465-9
1	1	115/230	1	16.8	5/8	28	110457								
1	2	230	1	8	5/8	29	110458								
1	1	208-230/460	3	4.6-4.2/2.1	7/8	34	110462-9								
1 1/2	1	115/208-230	1	20/11-10	5/8	41	110459-1								
1 1/2	1	208-230/460	3	6.6-6/3	7/8	40	110463-9								

* Amperage shown is from National Electrical Code. Use amperage shown on motor nameplate to determine motor protector.

Pumps - 1 Required.

PUMP PART NO.	VOLTS	AMPS	WATTS	GPM (SFT. HEAD)
110467	115	1.0	73	4.6
110468	230	0.58	77	4.6