

OWNER'S MANUAL
PACKAGED TERMINAL AIR CONDITIONERS
AND HEAT PUMPS
7,000-15,000 Btuh

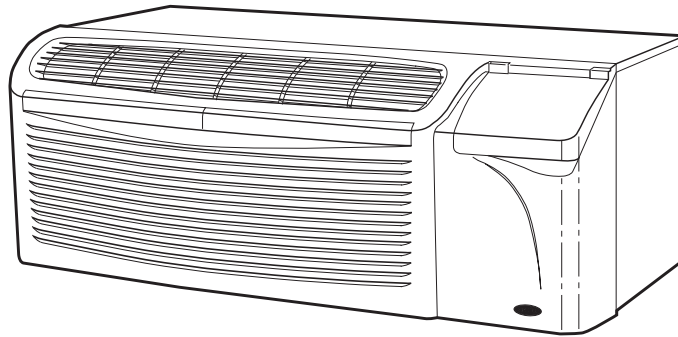

CONTENTS

	Page		Page
GENERAL	2	CARE AND MAINTENANCE	10,11
UNIT INSPECTION	2,3	INDOOR-AIR INLET FILTERS	10
FRONT PANEL	2	EXTERNAL PARTS	11
ELECTRICAL DATA	4	INTERNAL PARTS	11
ALL UNITS	4	PREVENTATIVE MAINTENANCE	12
VOLTAGE SUPPLY	4	TROUBLESHOOTING	13
INSTALLATION	5-7	ACCESSORIES	14
CHASSIS INSTALLATION	5		
WALL THERMOSTAT INSTALLATION	7		
OPERATION	8,9		
COMFORT CONTROLS	8		
OPERATING CONTROLS	9		
OPERATING MODES	9		

1•800•894•6449
For Service/
Technical Assistance

52C SERIES

GENERAL

Thank you for choosing Carrier! You can feel confident in your selection because the same pride in craftsmanship and engineering knowledge that goes into Carrier equipment at the Astrodome in Texas, the Sistine Chapel in Rome, the US Capitol Hall of Congress, and thousands of other installations worldwide has gone into the construction of this unit.

The Carrier package terminal air conditioners and heat pumps provide a high standard of quality in performance, workmanship, durability and appearance as they heat and cool the occupied air space year round.

This manual provides information for ease of installation, operation and maintenance of the 52C unit. The following units are covered in this manual (see Figure 1 for additional unit information):

52CE 60 Hz cooling with electric heat units
52CQ 60 Hz cooling, electric heat, and heat pump units

All models are designed for through-the-wall installation. Separate installation instructions are included with all accessory components. See Accessories section on page 14 for complete listing of accessories.



MODEL	52CQA312301AA		
SERIAL	0201X11520		
DATE OF MFG.	01/12/2001		
VOLT RANGE	187-253		
VOLTS	230/208		
PH	1	HZ	60
MIN CKT AMPACITY	17.9		
R-22 OZ	34		
DESIGN PSIG	350 HIGH SIDE, 150 LOW SIDE		
COOLING			
BTU/HR	12,000/11,900		
AMPS	5.8/6.2		
WATTS	1333/1311		
EER	10.1/10.1		
COMP	RLA	70	
	LRA	33.2	
FAN	FLA	1.0/0.8	
MOTOR	HP	1/8	
HEATING			
BTU/HR	10,800/10,700		
AMPS	15.8/14.5		
WATTS	3600/3025		
COP	3.0/3.0		
HEATER	AMPS	14.8/13.7	
	WATTS	3400/2850	
BTU/HR	WATER		
	STEAM		
USE	20 AMP	CANADIAN INSTALLATION	
TIME DELAY FUSE		MAX FUSE	MAX BREAKER
OR HACR TYPE		20 AMP	20 AMP
CIRCUIT BREAKER			
ABOVE DATA FOR PERMANENTLY CONNECTED UNIT ONLY			
MOTOR - COMPRESSOR THERMALLY PROTECTED			
  			
CARRIER Corporation			
MADE IN MEXICO 99LR520212 REV D			
TELEPHONE			
1-800-894-6449			
FOR			
SERVICE/TECHNICAL			
ASSISTANCE			

FIGURE 1 — SAMPLE DATA INFORMATION PLATE

UNIT INSPECTION

Examine unit for damage incurred during shipment. File a claim immediately with the transit company if damage is found.

The data information plate (Figure 1) lists the model number, voltage ranges, and other important electrical information about this product. Reading and understanding this material is important for proper use of this unit. To access the information plate, the front panel must be removed; see Figure 2.

FRONT PANEL

To remove the front panel:

1. Grasp panel firmly near bottom of both sides.
2. Pull panel forward then upward to release magnetic latches and partition hooks.

NOTE: Front panel may be secured to chassis with 2 screws located behind indoor air inlet filters. In order to remove these screws, the filters must be removed first. Refer to page 10 in this manual for instructions on removing indoor air inlet filters.

IMPORTANT: The front panel has to be off the unit to complete future checks and installation procedures. **Do not reinstall front panel at this time.**

Using Figures 1 and 3 as reference, verify that the packaged terminal product ordered will operate properly in your facility. If you do not understand the information given or have questions about the product, please call your local dealer or distributor.

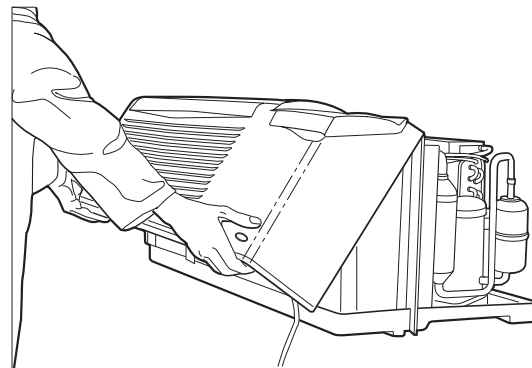

FIGURE 2 — REMOVING FRONT PANEL

Replacement Package Terminal Air Conditioner, CLASSIFIED BY UNDERWRITERS LABORATORIES INC., AS TO ELECTRIC SHOCK, FIRE AND CASUALTY HAZARDS ONLY. FOR FIELD INSTALLATION WITH EXISTING WALL SLEEVES, OUTDOOR LOUVERS, AND INDOOR PANELS AS SPECIFIED ON THE PRODUCT.



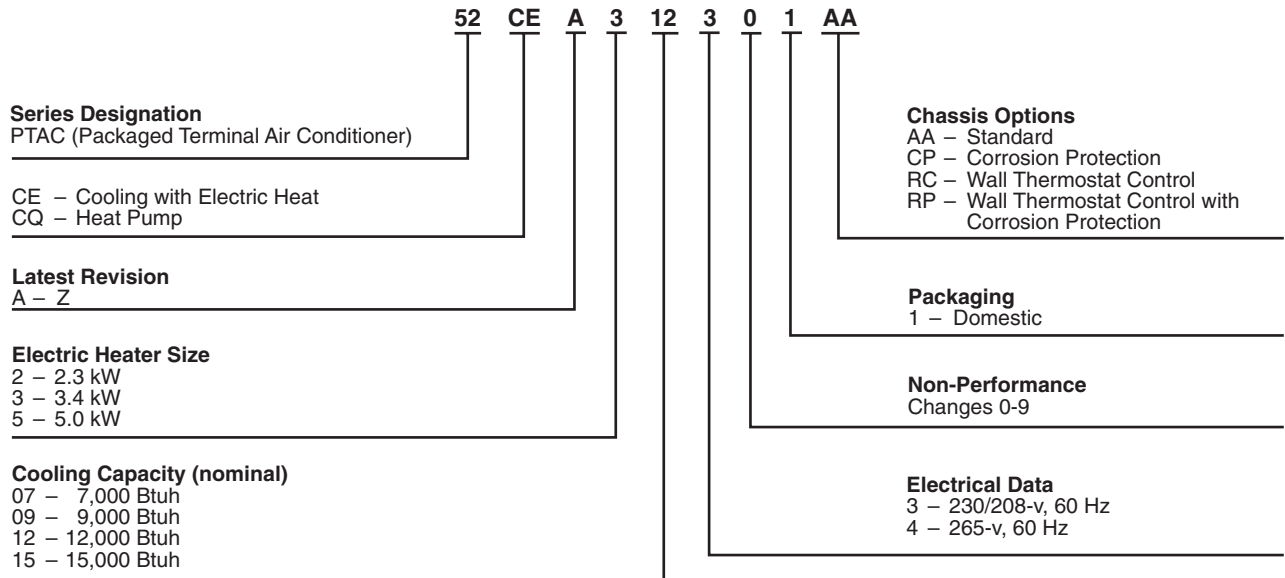

FIGURE 3 — MODEL NUMBER NOMENCLATURE

To install the front panel follow the procedure outlined below:

1. Firmly grasp bottom of front panel on both sides.
2. Hold front panel at a 45 degree angle to unit. Be sure front panel is centered with front of unit.
3. Connect top of front panel to partition rail on top of unit.
4. Gently lower front panel onto chassis, ensuring service cord is positioned through front panel slot.

NOTE: Magnets on bottom of front panel will secure front panel to unit.

To install locking feature on front panel be sure front panel is already installed on unit and follow the steps below:

NOTE: Two field-supplied no. 8, 1/2 in. sheet metal screws are required to secure front panel to chassis.

1. Remove both indoor air inlet filters to expose front panel engagement holes. See Figure 4.
2. Secure front panel to chassis by attaching the field-supplied screws into engagement holes. *Do not over tighten.*
3. Replace both indoor air inlet filters.

NOTE: Front panel alignment may have to be adjusted slightly to line with chassis.

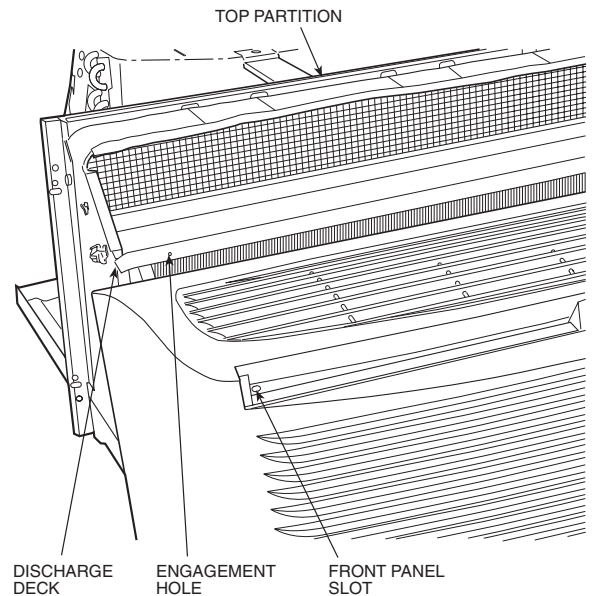

FIGURE 4 — FRONT PANEL INSTALLATION WITH LOCKING FEATURE

52C SERIES

ELECTRICAL DATA

▲ WARNING

ELECTRICAL SHOCK HAZARD

DO NOT alter cord or plug, and DO NOT use an extension cord. Personal injury or damage to the unit may result.

Be sure that your outlet matches the appropriate blade configuration of the supplied plug and that it is within reach of the service cord. A hardwire kit is available as an accessory to change cord-connected units to hardwired units. (See Accessories section, page 14.)

IMPORTANT: All standard cord-connected 265-v units will require a field-installed electrical sub-base accessory.

ALL UNITS

■ **WIRE SIZE** — Use recommended wire size given in Table 1 and install a single branch circuit. All wiring must comply with local and national codes. **All units are designed to operate off single branch circuits only.**

NOTE: Use copper conductors only.

■ **GROUNDING** — For safety and protection, the unit is grounded through the service cord plug or through separate ground wire provided on hardwired units. Be sure that the branch circuit or general purpose outlet is grounded.

TABLE 1 — SUGGESTED BRANCH CIRCUIT WIRE SIZES*

NAMEPLATE AMPS	AWG WIRE SIZE†
7.0 to 12	14
12.1 to 16	12
16.1 to 24	10

LEGEND

AWG — American Wire Gage

*Single circuit from main box.







†Based on copper wire at 60 C temperature rating.

VOLTAGE SUPPLY

Check voltage supply at outlet. For satisfactory results, the voltage range must always be within the ranges found on the data information plate (Figure 1).

■ **CORD-CONNECTED UNITS** — The 250-v field-supplied outlet must match the plug for the standard 208/230-v units and be within reach of the service cord. The standard cord-connected 265-v units require an accessory electrical subbase for operation. See Accessories section, page 14, for subbase selection. Refer to Table 2 for proper receptacle and fuse type.

TABLE 2 — RECEPTACLES AND FUSE TYPES — 250,265 VOLTS

RECEPTACLE						
	15 Amps	20 Amps	30 Amps	15 Amps	20 Amps	30 Amps
RATED VOLTS	250	250	250	265	265	265
TIME-DELAY TYPE FUSE (or HACR Circuit Breaker)	15	20*	30	15	20	30

LEGEND

HACR — Heating, Air Conditioning, Refrigeration

*May be used for 15-amp applications if fused for 15 amp.

INSTALLATION

CHASSIS INSTALLATION

Units are shipped without a sleeve. In applications where unit is a replacement, it is recommended that a Carrier sleeve be used. The 52C unit can retrofit General Electric, Amana and Trane sleeves/grilles (be sure outdoor grille is installed on the sleeve). A retrofit kit with instructions is included with every unit. See Table 3 for details. Carrier Corporation must approve any other retrofit application. In deep-wall applications, if an existing grille is used on an outdoor wall opening, *do not* install an additional outdoor grille on unit sleeve.

Be sure that the foam strips and/or baffles provide a good seal between the grille and condenser coil tube sheets. These foam strips or baffles provide a barrier to separate condenser air from the major components (compressor and fan motor). See Figures 5 to 8.

NOTE: Inspect wall sleeve for any damage or deterioration before installing chassis.

⚠ CAUTION

If baffles are not installed properly, loss of performance and premature damage to the major components can result.

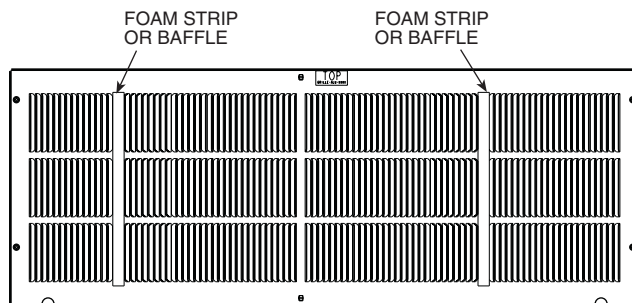

FIGURE 5 — OUTDOOR GRILLE

TABLE 3 — RETROFIT WALL SLEEVES

MANUFACTURER*	WALL SLEEVE PART NUMBER
General Electric	Metal Sleeve RAB71
	Plastic Sleeve RAB77
Amana	Metal Sleeve WS900B
Trane	Metal Sleeve SLV149

*Retrofit kit is *not* needed for Carrier or Bryant applications.

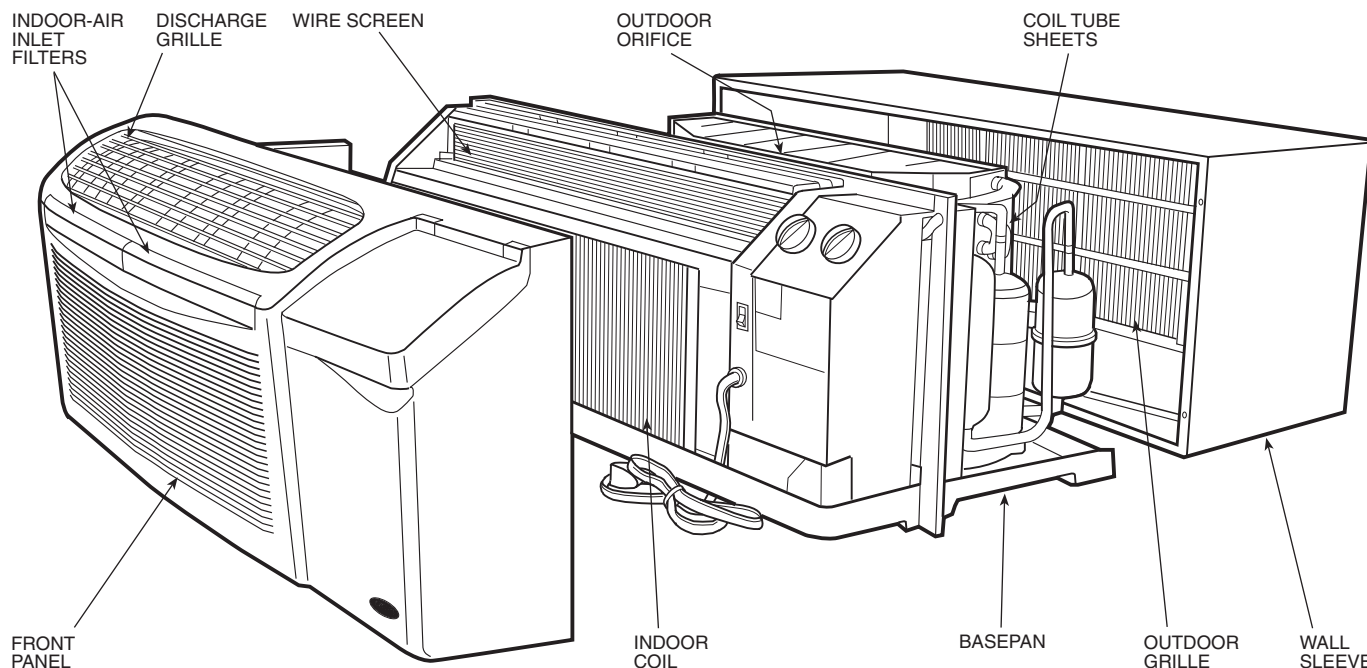

FIGURE 6 — 52C UNIT COMPONENTS

52C SERIES

■ INSTALL CHASSIS IN SLEEVE (See Figures 6 to 9)

1. Inspect foam gaskets (top, bottom, both sides) on chassis. Replace foam gaskets if torn or missing.

IMPORTANT: The gaskets combine with the sleeve face to create a weather barrier. If the chassis is installed in a non-Carrier sleeve, this weather barrier may not be effective.

⚠ WARNING

Chassis weighs up to 150 lbs. For personal protection, seek help when lifting the unit. Lift unit by holding unit basepan.

2. Remove shipping tape from vent door. See Figure 7.

⚠ CAUTION

Failure to remove shipping tape will prevent fresh air vent door from opening and may result in damage to the vent door cable.

3. Lift chassis level with wall sleeve.
4. Slide chassis into wall sleeve until foam gaskets rest firmly against front of wall sleeve.
5. Screw chassis to wall sleeve with four 1³/₄-in. long screws taped to the control box. Screw holes are located on both sides of the mounting angles of the chassis. Use only the top and bottom screw holes on each side. See Figure 9.

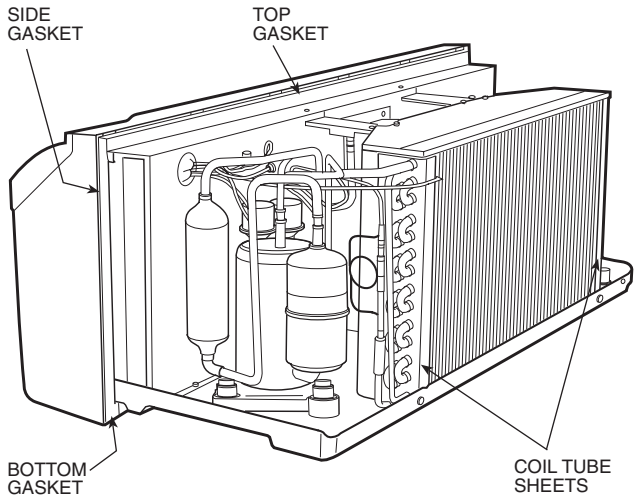

FIGURE 8 — 52C UNIT GASKETS AND TUBE SHEETS

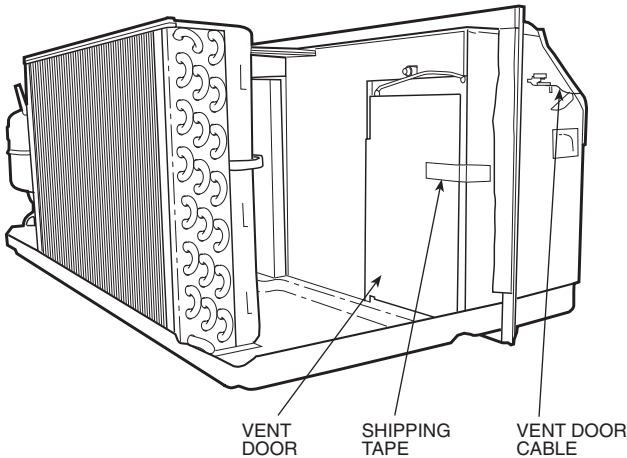

FIGURE 7 — LOCATION OF SHIPPING TAPE ON VENT DOOR

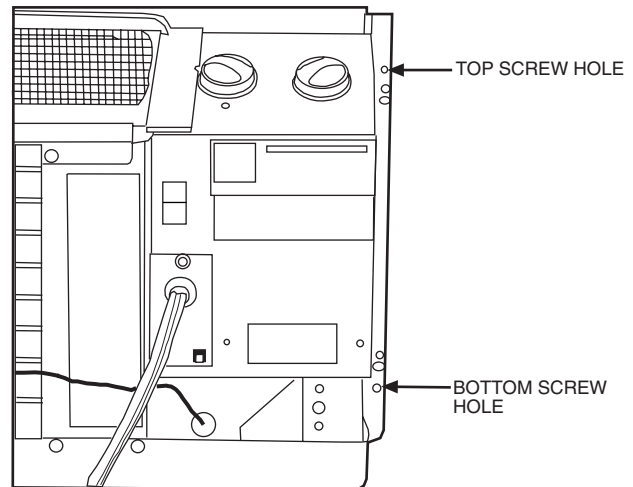

FIGURE 9 — CHASSIS MOUNTING

WALL THERMOSTAT INSTALLATION

The following instructions apply to RC and RP units only.

NOTE: Carrier thermostats are recommended. See Accessories section.

IMPORTANT: Only trained, qualified personnel and service mechanics should install electrical accessories on Carrier 52C series products per Carrier's installation instructions. Please contact your local electrical contractor, dealer, or distributor for assistance.

■ INSTALL THERMOSTAT — All remote control units.

1. Check to be sure power to unit is disconnected.
2. Remove terminal board cover from control box cover by removing screw (see Figure 10).

NOTE: Terminal connector can be removed and replaced to simplify thermostat wiring.

3. Connect wires from terminals on the thermostat to terminals on chassis terminal board connector. See Figures 11 and 12.

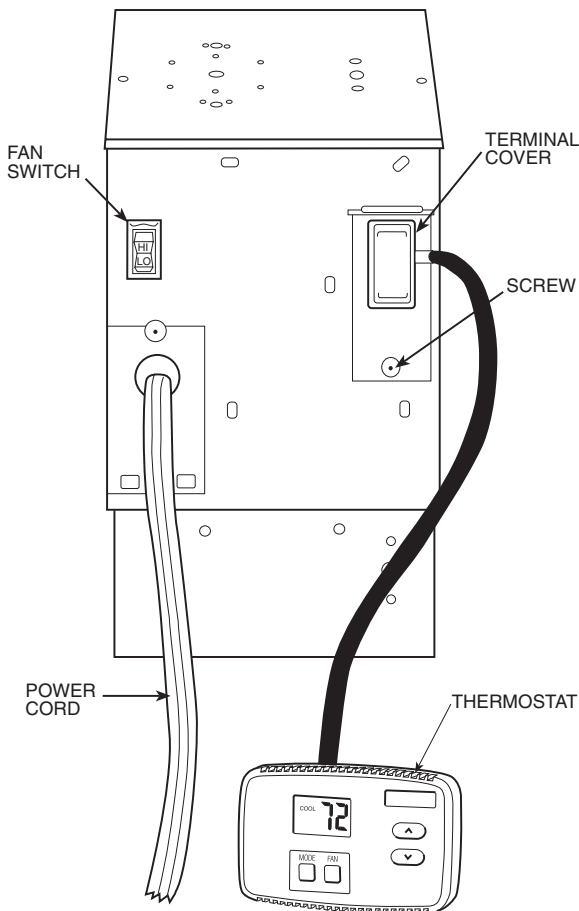
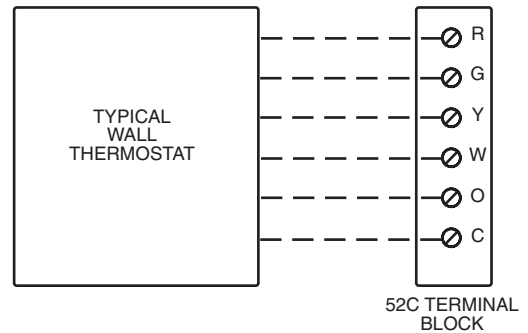

FIGURE 10 — CONTROL BOX TERMINAL COVER

4. Reinstall cover.
5. Set desired fan speed using fan switch (unit will operate only at selected speed).
6. Restore power to unit.

NOTE: Refer to thermostat installation instructions for details on installing thermostat.



NOTES:

1. Use terminal "O" for heat pump connection only.
2. See table below for terminal descriptions.

TERMINAL	DESIGNATION
R	24 VAC
G	Fan
Y	Compressor
W	Electric Heat
O	Reversing Valve
C	Common

FIGURE 11 — WIRING CONNECTIONS

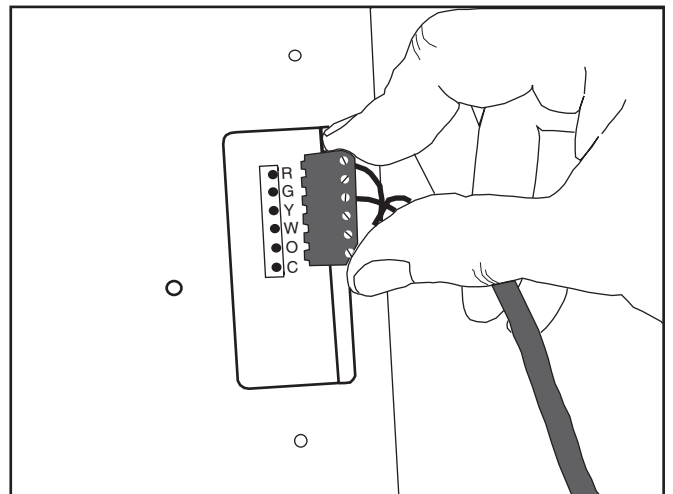

FIGURE 12 — TERMINAL CONNECTOR REMOVAL AND REPLACEMENT

52C SERIES

OPERATION

COMFORT CONTROLS

■ **ADJUST AIRFLOW DIRECTION** — The discharge air grille is mounted on the front panel so that the air discharges forward. If upward discharge is required, remove the grille by removing screws on back of front panel. Rotate grille 180 degrees and reinstall on the front panel.

■ **ADJUST VENT** — The vent handle is on the left side of the unit. Turn handle to open or close vent. Vent will remain in last desired position until handle is turned again. Magnet will ensure positive closure. See Figure 13.

■ **SETTING TEMPERATURE LIMITS** — Setting temperature limits on the unit provides the user a restricted range of temperature control. See Figure 14. **NOTE:** This adjustment is optional and is not applicable to remote control units.

The temperature limits are factory set to full range, which is 60 F to 90 F. To set restricted rotation of the temperature control knob:

1. Remove front panel.
2. Remove temperature control knob to expose temperature limiter.
3. Remove standoff pins from the 60 F and 90 F indicator holes.
4. Replace standoff pin in hole for desired minimum temperature.
5. Replace standoff pin in hole for desired maximum temperature.
6. Reinstall temperature control knob.
7. Reinstall front panel.

NOTE: Temperature indicators stamped on temperature limiter are approximate and represent degrees F.

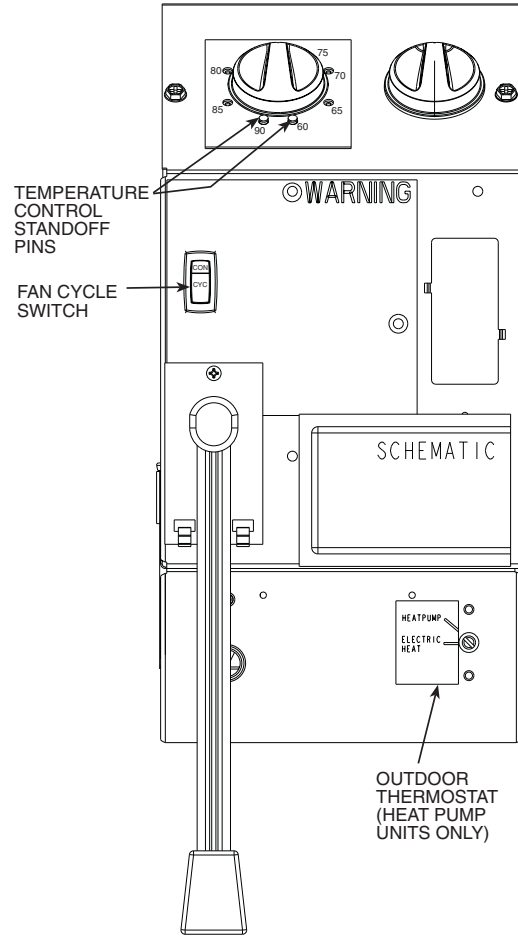

FIGURE 14 — 52C OPERATING CONTROLS

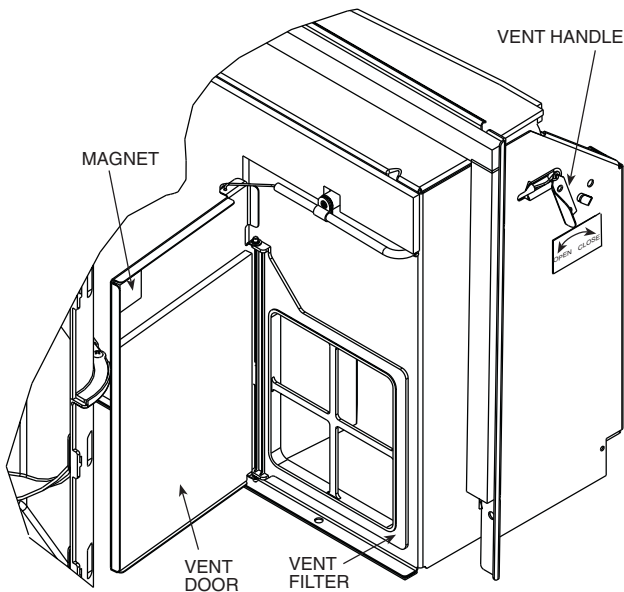

FIGURE 13 — 52C VENT DOOR

OPERATING CONTROLS

The following controls are located on the front of the chassis. To obtain access to operating controls, remove the unit front panel as shown on page 2. See Figure 14.

IMPORTANT: When unit is first started, high humidity conditions can cause condensation to form on discharge grille. Keep doors and windows closed. Room humidity decreases and moisture evaporates.

■ **FAN CYCLE SWITCH** — (Not available on RC or RP units.) This allows the fan to operate in two modes:

CON (Continuous) — This setting allows the fan to run continuously, circulating air even when the temperature setting has been satisfied. This switch helps to maintain the room temperature closer to the thermostat setting. Use this switch position when maximum comfort is desired. This is the factory default setting.

CYC (Cycle) — This setting allows the fan to cycle on and off with the compressor during heating or cooling. The fan stops when the temperature setting is satisfied. This results in longer unit off-time and wider variations in room temperature and humidity.

■ **OUTDOOR THERMOSTAT (52CQ HEAT PUMP UNITS ONLY)** — If the setscrew is left at the factory setting (in the heat pump position), the unit will operate in the reverse cycle heating mode. When the temperature of the outdoor coil reaches 20° F (approximately 35° F outdoor air temperature), the compressor will shut down. The electric heater remains on until the temperature of the outdoor coil reaches 35° F

(approximately 45° F outdoor air temperature); then the electric heater is shut off and the compressor is energized.

IMPORTANT: Once in electric heat mode, the compressor is disabled for heating and cooling.

To set unit to operate in electric heat mode only, turn the setscrew to the electric heat position.

OPERATING MODES (See Figures 15 and 16.)

■ **OUTSIDE AIR** — To bring outside air into occupied space, turn the vent handle to the full open position. See Figure 13.

■ **OFF** — The OFF mode terminates unit operation.

■ **FAN** — The FAN mode will circulate air in the space at high speed.

■ **HIGH HEAT OR HIGH COOL** — Select mode and rotate temperature knob to desired comfort level. This function provides maximum heating or cooling, and is recommended to raise or lower the room temperature quickly.

■ **LOW HEAT OR LOW COOL** — Select mode and rotate temperature knob to desired comfort level. This function provides minimum heating or cooling with maximum dehumidification and quietest operation.

NOTE: 52C wall thermostat units have a blank plate. See Figure 14.

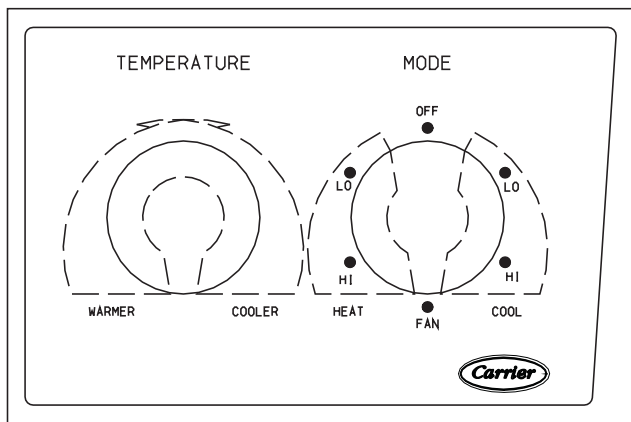

FIGURE 15 — 52C UNIT CONTROLS

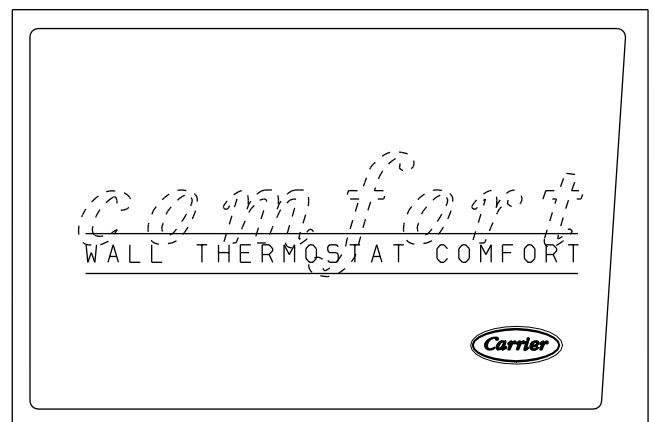

FIGURE 16 — 52C UNIT WITH WALL THERMOSTAT CONTROL (Blank Plate)

CARE AND MAINTENANCE

In order to maintain proper performance of your packaged terminal air conditioner or heat pump, it is very important that the fan and outdoor coil, the blower wheel, blower scroll, electric heater, and all drain passages are thoroughly cleaned at least once per year. Carrier recommends that as a minimum, the cleaning should be conducted prior to the start of each heating season. The air inlet filters should be cleaned every month.

Depending on local conditions, more frequent cleaning of the unit may be required to ensure optimum performance and long operating life. Examples of these special conditions include areas where construction dust or heavy airborne dirt is found, or environments that promote the growth of fungus.

▲ CAUTION

Some local conditions and environments can cause fungi to grow inside the air conditioner, especially on indoor blower section. Dried fungi, dirt and other foreign material are fire hazards. Be sure to clean unit according to the instructions that follow.

INDOOR-AIR INLET FILTERS

■ **INDOOR-AIR INLET FILTERS** should be cleaned once each month.

IMPORTANT: Filters may become clogged if not cleaned properly. Clogged filters will restrict airflow which may lead to severe component damage and efficiency loss.

■ **CLEANING INDOOR-AIR INLET FILTER** — Two interchangeable air filters are located on the backside of the front panel. Each can be removed and cleaned one at a time. To remove and clean the filter, follow the steps below:

1. Grasp filter with both hands.
2. Gently pull the filter up and away from the unit. See Figures 6 and 17.
3. To clean filter, use a vacuum or soft bristle brush with a small amount of mild detergent.

NOTE: If detergent is used, remove any detergent residual with a gentle stream of clean water.

4. Allow filters to air dry.
5. Re-insert dry filters back into front panel.

Additional filters are available in multi-packs. Refer to Accessories section.

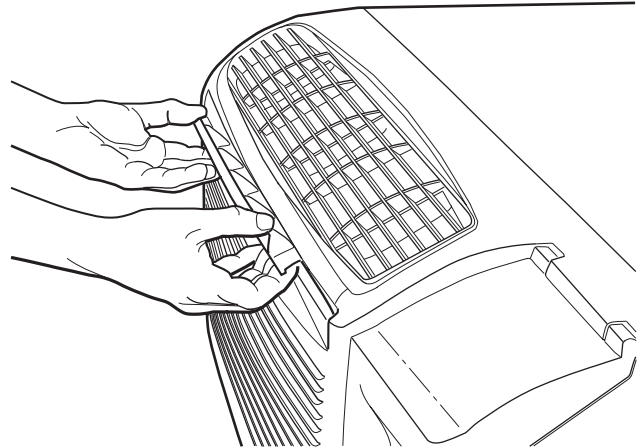

FIGURE 17 — 52C INDOOR-AIR INLET FILTER REMOVAL

EXTERNAL PARTS

■ **EXTERNAL PARTS** include the polymer sleeve and grilles. The sleeve manufacturer recommends cleaning the surface, including the grilles, with household detergent and water.

INTERNAL PARTS

■ **INTERNAL PARTS** should be cleaned at least once during the year. The outdoor vent filter should be cleaned at least once during a cooling or heating season.

Internal parts that should be cleaned include the following (see Figures 6, 18, and 19):

- Outdoor vent filter
- Basepan
- Outdoor orifice and fan
- Indoor and outdoor refrigeration coils
- Indoor blower wheel
- Wire screen
- Scroll
- Wall sleeve internal surfaces
- Outdoor grille

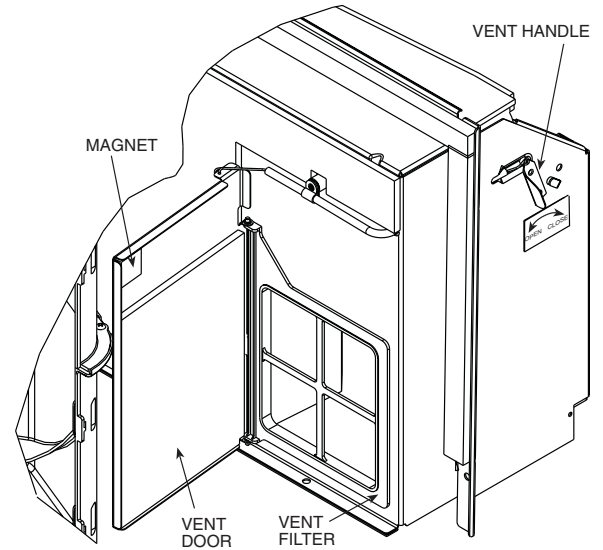

**FIGURE 18 — OUTDOOR VENT FILTER
(Left Side of Chassis)**

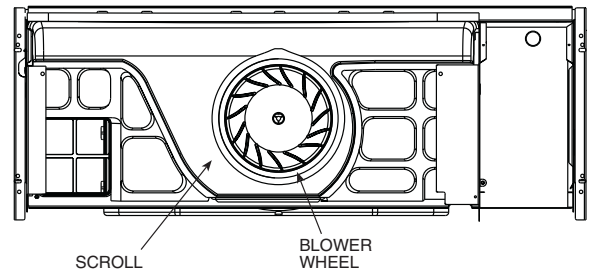

FIGURE 19 — BLOWER WHEEL AND SCROLL

PREVENTATIVE MAINTENANCE

Preventative maintenance is essential to proper unit operation, efficiency and longevity. To assure equipment operates properly it must be properly maintained. Equipment operation should be checked and verified several times during each year.

During regular unit inspection and maintenance, follow the guidelines below:

- Wash both sides of outdoor coil
- Wash basepan and outdoor vent filter
- Wash the indoor coil
- Clean the blower wheel and front panel
- Clean or install new indoor-air inlet filter(s)
- Ensure knobs are secure and operable
- Inspect cord and receptacle
- Secure electrical connections
- Ensure front panel is properly mounted and not damaged
- Ensure wall sleeve is installed properly
- Ensure heat and cool cycles operate properly

TROUBLESHOOTING

POSSIBLE CAUSES	SOLUTIONS
UNIT DOES NOT START <ul style="list-style-type: none"> • Unit may have become unplugged • Fuse may have blown • Circuit breaker may have been tripped • Unit mode dial may be set to the OFF position 	<ul style="list-style-type: none"> • Check that plug is securely in wall receptacle. • Replace the fuse. See Note 1. • Reset circuit breaker. See Note 1. • Switch mode dial to an operating mode.
UNIT NOT COOLING/HEATING ROOM <ul style="list-style-type: none"> • Unit air discharge section is blocked • Temperature setting is not high or low enough • Unit air filters are dirty • Room is excessively hot or cold when unit is started • Vent door left open 	<ul style="list-style-type: none"> • Make sure that curtains, blinds or furniture are not restricting or blocking unit airflow. • Reset to a lower or higher temperature setting. • Remove and clean filters. • Allow sufficient amount of time for unit to heat or cool the room. Start heating or cooling early before outdoor temperature, cooking heat or gatherings of people make room uncomfortable. • Close vent door.
UNIT MAKING NOISES	<ul style="list-style-type: none"> • Clicking, gurgling and whooshing noises are normal during operation of unit.
WATER DRIPPING OUTSIDE	<ul style="list-style-type: none"> • If a drain kit has not been installed, condensation run-off during very hot and humid weather is normal. See Note 2. If a drain kit has been installed and is connected to a drain system, check gaskets and fittings around drain for leaks and plugs.
WATER DRIPPING INSIDE <ul style="list-style-type: none"> • Wall sleeve is not installed level 	<ul style="list-style-type: none"> • Wall sleeve must be installed level for proper drainage of condensation. Check that installation is level and make any necessary adjustments.
ICE OR FROST FORMS ON INDOOR COIL <ul style="list-style-type: none"> • Low outdoor temperature • Dirty filters 	<ul style="list-style-type: none"> • When outdoor temperature is approximately 55 F or below, frost may form on the indoor coil when unit is in Cooling mode. Switch unit to FAN operation until ice or frost melts. • Remove and clean filters.

NOTES:

1. If circuit breaker is tripped or fuse is blown more than once, contact a qualified electrician.
2. If unit is installed where condensation drainage could drip in an undesirable location, an accessory drain kit should be installed and connected to drain system.

52C SERIES

ACCESSORIES

ACCESSORY	FORM NUMBER	PART NUMBER	DESCRIPTION	
Wall Sleeves	52S-48SI	WALL-SLEEVE-1PK WALL-SLEEVE-9PK SLEEVE-INSUL-1PK	Non-Insulated Plastic Wall Sleeve, 1 per pack Non-Insulated Plastic Wall Sleeve, 9 per pack Insulated Plastic Wall Sleeve, 1 per pack	
	52S-50SI	SLEEVE-STEEL-1PK	Insulated Metal Wall Sleeve, 1 per pack	
	52S-49SI*	SLEEVE-EXT24-1PK	Extended Metal Wall Sleeve for Deep Wall Applications (24 in. deep), 1 per pack	
Exterior Grilles†	52S-59SI	GRILLE-ALU-STAMP	Stamped Aluminum Exterior Grille, Clear Finish	
	52S-58SI	GRILLE-PLA-BROWN GRILLE-PLA-BEIGE	Plastic Architectural Rear Grille, Brown Plastic Architectural Rear Grille, Beige	
	52S-60SI	GRILLE-ALU-CLEAR GRILLE-ALU-WHITE GRILLE-ALU-BRONZ GRILLE-ALU-MBRNZ GRILLE-ALU-BROWN GRILLE-ALU-BEIGE GRILLE-ALU-ALPIN GRILLE-ALU-PEACH GRILLE-ALU-MELON GRILLE-ALU-LGREY GRILLE-ALU-SGREY GRILLE-ALU-RDBRK GRILLE-ALU-BLUE GRILLE-ALU-GREEN	Aluminum Architectural Exterior Grille, Clear Finish Aluminum Architectural Exterior Grille, White Aluminum Architectural Exterior Grille, Light Bronze Aluminum Architectural Exterior Grille, Medium Bronze Aluminum Architectural Exterior Grille, Brown (Dark Bronze) Aluminum Architectural Exterior Grille, Beige Aluminum Architectural Exterior Grille, Alpine (matches Carrier Wall Sleeve) Aluminum Architectural Exterior Grille, Peach Aluminum Architectural Exterior Grille, Melon Aluminum Architectural Exterior Grille, Light Grey Aluminum Architectural Exterior Grille, Slate Gray Aluminum Architectural Exterior Grille, Red Brick Aluminum Architectural Exterior Grille, Blue Aluminum Architectural Exterior Grille, Green	
	52C,P-1SI	SUBBASE-NON-ELEC	Non-electrical Subbase	
Subbase	52C,P-2SI	SUBBASE-230V-15A SUBBASE-230V-20A SUBBASE-230V-30A SUBBASE-265V-15A SUBBASE-265V-20A SUBBASE-265V-30A	Electrical subbase with factory-installed 208/230V, 15 amp receptacle Electrical subbase with factory-installed 208/230V, 20 amp receptacle Electrical subbase with factory-installed 208/230V, 30 amp receptacle Electrical subbase with factory-installed 265V, 15 amp receptacle Electrical subbase with factory-installed 265V, 20 amp receptacle Electrical subbase with factory-installed 265V, 30 amp receptacle	
	52C,P-3SI	SUBBASE-HARDWIRE	Electrical subbase with factory-installed hardwire kit (230/208V and 265V)	
	Subbase Field-Installed Kits	52C,P-8SI	SUBBASE-HW-KIT	Subbase Hardwire Kit, to make a non-electrical subbase, hardwired in the field (230/208V and 265V)
		52C,P-6SI	RECEPT-230V-15A	Subbase 208/230V, 15 amp Receptacle Kit, to add a receptacle to a non-electrical subbase in the field
			RECEPT-230V-20A	Subbase 208/230V, 20 amp Receptacle Kit, to add a receptacle to a non-electrical subbase in the field
RECEPT-230V-30A			Subbase 208/230V, 30 amp Receptacle Kit, to add a receptacle to a non-electrical subbase in the field	
RECEPT-265V-15A			Subbase 265V, 15 amp Receptacle Kit, to add a receptacle to a non-electrical subbase in the field	
RECEPT-265V-20A			Subbase 265V, 20 amp Receptacle Kit, to add a receptacle to a non-electrical subbase in the field	
RECEPT-265V-30A	Subbase 265V, 30 amp Receptacle Kit, to add a receptacle to a non-electrical subbase in the field			
52C,P-4SI	SUBBASE-SWITCH	Field-Installable Switch kit for an electrical subbase		
52C,P-5SI	SUBBASE-FUSE-15A SUBBASE-FUSE-20A SUBBASE-FUSE-30A	Field-Installed Fuse Kit (15 amp) for electrical subbase Field-Installed Fuse Kit (20 amp) for electrical subbase Field-Installed Fuse Kit (30 amp) for electrical subbase		
Electrical Connections	52C,P-11SI	HARDWIRE-KIT-1PK	Permanent power connection to the unit (includes 36" of flexible conduit and unit-mounted connector, 230/208V and 265V) 1 per pack	
Condensate Drain Kit	52S-53SI	DRAIN-KIT-4PK	Attaches to wall sleeve for controlled internal or external disposal of condensate 4 per pack	
Wall Thermostats	N/A	HH01AD045 TSTATCCBPC01-B TSTATCCBPH01-B TSTATCCPAC01-B TSTATCCPHP01-B	Electro-mechanical Wall Thermostat (Heat/Cool and Heat Pump) Value Series Electronic Thermostat w/Digital display (Heat/Cool Models) Value Series Electronic Thermostat w/Digital display (Heat Pump Models) 7-Day Programmable Electronic Thermostat (Heat/Cool Models) 7-Day Programmable Electronic Thermostat (Heat Pump Models)	
Wall Thermostat Interface Retrofit Kit	52C,P-7SI	RC-FIELDKIT230HC RC-FIELDKIT230HP RC-FIELDKIT265HC RC-FIELDKIT265HP	Field-installed wall thermostat retrofit kit to convert a standard 230V Heat/Cool unit to an RC unit. Wall thermostat sold separately. Field-installed wall thermostat retrofit kit to convert a standard 230V Heat Pump unit to an RC unit. Wall thermostat sold separately. Field-installed wall thermostat retrofit kit to convert a standard 265V Heat/Cool unit to an RC unit. Wall thermostat sold separately. Field-installed wall thermostat retrofit kit to convert a standard 265V Heat Pump unit to a RC unit. Wall thermostat sold separately.	
Replacement Filters	N/A	AIR-FILTER-10PK	Replacement air filters in package of 10	
Energy Management	52C,P-10SI	EM-KIT	Allows unit to be turned on and off from a remote location (includes freeze guard protection)	
Locking Security Control Door	52C,P-13SI	SECURITY-DOOR	Key-locking security door to prevent access to heating and cooling controls	
Lateral Duct Kit	52C,P-14SI	LATERAL-DUCT	Ductwork to allow one unit to heat and cool two rooms (plenum plus extension duct and registers)	
Air Deflector	52C,P-9SI	DEFLECTOR-1PK	Lateral air deflector, with individually adjustable louvers, to enhance air circulation, 1 per pack	

*Extended metal wall sleeve also available in 26 in. and 20 in. deep.

†Custom colors are also available.

Carrier Packaged Terminal Air Conditioner Warranty

FULL ONE-YEAR WARRANTY — During the first year after purchase, CARRIER will, through its authorized independent servicing dealers or service stations*, and free of charge to the user or subsequent users, repair or replace any parts which are defective in material or workmanship. The replacement part can be a new or remanufactured part as provided at CARRIER'S sole option.

FULL EXTENDED FOUR-YEAR WARRANTY ON SEALED REFRIGERATION SYSTEM ONLY — During the second through fifth years after date of original purchase, CARRIER will, through its authorized servicing dealers and service stations*, and free of charge to the end user or subsequent users, repair or replace the compressor, condenser, evaporator or connecting tubing if defective in material or workmanship. This includes system refrigeration charge. The replacement part can be new or a remanufactured part as provided at CARRIER'S sole option.

LIMITED EXTENDED FOUR-YEAR WARRANTY ON NON-SEALED REFRIGERATION SYSTEM ONLY — During the second through fifth years after date of original purchase, Carrier will, through its authorized servicing dealers and service stations and free of charge to the end user or subsequent users, repair or replace any non-sealed system part (motor, solenoid, thermistor, thermostat, relays, switch, capacitor, overload, drain valve, bulb heater, fan, stator) if defective in material or workmanship. The replacement part can be new or a remanufactured part at CARRIER'S sole option. THIS LIMITED WARRANTY DOES NOT INCLUDE LABOR, user is responsible for labor, including cost of diagnosis of problem, removal and transportation of the air conditioner to and from the service center, and reinstallation charges necessary to accomplish repair.

LIMITATION OF WARRANTIES — ALL IMPLIED WARRANTIES (INCLUDING IMPLIED WARRANTIES OF MERCHANTABILITY) ARE HEREBY LIMITED IN DURATION TO THE PERIOD FOR WHICH EACH LIMITED WARRANTY IS GIVEN AND APPLIES. SOME STATES DO NOT ALLOW LIMITATIONS ON HOW LONG AN IMPLIED WARRANTY LASTS, SO THE ABOVE LIMITATION MAY NOT APPLY TO YOU. THE EXPRESSED WARRANTIES MADE IN THIS WARRANTY ARE EXCLUSIVE AND MAY NOT BE ALTERED, ENLARGED, OR CHANGED BY ANY DISTRIBUTOR, DEALER, OR OTHER PERSON WHATSOEVER.

ALL WORK UNDER THE TERMS OF THIS WARRANTY SHALL BE PERFORMED DURING NORMAL WORKING HOURS. ALL REPLACEMENT PARTS, WHETHER NEW OR REMANUFACTURED, ASSUME AS THEIR WARRANTY PERIOD ONLY THE REMAINING TIME PERIOD OF THIS WARRANTY.

CARRIER WILL NOT BE RESPONSIBLE FOR:

1. Damage due to failure to perform normal maintenance as outlined in the owner's manual.
2. Instruction on methods of control and use of air conditioning unit after initial installation.
3. Damage or repairs needed as a consequence of faulty installation or application. This is the responsibility of the installer.
4. Failure to start due to voltage conditions, blown fuses, open circuit breakers or any other damages due to the inadequacy or interruption of electrical services.
5. Damage or repairs needed as a consequence of any misapplication, abuse, unauthorized alteration, improper servicing or operation.
6. Damage as a result of floods, winds, fires, lightning, accidents, corrosive environment, or other conditions beyond the control of CARRIER.
7. EXCEPTION TO CORROSIVE ENVIRONMENT IN ABOVE PARAGRAPH — Packaged terminal units (52 Series) built with corrosion protection are exempt from the exclusion — "Corrosive Environment." The unit model number is identified on the nameplate with a CP suffix.
8. Reimbursement for replacement parts or repair services which are not supplied or designated by CARRIER and which are specifically covered under this warranty.
9. CARRIER products installed outside the continental U.S.A., Alaska, Hawaii and Canada.
10. Shipping damage or damage as a result of transporting the unit. This is the responsibility of the selling dealer or the authorized Room Air Conditioner service station.
11. ANY SPECIAL, INDIRECT OR CONSEQUENTIAL PROPERTY OR COMMERCIAL DAMAGE OF ANY NATURE WHATSOEVER. Some states do not allow the exclusion or limitation of incidental or consequential damages, so the above limitation or exclusion may not apply to you.

NOTE: Service and Maintenance items excluded in this warranty may be covered by a separate service agreement through the seller at time of purchase.

* Authorized independent dealers or service stations are registered with Carrier Air Conditioning thru its distributor organization.

This warranty gives you specific legal rights, and you may also have other rights which vary from state to state.

Form No. 530-122 (New 4/01)



Carrier Corporation

IF YOUR AIR CONDITIONER DOES NOT WORK, FOLLOW THESE STEPS IN ORDER:

1. CHECK THE THINGS YOU CAN DO YOURSELF. These include being sure the air conditioner is plugged in firmly in an appropriate receptacle, checking the fuse or circuit breaker and ensuring its re- placement or resetting, if necessary, and rereading the instruction book to ensure that all controls are set properly. By doing this you can save money. Many unnecessary service calls result in the serviceman doing what the owner can do for him or herself.
2. CONTACT YOUR DEALER OR THE CARRIER AUTHORIZED SERVICE CENTER HE RECOMMENDS. They have been set up to handle the great majority of all possible service problems. The quickest, surest, and best way to get your air conditioner back in service is to use this step before proceeding further.
3. CONTACT THE CARRIER DISTRIBUTOR SERVING YOUR AREA. Your dealer can give you his name or you can consult your yellow pages.
4. CONTACT CARRIER IF A SATISFACTORY SOLUTION IS NOT REACHED IN STEPS 2 AND 3.
Carrier Air Conditioning
Consumer Relations Department
Carrier Parkway, P.O. Box 4808
Syracuse, New York 13221
Telephone: 1-800-894-6449