

This Owner's Manual is provided and hosted by [Appliance Factory Parts](#).



Goodman CK36-1A Owner's Manual

[Shop genuine replacement parts for Goodman
CK36-1A](#)



[Find Your Goodman Air Conditioner Parts - Select From 15 Models](#)

----- Manual continues below -----

INSTALLATION & OPERATING INSTRUCTIONS

HAVE YOU DISCUSSED WITH YOUR
INSTALLING CONTRACTOR THE
OPTIONAL \$ 300.00 2ND THROUGH
5TH YEAR COMPRESSOR LABOR
ALLOWANCE PROGRAM?

For The United States and Canada only

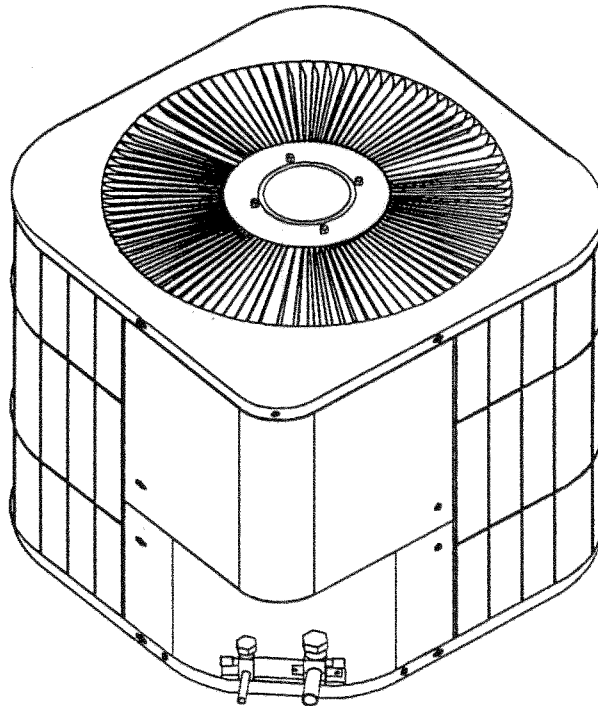

CK - SERIES CONDENSING UNIT

Goodman Manufacturing Co., L.P.
1501 Seamist, Houston, Texas 77008
(713) 861-2500

IMPORTANT MESSAGE TO OWNER:

These instructions should be carefully read and kept near product, for future reference. While these instructions are addressed primarily to the installer, useful maintenance information is included. Have your installing dealer acquaint you with the operating characteristics of the product and periodic maintenance requirements.

CODES AND REGULATIONS

This product is designed and manufactured to permit installation in accordance with National Codes. It is the installers responsibility to install the product in accordance with National Codes and/or prevailing local codes and regulations.

The manufacturer assumes no responsibility for equipment installed in violation of any code or regulations.

INSPECTION

This product has been inspected at the factory and released to the transportation agency without known damage. Inspect exterior of carton for evidence of rough handling in shipment. Unpack carefully, if damage is found, report immediately to the transportation agency.

REPLACEMENT PARTS

Order all replacement parts through your local distributor. When ordering parts, give complete model and serial number as shown on the unit rating plate.

INSTALLATION

The condensing unit is designed to be located outside the building with free unobstructed condenser air inlet and discharge. Additionally the unit must be situated to permit access for service and installation. Condenser air enters from three sides. Air discharges upward from the top of the unit. Refrigerant tube and electrical connections are made on the right side of the unit as you face the compressor compartment. The most common application will find the unit best located 6" to 10" from a back wall with the connection side facing the wall. This "close to the wall" application minimizes exposed tubing and wiring, minimizing the space for youngsters to run around the unit with subsequent damage to the tubes or wiring. (See fig. 1).

Close to the wall application assures free, unobstructed to the other two sides. In more confined application spaces, such as corners provide a minimum of 10" clearance on all air inlet sides. For service access to the compressor compartment and controls, allow 18" minimum.

We assume the top is completely unobstructed. If units are to be located under an overhang, there should be a minimum of 36" clearance and provision made to deflect the warm discharge air out from the overhang. See Table 3 for relative elevation limitations and maximum refrigerant line lengths.

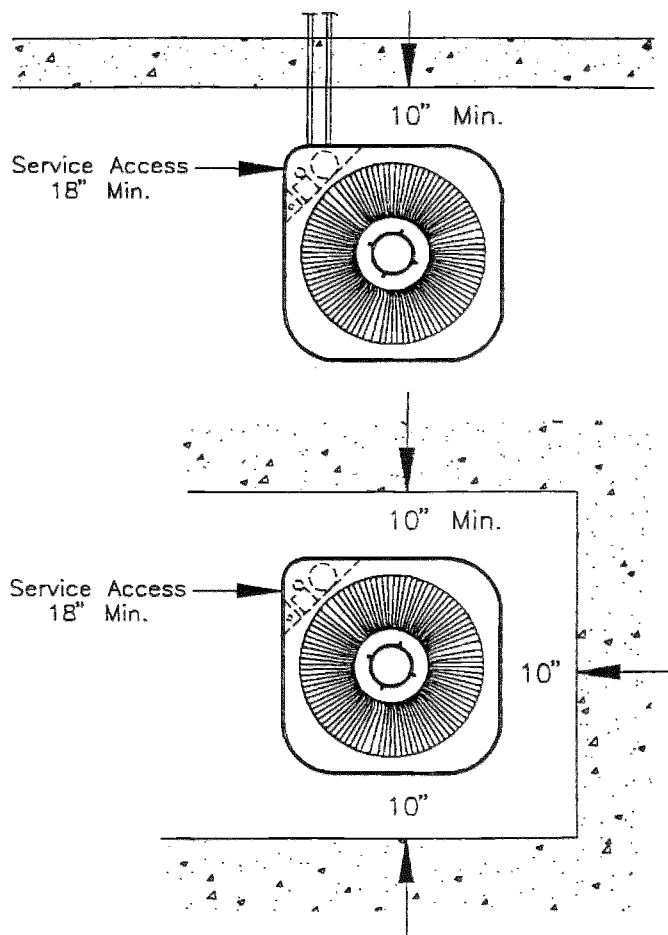

UNIT LOCATION

Figure 1

The condensing unit must be mounted on a solid, level foundation, i.e. preformed concrete slab or other suitable base. For rooftop application, make sure the building construction can support the weight and that proper consideration is given the weather-tight integrity of the roof. The condensing unit contains moving components and can vibrate, therefore, sound is also a consideration in rooftop application. Since these units discharge warm condenser air from the top with cooler air being drawn in three sides, plantings can be made in relatively close proximity to the unit. Owners should be advised to avoid lawn mower discharge toward the unit depositing debris on the fin coil surface reducing product efficiency.

ELECTRICAL SERVICE

Electrical installation will consist of power supply wiring to

the condensing unit as well as control wiring between thermostat, indoor unit and the condensing unit. All wiring must be in accordance with National Electrical Code and/or local codes that may apply. (See unit wiring diagram furnished with this instruction).

The condensing unit rating plate and the table inside the front cover of this instruction lists pertinent electrical data necessary for the selection of proper size electrical service and over-current protection. The owner should be made familiar with the location of the over-current protection, the proper size for this application and the proper procedure for disconnecting power service to the unit.

The condensing unit control wiring requires a 24 Volt minimum 25 VA service from the indoor transformer as shown on the wiring diagram.

REFRIGERANT TUBING

Use only refrigerant grade (dehydrated and sealed) copper tubing of the size indicated in Table 1 to interconnect the condensing unit with the indoor evaporator. Take extreme care to keep the refrigerant tubing clean and dry prior to and during installation.

Do not remove plugs from ends of tubing until connection is ready to be made.

Suction line insulation is necessary to prevent condensation from forming on and dripping from suction line. Generally 3/8" wall thickness of *Arm flex* or equivalent is satisfactory. In severe application (hot, high humidity areas) greater thickness may be required. Apply suction line insulation by sliding it on the sealed tubing before cutting and making connections.

EVAPORATOR COILS

CAUTION: USE EXTREME CARE IN REMOVING THE CAPS FROM THE SUCTION AND LIQUID LINE FITTINGS, AS THERE IS PRESSURE PRESENT. SWEAT CAPS SHOULD BE PUNCTURED PRIOR TO APPLICATION OF HEAT.

SYSTEM START UP

Condensing units are supplied with R-22 charge sufficient for typical matching evaporator and approximately 25' of interconnecting tubing. Condensing unit liquid and suction valves are closed to contain the charge within the unit. The recommended procedure for processing and charge adjustment is as follows:

1. Connect vacuum pump to both base valve service ports.
2. Evacuate tubing and evaporator thru liquid and suction base valve ports, to 500 microns or less for a minimum of 30 minutes. Close valve to pump and wait 15 minutes. Vacuum should not rise above 800 microns. If unable to obtain 500 microns, or vacuum rises above 800 microns over 15 minute period, discontinue evacuation, pressurize and check for leaks. Repair any leaks found and repeat step 2.
3. Close valve to vacuum pump and stop pump. Break vacuum by opening liquid and suction base valves. Fully open base valves and remove pump lines. Connect service gages being sure to purge lines.
4. Set thermostat system switch to "cool" and temperature to highest setting. Close all disconnects.
5. Set thermostat to call for cooling. Check for operation of indoor and outdoor fans. Allow for at least 10 minutes.
6. Check charge and adjust if necessary. (Refer to Appropriate "Checking Charge" section).

Table 1

COND UNIT (TONS)	REFRIGERANT LINE LENGTH (ft)											
	0-24		25-49		50-74		75-99		100-124		125-149	
	Line Diameter (in. OD)											
	Suct	Liq	Suct	Liq	Suct	Liq	Suct	Liq	Suct	Liq	Suct	Liq
1-1/2	5/8	1/4	3/4	3/8	3/4	3/8	3/4	3/8	3/4	3/8	7/8	1/2
2	3/4	3/8	3/4	3/8	3/4	3/8	7/8	1/2	7/8	1/2	7/8	1/2
2-1/2	3/4	3/8	3/4*	3/8	7/8	1/2	7/8	1/2	7/8	1/2	1-1/8	1/2
3	3/4	3/8	3/4**	3/8	7/8	1/2	1-1/8	1/2	1-1/8	1/2	1-1/8	1/2
3-1/2	3/4	3/8	7/8**	3/8	1-1/8	1/2	1-1/8	1/2	1-1/8	1/2	1-1/8	5/8
4	7/8	3/8	1-1/8	3/8	1-1/8	1/2	1-1/8	1/2	1-1/8	5/8	1-3/8	5/8
5	7/8	3/8	1-1/8	3/8	1-1/8	1/2	1-1/8	1/2	1-3/8	5/8	1-3/8	5/8

* 7/8" required for full ratings

** 1-1/8" required for full ratings

The following are instructions on the field connection to the valve and the valve opening procedure.

- (1) Tubing should be cut square. Make sure it is round and free of burrs at the connecting ends. Clean the tubing to prevent contamination from entering the system.
- (2) Wrap a wet rag around the copper valve stub before brazing.
- (3) Braze or silver solder the joint.
- (4) After brazing quench with a wet rag to cool the joint. Evacuate and charge the connecting lines as outlined in the Installation and Operating instructions.
- (5) Remove valve top cap. Keep the cap in a clean area so dirt does not get in the cap. This is important to be sure that when the cap is replaced after opening the valve it will properly seal.
- (6) Using a standard L shaped allen wrench break open the valve body. To opening the valve body after it is broken open use of a racket wrench with a short allen stub can be used. Please note that you will see oil on the valve stem body when the cap is removed. This oil is put in the valve by the manufacturer and is normal.
- (7) Replaced the valve cap finger tight and tighten with a wrench an additional 1/6 of a turn to insure a seal.

NOTE FOR QUICK CONNECT COILS

Installation of precharged system

Installation procedure will differ when condensing units are provided for use with precharged refrigerant coils and lines. Condensing units are provided with #6 and #11 male quick connects instead of liquid and suction valves attached to cabinet to contain the R22 charge that is sufficient for matching evaporator coils and 25' of interconnecting lines.

Coils are provided with #6 and #11 male quick connects. Line sets are required with #6 and #11 female quick connects on both ends. Access ports are required in the fittings of both liquid and suction lines at condenser end. Both coil and line sets included R22 holding charge only.

1. Connect lines to evaporator coil before connecting to the condensing unit locating access ports adjacent to condensing unit.
 - a. Form tubing so it properly aligns with coil connections.
 - b. Remove plugs and caps from connections.
 - c. Check to be sure mating surfaces are clean.
 - d. Lubricate rubber seal with clean refrigerant oil and thread couplings together by hand to be sure they are not cross threaded.
 - e. Tighten connections using backup wrench on stationary fitting until coupling bottoms; then tighten 1/6 turn to complete knife edge seal.
2. Connect lines to condensing unit in the same manner as to evaporator coil. Observe same precautions.
3. After making all connections and opening valves, check all piping for leaks.

Precharged lines

Caution

Do not remove protective caps until installation has been completed and final connections are to be made. USE EXTREME CARE IN REMOVING CAPS FROM SUCTION AND LIQUID LINE FITTINGS AS THERE IS PRESSURE PRESENT.

**CHECKING CHARGE-
CAPILLARY TUBE / FIXED ORIFICE SYSTEM**

1. Fully open both base valves.
2. Connect service gage manifold to base-valve service ports being sure to purge lines. Run system at least 10 minutes to allow pressure to stabilize.
3. Temporarily install thermometer on suction (large) line near condensing unit. Be sure of good contact between thermometer and line. Wrap thermometer with insulating material to assure accurate reading.
4. Refer to Table 2 for proper system superheat. Add charge to lower superheat. Bleed charge to raise superheat.
5. After adjusting charge for proper superheat, compare suction and liquid pressures to those shown in Table 3. If pressures are not within range, system trouble shooting is needed.
6. Remove gage lines carefully. Escaping liquid refrigerant can cause burns.

Table 3

Operating Pressure

Outdoor Temp. °F	Indoor Temp. °F		Liquid Pressure PSIG	Suction Pressure PSIG
	DB	WB		
115	75	63	301-332	73-83
		67	306-335	77-78
		71	311-342	82-92
105	75	63	268-299	72-82
		67	273-304	77-87
		71	278--309	80-90
95	75	63	233-264	67-77
		67	238-269	72-82
		71	243-274	77-87
85	75	63	198-229	62-72
		67	203-234	67-77
		71	208-239	71-81
75	75	63	172-203	57-67
		67	175-206	61-71
		71	180-211	66-76
65	75	63	144-175	52-62
		67	149-180	56-66
		71	155-186	60-70

SUPERHEAT CAN BE DETERMINED AS FOLLOWS

- a. Read suction pressure. Using Table 4 determine saturated suction temperature.
- b. Read suction line temperature.

SUPERHEAT = SUCTION LINE TEMP. - SAT. SUCT. TEMP.

Table 2

System Superheat

Ambient Condenser Inlet Temperature (°F Drybulb)	Return Air Temperature (°F Drybulb)				
	65	70	75	80	85
	100				5
95			5	5	5
90			7	12	18
85		5	10	17	20
80		5	12	21	26
75	5	10	17	25	29
70	5	14	20	28	32
65	13	19	26	32	35
60	17	25	30	33	37

Table 5

Saturated Suction Temperature (R-22)

Suction Pressure (PSIG)	Saturated Suction Temperature (°F)
50	26
53	28
55	30
58	32
61	34
63	36
66	38
69	40
72	42
75	44
78	46
81	48

EXPANSION VALVE SYSTEM

1. Fully open both base valves.
2. Connect service gage manifold to base-valve service parts being sure to purge lines. Run system at least 10 minutes to allow pressure to stabilize.
3. Temporarily install thermometer to liquid (small) line near condensing unit. Be sure of good contact between thermometer and line. Wrap thermometer with insulating material to insure accurate reading.
4. Adjust charge to obtain a temperature 12-15°F below the saturated liquid temperature determined from Table 5.

Example

**Liquid Pressure 260 PSIG
Saturated Temp. (Table 10) - 120°F
Adjust Charge to Liquid Line Temperature - 105°F**

Table 5

Liquid Pressure PSIG	Saturated Temperature °F
200	102
210	105
220	108
230	111
240	114
250	117
260	120
270	123
280	126
290	128
300	131

SPECIAL NOTE-

Systems With More Than 25 ft of Interconnecting Tubing

See Table 6 for line charge allowance per foot of tubing.

Table 6

Line Charge Allowance (R-22) oz./ft

Line O.D. (in.)	Liquid	Suction
1/4	0.22	
3/8	0.58	
1/2	1.14	
5/8	1.86	0.04
3/4		0.06
7/8		0.08
1 1/8		0.15
1 3/8		0.22

See Table 7 for charge allowance in the following filter driers.

Table 7

Filter Drier Charge Allowance (R22)

Liquid Line O.D. (in)	P-H		Sporlan		Alco	
	No.	Oz s	No.	Ozs	No.	Oz s
1/4	052	3.3	C-052	4.7	ADK-052	3.7
	082	5.4	C-082	7.8	ADK-082	4.7
3/8	053	3.3	C-053	4.7	ADK-053	3.7
	083	5.4	C-083	7.8	ADK-083	4.7
	163	5.9	C-163	10.8	ADK-163	8.6
1/2	084	5.4	C-084	7.8	ADK-084	4.7
	164	5.9	C-164	10.8	ADK-164	8.6
5/8			C-165	10.8		
			C-305	17.3		

Systems with over 50 ft. separation between condensing unit and evaporator may require oil charge adjustment. See Table 8

Table 8

UNIT MODEL	ADDITIONAL OIL REQUIRED (oz.) PER 10 FT OF LINE*
1 1/2 Ton	0.25
2-5 Ton	0.5

* Use Either Texaco WF-32 (formerly cappella B) or Suniso 3G-S oil.

Note:

When installing equipment with condenser and evaporator, more than 25' above or below, note special conditions that should be considered in Table 9.

Table 9

Refrig. Control	Max. Cond Unit Ht. (ft.)	
	Above Evap.	Below Evap.
TX Valve	50	25
Cap. Tube/Orifice	100	25