

This Owner's Manual is provided and hosted by [Appliance Factory Parts](#).



Kenmore 41728 Owner's Manual

[Shop genuine replacement parts for Kenmore 41728](#)



[Find Your Kenmore Washer Parts - Select From 132 Models](#)

----- Manual continues below -----



<http://www.managemyhome.com>

WASHING MACHINE SERVICE MANUAL

▲ CAUTION

READ THIS MANUAL CAREFULLY TO DIAGNOSE
PROBLEMS CORRECTLY BEFORE SERVICING THE UNIT.

MODEL : 796.4172#00#

CONTENTS

| | |
|---|----|
| 1. SPECIFICATIONS | 3 |
| 2. FEATURES & TECHNICAL EXPLANATION | 4 |
| 3. PARTS IDENTIFICATION | 7 |
| 4. INSTALLATION AND TEST | 8 |
| 5. OPERATION | 11 |
| 5-1. CONTROL PANEL FEATURES | 11 |
| 5-2. CYCLE GUIDE | 13 |
| 5-3. CYCLE OPTIONS | 15 |
| 5-4. SPECIAL FUNCTION | 16 |
| 5-5. EXPLANATION OF EACH PROCESS | 17 |
| 6. PROGRAM CHART | 19 |
| 7. TEST MODE | 21 |
| 7-1. SAFETY CAUTION | 21 |
| 7-2. LOAD TEST MODE | 21 |
| 7-3. HOW TO CHECK THE WATER LEVEL FREQUENCY | 21 |
| 8. TROUBLESHOOTING | 22 |
| 8-1. SAFETY CAUTION | 22 |
| 8-2. ERROR MODE SUMMARY | 22 |
| 8-3. TROUBLESHOOTING SUMMARY | 24 |
| 8-4. TROUBLESHOOTING WITH ERROR | 26 |
| 8-5. TROUBLESHOOTING ELSE | 31 |
| 9. COMPONENT TESTING INFORMATION | 36 |
| 9-1. FILTER ASSEMBLY (LINE FILTER) | 36 |
| 9-2. DOOR LOCK SWITCH ASSEMBLY | 37 |
| 9-3. STATOR ASSEMBLY | 39 |
| 9-4. PUMP MOTOR ASSEMBLY | 42 |
| 9-5. INLET VALVE ASSEMBLY | 43 |
| 9-6. HEATER ASSEMBLY | 44 |
| 9-7. THERMISTOR ASSEMBLY | 45 |
| 10. DISASSEMBLY INSTRUCTIONS | 48 |
| 11. EXPLODED VIEW | 56 |
| 11-1. CABINET AND CONTROL PANEL ASSEMBLY | 56 |
| 11-2. DRUM AND TUB ASSEMBLY | 57 |
| 11-3. DISPENSER ASSEMBLY | 58 |

1. SPECIFICATIONS

| | | |
|-------------------------------|-------------|--|
| ITEM | | 796.4172#00# |
| COLOR | | White, Patina Beige |
| POWER SUPPLY | | AC 120 V, 60 Hz |
| PRODUCT WEIGHT | | 215.8 lbs (97.9kg) |
| ELECTRIC POWER CONSUMPTION | WASHING | 280 W |
| | DRAIN MOTOR | 50 W |
| | WASH HEATER | 1000W |
| REVOLUTION SPEED | WASH | 46 rpm |
| | SPIN | 0-1400 rpm |
| CYCLE | | 14 |
| WASH/RINSE TEMPERATURES | | 5 |
| SPIN SPEEDS | | 5 |
| OPTIONS | | DELAY START, EXTRA RINSE, STAIN TREAT, STAY FRESH, SAVE ENERGYⓈ, PRE-WASH, SMART SENSE, CONTROL LOCK, Clean WasherⓈ, MY CYCLE, DRUM LIGHT, AUTO SOAK |
| OPERATIONAL WATER PRESSURE | | 14.5-116 psi (100-800 kPa) |
| CONTROL TYPE | | Electronic |
| WASH CAPACITY [cu.ft] | | 4.16 (4.8 IEC) |
| DIMENSIONS | | 26 ^{1/4} " (W) X 30 ^{1/3} " (D) X 38 ^{15/16} " (H) ,54 ^{3/8} " (D, door open) |
| DELAY START | | up to 19 hours |
| DOOR SWITCH TYPE | | PTC + Solenoid |
| WATER LEVEL | | 10 steps (by sensor) |
| LAUNDRY LOAD SENSING | | Incorporated |
| ERROR DIAGNOSIS | | Incorporated |
| AUTO POWER OFF | | Incorporated |
| CONTROL LOCK | | Incorporated |

2. FEATURES & TECHNICAL EXPLANATION

2-1. FEATURES

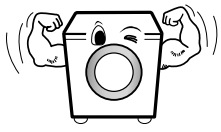

■ Ultra Capacity

The Larger drum enables not just higher head drop and stronger centrifugal force, but also less tangling and wrinkling of the laundry. Heavier loads, such as king size comforters, blankets, and curtains, can be washed.



■ Direct Drive System

The advanced Brushless DC motor directly drives the drum without belt and pulley.

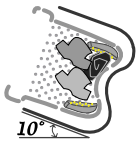

■ Tilted Drum and Extra Large Door Opening

Tilted drum and extra large opening make it possible to load and unload clothing more easily.

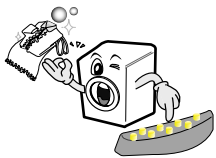

■ RollerJets

Washing ball enhances the wash performance and reduces damage to the clothing. The jets spray and help tumble clothes to enhance washing performance while maintaining fabric care.

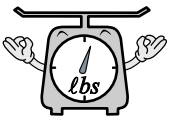

■ Automatic Wash Load Detection

Automatically detects the load and optimizes the washing time.



■ Built-in Heater

Internal heater helps to maintain water temperature at its optimum level for selected cycles.



■ Control Lock

The Control lock prevents children from pressing any button to change the settings during operation.

2-2. NEURO FUZZY WASHING TIME OPTIMIZATION

To get the best washing performance, optimal time is determined by the water temperature, the selected washing temperature, and the size of the load.

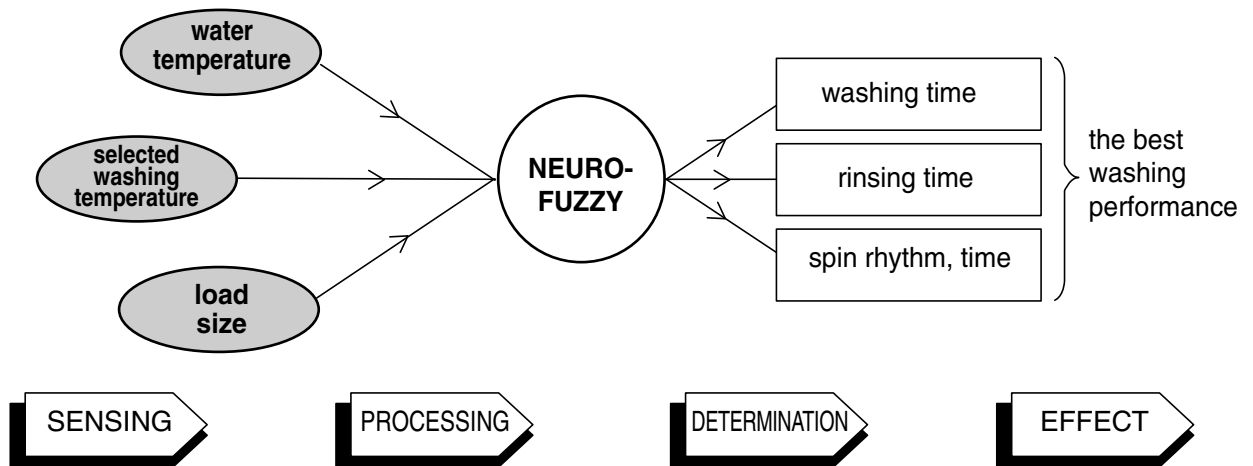

2-3. WATER LEVEL CONTROL

- This model incorporates a pressure sensor which can sense the water level in the tub.
- The water supply is stopped when the water level reaches the preset level, the washing program then proceeds.
- Spinning does not proceed until the water in the tub drains to a certain level.

2-4. DOOR CONTROL

- The door can be opened by pulling the door handle whenever washer is not in operation.
- When the cycle is completed, the DOOR LOCKED light will turn off.
- If a power failure has occurred while in operation, the door will unlock after 5 minutes.
- Clicking sounds can be heard when the door is locked/unlocked.

2-5. THE DOOR CAN NOT BE OPENED

- While program is operating.
- When a power failed and power plug is taken out in operation
- While Door Lock lights turn on.
- While the motor is in the process of inertial rotating, through the operation is paused.

2-6. CONTROL LOCK

- Use this option to prevent unwanted use of the washer. Press and hold CONTROL LOCK button for 5 seconds to lock/unlock control.
- When CONTROL LOCK is set, CONTROL LOCK lights and all buttons are disabled.
You can lock the controls of the washer while washing.

2-7. WATER CIRCULATION

- When washing and rinsing function of shower at the upper part of Gasket.
- When washing, it continuously operates for 3 minutes and intermittently.
- When rinsing, it continuously operates after completion of water supply.

2-8. STEAM

- For tough stained clothes, sick room linens, or baby clothes.
- Steam Wash is available with Sanitary, Bulk/Large, Perm. Press, Cotton/Normal, and Baby Wear cycles.
- This option features upgraded washing performance with low energy and water consumption.
- Do not load delicates such as wool, silk, and easily discolored clothes.

2-9. DRUM LIGHT

- The drum light comes on when the power button is pressed. It goes off when the door is closed and the washer starts operation.
- The drum light remains off when the door is locked.
- The drum light can be turned on while the washer is in operation by pressing the DELAY WASH button for 3 seconds. The light will turn off automatically 4 minutes later.
- The drum light comes on when the washing cycle is finished and goes off 4 minutes later.

3. PARTS IDENTIFICATION

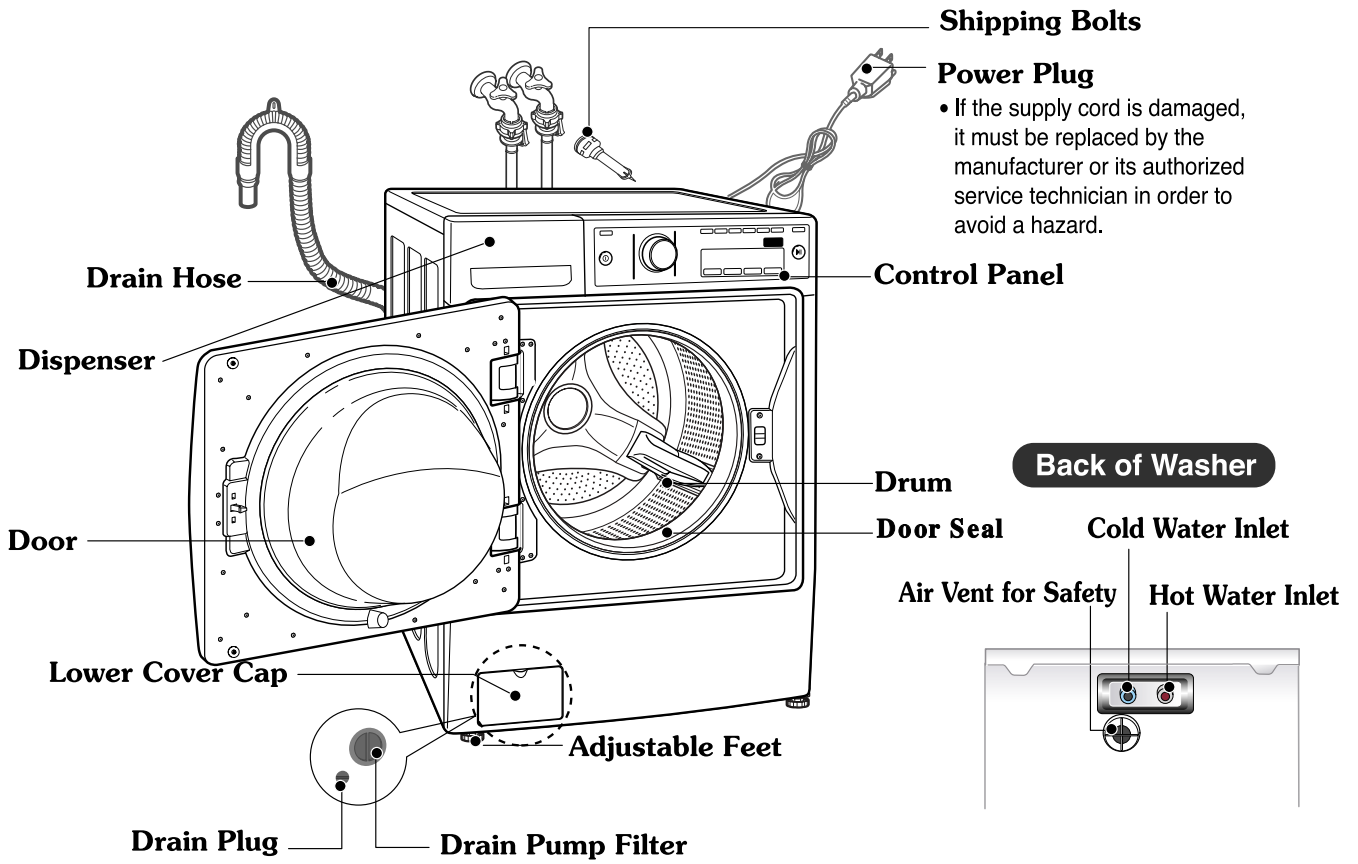

■ ACCESSORIES

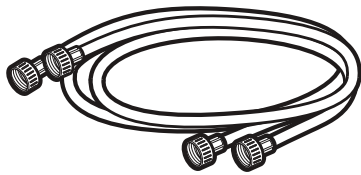

Hot and Cold Water Hoses

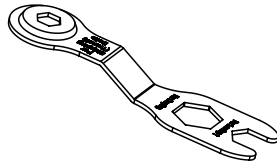

Wrench

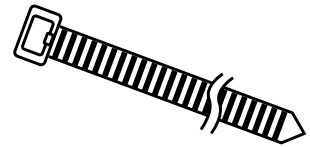

Tie strap (Option)
to secure drain hose to standpipe, inlet hose, or laundry tub

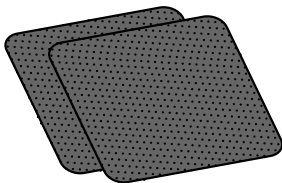

Non-skid pads

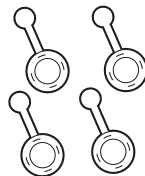

Caps(4)
(for covering shipping bolt holes)

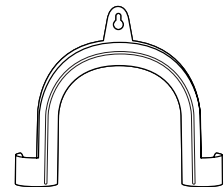

Elbow Bracket
(for securing drain hose)

4. INSTALLATION & TEST

- 1 Before servicing, ask the customer what the trouble is.
- 2 When installing or repairing the washer, put on long sleeve gloves and safety glasses.
- 3 Check the setup (power supply is 120V, remove the transit bolts, level the washer...)
- 4 Check with the troubleshooting guide.
- 5 Plan your service method by referring to the disassembly instructions.
- 6 Service the unit.
- 7 After servicing, operate the appliance to see whether it functions correctly.

■ STANDARD INSTALLATION

The appliance should be installed as follows:

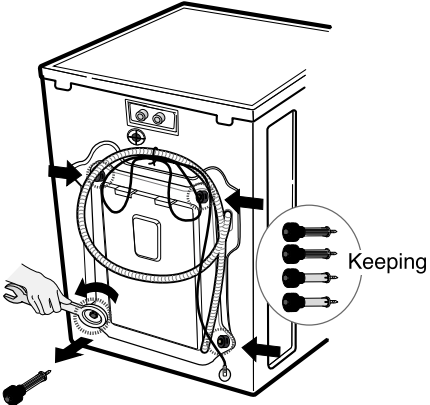
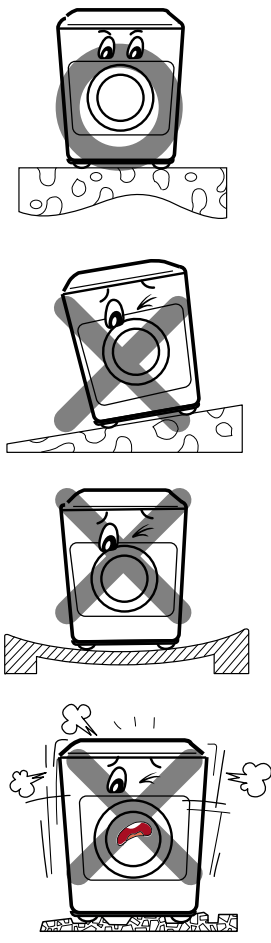
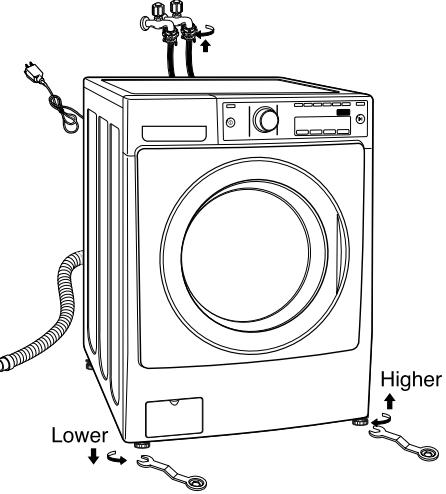
| REMOVE THE SHIPPING BOLTS | INSTALL THE APPLIANCE ON A FLAT AND FIRM SURFACE | ADJUST THE LEVELING |
|--|--|--|
| <ul style="list-style-type: none"> • Remove the 4 shipping bolts with the supplied wrench. ※ Do first lower side to remove easily. • Keep the shipping bolts and spanner for future use. • Insert the 4 caps (provided) into the hole.  |  | <ul style="list-style-type: none"> • Turn the leveling feet to adjust the appliance.  <ul style="list-style-type: none"> • Turn clockwise to raise; counterclockwise to lower. |

■ HOW TO CONNECT THE INLET HOSE

- Check the rubber seals on both sides of the hose.
- Connect the water hoses to the faucets.
- Turn on the water tap to remove foreign substance such as dirt, sand, or sawdust in the water line, and then check the water temperature.
- Connect the hoses to the water inlets.

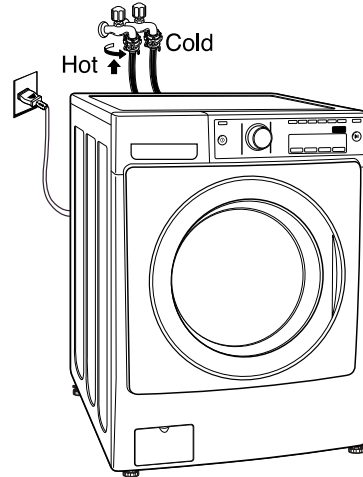

■ CONNECT THE DRAIN HOSE

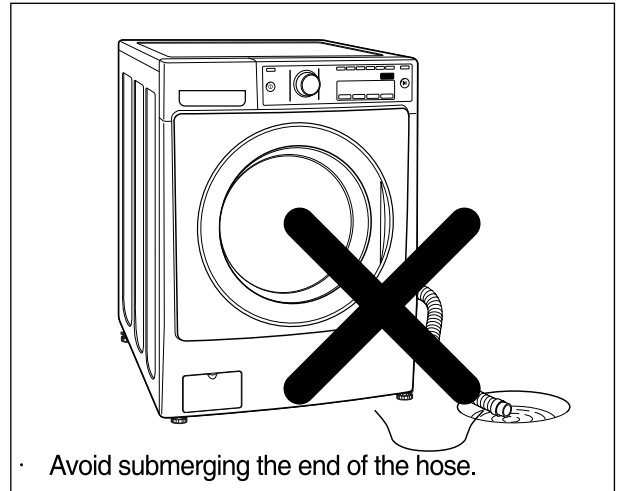
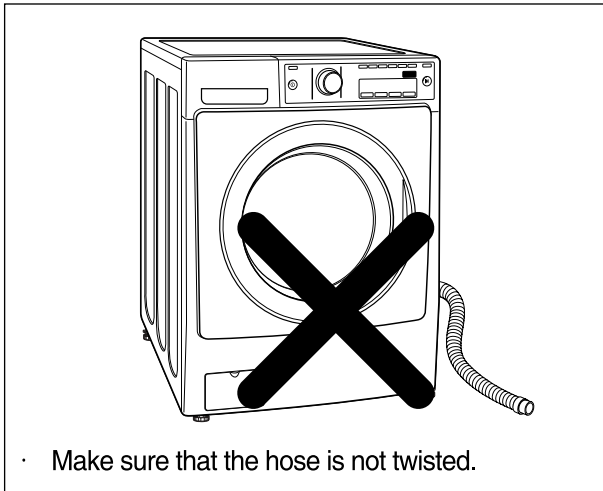

※ The end of the drain hose should be placed less than 96" from the floor.

■ CONNECT POWER PLUG

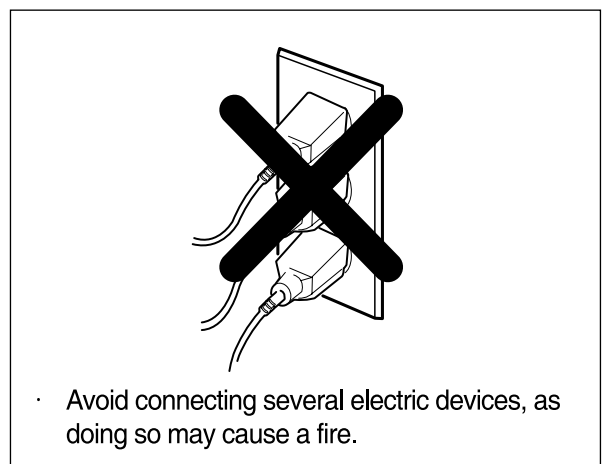
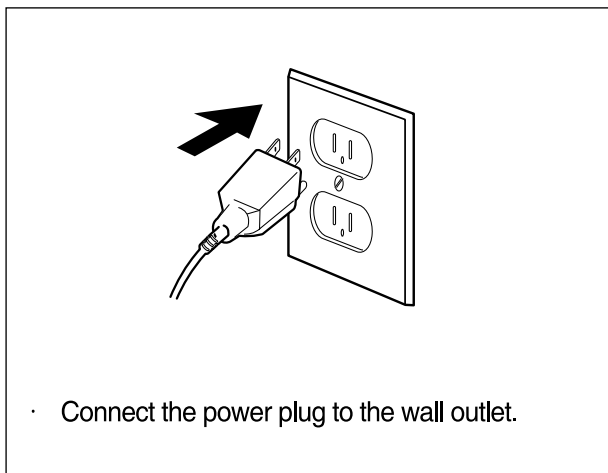

7 TEST OPERATION

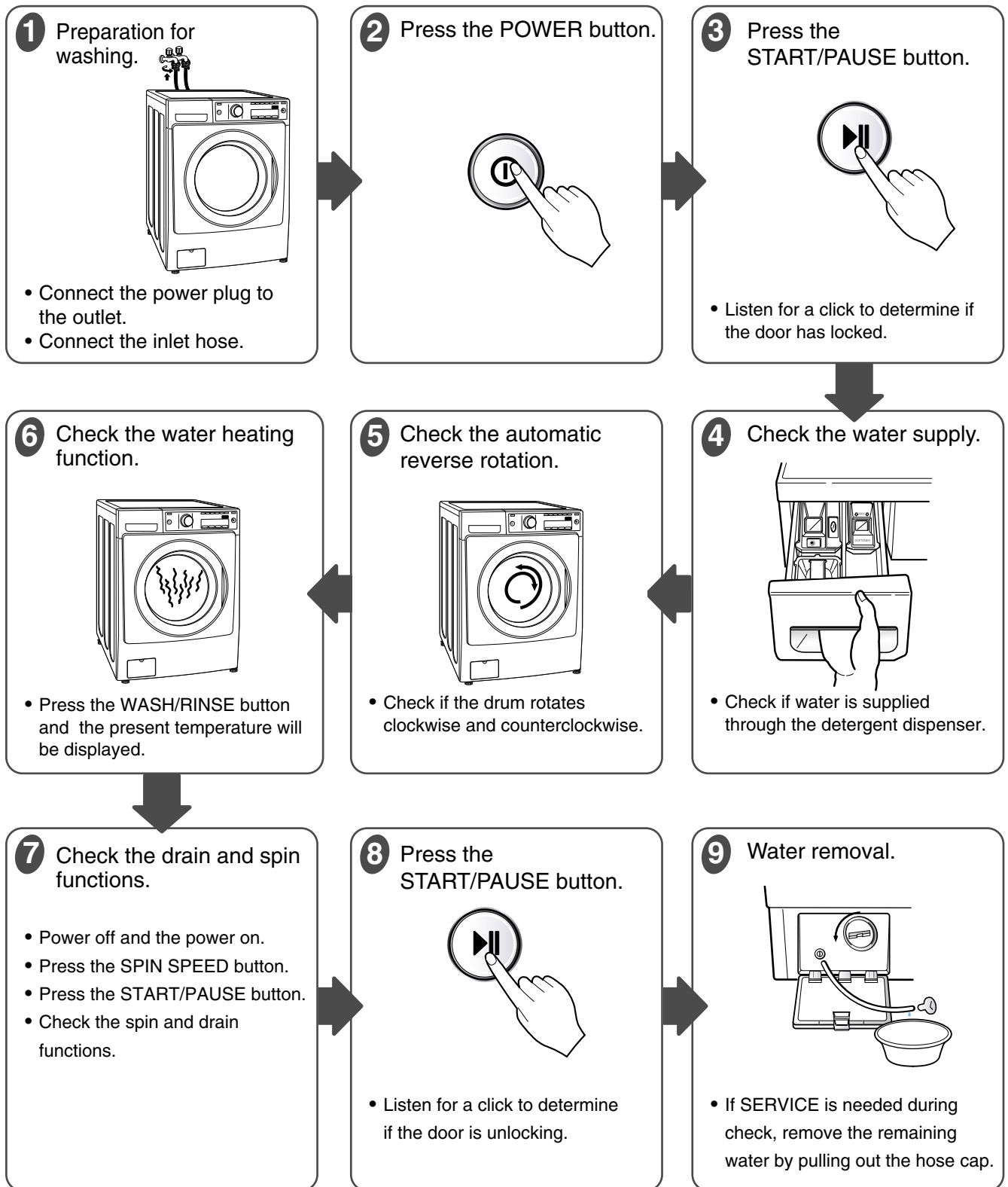

5. OPERATION

5-1. CONTROL PANEL FEATURES

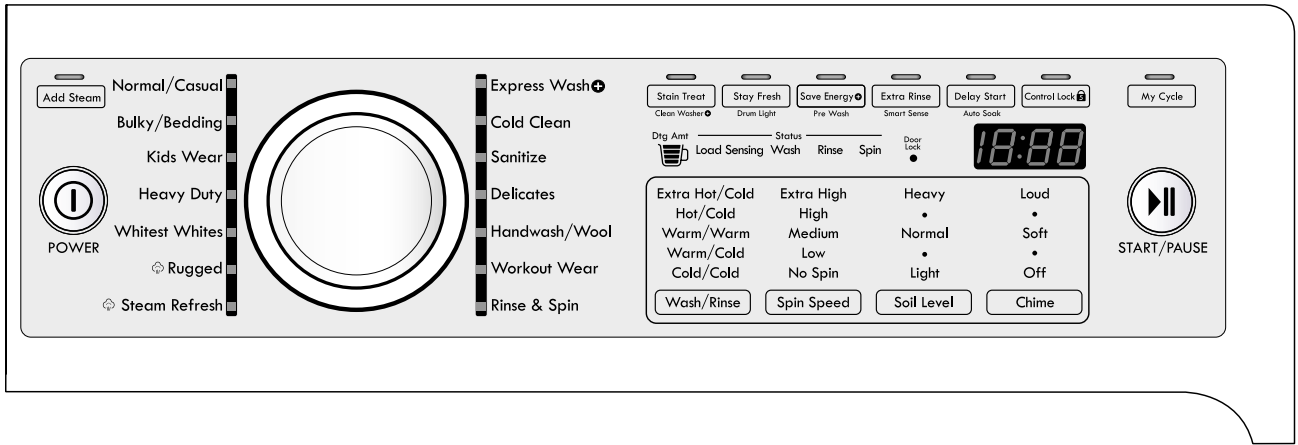

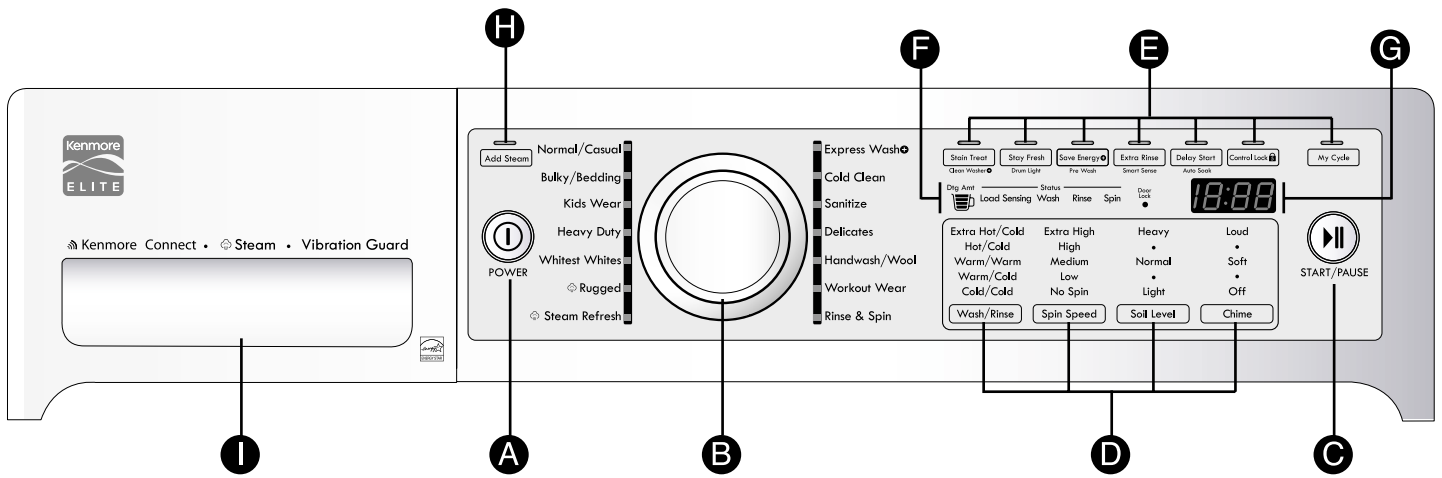

A POWER (ON/OFF) BUTTON

Press to turn the washer ON. Press again to turn the washer OFF.

NOTE: Pressing the POWER button during a cycle will cancel that cycle and any load settings will be lost. The door will unlock after a brief pause, unless the water level or temperature is too high.

B CYCLE SELECTOR KNOB

Turn this knob to select the desired cycle. Once the desired cycle has been selected, the standard presets will appear in the display. These settings can be adjusted using the cycle setting buttons anytime before starting the cycle (13 and 14).

C START/PAUSE BUTTON

Press this button to start the selected cycle. If the washer is running, use this button to pause the cycle without losing the current settings.

NOTE: If you do not press the START/PAUSE button within four minutes of selecting a cycle, the washer automatically turns OFF.

D CYCLE MODIFIER BUTTONS

Use these buttons to adjust the settings for the selected cycle. The settings light up above the buttons to show the current selection.

E SPECIAL CYCLE AND OPTION BUTTONS

These buttons are used to activate special cycle or options.

F DETERGENT AMOUNT INDICATOR (Dtg. Amt)

The detergent amount indicator bars light up to indicate the size of dry load sensed by washer control. Follow the detergent manufacturer's recommendations for amount of detergent to use based on load size. Indicator will not be accurate if any wet clothes are placed in the washer.

NOTE: The detergent amount indicator icon does not represent an actual detergent measuring cup or cap. This feature is not available on all cycles.

G TIME AND STATUS DISPLAY

The display shows the cycle status, door lock status and estimated time remaining.

H ADD STEAM BUTTON

Press the ADD STEAM button to add steam to the selected cycle for added cleaning power.

NOTE: The steam option is not available on all cycles.

I DISPENSER DRAWER

This drawer contains the compartments for detergent and additives.

NOTE: To protect your clothing, not all settings are available on all cycle selections (refer to pages 13 and 14).

5-2. CYCLE GUIDE

The cycle guide below shows the default settings, available options and recommended fabric types for each cycle. Allowable modifier adjustments are shown below the default setting for each cycle. ● = Available option

■ 796.4172#00#

■ = Default setting

| Cycle | Fabric or Load Type | Display Time (Min.) | Load Sensing | Wash Motion | Wash/Rinse Temperature | Spin Speed | Soil Level | Add Steam | Extra Rinse | Stain Treat | Auto Soak | Save Energy ⁺ | Pre-Wash | Smart Sensor |
|----------------|--|---------------------|--------------|-------------|---|--|-----------------|-----------|-------------|-------------|-----------|--------------------------|----------|--------------|
| Normal/Casual | Cotton, linen, towels, shirts, sheets, jeans, mixed loads | 45-60 | Yes | Yes | Warm/Cold | High | Normal | ● | ● | ● | ● | ● | ● | ● |
| | | | | | Hot/Cold Cold/Cold | Extra High No Spin Low Medium | Heavy Light | | | | | | | |
| Bulky/Bedding | Large items such as blankets and comforters | 65 | No | Yes | Warm/Cold | Low | Normal | ● | ● | ● | ● | ● | ● | ● |
| | | | | | Warm/ Warm Hot/Cold Cold/Cold | Medium No Spin | Heavy Light | | | | | | | |
| Kids Wear | Specifically designed to clean and thoroughly rinse kids wear | 86-103 | Yes | Yes | Hot/Cold | High | Heavy | ● | ● | ● | ● | ● | ● | ● |
| | | | | | Cold/Cold Warm/Cold Warm/ Warm | Extra High No Spin Low Medium | Light Normal | | | | | | | |
| Heavy Duty | Heavily soiled cotton fabrics | 89-103 | Yes | Yes | Warm/Cold | Extra High | Heavy | ● | ● | ● | ● | ● | ● | ● |
| | | | | | Warm/ Warm Hot/Cold Cold/Cold | No Spin Low Medium High | Light Normal | | | | | | | |
| Whitest Whites | Heavily to normally soiled white cottons | 66-83 | Yes | Yes | Hot/Cold | High | Normal | ● | ● | ● | ● | ● | ● | ● |
| | | | | | Cold/Cold Warm/Cold Warm/ Warm | Extra High No Spin Low Medium | Heavy Light | | | | | | | |
| Rugged | Heavily soiled hard and thick items such as jeans and construction work wear | 90-105 | Yes | Yes | | High | | ● | ● | | | | | |
| Steam Refresh | Dress shirts, blouses (load up to five garments) | 20 | No | Yes | | | | ● | | | | | | |

NOTE: To protect your garments, not every wash/rinse temperature, spin speed, soil level, or option is available with every cycle. A chime will sound and the LED will not light if the selection is not allowed.

- The washer automatically adjusts the wash time for the amount of laundry, water pressure, water heating time and other operating conditions.
- These cycles use various wash motions to enhance cleaning and/or fabric care performance. The wash motions may sound different at different stages of the wash cycle. This is normal.
- Recommended test load size of sanitize course is 10 lbs.

5-2. CYCLE GUIDE

CYCLE GUIDE

The cycle guide below shows the default settings, available options and recommended fabric types for each cycle. Allowable modifier adjustments are shown below the default setting for each cycle.

● = Available Option
 ■ = Default Setting

| Cycle | Fabric or Load Type | Display Time (Min.) | Load Sensing | Wash Motion | Wash/Rinse Temperature | Spin Speed | Soil Level | Add Steam | Extra Rinse | Stain Treat | Auto Soak | Save Energy | Pre-Wash | Smart Sensor |
|----------------|--|---------------------|--------------|-------------|-------------------------------------|--|-----------------|-----------|-------------|-------------|-----------|-------------|----------|--------------|
| Express Wash | Lightly soiled clothing and small loads | 15 | No | Yes | Hot/Cold | Extra High | Light | | | | | | | |
| | | | | | Cold/Cold Warm/Cold Warm/Warm | No Spin Low Medium High | Normal Heavy | | ● | | | | | |
| Cold Clean | Small loads of cotton, linen, towels, shirts, sheets, jeans, mixed loads | 50-68 | Yes | Yes | Cold/Cold | High | Normal | | | | | | | |
| | | | | | | Extra High No Spin Low Medium | Light | | ● | | ● | | ● | |
| Sanitize | Heavily soiled items, such as work clothes, diapers, etc. | 98-113 | Yes | Yes | Extra Hot/Cold | High | Normal | | | | | | | |
| | | | | | | Extra High No Spin Low Medium | Heavy Light | ● | ● | ● | ● | | ● | ● |
| Delicates | Dress shirts/blouses, nylons, sheer or lacy garments | 43 | No | Yes | Cold/Cold | Medium | Normal | | | | | | | |
| | | | | | Warm/Cold Warm/Warm | No Spin Low | Heavy Light | | ● | | ● | | ● | |
| Handwash/Wool | Items labeled hand washable | 57 | No | Yes | Warm/Cold | Low | Normal | | | | | | | |
| | | | | | Warm/Warm Cold/Cold | No Spin | Light | | | | | | | |
| Workout Wear | Permanent press, synthetic items | 63 | No | Yes | Warm/Cold | Medium | Normal | | | | | | | |
| | | | | | Warm/Warm Cold/Cold | No Spin Low | Heavy Light | | ● | | ● | | | |
| Rinse and Spin | Loads that only need to be rinsed | 20 | No | No | Cold/Cold | High | | | | | | | | |
| | | | | | | Extra High No Spin Low Medium | | | ● | | | | | |

NOTE: To protect your garments, not every wash/rinse temperature, spin speed, soil level, or option is available with every cycle. A chime will sound and the LED will not light if the selection is not allowed.

- The washer automatically adjusts the wash time for the amount of laundry, water pressure, water heating time and other operating conditions.
- These cycles use various wash motions to enhance cleaning and/or fabric care performance. The wash motions may sound different at different stages of the wash cycle. This is normal.
- Recommended test load size of sanitize course is 10 lbs.

5-3. CYCLE OPTIONS

ADD STEAM



ADD STEAM cycles include the Steam Refresh, Normal/Casual, Bulky/Bedding, Kids Wear, Heavy Duty and Whitest Whites. Adding steam to these cycles provides superior cleaning performance while reducing energy and water consumption. By using a hot steam spray from above and cooler water below, fabrics get the cleaning benefits of a super hot wash, without the energy usage or potential damage to fabrics. The door may become quite warm during steam cycles. This is normal. Do not attempt to override the door lock mechanism or reach into the washer during a steam cycle. Steam can cause severe burns. Steam may not be visible during the steam cycles. This is normal. Do not use steam with delicate fabrics such as wool, silk, or easily discolored fabrics.

DELAY START

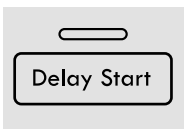

Once you have selected the cycle and other settings, press this button to delay the start of the wash cycle. Each press of the button increases the delay time by one hour, for up to 19 hours. Once the desired delay time is set, press the START/PAUSE button to start the delay time. If the START/PAUSE button is not pressed within 4 minutes, the control will shut off and the settings will be lost.

STAIN TREAT



Use this option for heavily soiled loads that need improved stain treatment. When STAIN TREAT is selected, the water temperature for the selected cycle will begin as warm water to help prevent the setting of certain types of stains. Then as the cycle progresses, the water will be heated to higher temperatures to help remove stains that require treatment at higher temperatures. This option is designed for optimum stain removal.

NOTE: If STAIN TREAT is selected with the SANITIZE cycle, the cycle will begin with very hot water since that is default for that cycle and cannot be changed.

EXTRA RINSE

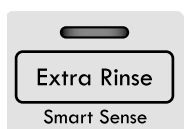

This option will add an extra rinse to the selected cycle. Use this option to help ensure the removal of detergent or bleach residue from fabrics.

PRE WASH

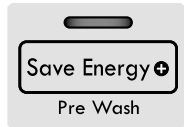

Select this option to add a 16-minute prewash and spin cycle to the chosen cycle.

This is especially useful for heavily soiled items. To use the Pre-Wash feature, press and hold the SAVE ENERGY button for three seconds.

STAY FRESH



This feature helps keep wrinkles from setting in clothes and helps keep them fresh if they are not removed from the washer as soon as the cycle is complete. Press the STAY FRESH button to tumble the clothes intermittently and circulate fresh air through the drum for up to eight hours. Press the POWER button or the START/PAUSE button to remove clothes at any time.

SAVE ENERGY



This option SAVE ENERGY by using cooler water while increasing the wash and rinse times to maintain wash performance. This feature is only available with the NORMAL/CASUAL and HEAVY DUTY cycles as listed below.

- NORMAL/CASUAL - Hot/Cold becomes Warm/Cold
- NORMAL/CASUAL - Warm/Cold becomes Cold/Cold
- HEAVY DUTY - Hot/Cold becomes Warm/Cold

SMART SENSE

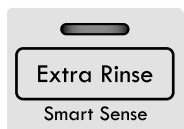

This feature uses a sensor in the drum to check the hardness of the water and the detergent amount. Wash and rinse cycles will be adjusted to optimize wash and rinse performance. To use the SMART SENSE feature, press and hold the EXTRA RINSE button for three seconds.

- Insufficient detergent amount will cause the wash time and temperature to increase.
- Too much detergent will cause the rinse time to increase.
- An excessive amount of detergent will result in extra rinses, to ensure that all detergent is removed from the load.

NOTE: Extra Rinse and Smart Sense cannot be selected at the same time.

5-4. SPECIAL FUNCTION

Clean Washer



A buildup of detergent residue can occur in the wash tub over time and can lead to a mildewy or musty smell. The Clean Washer cycle is specially designed to remove this buildup using bleach or other cleaner designed specifically for cleaning front load washers.

The Clean Washer cycle should be run once a month, or more often under heavy use conditions or if odor is present.

NOTE: Do NOT use this cycle with clothes, and do NOT add detergent or fabric softener.

For powdered tub cleaners, add the cleaner to the main wash compartment of the dispenser drawer. Place tablet cleaners directly into the tub. Always follow the cleaner manufacturers instructions and Recommendations

CONTROL LOCK

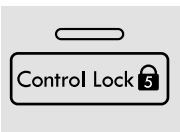

Use this option to disable the controls. The washer can be locked during a cycle. This feature allows you to prevent children from changing cycles or operating the machine. Once set, the CONTROL LOCK must be turned off before the controls can be used. Once the washer has shut off, the power button will allow the machine to be turned on, but the controls will still be locked. When the controls are locked, "CL" will be displayed alternately with the estimated time remaining. Press and hold the CONTROL LOCK button for 5 seconds to activate or deactivate the controls.

MY CYCLE

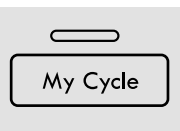

MY CYCLE allows you to store a customized wash cycle for use. It allows you to save favorite temperature, spin speed, soil level, and other options for a cycle, and then recall them at the touch of a button.

NOTE: You can only save a setting for one cycle at a time. Pressing and holding the MY CYCLE button will overwrite any previously saved cycle.

To save a MY CYCLE:

- 1 Press the POWER button to turn on the washer.
- 2 Turn the cycle selector knob to select the desired setting.
- 3 Press the CYCLE MODIFIER button to change the desired setting.
- 4 Press the CYCLE MODIFIER button to add the desired options.
- 5 Press and hold the MY CYCLE button.

To recall a MY CYCLE:

- 1 Press the POWER button to turn on the washer.
- 2 Press the MY CYCLE button. The stored settings will be displayed.
- 3 Press the START / PAUSE button to start the cycle.

NOTE: MY CYCLE can be adjusted the same as any other cycle. However, once any other button is pressed, the LED will turn off indicating that the settings are no longer those of your saved cycle.

AUTO SOAK

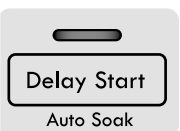

Use the AUTO SOAK option to presoak garments to help remove difficult spots or stains on fabric.

This option provides a 30 minute presoak prior to the start of the selected cycle. At the end of the presoak time, the selected cycle will use the same water.

To use the AUTO SOAK feature, press and hold the DELAY ATART button for three seconds.

DRUM LIGHT

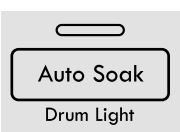

The drum is equipped with a blue LED light that illuminates when the washer is turned ON.

This light automatically turns OFF when the door is closed and the cycle starts. To turn ON the light during a cycle, press and hold AUTO SOAK button for 3 seconds. The drum light will illuminate and then turn OFF automatically after 4 minutes.

5-5. EXPLANATION OF EACH PROCESS

| No. | Process | Explanation |
|---------------|-----------------------------------|---|
| 1. | Stay | <ul style="list-style-type: none"> • Electrical power is supplied • Washer is ready to work and the micom is in the active mode. |
| 2. | Water supply | <ul style="list-style-type: none"> • After loading laundry and selecting a course and a cycle, water is supplied and drum rotates. • When a user selects Pre-wash course, water is supplied through pre wash valve. |
| 3. | Soaking & washing laundry | <ul style="list-style-type: none"> • To get laundry wet, drum rotates clockwise and counterclockwise. • If water amount is insufficient at this time, the Inlet valve will supply water again. |
| 4. | Heating & washing | <ul style="list-style-type: none"> • The heater heats the water in drum to the selected water temperature and drum rotates for washing. |
| 5. ~ 6. | Washing & heating / washing | <ul style="list-style-type: none"> • When the water temperature reaches to the selected temperature, the heating stops and only the drum rotates. • If water temperature becomes lower than selected because of re-supplied water, the heating starts again. |
| 7. | Washing | <ul style="list-style-type: none"> • Fuzzy Logic decides washing time according to the laundry load, water temperature, and other factors. |
| 8. | Drainage | <ul style="list-style-type: none"> • A pump motor drains the water from the drum. • After sensing drained water amount by water level frequency, spin starts. • When a heating course is selected, stay cooling process is performed to decrease the water temperature gradually to prevent laundry from being damaged and for safety reasons. |
| 9. | Untangling (Sensing eccentricity) | <ul style="list-style-type: none"> • It balances laundry load and senses the eccentricity of the load, to only allow spinning without vibration • If the eccentricity is worse than the allowed level, it repeats the disentangling process. When the repeated time is more than allowed level, it displays UE. • If the eccentricity is good, the intermittent spin starts. • During this process, the drain pump works for drainage intermittently. |

| No. | Process | Explanation |
|-----|--------------------|--|
| A. | Intermittent spin | <ul style="list-style-type: none"> To reach the correct set speed, the motor rotates clockwise and counterclockwise directions after spin process starts. If the water level frequency is lower than 23.0 kHz, a washer senses suds and starts suds removal process. |
| B. | Rinse spin | <ul style="list-style-type: none"> In this process, the remaining water during washing process is extracted and the selected speed is kept. Removing suds process is in active mode at this cycle. |
| C. | Remaining spin | <ul style="list-style-type: none"> After spin finishes, the drum rotates by remaining spin power until it stops. Motor power is off. This process is overlapped with next process. |
| D. | Rinse water supply | <ul style="list-style-type: none"> Water supply for rinse process |
| E. | Rinse | <ul style="list-style-type: none"> Rinsing process. |
| F. | Last drainage | <ul style="list-style-type: none"> After spin finishes and power is not supplied to motor, the drum rotates by remaining spin power If rinse hold is selected, the drainage is not proceeded after rinse finishes. |
| G. | Disentangling | <ul style="list-style-type: none"> The same as item 9. |
| H. | Intermittent spin | <ul style="list-style-type: none"> The same as item A. |
| I. | Main spin1 | <ul style="list-style-type: none"> The same as item B. |
| J. | Main spin2 | <ul style="list-style-type: none"> At the end of a main spin, the spin speed will reach the selected rpm. |
| K. | Remaining spin | <ul style="list-style-type: none"> The same with item C. |
| L. | Disentangling | <ul style="list-style-type: none"> After spin finishes, disentangling starts to remove unbalanced laundry. |
| M. | End | <ul style="list-style-type: none"> After 'end' signal is displayed, it stays for 8 seconds and power is automatically turned off. (Auto type door switch) After door switch is off, end signal is displayed in the case of manual type and it takes around 2 minute to turn off door switch. |

6. PROGRAM CHART

PROGRAM CHART

* Water Supply: W-S * Intermittent Spin: I-S * Disentangle: D-T

| CYCLE COURSE | Wash | | | | | | | | | | Rinse | | | | | | | | | | Spin | | | A U T O E N D O F F | **Approx. Working Time (Minutes) | | | | | |
|-----------------|------|-----|------|-----|---|---|--------|-----|----|-----|-------------|-----|-----|-----|-------|------|-----|----|-----|-----|------|----|-----|---------------------------|---|----|-----|----|----|-----|
| | Pre | | Main | | | | Normal | | | | Extra Rinse | | | | Drain | Spin | D-T | | | | | | | | | | | | | |
| | W-S | I-S | W | I-S | W | S | W | I-S | W | I-S | W | I-S | W | I-S | | | | | | | | | | | | | | | | |
| 1 | 2 | 3 | 4 | 5 | 6 | 7 | 8 | 9 | 10 | 11 | 12 | 13 | 14 | 15 | 16 | 17 | 18 | 19 | 20 | 21 | 22 | 23 | 24 | 25 | 26 | 27 | 28 | 29 | 20 | |
| 60 | 60 | 420 | 60 | | | * | 60 | 60 | 60 | 60 | 600 | 120 | 240 | 60 | 420 | 120 | 240 | 60 | 420 | 120 | 240 | 60 | 420 | 120 | 240 | 60 | 360 | 60 | 20 | |
| 8 | 8 | 8 | 8 | 8 | 8 | 8 | 8 | 8 | 8 | 8 | 8 | 8 | 8 | 8 | 8 | 8 | 8 | 8 | 8 | 8 | 8 | 8 | 8 | 8 | 8 | 8 | 8 | 8 | 8 | 20 |
| Steam Refresh | | | | | | | | | | | | | | | | | | | | | | | | | | | | | | |
| Sanitize | | | | | | | 59 | | | | | | | | | | | | | | | | | | | | | | | 113 |
| Bulky /Bedding | | | | | | | 65 | | | | | | | | | | | | | | | | | | | | | | | 63 |
| Workout | | | | | | | 23 | | | | | | | | | | | | | | | | | | | | | | | 118 |
| Wear | | | | | | | 70 | | | | | | | | | | | | | | | | | | | | | | | 60 |
| Normal/Casual | | | | | | | 12 | | | | | | | | | | | | | | | | | | | | | | | 43 |
| Delicates | | | | | | | 15 | | | | | | | | | | | | | | | | | | | | | | | 57 |
| Hand Wash /Wool | | | | | | | 18 | | | | | | | | | | | | | | | | | | | | | | | 15 |
| Express Wash | | | | | | | 25 | | | | | | | | | | | | | | | | | | | | | | | 103 |
| Kid Wear | | | | | | | 2 | | | | | | | | | | | | | | | | | | | | | | | 83 |
| Whitest White | | | | | | | 41 | | | | | | | | | | | | | | | | | | | | | | | 103 |
| Heavy Duty | | | | | | | 47 | | | | | | | | | | | | | | | | | | | | | | | 105 |
| Rugged | | | | | | | 14 | | | | | | | | | | | | | | | | | | | | | | | 20 |
| Rinse + Spin | | | | | | | 20 | | | | | | | | | | | | | | | | | | | | | | | 68 |
| Cold Clean | | | | | | | 47 | | | | | | | | | | | | | | | | | | | | | | | |
| | | | | | | | 52 | | | | | | | | | | | | | | | | | | | | | | | |
| | | | | | | | 51 | | | | | | | | | | | | | | | | | | | | | | | |
| | | | | | | | 57 | | | | | | | | | | | | | | | | | | | | | | | |
| | | | | | | | 14 | | | | | | | | | | | | | | | | | | | | | | | |
| | | | | | | | 20 | | | | | | | | | | | | | | | | | | | | | | | |

Basic Cycle
 Optional Cycle
 Pre-Setting Time : Water Supply - 60 sec.
 Drain - 60 sec.

* Wash time is in minutes.
 ** The total working time will vary with the load size, water temperature and ambient temperature.



7. TEST MODE

7-1. SAFETY CAUTION

- There's built-in AC 110V and DC power in output terminal of PWB assembly in common. Be careful electric shock when disconnecting parts while trouble shooting. (Wear Electro Static Discharge gloves when working.)
- After cutting off the power when changing PWB assembly, disconnect or assemble.
- Be careful static when handling PWB assembly, and use Electro Static Discharge plastic pack when delivering or keeping it.

7-2. LOAD TEST MODE.

The washer must be empty and the controls must be in the off state.

1. Press the SPIN SPEED and SOIL LEVEL buttons simultaneously.
2. Press the POWER  button, while the above condition. Then buzzer will sound twice.
3. Press the Steam button.
4. Press the START/PAUSE  button repeatedly to cycle through the test modes.

| Number of times the Start/Pause button is pressed | Check Point | Display Status |
|---|-------------------------------------|---|
| None | Turns on all lamps. | LOAD TEST MODE |
| 1 time | Tumble clockwise. | rpm (42~50) |
| 2 times | Low speed Spin. | rpm (35~45) |
| 3 times | High speed Spin. | rpm (110~117) |
| 4 times | Inlet valve for prewash turns on. | Water level frequency (0~255) |
| 5 times | Inlet valve for main wash turns on. | Water level frequency (0~255) |
| 6 times | Inlet valve for Hot water turns on. | Water level frequency (0~255) |
| 7 times | Inlet valve for bleach turns on. | Water level frequency (0~255) |
| 8 times | Inlet valve for steam turns on. | Water level frequency (0~255) |
| 9 times | Tumble counterclockwise. | rpm (42~50) |
| 10 times | Heater turns on for 3 seconds. | Water temperature |
| 11 times | Circulation pump turns on. | Water level frequency (0~255) |
| 12 times | Drain pump turns on. | Water level frequency (0~255) |
| 13 times | Steam water level sensor operates. | AG tub water level frequency (0~255) |
| 14 times | Steam Heater turns on for 1.2 sec. | |
| 15 times | Vibration sensor check | - None error (bs0) - Main vibration error (bs1) - Display vibration error (bs2) - Both error (bs3) |
| 16 times | off | |

NOTES:

- RPM < 220 : RPM = display / RPM > 200 : RPM = display X 10
- WATER LEVEL : o255 = empty / o248 = normal / o255 = tub clean

7-3. HOW TO CHECK THE WATER LEVEL FREQUENCY

- * Press the WASH/RINSE and DELAY START button simultaneously.

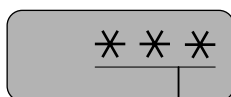

- The digits indicate the water level frequency (x.1 kHz).

So, for example a display indicating 241: a Water level frequency of 241 x.1 kHz
= 24.1 kHz

8. TROUBLESHOOTING

8-1. SAFETY CAUTION

- There's built-in AC 120V and DC power in output terminal of PWB assembly in common. Be careful electric shock when disconnecting parts while trouble shooting. (Wear Electro Static Discharge gloves when working.)
- After cutting off the power when changing PWB assembly, disconnect or assemble.
- Be careful static when handling PWB assembly, and use Electro Static Discharge plastic pack when delivering or keeping it.

8-2. ERROR MODE SUMMERY

- If you press the START/PAUSE button when an error is displayed, any error except 『PE』 will disappear and the machine will go into the pause status.
- In case of 『PE』, 『LE』, 『dE』 if the error is not resolved within 20 sec., or the in case of other errors, if the error is not resolved within 4 min., power will be turned off automatically and the error code will blink. But in the case of 『FE』, power will not be turned off.

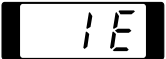
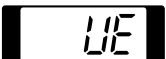
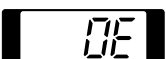
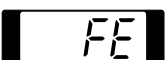
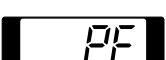
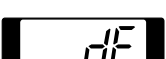
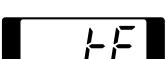
| | ERROR | SYMPTOM | CAUSE |
|---|-----------------------|---|---|
| 1 | WATER INLET ERROR |  | <ul style="list-style-type: none"> • Correct water level (246) is not reached within 8 minutes after water is supplied or it does not reach the preset water level within 25 minutes. |
| 2 | UNBALANCE ERROR |  | <ul style="list-style-type: none"> • The load is too small. • The appliance is tilted. • Laundry is gathered to one side. • Non distributable things are put into the drum. |
| 3 | DRAIN ERROR |  | <ul style="list-style-type: none"> • Not fully drained within 10 minutes. |
| 4 | OVER FLOW ERROR |  | <ul style="list-style-type: none"> • Water is overflowing (water level frequency is over 213). ※ If 『FE』 is displayed, the drain pump will operate to drain the water automatically. |
| 5 | PRESSURE SENEOR ERROR |  | <ul style="list-style-type: none"> • The SENSOR SWITCH ASSEMBLY is out of order. |
| 6 | DOOR OPEN ERROR |  | <ul style="list-style-type: none"> • Door not all the way closed. • Loose electrical connections at Door switch and PWB Assembly. • The DOOR SWITCH ASSEMBLY is out of order. |
| 7 | HEATING ERROR |  | <ul style="list-style-type: none"> • The THERMISTOR is out order. |

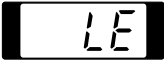
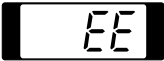
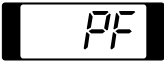
| | ERROR | SYMPTOM | CAUSE |
|----|--------------------|---|---|
| 8 | LOCKED MOTOR ERROR |  | <ul style="list-style-type: none"> • The connector (3-pin, male, white) in the MOTOR HARNESS is not connected to the connector (3-pin, female, white) of STATOR ASSEMBLY. • The electric contact between the connectors (3-pin, male, white) in the MOTOR HARNESS and 4-pin, female, white connector in the MAIN PWB ASSEMBLY is bad or unstable. • The MOTOR HARNESS between the STATOR ASSEMBLY and MAIN PWB ASSEMBLY is cut (open circuited). • The hall sensor is out of order/defective. |
| 9 | EEPROM ERROR |  | <ul style="list-style-type: none"> • EEPROM is out of order. ※ Displayed only when the START/PAUSE button is first pressed in the QC Test Mode. |
| 10 | POWER FAILURE |  | <ul style="list-style-type: none"> • The washer experienced a power failure. |

8-3. TROUBLESHOOTING SUMMARY

CIRCUIT DIAGRAM

※ Reference
 Part Name ※
 The part of this mark is only for steam models.

| Result (tolerance ± 5%) | Remarks |
|-------------------------|------------------|
| 39.5 kΩ | At 86°F (30°C) |
| 26.1 kΩ | At 104°F (40°C) |
| 12.1 kΩ | At 140°F (60°C) |
| 8.5 kΩ | At 158°F (70°C) |
| 3.8 kΩ | At 203°F (95°C) |
| 2.8 kΩ | At 221°F (105°C) |

| Result (tolerance ± 5%) | Remarks |
|-------------------------|------------------|
| 39.5 kΩ | At 86°F (30°C) |
| 26.1 kΩ | At 104°F (40°C) |
| 12.1 kΩ | At 140°F (60°C) |
| 8.5 kΩ | At 158°F (70°C) |
| 3.8 kΩ | At 203°F (95°C) |
| 2.8 kΩ | At 221°F (105°C) |
| 2.1 kΩ | At 241°F (116°C) |
| 1.4 kΩ | At 266°F (130°C) |
| 1.0 kΩ | At 293°F (145°C) |
| 0.7 kΩ | At 320°F (160°C) |
| 0.4 kΩ | At 356°F (180°C) |

| Test Points | Result |
|-------------|--------|
| (1) to (2) | 5-15 Ω |
| (2) to (3) | 5-15 Ω |
| (3) to (1) | 5-15 Ω |

| Test Points | Result | Remarks |
|-------------|-----------|----------------|
| (1) to (2) | 8-12 kΩ | |
| (1) to (3) | 8-12 kΩ | |
| (1) to (4) | 10-15 Vdc | Voltage Input |
| (2) to (4) | 10 Vdc | Pulsing Signal |
| (3) to (4) | 10 Vdc | Pulsing Signal |

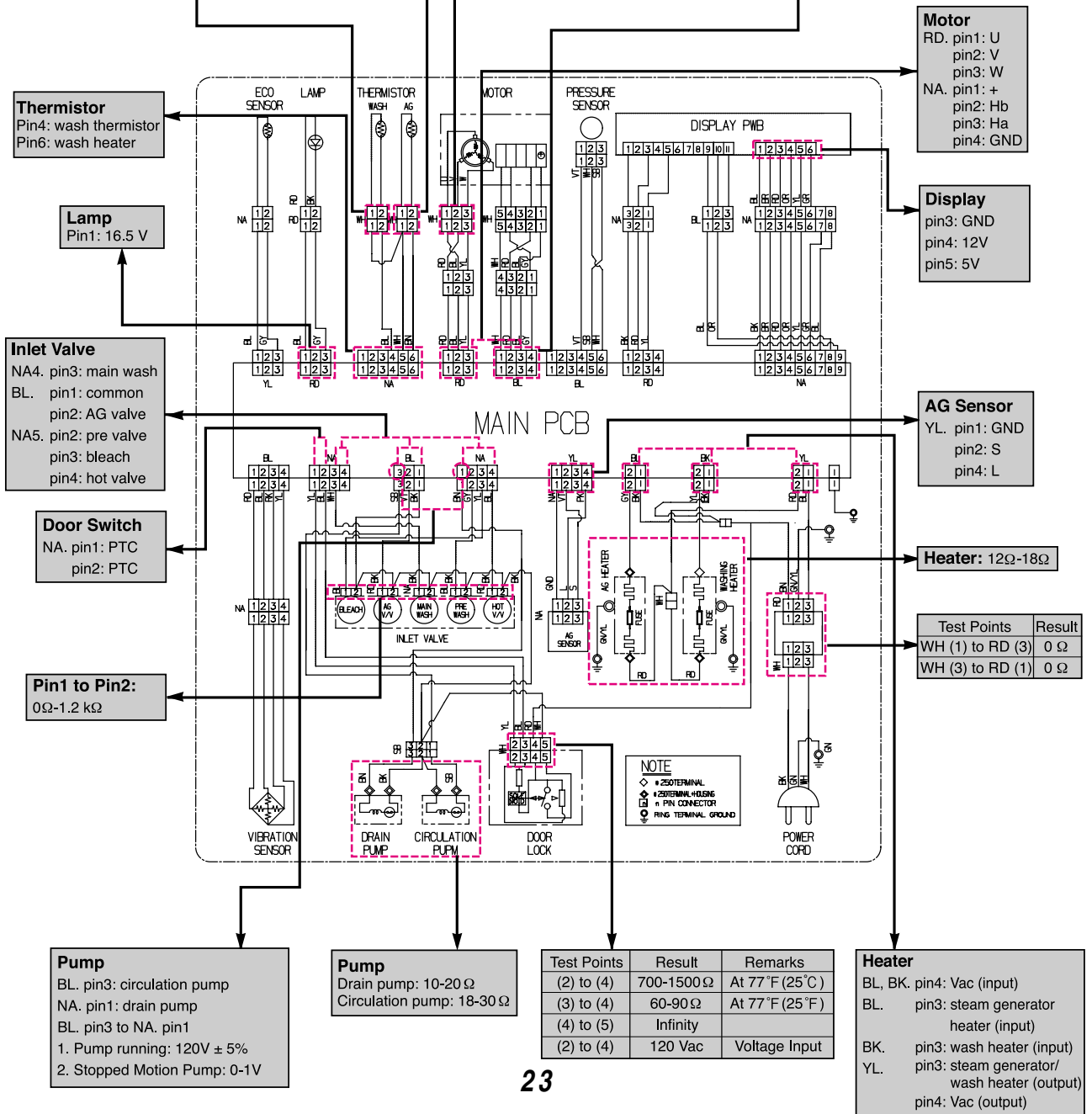

CIRCUIT DIAGRAM

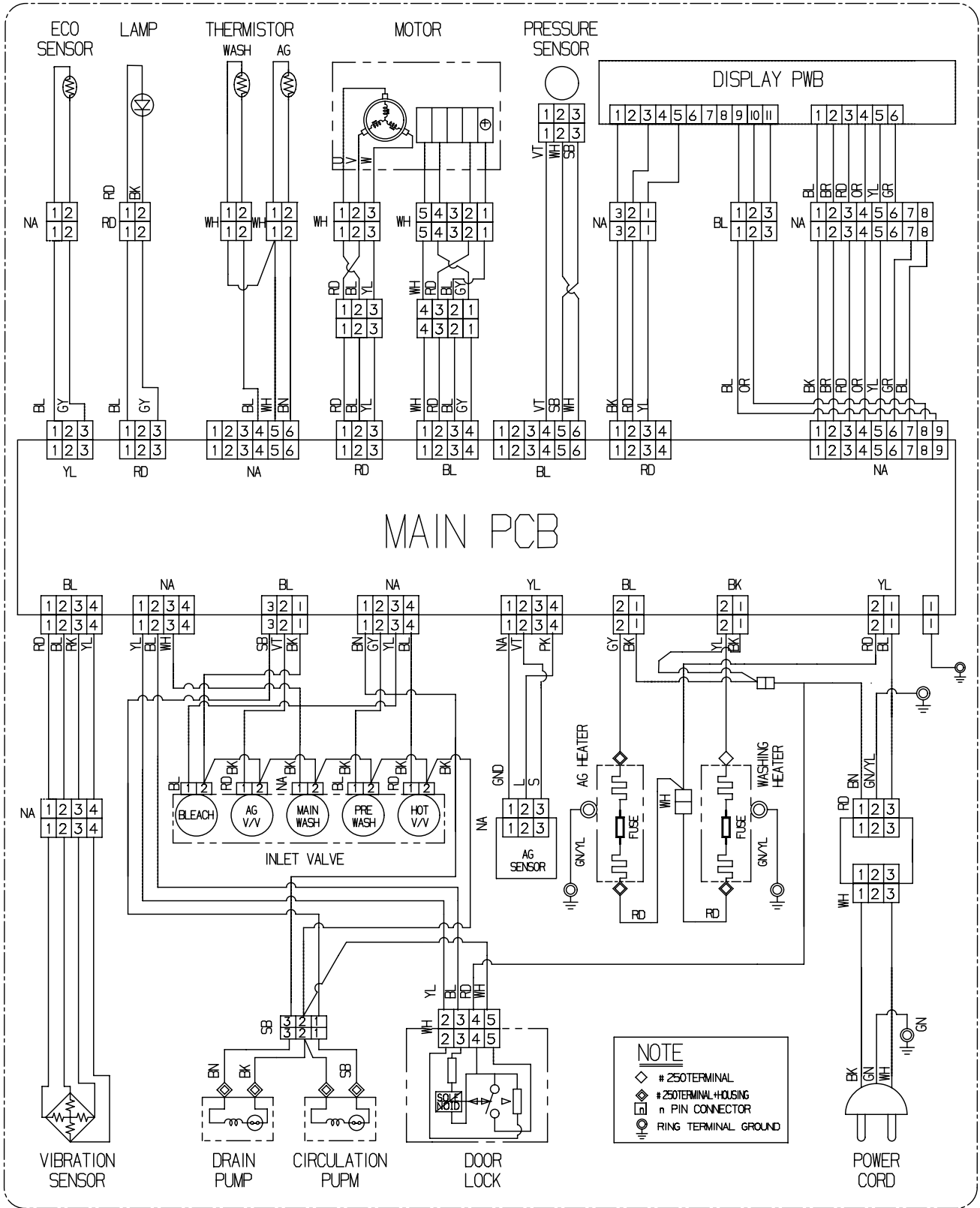

8-4. TROUBLESHOOTING WITH ERROR

INLET VALVE ERROR

Is **IE** displayed?

Yes

When you press both **WASH/RINSE** button and **DELAY STRAT** button simultaneously, is the water level < 246?

Yes

Check the AIR CHAMBER and the tube (clogged).

No

Is filter inlet valve clogged with foreign material?

Yes

Clean or replace the filter.

No

Check the connectors at the main PCB and the water valve. Are the connectors loose or disconnected?

Yes

Reconnect or repair the connector.

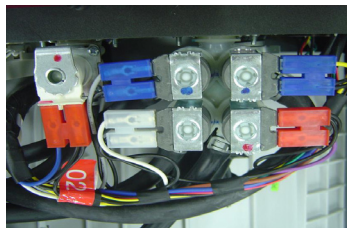

No

Is the resistance of fill valve coil between 800 and 1200 Ω ?
(Refer to 9-5 inlet valve assembly.)

No

Replace the INLET VALVE ASSEMBLY.

Yes

Proceed to next step at right.

Is the voltage at the inlet valve coil 120VAC with the valve energized?

Yes

Replace the INLET VALVE ASSEMBLY.

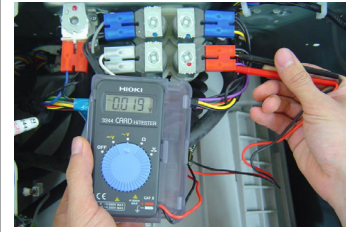

No

Is the wiring correct? Refer to the wiring diagram for correct connections.
(Refer to 9-5 wiring diagram)

No

Replace the MAIN HARNESS.

Yes

Is the water level still < 246?

Yes

Check the pressure switch. Refer to test #2.

No

Replace the MAIN PWB ASSEMBLY.

ALWAYS CHECK FOR EXTERNAL CAUSES

- Water supply shut off
- Frozen water lines
- Kinked fill hose
- Low water pressure

DRAIN ERROR

Is DE displayed?

Yes

Check the connectors at the main PCB and the drain pump. Are the connectors loose or disconnected?

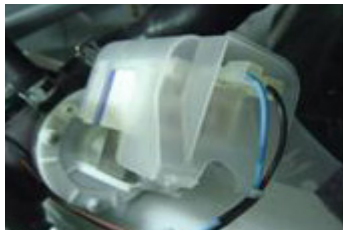

Circulation pump



Drain pump



Connection connector

Yes

Reconnect or repair the connector.

No

When you press both **WASH/RINSE** button and **DELAY START** button simultaneously, is the water level <250?

Yes

Proceed to next step at right

No

Check the air dome and pressure hose for clogging. Check the pressure switch. See test #2.

Measure the resistance of the drain pump motor. Is the resistance between 10Ω and 20Ω ?
(Refer to 9-4 Pump motor assembly.)

Yes

Replace the DRAIN PUMP ASSEMBLY.

No

Check the voltage between the main PCB connectors NA4-1 BN and BL3-1 BK. Is the voltage 120 VAC ± 5%?

No

Replace the MAIN PWB ASSEMBLY.

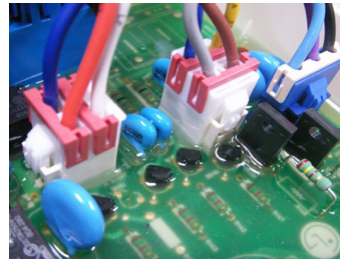

TO TURN ON THE DRAIN PUMP:

1. Turn on the washer
2. Press the SPIN SPEED button to select LOW speed.
3. Press the START/PAUSE button.
The drain pump will be energized for several minutes at the beginning of the spin cycle.

ALWAYS CHECK FOR EXTERNAL CAUSES

- Kinked or clogged drain hose
- Frozen drain hose
- Foreign objects clogging the drain pump filter
- Foreign objects caught in pump impeller

HEATING ERROR

Is **EE** displayed?

Yes

Check the connectors at the main PCB, the heater and the thermistor. Are the connectors loose or disconnected?

Reconnect or repair the connector.

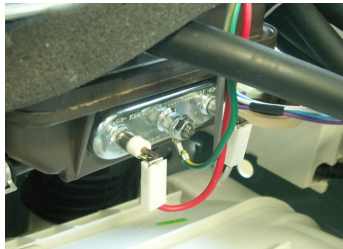

Steam generator heater

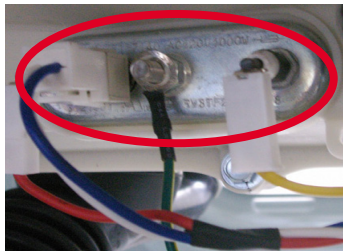

Wash heater

No

Check the resistance of the heater. Is the resistance between 12Ω and 18Ω ? (Refer to 9-6 Heater assembly.)

No

Replace the HEATER ASSEMBLY.

Yes

Proceed to next step at right

Is the connector connected to thermistor disconnected or disassembled?

Yes

Reconnect or repair the connector.

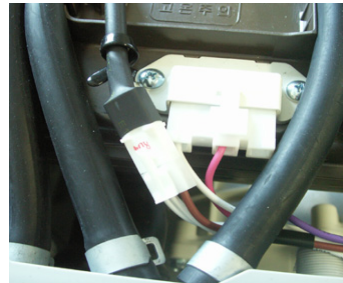

Steam generator thermistor

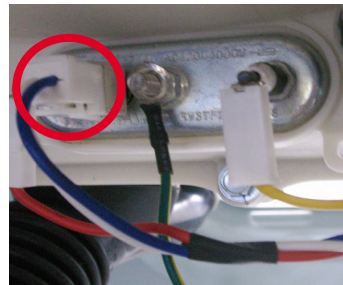

Wash thermistor

No

Check the thermistor resistance. Is the resistance correct according to the chart? (Refer to 9-7 thermistor assembly.)

Yes

Replace the THERMISTOR ASSEMBLY.

No

Are the thermistor terminals dry and free of corrosion?

Yes

Replace the THERMISTOR ASSEMBLY.

[Note]

The temperature sensing circuits on the main PCB are very simple, consisting only of resistors and capacitors. Problems with wiring or connections in the thermistor circuit are the most likely cause for this error. Be sure to check ALL connections and wiring thoroughly. The main PCB should only be replaced as a last resort, as it is unlikely to be the cause.

LOCKED MOTOR ERROR

Is **LE** displayed?

Yes

Check the connectors at the main PCB and the main motor. Are the connectors loose or disconnected?
Main PCB connectors RD3 and NA4
Motor connectors to stator and hall sensor

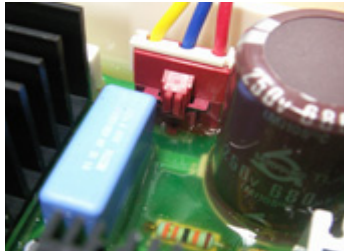

Motor Drive

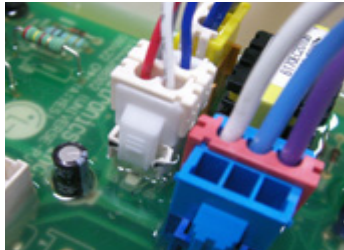

Hall sensor

- part of wire



Motor Drive Hall Sensor

Yes

Reconnect the connector. (connector / wire / motor)

- part of motor



Motor

Yes

Check the resistance of the stator winding from the main PCB connector RD3. Is the resistance between each pair or wires between 5 and 15 ? (Measure pins 1-2, 1-3 and 2-3.)

No

Replace the STATOR.



Yes

Is hall sensor out of order? (Refer to 9-3 Stator assembly/Hall sensor.)

Yes

Replace the Hall sensor.

No

Check the IPM in the controller.

No

Replace the MAIN PWB ASSEMBLY.

Is rotor magnet cracked?



Magnet

Yes

Replace the ROTOR.

DOOR OPEN ERROR

Is **dE** displayed?

Yes

Check the connectors at the main PCB and the door switch. Are the connectors loose or disconnected?



Yes

Reconnect or repair the connector

No

Is the door closing properly?
Is the gasket damaged and interfering with the door or latch?
Are there foreign objects caught in the door?
Is the hinge damaged?

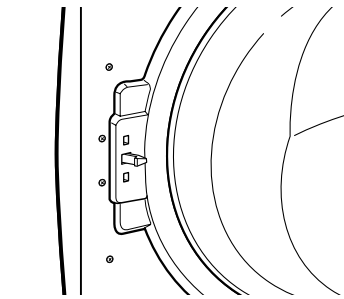
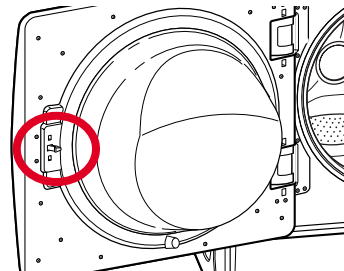

No

Replace Door Assembly

Yes

Proceed to next step at right

Is the spring in the door latch hook on the door strong and tight?

No

Replace gasket or hinge.
Remove foreign objects.

Yes

Can you hear the door latch attempting to lock the door at the beginning of the cycle or diagnostic mode?

No

Replace the PCB ASSEMBLY.

Yes

If tested off the stator using the diagram above ohm check the resistors from pin 5 to pin 1 & pin 2. Does either test show an open (infinity) the hall sensor? (You should measure approximately 10,000 ohms from pin 5 to pin 1 and 10,000 ohms from pin 5 to pin 2)

No

Replace the DOOR SWITCH ASSEMBLY.

UNBALANCE ERROR

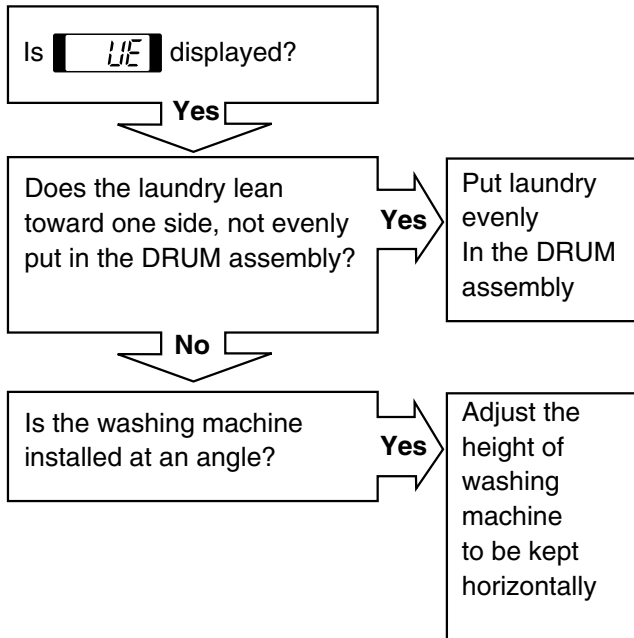

[Note] Environmental check list

- 1) Removal of transportation-based fixed bolt.
- 2) Confirmation on the material to see if it is capable of handling two different types of blanket materials.

OVER FLOW ERROR

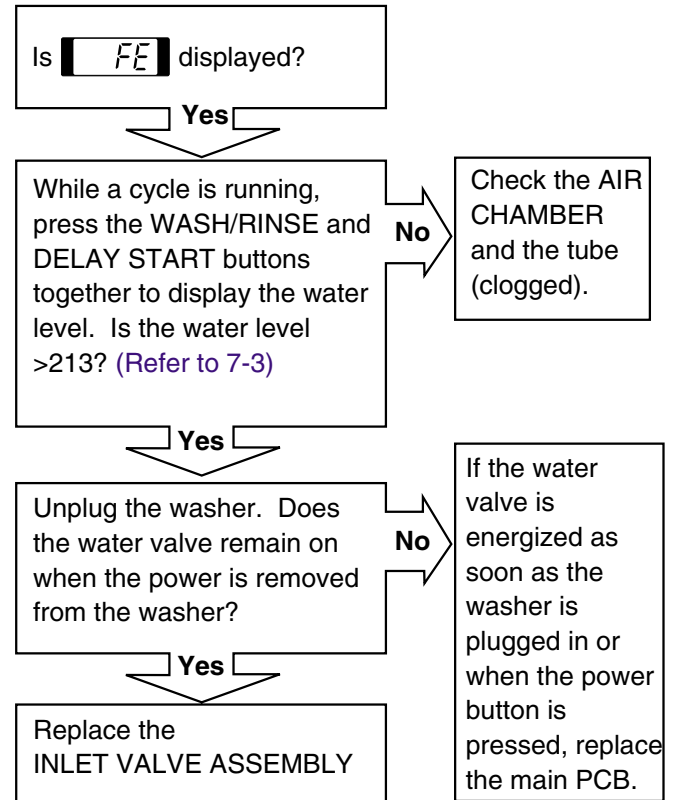

PRESSURE SENSOR ERROR

Is **PE** displayed?

Yes

Check the connectors at the main PCB and the pressure switch. Are the connectors loose or disconnected?



Yes

Reconnect or repair the connector

No

Measure the resistance between pins 1 and 3 of the pressure switch. Is the resistance between 21Ω and 23Ω ?



No

Replace the pressure switch

Yes

Is the AIR CHAMBER and the tube clogged?

Yes

Fix the air chamber and remove the foreign material.

No

Replace the MAIN PWB assembly.

8-5. TROUBLE SHOOTING ELSE

⚠ CAUTION

1. Be careful of electric shock if disconnecting parts while troubleshooting.
2. First of all, check the connection of each electrical terminal with the wiring diagram.
3. If you replace the MAIN PWB ASSEMBLY, reinsert the connectors correctly.

NO POWER

Is the supplied voltage 120V AC?(+10%, -15%)

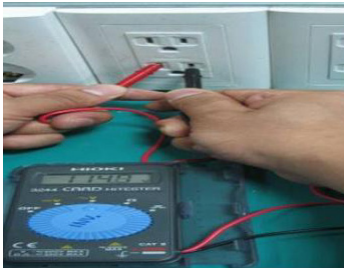

No → Check the fuse or reset the circuit breaker

Yes →

Is the current rating of multi-outlet power strip enough?
(Avoid connecting several electric devices.)



No → Alternate with explanation

Yes →

Check the connectors at the main PCB and the line filter. Are the connectors loose or disconnected?

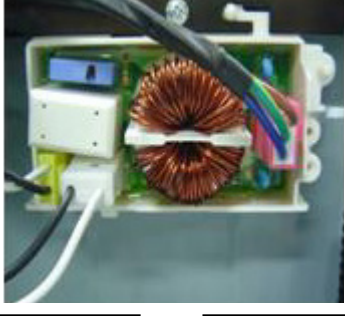

Yes → Reconnect or repair the connector

No →

Is LED on while the power is on?

No → Replace the MAIN PWB ASSEMBLY

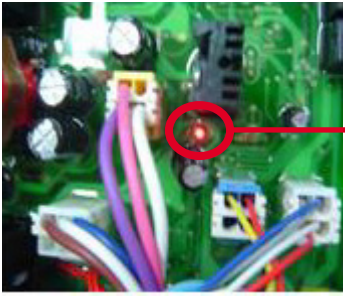

Main LED

Yes →

Is three pin wire of display PWB broken?

No → Replace the DISPLAY PWB ASSEMBLY

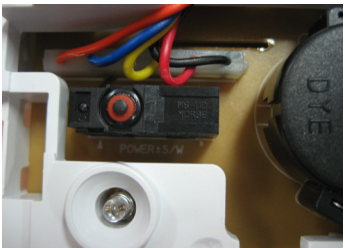

Display PWB

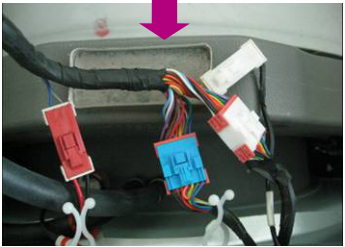
Connecting connector MAIN PWB~ Display PWB

BUTTON DOESN'T WORK

Check the connectors at the main PCB and the line filter. Are the connectors loose or disconnected?

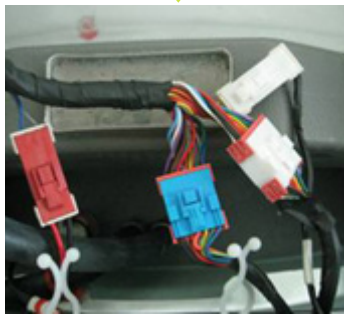
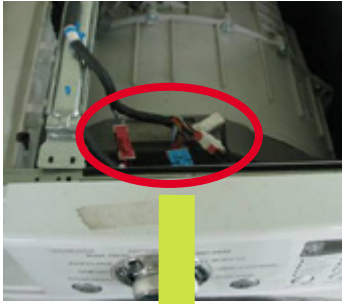

Yes

Reconnect or Repair the connector

No

Check the connectors between the main PCB and the display PCB. Are the connectors loose or disconnected?

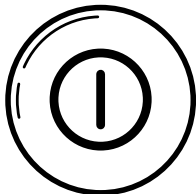

POWER

Yes

Replace the main PCB.

No

Replace the main PCB.

VIBRATION & NOISE IN SPIN

Have all the transit bolts and base packing been removed?

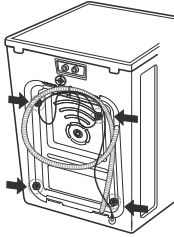

Base Packing

No

Remove the transit bolts and Base packing.

Is the washer installed on a solidly constructed floor?

Yes

No

Move the washer or reinforce the floor.

Check if the washer is perfectly level as follows:

Check the leveling of the washer with a level and check that the washer is stable.

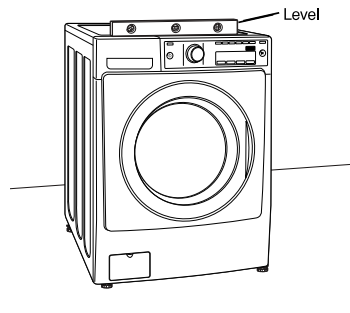

Put an unbalance part (rubber) inside of drum and start QC test mode and run in high spin. (Refer to section 7-2.) When the machine is spinning in high speed, verify that it is stable.

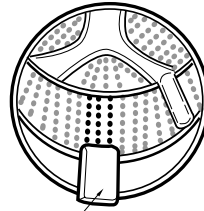

Unbalance Part

If you do not have the unbalance part, put 4.5 to 6.5 lbs (2 to 3 kg) of clothing. Once loaded, press power, Rinse+Spin and the start/pause button in sequence. When the machine is spinning in high speed, verify that it is stable.

Yes

If it is not stable, adjust feet accordingly. After the washer is level, tighten the lock nuts up against of the base of the washer. All lock nuts must be tightened.

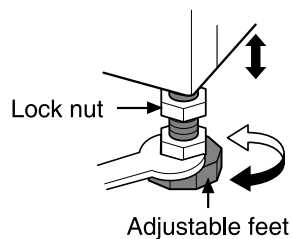

Yes

Check the vibration Sensor.

DETERGENT DOES NOT FLOW IN

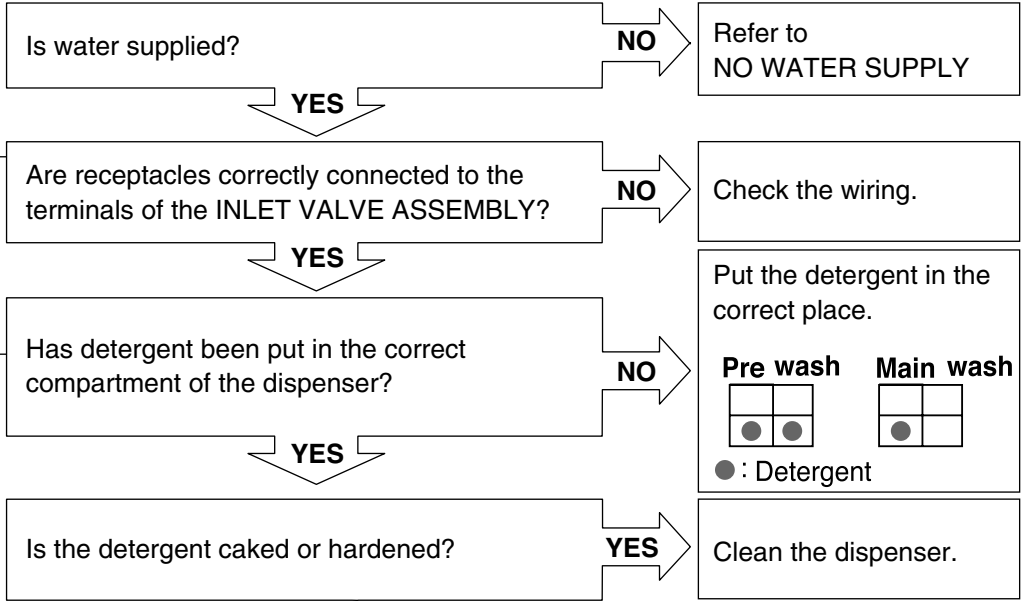
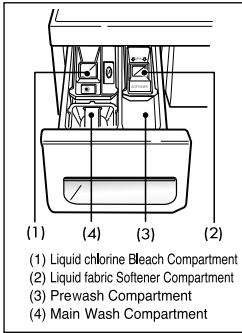
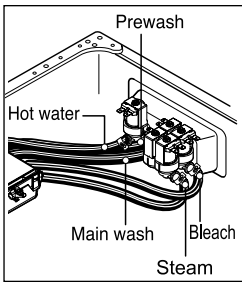

LIQUID DETERGENT/SOFTENER/BLEACH DOES NOT FLOW IN

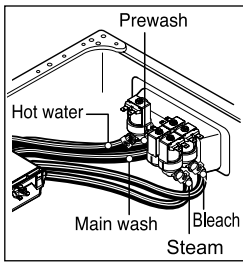

Is water supplied?

NO

Refer to
NO WATER SUPPLY

YES

Are the plugs correctly connected to the terminals of the INLET VALVE ASSEMBLY?

NO

Check the wiring on the dispenser.

YES

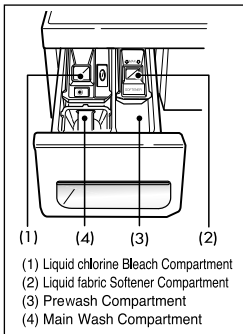

Is liquid detergent/softener/bleach put in the correct compartment of the drawer?

NO

Put it in the correct compartment.

YES

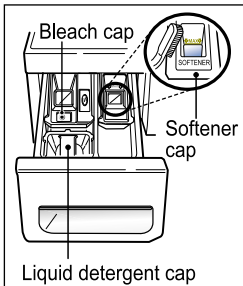

Is the liquid detergent/softener/bleach cap clogged?

YES

Clean the cap and Container.

ABNORMAL SOUND

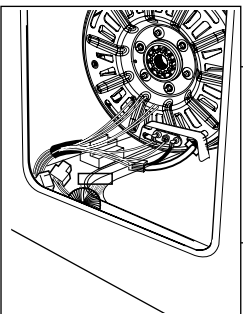

Is the motor bolt loosened?

YES

Secure the bolt.

NO

Is there friction noise coming from the motor?

YES

Check hall sensor.
Replace If defective.
Then check stator.
Replace if necessary.
Check rotor for broken magnets.
Replace rotor if necessary.

9. COMPONENT TESTING INFORMATION

⚠ WARNING When Resistance (Ohm) checking the Component, be sure to turn the power off, and do voltage discharge sufficiently.

9-1. FILTER ASSEMBLY (LINE FILTER)

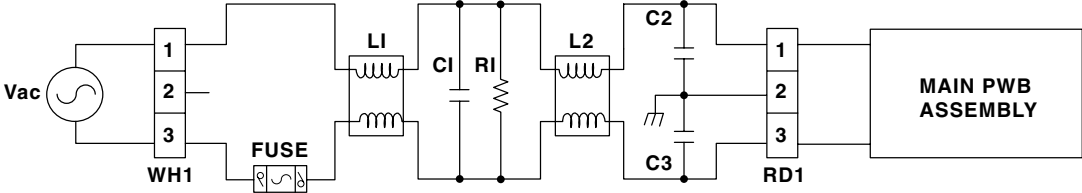
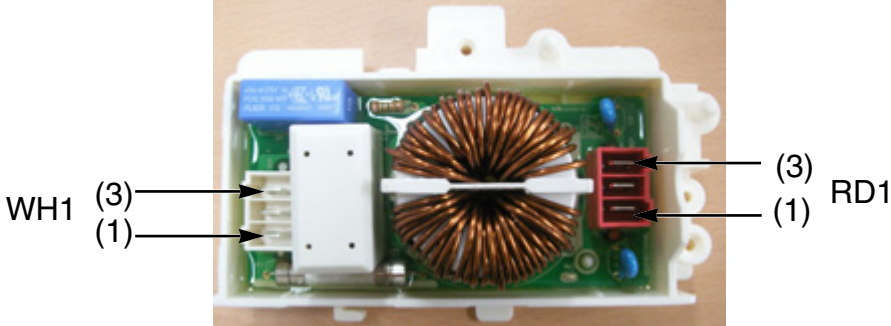
| <p>Circuit diagram</p> | <p style="text-align: center;">Circuit in the MAIN PWB / Circuit diagram</p>  | | | | | | |
|--------------------------------------|--|-------------|--------|------------------|-----|------------------|-----|
| <p>Test points and Result</p> |  <table border="1" data-bbox="678 1344 1157 1500"> <thead> <tr> <th>Test Points</th> <th>Result</th> </tr> </thead> <tbody> <tr> <td>WH (1) to RD (3)</td> <td>0 Ω</td> </tr> <tr> <td>WH (3) to RD (1)</td> <td>0 Ω</td> </tr> </tbody> </table> | Test Points | Result | WH (1) to RD (3) | 0 Ω | WH (3) to RD (1) | 0 Ω |
| Test Points | Result | | | | | | |
| WH (1) to RD (3) | 0 Ω | | | | | | |
| WH (3) to RD (1) | 0 Ω | | | | | | |

9-2. DOOR LOCK SWITCH ASSEMBLY

| | |
|-------------------------------|--|
| <p>Circuit diagram</p> | <p style="text-align: center;">Circuit in the MAIN PWB / Circuit diagram</p> |
| <p>Function</p> | <p>The Door Lock Switch Assembly consists of a Heating PTC, a Bimetal, a Protection PTC, and a Solenoid. It locks the door during a wash cycle.</p> <ol style="list-style-type: none"> 1. Operation for door closing <ul style="list-style-type: none"> - After the system turns on, PTC heating starts up through terminal 2~4's authorizing the power on. - After PTC heating starts up and before solenoid operation is driven, force the system to the off position through CAM. ⇒ Door close - Authorizing one impulse through terminal 3~4 (PTC & solenoid) will make the door locked. - Door lock is detected when switches in terminal 4~5 are set closed. ⇒ CAM rotation will forcibly clear off the connection. The maximum, allowable number of impulse authorizations is 2 ⇒ Upon the third authorization of the impulse, the position of CAM goes back to the door-open position. - Authorizing the impulse occurs in 4.5 seconds upon input for max performance and two authorization processes are allowed at most. ⇒ Normal operation period of PTC heating: 1.5 - 5 seconds (Defects from the development process) 2. Operation for door opening <ul style="list-style-type: none"> - With a temporary stop, door automatically opens by CAM rotations after authorizing the impulse from the terminal 3 ~ 4 and the power turns off - maximum of 3 times of the authorizing period - Upon the fourth authorization of the impulse, the position of CAM goes back to the door-close position. |

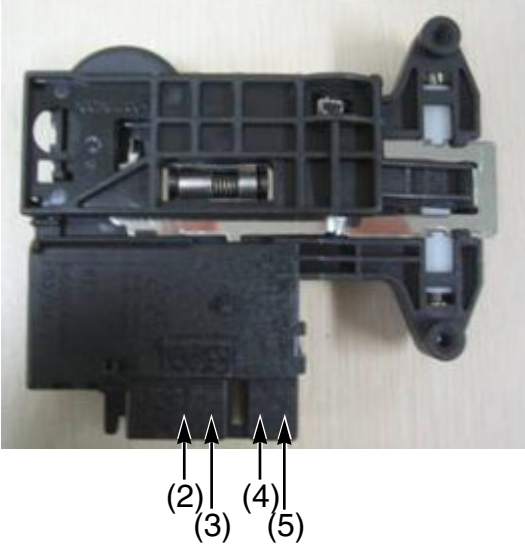
| <p>Test points</p> |  | | | | | | | | | | | | | | | |
|---------------------------|---|----------------|--------|---------|------------|-------------------|----------------|------------|----------------|----------------|------------|----------|--|------------|---------|---------------|
| <p>Result</p> | <table border="1"> <thead> <tr> <th>Test Points</th> <th>Result</th> <th>Remarks</th> </tr> </thead> <tbody> <tr> <td>(2) to (4)</td> <td>700-1500 Ω</td> <td>At 77°F (25°C)</td> </tr> <tr> <td>(3) to (4)</td> <td>60-90 Ω</td> <td>At 77°F (25°C)</td> </tr> <tr> <td>(4) to (5)</td> <td>Infinity</td> <td></td> </tr> <tr> <td>(2) to (4)</td> <td>120 Vac</td> <td>Voltage Input</td> </tr> </tbody> </table> | Test Points | Result | Remarks | (2) to (4) | 700-1500 Ω | At 77°F (25°C) | (3) to (4) | 60-90 Ω | At 77°F (25°C) | (4) to (5) | Infinity | | (2) to (4) | 120 Vac | Voltage Input |
| Test Points | Result | Remarks | | | | | | | | | | | | | | |
| (2) to (4) | 700-1500 Ω | At 77°F (25°C) | | | | | | | | | | | | | | |
| (3) to (4) | 60-90 Ω | At 77°F (25°C) | | | | | | | | | | | | | | |
| (4) to (5) | Infinity | | | | | | | | | | | | | | | |
| (2) to (4) | 120 Vac | Voltage Input | | | | | | | | | | | | | | |

9-3. STATOR ASSEMBLY

| <p>Circuit diagram</p> | <p style="text-align: center;">Circuit in the MAIN PWB / Circuit diagram</p> | | | | | | | | |
|--------------------------------------|--|-------------|--------|------------|--------|------------|--------|------------|--------|
| <p>Function</p> | <p>The DD motor can be driven from stopped to maximum speed in infinite steps in either direction. There are 36 poles on the stator; 12 permanent magnets spaced around the rotor. There are no brushes to wear out. Unlike a more traditional brushless motor, the rotor surrounds the stator rather than being attached to it.</p> | | | | | | | | |
| <p>Test points (Windings)</p> | | | | | | | | | |
| <p>Result (Windings)</p> | <table border="1" style="margin-left: auto; margin-right: auto;"> <thead> <tr> <th>Test Points</th> <th>Result</th> </tr> </thead> <tbody> <tr> <td>(1) to (2)</td> <td>5-15 Ω</td> </tr> <tr> <td>(2) to (3)</td> <td>5-15 Ω</td> </tr> <tr> <td>(3) to (1)</td> <td>5-15 Ω</td> </tr> </tbody> </table> | Test Points | Result | (1) to (2) | 5-15 Ω | (2) to (3) | 5-15 Ω | (3) to (1) | 5-15 Ω |
| Test Points | Result | | | | | | | | |
| (1) to (2) | 5-15 Ω | | | | | | | | |
| (2) to (3) | 5-15 Ω | | | | | | | | |
| (3) to (1) | 5-15 Ω | | | | | | | | |

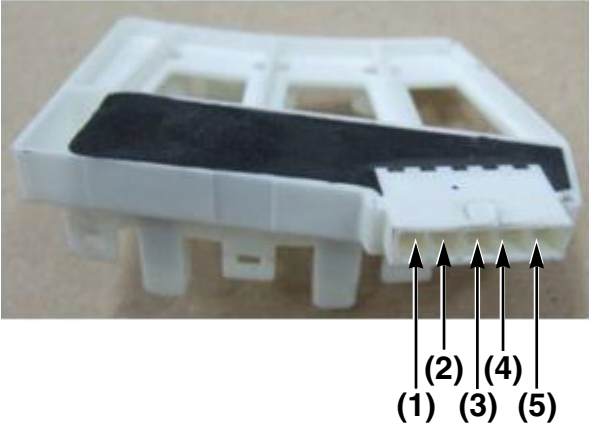
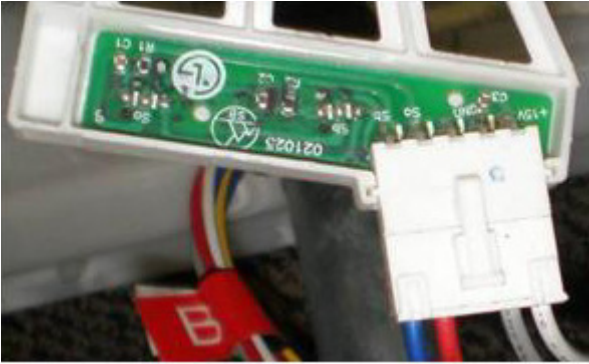
| | |
|--|--|
| | <p>The hall sensor determines the speed and direction of the motor. It also can read that the load is off balance when the drum speed fluctuates.</p> |
| <p>Test point and Result (Hall Sensor)</p> | <p>- Voltage Testing Hall Sensor at Stator</p> <div style="text-align: center;">  </div> <div style="text-align: center;">  </div> <p>If measuring voltage from the Main PCB Assembly to the Hall Sensor, use the following steps:</p> <ol style="list-style-type: none"> 1. Unplug power cord. 2. Remove rear washer panel. 3. Locate Hall sensor connector on the stator behind the rotor. 4. Place meter leads on terminals 5 to 4, white to gray. 5. Plug in power cord, close door, and press power button. DO NOT PRESS START! 6. You should measure 10 to 15 Vdc. If 10 to 15 Vdc is present, control board, white wire, and gray wire are OK! If not follow testing output voltages on control board in next section. |

7. To measure output signal voltage from the hall sensor, carefully move test leads to terminals 1 to 4, blue and gray. Slowly rotate motor rotor by hand. You should read a pulsing 10 Vdc. If 10 Vdc is measured from 1 to 4, move lead on blue wire to red wire, terminal 2. Repeat rotating motor rotor by hand. You should read a pulsing 10 Vdc from red to gray.
8. If pulsing 10 Vdc is measured from 1 to 4 and 2 to 4, hall sensor is OK! If either test netted only 9 to 10 Vdc without changing (no pulsing) the hall sensor is likely defective. Disconnect power by unplugging washer and ohm check hall sensor to verify failure of the hall sensor.

**Test Point
and
Result
(Hall
Sensor)**

- Voltage Testing Hall Sensor from the Main PCB Assembly

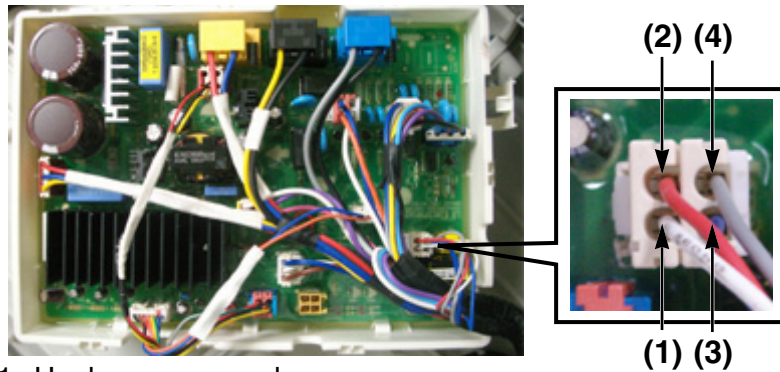

1. Unplug power cord.
2. Remove rear panel.
3. Remove Washer Top.
4. Remove Main PCB Assembly cover as shown in Figure below.
5. Locate the white Hall Sensor 4 wire connector using wiring diagram wire colors as your guide.
6. Plug in power cord, close door, and press power button. **DO NOT PRESS START!**
7. Place meter leads on White & Gray wires. You should read 10 to 15 Vdc output from the Main PCB Assembly to the Hall sensor. If no 10 to 15 Vdc is measured the control board is defective.
8. Place meters leads on Blue to Gray. Turn motor rotor slowly by hand. You should measure a pulsing 10 Vdc. Place meter leads on Red to Gray. Turn motor rotor slowly by hand. You should measure a pulsing 10 Vdc. If both tests measure a pulsing 10 Vdc, hall sensor and harness OK. If either or both tests measures 9 to 10 volts, but does not pulse or change, Hall sensor has failed and must be replaced. IF zero (0) voltage is measured on either test, check red & blue wires for continuity. Repair or replace harness as needed.

| Test Points | Result | Remarks |
|-------------|-----------|----------------|
| (1) to (2) | 8-12 kΩ | |
| (1) to (3) | 8-12 kΩ | |
| (1) to (4) | 10-15 Vdc | Voltage Input |
| (2) to (4) | 10 Vdc | Pulsing Signal |
| (3) to (4) | 10 Vdc | Pulsing Signal |

9-4. PUMP MOTOR ASSEMBLY

| | | | | | | | | | | |
|-------------------------------|--|--|--------|------------|---------|--|-------------|--------|------------|---------|
| <p>Circuit diagram</p> | <div style="display: flex; justify-content: space-around;"> <div style="border: 1px solid black; padding: 5px; background-color: #e0e0e0; width: 45%;"> <p style="text-align: center;">Circuit in the MAIN PWB</p> </div> <div style="border: 1px solid black; padding: 5px; background-color: #e0e0e0; width: 45%;"> <p style="text-align: center;">Circuit diagram</p> </div> </div> <p style="text-align: center;">* Each circuits of loads in wiring diagram are all same.</p> | | | | | | | | | |
| <p>Object</p> | | | | | | | | | | |
| <p>Function</p> | <p>Two pump motors are used to drain the tub and to circulate the water / detergent solution.</p> | | | | | | | | | |
| <p>Test points</p> | <p style="text-align: center;">Drain Pump</p> | <p style="text-align: center;">Circulation Pump</p> | | | | | | | | |
| <p>Result</p> | <p style="text-align: center;">Drain Pump</p> <table border="1" style="width: 100%; border-collapse: collapse;"> <tr> <td style="width: 50%;">Test Points</td> <td style="width: 50%;">Result</td> </tr> <tr> <td>(1) to (2)</td> <td>10-20 Ω</td> </tr> </table> | Test Points | Result | (1) to (2) | 10-20 Ω | <p style="text-align: center;">Circulation Pump</p> <table border="1" style="width: 100%; border-collapse: collapse;"> <tr> <td style="width: 50%;">Test Points</td> <td style="width: 50%;">Result</td> </tr> <tr> <td>(1) to (2)</td> <td>18-30 Ω</td> </tr> </table> | Test Points | Result | (1) to (2) | 18-30 Ω |
| Test Points | Result | | | | | | | | | |
| (1) to (2) | 10-20 Ω | | | | | | | | | |
| Test Points | Result | | | | | | | | | |
| (1) to (2) | 18-30 Ω | | | | | | | | | |

9-5. INLET VALVE ASSEMBLY

Circuit diagram

Circuit in the MAIN PWB

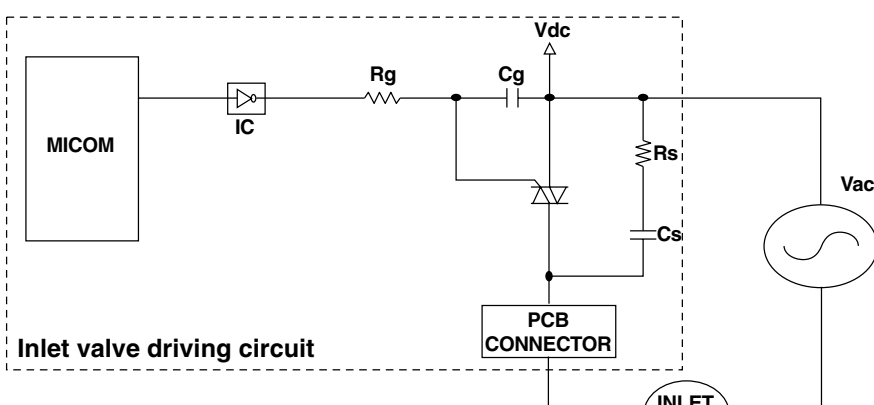

Circuit diagram

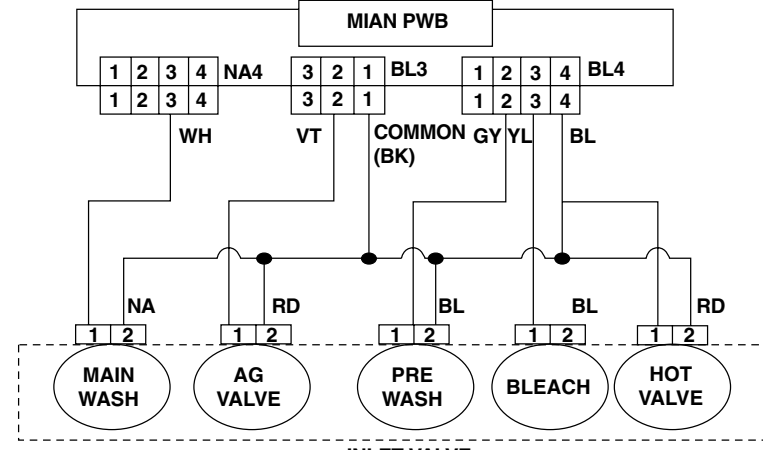

* Each circuits of loads in wiring diagram are all same.

Function

Depending on the cycle and water temperature, the controller will energize the hot or cold water valve solenoids to meet the selected water temperature.

Test points and Result

After pull out the connector of defective valve, check the resistance.

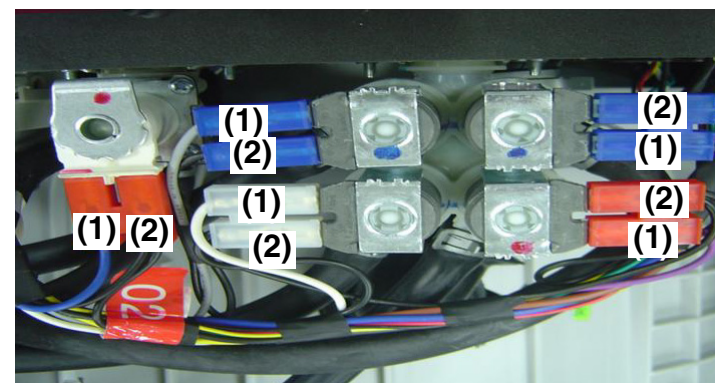



| | |
|-------------|------------|
| Test points | (1)-(2) |
| Result | 0.8-1.2 kΩ |

44

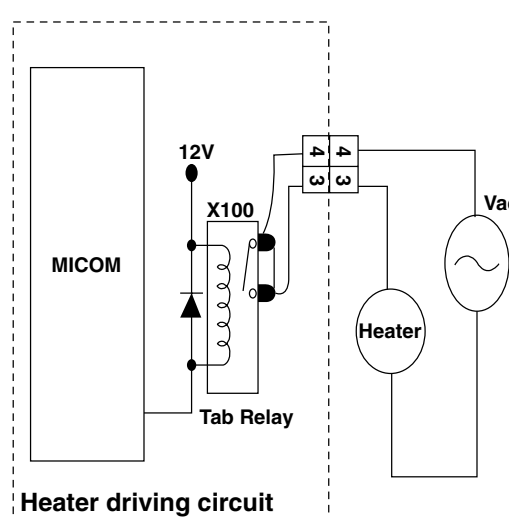
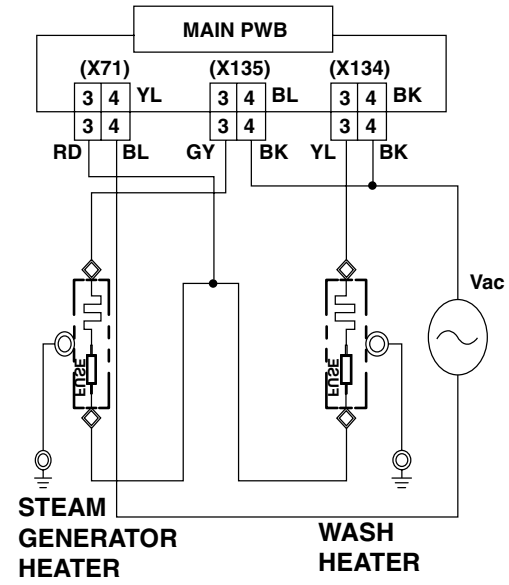
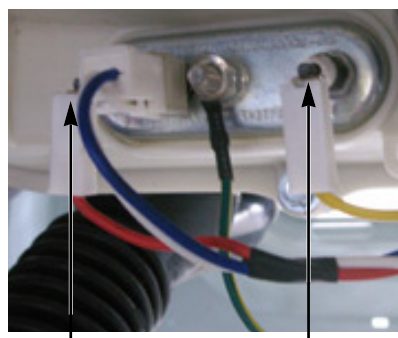
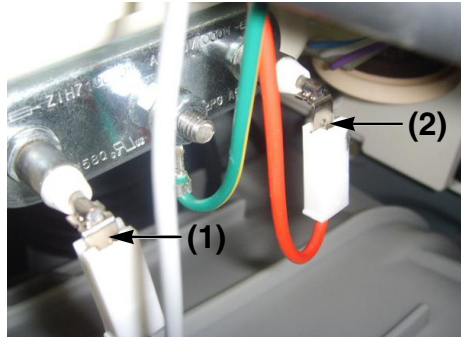
9-6. HEATER ASSEMBLY

| <p>Circuit diagram</p> | <p style="text-align: center;">Circuit in the MAIN PWB</p>  <p style="text-align: center;">Heater driving circuit</p> | <p style="text-align: center;">Circuit diagram</p>  <p style="text-align: center;">* Each circuits of loads in wiring diagram are all same.</p> | | | | | | | | | | | | |
|-------------------------------|---|--|-------------|--|------------------------|--|-------------|--------|-------------|--------|------------|---------|------------|---------|
| <p>Function</p> | <p>1. The Wash Heater is designed to raise the wash water to the desired temperature selection during certain wash cycles.</p> | | | | | | | | | | | | | |
| <p>Test points</p> |  <p style="text-align: center;">(1) (2)</p> <p style="text-align: center;">Wash Heater</p> |  <p style="text-align: center;">(1) (2)</p> <p style="text-align: center;">Steam Generator Heater</p> | | | | | | | | | | | | |
| <p>Result</p> | <table border="1" style="width: 100%; border-collapse: collapse;"> <thead> <tr> <th colspan="2" style="text-align: center;">Wash Heater</th> <th colspan="2" style="text-align: center;">Steam Generator Heater</th> </tr> <tr> <th style="width: 25%;">Test Points</th> <th style="width: 25%;">Result</th> <th style="width: 25%;">Test Points</th> <th style="width: 25%;">Result</th> </tr> </thead> <tbody> <tr> <td style="text-align: center;">(1) to (2)</td> <td style="text-align: center;">12-18 Ω</td> <td style="text-align: center;">(1) to (2)</td> <td style="text-align: center;">12-18 Ω</td> </tr> </tbody> </table> | | Wash Heater | | Steam Generator Heater | | Test Points | Result | Test Points | Result | (1) to (2) | 12-18 Ω | (1) to (2) | 12-18 Ω |
| Wash Heater | | Steam Generator Heater | | | | | | | | | | | | |
| Test Points | Result | Test Points | Result | | | | | | | | | | | |
| (1) to (2) | 12-18 Ω | (1) to (2) | 12-18 Ω | | | | | | | | | | | |

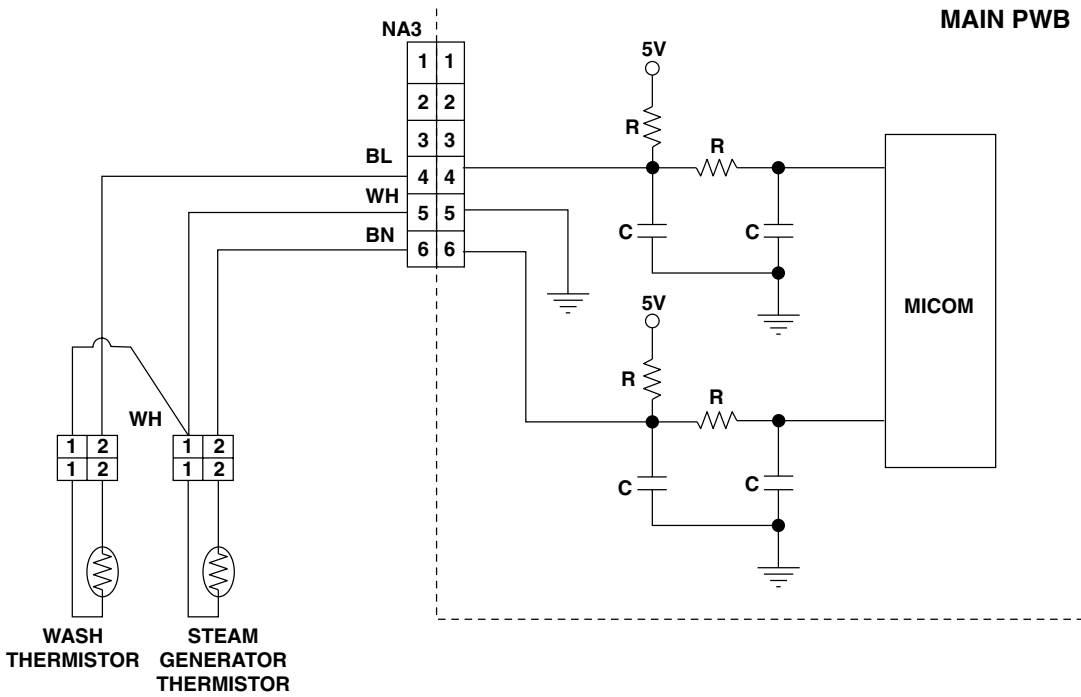
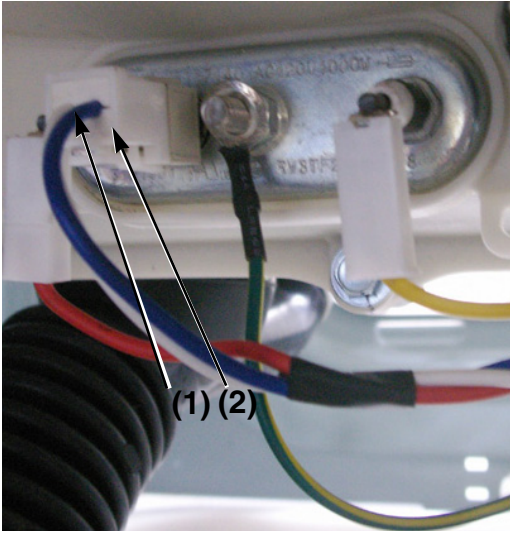
9-7. THERMISTOR ASSEMBLY

| | |
|-------------------------------|--|
| <p>Circuit diagram</p> | <p style="text-align: center;">Circuit in the MAIN PWB / Circuit diagram</p>  <p>The diagram illustrates the electrical circuit for the thermistors. On the left, two thermistors are shown: the WASH THERMISTOR and the STEAM GENERATOR THERMISTOR. Each has two pins labeled 1 and 2. The WASH THERMISTOR is connected to the WH pin (pin 4) of the NA3 connector. The STEAM GENERATOR THERMISTOR is connected to the WH pin (pin 4) of the NA3 connector. The NA3 connector has pins 1, 2, 3, 4, 5, and 6. The circuit includes a 5V supply, resistors (R), capacitors (C), and a MICOM component. The circuit is shown within a dashed box labeled MAIN PWB.</p> |
| <p>Function</p> | <p>The thermistor (temperature sensor) is used to monitor water temperature in the tub.</p> |
| <p>Test points</p> | <div style="display: flex; justify-content: space-around;"> <div style="text-align: center;">  <p>Wash Thermistor</p> </div> <div style="text-align: center;">  <p>Steam generator Thermistor</p> </div> </div> |

| | | | |
|---------------|------------------------|--|------------------|
| Result | Wash Thermistor | | |
| | Test Points | Result (tolerance $\pm 5\%$) | Remarks |
| | (1) to (2) | 39.5 k Ω | At 86°F (30°C) |
| | | 26.1 k Ω | At 104°F (40°C) |
| | | 12.1 k Ω | At 140°F (60°C) |
| | | 8.5 k Ω | At 158°F (70°C) |
| | | 3.8 k Ω | At 203°F (95°C) |
| | | 2.8 k Ω | At 221°F (105°C) |

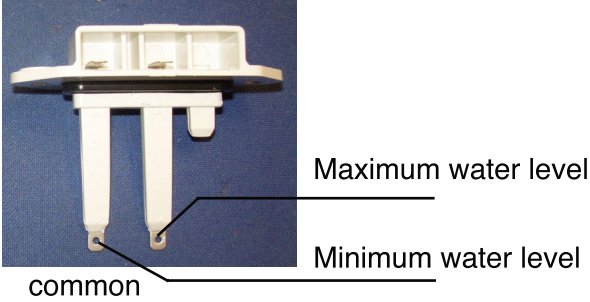
| | |
|------------------------|---|
| <p>Function</p> | <p>2) Operation mechanism of Steam generator After supplying some amount of water through inlet valve and water level sensor, Heater operates and steam generates. Generated steam is sprayed by nozzle. If the water in the steam generator is reduced by spraying steam, water level sensor decide to supply water or not.</p> <p>3) Operation method of Steam generator The Steam Generator Assembly is supplied as an assembly only; parts like the water level sensor, thermistor, or heater cannot be replaced individually. Diagnosis is limited to determining malfunction and replacing as an assembly. The steam generator does not have to be removed from the machine to be drained. Be sure to let the water cool to avoid a burn. Have a hose available to slip onto the connector or a large towel to catch the water so it doesn't run down into the machine cabinet. If you remove the steam generator before draining it, be sure to avoid tipping it and spilling the water.</p> |
| | <p>2. Water level sensor</p> <p>1) Structure of water level sensor</p>  <p>2) Function of Water level sensor It determines the water level in the steam generator and keeps it full protect the heating element.</p> |

10. DISASSEMBLY INSTRUCTIONS

* Be sure to unplug the machine before disassembling and repairing the parts.

CONTROL PANEL ASSEMBLY

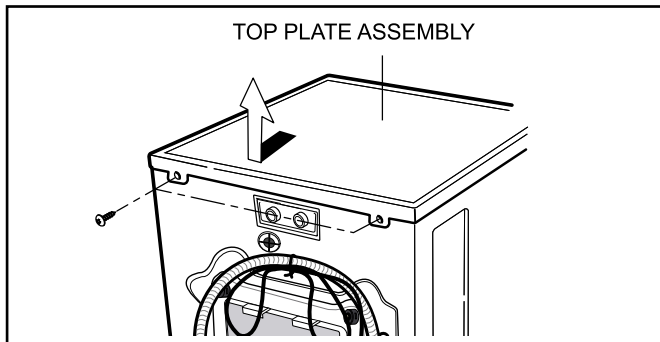

- ① Unscrew 2 screws on the back of the top plate.
- ② Pull the top plate backward and upward as shown.

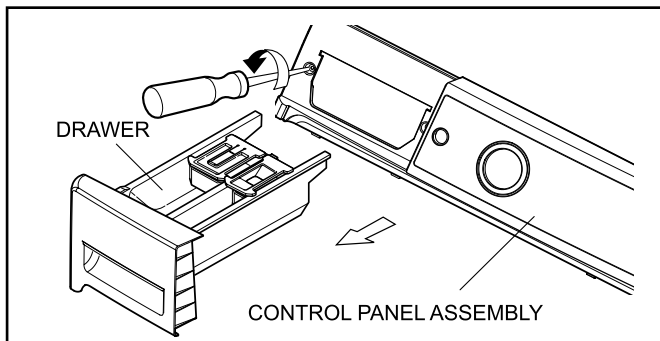

- ③ Disconnect the Display PWB assembly connector from trans cable.
- ④ Pull out the drawer and unscrew 2 screws.

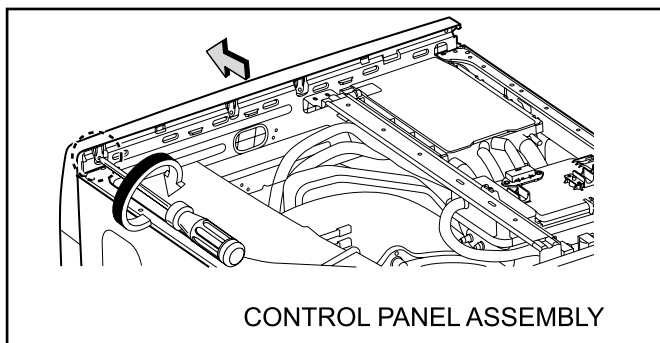

- ⑤ Remove one screw.
- ⑥ Lift the side the control panel assembly and pull it out

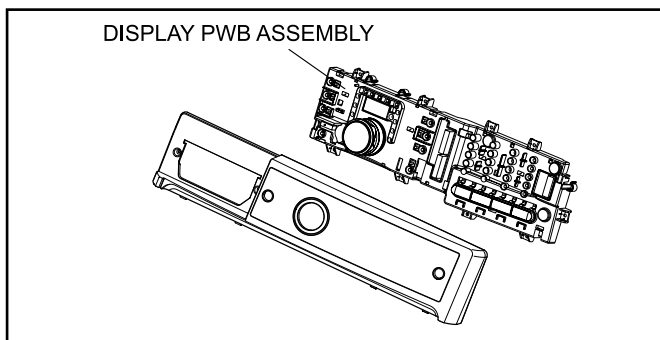

- ⑦ Unscrew the 9 screws(M4), 1 screw(M3) from the control panel assembly.
- ⑧ Disassemble the Display PWB Assembly.

MAIN PWB ASSEMBLY

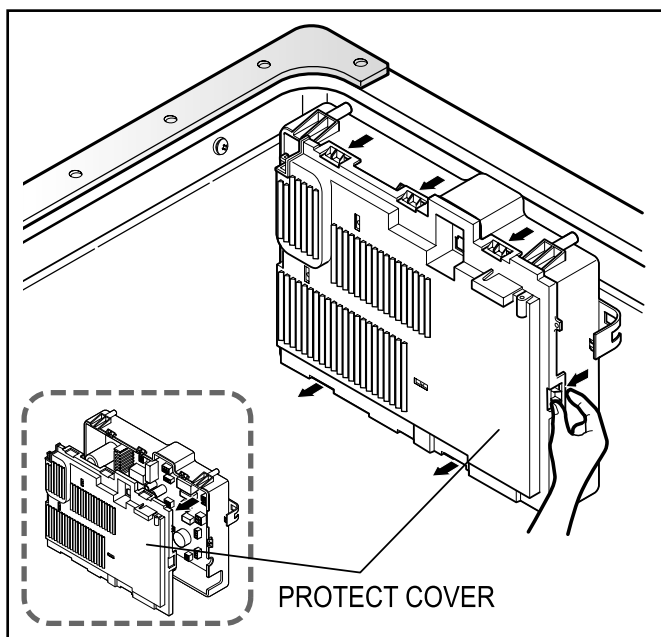

- ① Disconnect the POWER connector and SENSOR SWITCH ASSEMBLY.
- ② Remove the Protective cover.

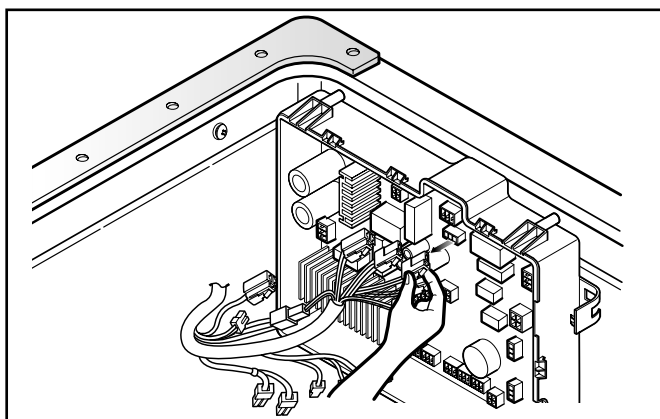

- ③ Disconnect the connectors.

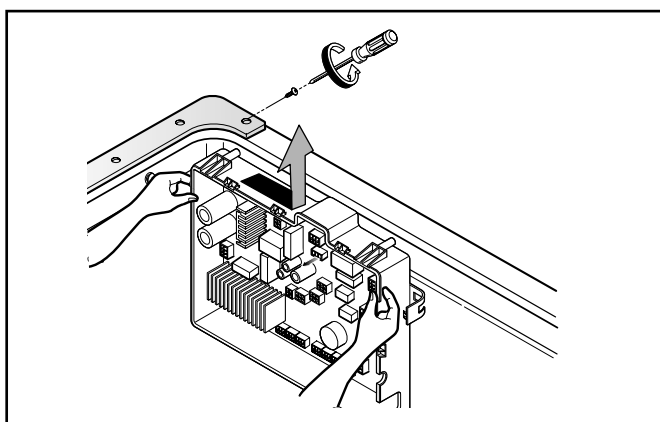

- ④ Unscrew 1 screw on the back.
- ⑤ Remove the Main PWB.

DISPENSER ASSEMBLY

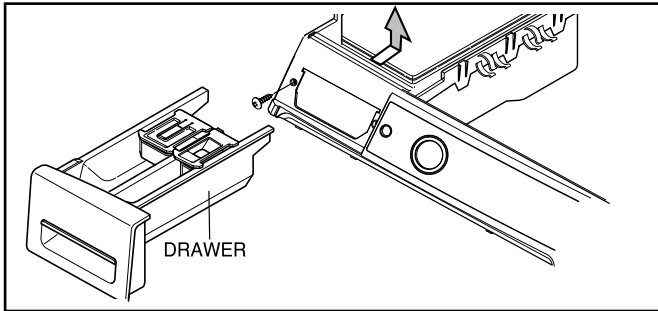

- ① Disassemble the top plate assembly.
- ② Pull out the drawer.
- ③ Push out the DISPENSER ASSEMBLY after unscrewing 2 screws.

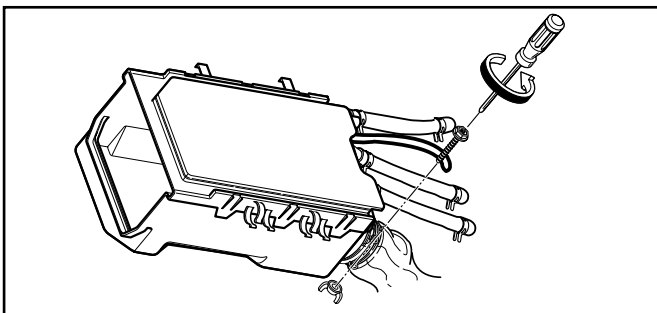

- ④ Unscrew the Clamp nut at the lower part of the dispenser.

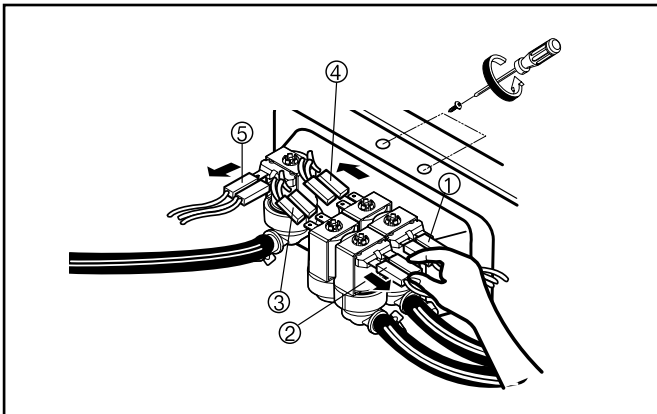

- ⑤ Disassemble the 4 connectors from the valves.

※ Wire Color

- ① Blue Housing (YL-BK)
- ② White Housing (BK-WH)
- ③ Blue Housing (BK-GY)
- ④ Red Housing (BK-Blue)

- ⑥ Unscrew 2 screws from the back of the cabinet.

NOISE FILTER

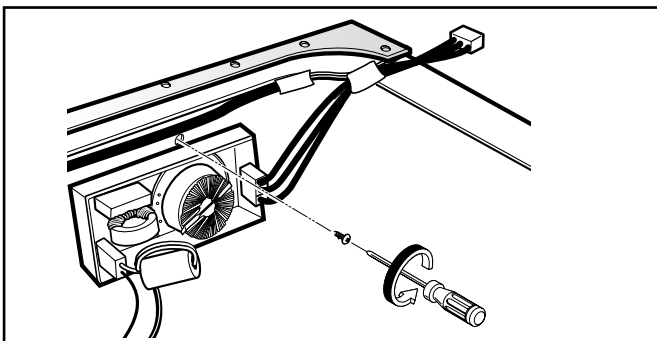

- ① Disassemble two (or three) connectors from the NOISE FILTER.
- ② Unscrew a screw from the TOP BRACKET.

CABINET COVER

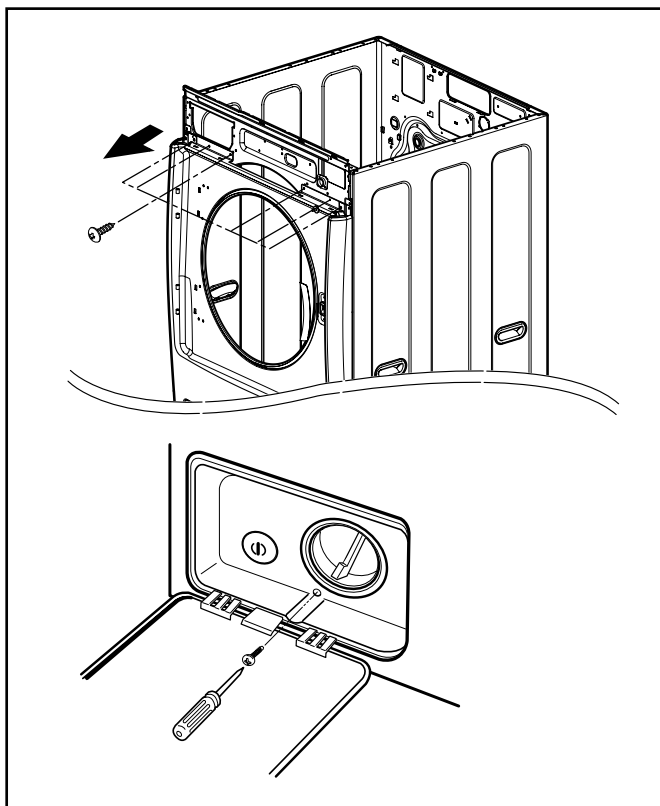

- ① Unscrew the 6 screws from upper of the cabinet cover.
- ② Unscrew the screw from filter cover.

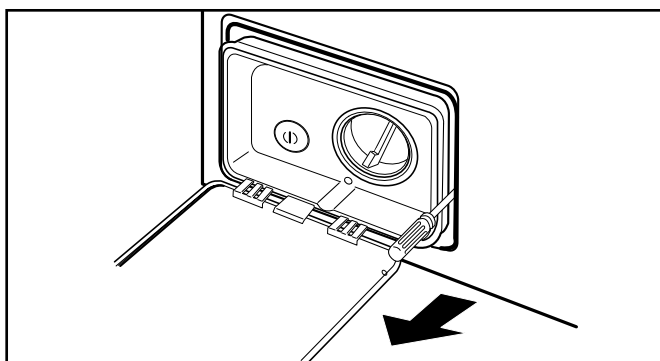

- ③ Put a flat (-) screwdriver or putty knife into the hinge slots at the bottom of the cover and pry it out.

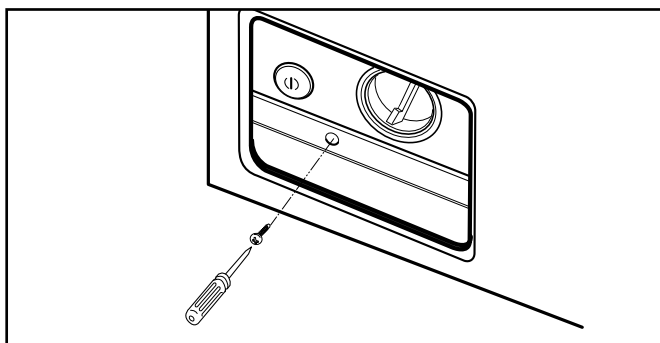

- ④ Unscrew the screw from the lower side of the cabinet cover.

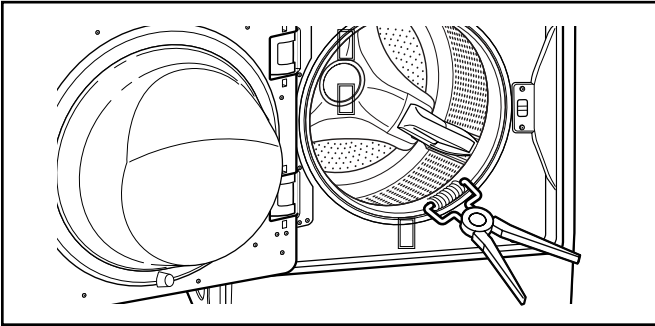

- ⑤ Open the door.
- ⑥ Disassemble the clamp assembly.

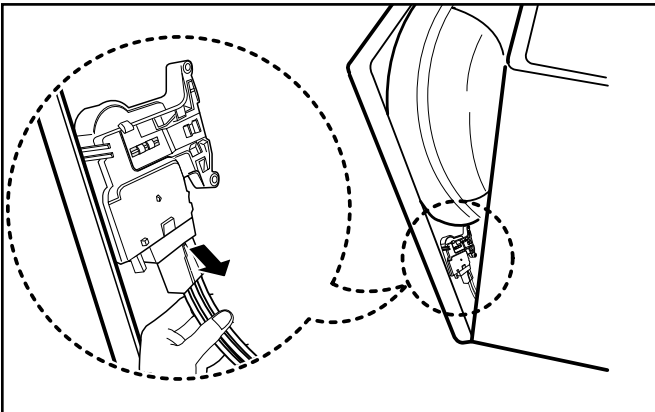

- ⑦ Tilt the cabinet cover.
- ⑧ Disconnect the door switch connector.

※ **NOTE:** When assembling the CABINET COVER, connect the door switch connector.

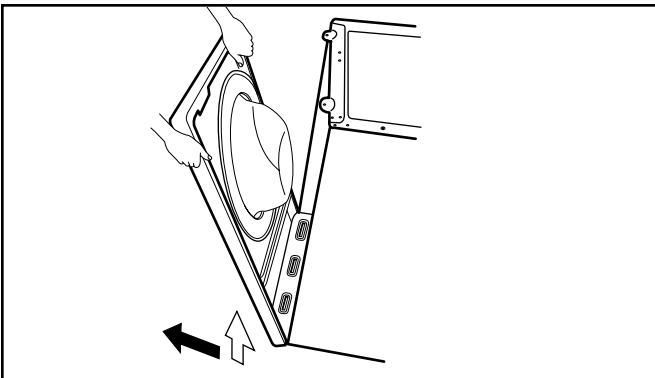

- ⑨ Lift and separate the cabinet cover.

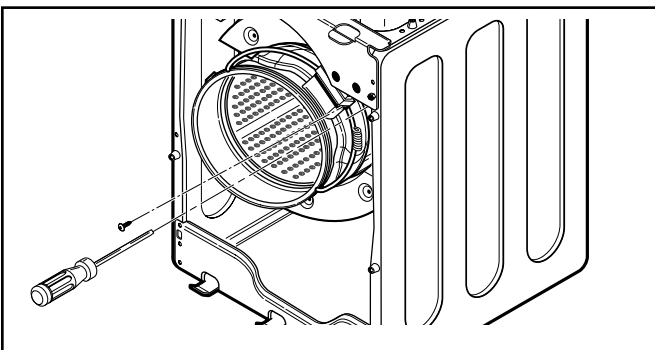

- ⑩ Disassemble the clamp assembly.
- ⑪ Disassemble the gasket.

DOOR

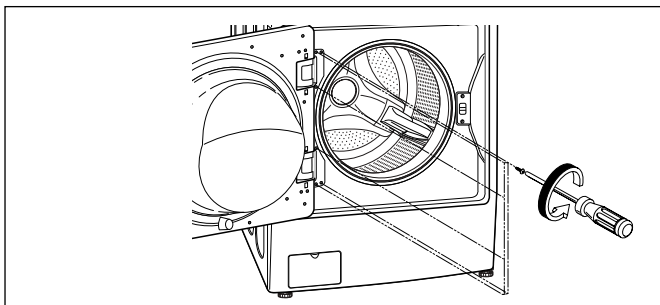

Open the door.

Unscrew the 6 screws from the HINGE COVER.

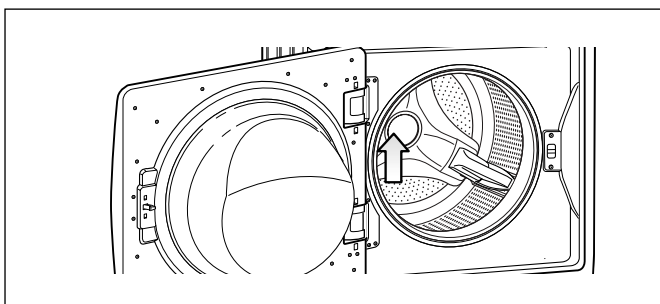

Put a flat (-) screwdriver into the opening of the hinge, and pull out the hinge cover.

DOOR LOCK SWITCH ASSEMBLY

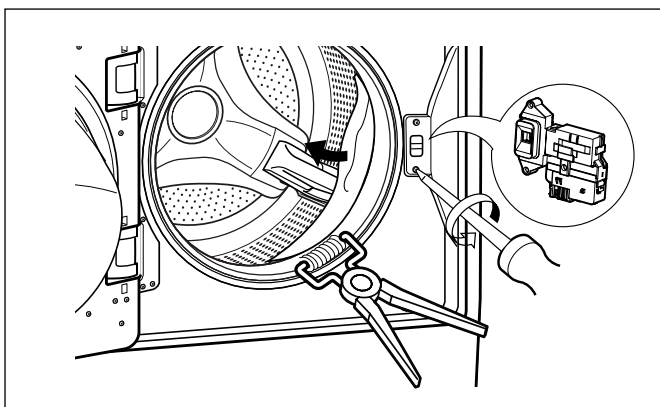

Open the door and disassemble the CLAMP ASSEMBLY.

Unscrew the 2 screws.

NOTE

¥Reconnect the connector after replacing the DOOR SWITCH ASSEMBLY.

PUMP

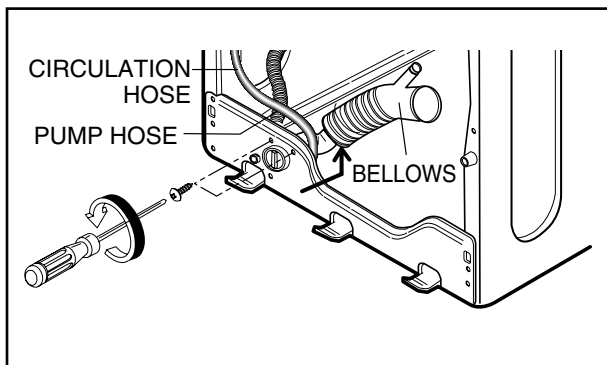

- ① Disassemble the cabinet cover.
- ② Separate the pump hose, the bellows and the circulation hose assembly from the pump assembly.
- ③ Disassemble the pump assembly in arrow direction.

HEATER

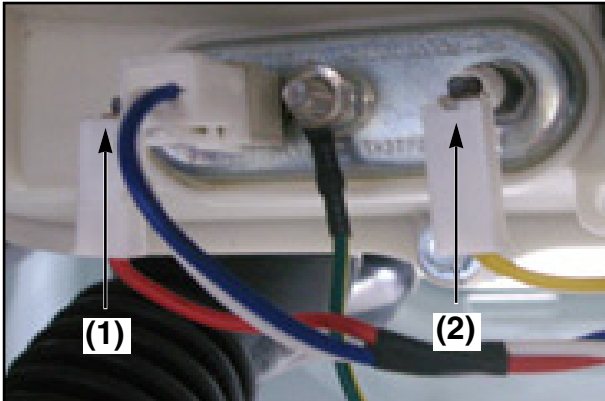

- ① Disassemble the cabinet cover.
- ② Separate 2 connectors from the heater.
- ③ Loosen the nut and pull out the heater.

※ CAUTION

- When assembling the heater, insert the heater into the heater clip on the bottom of the tub.
- Tighten the fastening nut so the heater is secure.

THERMISTOR

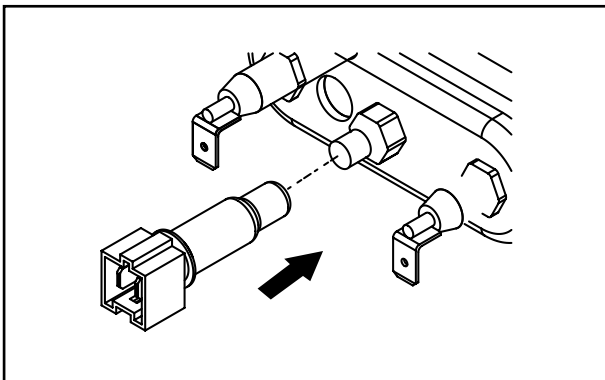

- ① Disassemble the cabinet cover.
- ② Unplug the white connector from the thermistor.
- ③ Pull it out by holding the bracket of the thermistor.

WHEN FOREIGN OBJECT IS STUCK BETWEEN DRUM AND TUB

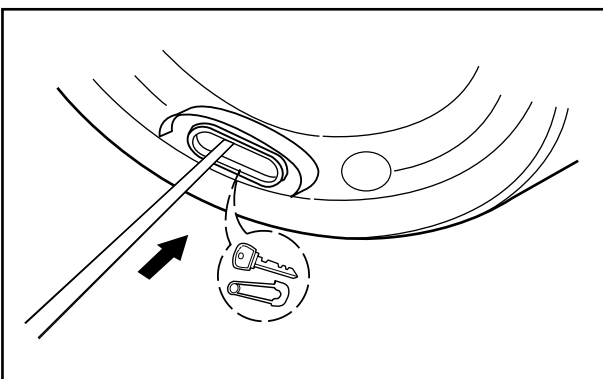

- ① Disassemble the cabinet cover.
- ② Separate the heater from the tub.
- ③ Remove any foreign objects (wire, coin, etc.) by inserting a long bar in the opening.

MOTOR/DAMPER

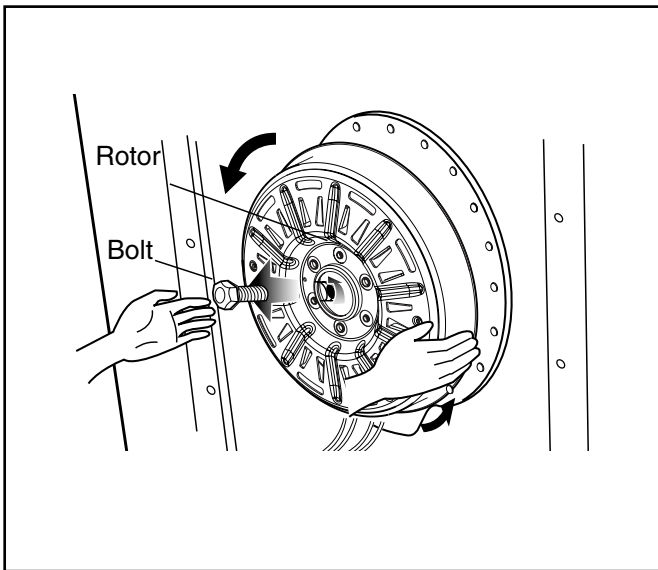

- ① Disassemble the back cover.
- ② Remove the bolt.
- ③ Pull out the Rotor.

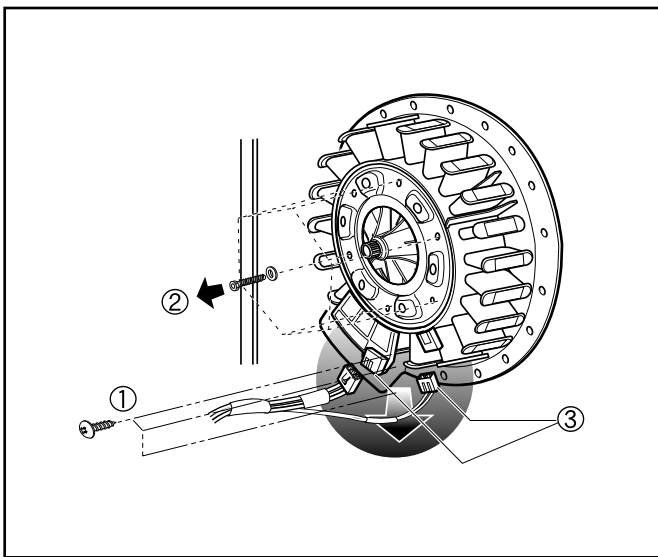

- ① Unscrew the 2 screws from the tub bracket.
- ② Remove the 6 bolts on the stator.
- ③ Unplug the 2 connectors from the stator.

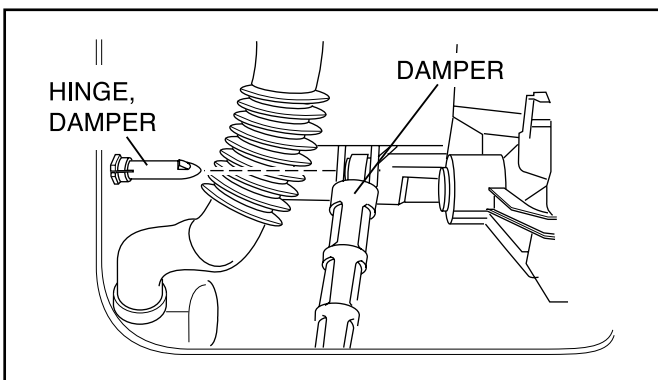

- ① Disassemble the damper hinges from the tub and base.

※ NOTE

If you pull the dampers apart, they must be replaced. If you do not separate them, they can be re-used.

11. EXPLODED VIEW

11-1. CABINET & CONTROL PANEL ASSEMBLY

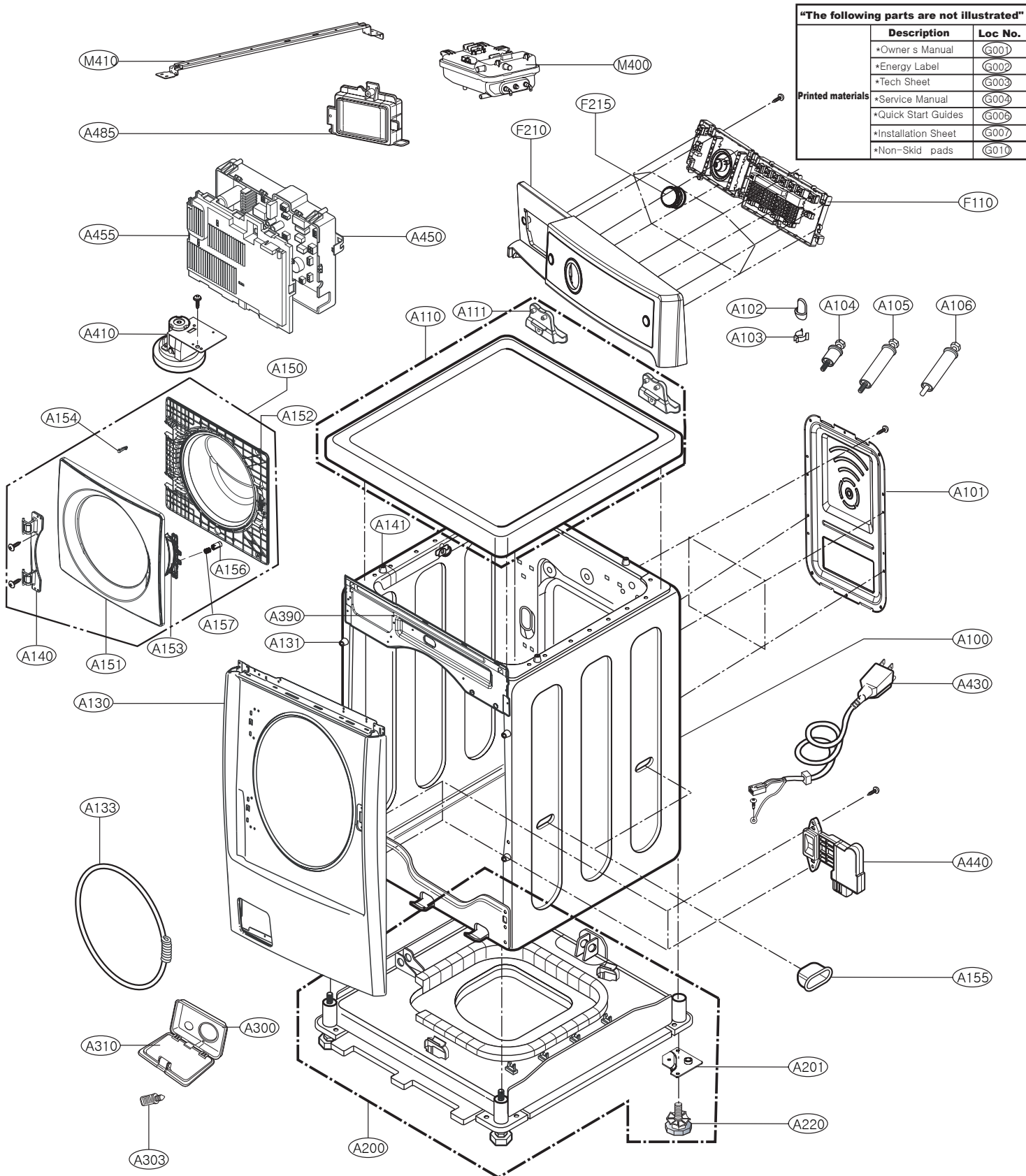

11-2. DRUM AND TUB ASSEMBLY

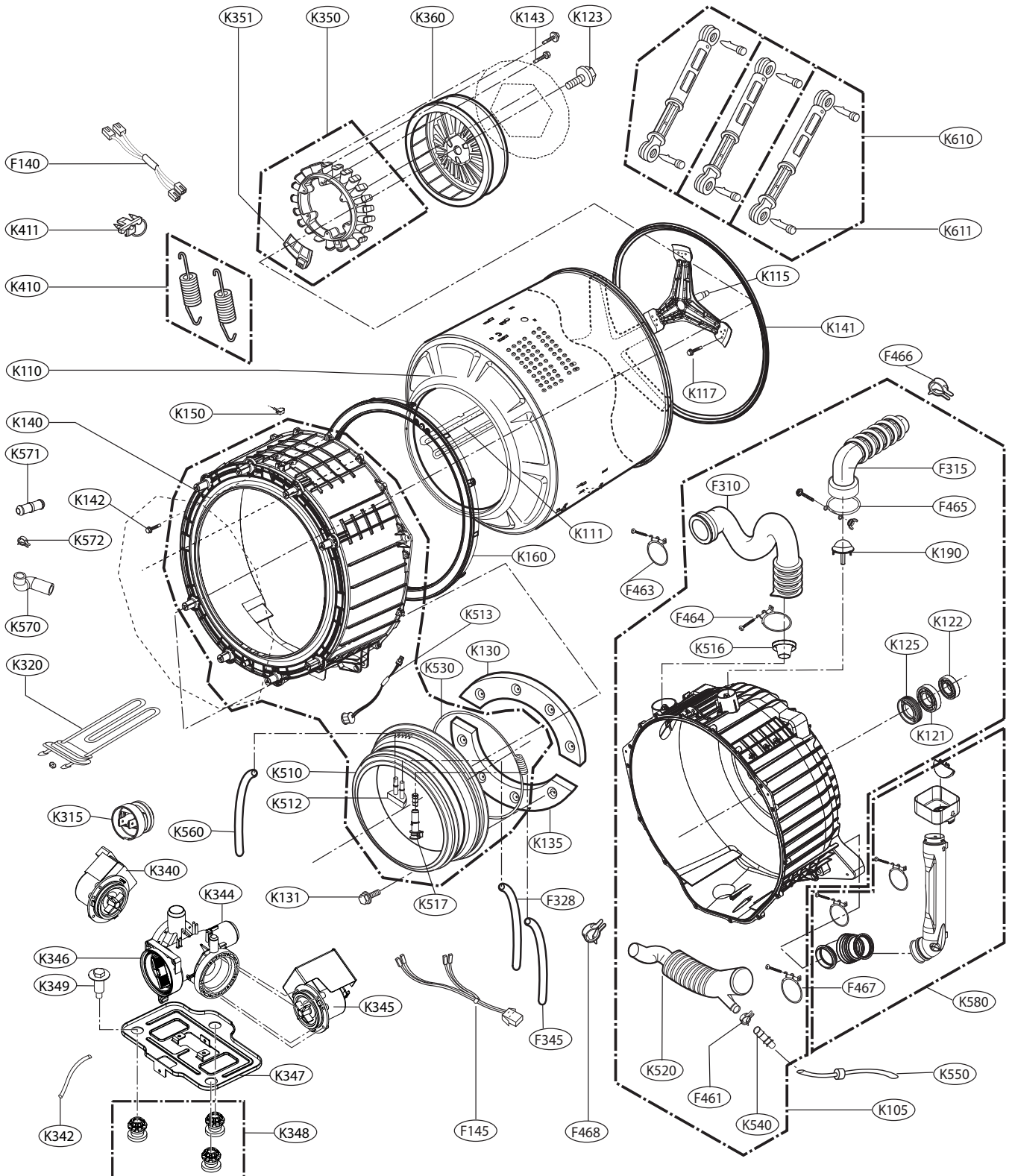

※ In case of replacing THERMISTOR of HEATER ASSEMBLY(K320), replace HEATER ASSEMBLY(K320), HEATER ASSEMBLY(K320) includes THERMISTOR.

※ In case of replacing BEARING,BALL(K121,K122) and GASKET(K125), replace TUB ASSEMBLY,OUTER(K105), TUB ASSEMBLY,OUTER(K105) includes BEARING,BALL(K121,K122) and GASKET(K125).

※ Part Assembly(K142) includes 10 screws.

11-3. DISPENSER ASSEMBLY

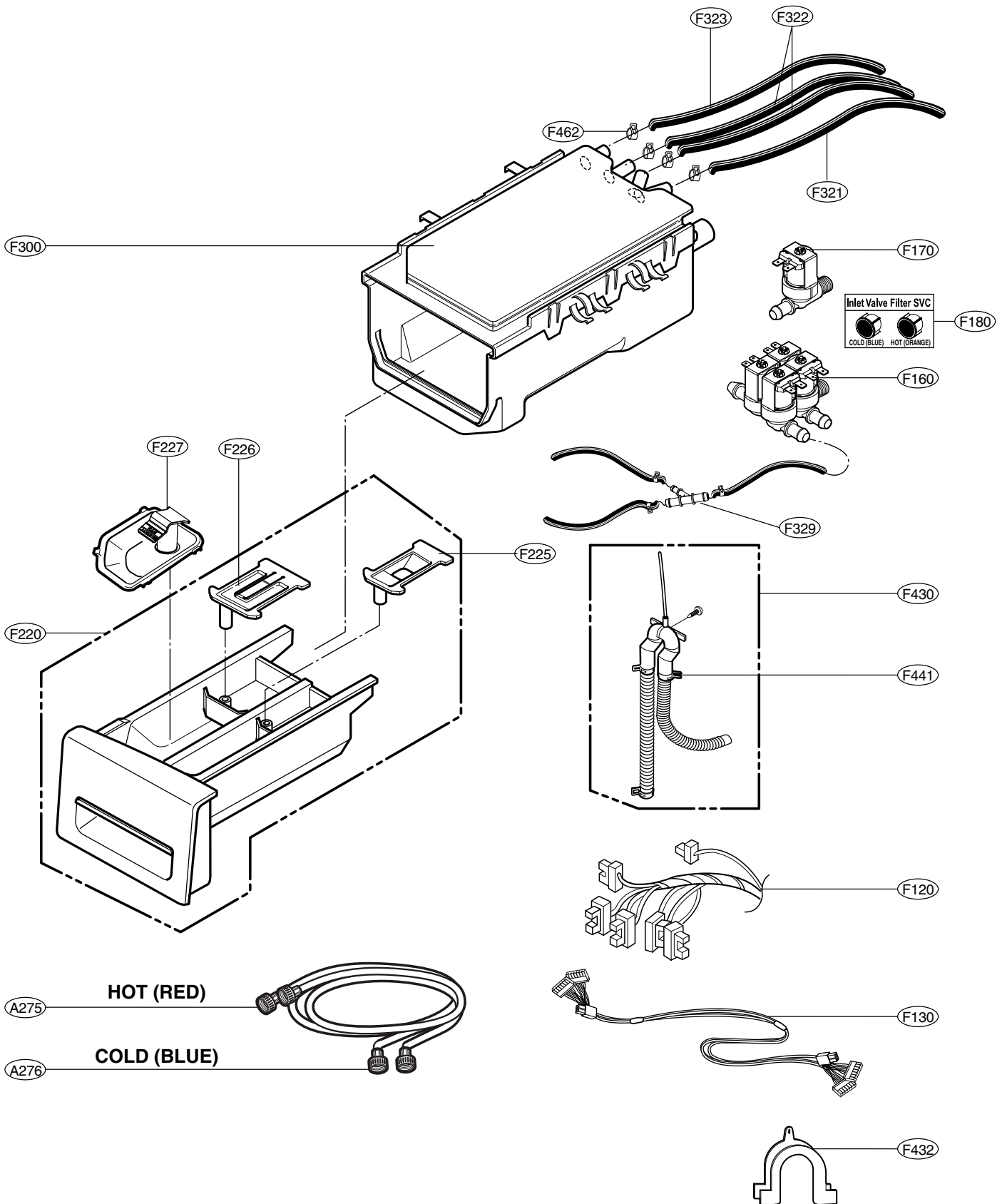



P/No.: MFL30599176