

This Owner's Manual is provided and hosted by [Appliance Factory Parts](#).

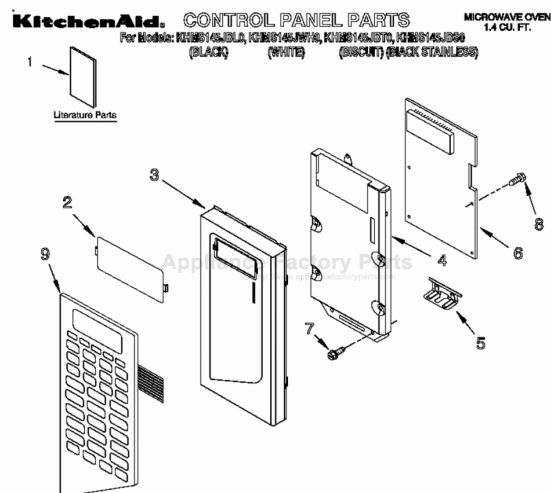

# KITCHENAID KHMS145JBL-0 Owner's Manual

[Shop genuine replacement parts for KITCHENAID  
KHMS145JBL-0](#)



[Find Your KITCHENAID Microwave Parts - Select From 105 Models](#)

----- Manual continues below -----

# USE & CARE GUIDE

## KitchenAid® Microwave Hood Combination

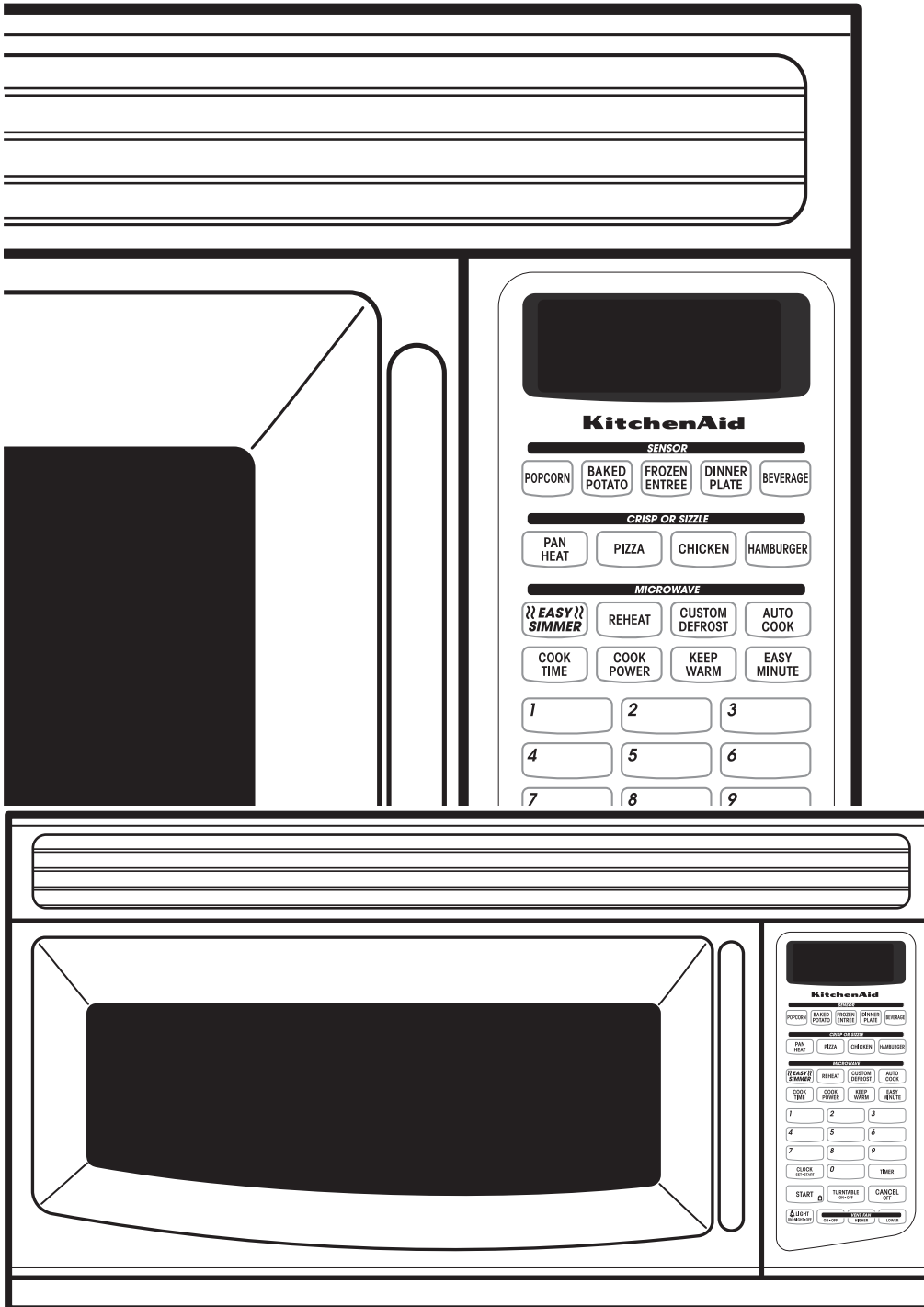

A Note to You .....2

Microwave Oven Safety.....3

Removing and Replacing  
the Microwave Oven .....6

Getting to Know Your  
Microwave Oven.....7

    Operating tips .....7

    Electrical connection.....7

    Microwave oven features.....8

    Control panel features .....9

    Using the child lock.....11

    Using the demo/  
    learning feature .....11

    Using the vent fan .....12

    Using the cooktop/  
    countertop light .....12

    Setting the clock .....13

    Using the timer .....14

**Using Your Microwave Oven ..15**

    Cooking at high cook power ...15

    Cooking at different  
    cook powers .....16

    Cooking in stages .....18

    Using AUTO COOK .....20

    Using EASY SIMMER .....21

    Using REHEAT .....22

    Using CUSTOM DEFROST ...23

    Using KEEP WARM.....26

    Sensor cooking .....27

    Using CRISP OR SIZZLE .....28

    Using EASY MINUTE .....29

    Changing preset cooking times ..29

    Using aluminum foil .....30

    Cooking you should not do  
    in your microwave oven .....30

    Using 2-4 Plates .....30

    Using the cooking rack .....30

**Caring for Your  
Microwave Oven.....31**

    Installing and caring for filters ..31

    Replacing the cooktop  
    and oven lights .....32

**Questions and Answers .....33**

**Troubleshooting .....34**

    Requesting Assistance  
    or Service.....36

    Warranty.....40

**1•800•422•1230**

Call our Customer Interaction  
Center with questions  
or comments.

# A NOTE TO YOU

## Thank you for buying a KITCHENAID® appliance!

KitchenAid designs the best tools for the most important room in your house. To ensure that you enjoy many years of trouble-free operation, we developed this Use and Care Guide. It contains valuable information concerning how to operate and maintain your new appliance properly. Please read it carefully.

Also, please complete and mail the enclosed Product Registration Card.

## For assistance or service

Call the Customer Interaction Center toll free .....**1-800-422-1230**

If you need assistance or service, first see the “Troubleshooting” section of this book. After checking “Troubleshooting,” additional help can be found by checking the “Requesting Assistance or Service” section, or by calling the telephone number above.

When calling, you will need to know your appliance’s complete model number and serial number. You can find this information on the model and serial number label/plate (see diagram in the “Getting to Know Your Microwave Oven” section.)

Keep this book and the sales slip together in a safe place for future reference. **You must provide proof of purchase or installation date for in-warranty service.**

<b>Model Number</b> _____	<b>Builder/Dealer Name</b> _____
<b>Serial Number</b> _____	<b>Address</b> _____
<b>Date Installed</b> _____	<b>Phone</b> _____

# MICROWAVE OVEN SAFETY

## Your safety and the safety of others are very important.

We have provided many important safety messages in this manual and on your appliance. Always read and obey all safety messages.



This is the safety alert symbol.

This symbol alerts you to potential hazards that can kill or hurt you and others.

All safety messages will follow the safety alert symbol and either the word "DANGER" or "WARNING." These words mean:

**⚠ DANGER**

**You can be killed or seriously injured if you don't immediately follow instructions.**

**⚠ WARNING**

**You can be killed or seriously injured if you don't follow instructions.**

All safety messages will tell you what the potential hazard is, tell you how to reduce the chance of injury, and tell you what can happen if the instructions are not followed.

## IMPORTANT SAFETY INSTRUCTIONS

When using electrical appliances basic safety precautions should be followed, including the following:

**WARNING:** To reduce the risk of burns, electric shock, fire, injury to persons, or exposure to excessive microwave energy:

- Read all instructions before using the microwave oven.
- Read and follow the specific "PRECAUTIONS TO AVOID POSSIBLE EXPOSURE TO EXCESSIVE MICROWAVE ENERGY" found in this section.
- The microwave oven must be grounded. Connect only to properly grounded outlet. See "GROUNDING INSTRUCTIONS" found in this section and in the provided Installation Instructions.
- Install or locate the microwave oven only in accordance with the provided Installation Instructions.
- Some products such as whole eggs in the shell and sealed containers – for example, closed glass jars – may explode and should not be heated in the microwave oven.
- Use the microwave oven only for its intended use as described in this manual. Do not use corrosive chemicals or vapors in the microwave oven. This type of oven is specifically designed to heat, cook, or dry food. It is not designed for industrial or laboratory use.
- As with any appliance, close supervision is necessary when used by children.
- Do not operate the microwave oven if it has a damaged cord or plug, if it is not working properly, or if it has been damaged or dropped.
- The microwave oven should be serviced only by qualified service personnel. Call an authorized service company for examination, repair, or adjustment.
- See door surface cleaning instructions in the "Caring for Your Microwave Oven" section.
- To reduce the risk of fire in the oven cavity:
  - Do not overcook food. Carefully attend the microwave oven if paper, plastic, or other combustible materials are placed inside the oven to facilitate cooking.
  - Remove wire twist-ties from paper or plastic bags before placing bags in oven.
  - If materials inside the oven should ignite, keep oven door closed, turn oven off, and disconnect the power cord, or shut off power at the fuse or circuit breaker panel.
  - Do not use the cavity for storage purposes. Do not leave paper products, cooking utensils, or food in the cavity when not in use.

**SAVE THESE INSTRUCTIONS**

continued on next page

# MICROWAVE OVEN SAFETY

## IMPORTANT SAFETY INSTRUCTIONS

- Suitable for use above both gas and electric cooking equipment.
- Intended to be used above ranges with maximum width of 36 inches.
- Clean Ventilating Hoods Frequently - Grease should not be allowed to accumulate on hood or filter.
- Oversized foods or oversized metal utensils should not be inserted in the microwave oven as they may create a fire or risk of electric shock.
- Do not clean with metal scouring pads. Pieces can burn off the pad and touch electrical parts involving a risk of electric shock.
- Do not use paper products when appliance is operated in the "PAN BROWN" mode.
- Do not store any materials, other than manufacturer's recommended accessories, in this oven when not in use.
- Do not store anything directly on top of the microwave oven when the microwave oven is in operation.
- When flaming foods under the hood, turn the fan on.
- Use care when cleaning the vent-hood filter. Corrosive cleaning agents, such as lye-based oven cleaners, may damage the filter.
- Do not cover or block any openings on the microwave oven.
- Do not store this microwave oven outdoors. Do not use the microwave oven near water - for example, near a kitchen sink, in a wet basement, or near a swimming pool, and the like.
- Do not immerse cord or plug in water.
- Keep cord away from heated surfaces.
- Do not let cord hang over edge of table or counter.
- Do not mount over a sink.
- Do not cover racks or any other part of the oven with metal foil. This will cause overheating of the oven.

## SAVE THESE INSTRUCTIONS

## PRECAUTIONS TO AVOID POSSIBLE EXPOSURE TO EXCESSIVE MICROWAVE ENERGY

- (a) Do not attempt to operate this oven with the door open since open-door operation can result in harmful exposure to microwave energy. It is important not to defeat or tamper with the safety interlocks.
- (b) Do not place any object between the oven front face and the door or allow soil or cleaner residue to accumulate on sealing surfaces.
- (c) Do not operate the oven if it is damaged. It is particularly important that the oven door close properly and that there is no damage to the:
  - (1) Door (bent),
  - (2) Hinges and latches (broken or loosened),
  - (3) Door seals and sealing surfaces.
- (d) The oven should not be adjusted or repaired by anyone except properly qualified service personnel.

# MICROWAVE OVEN SAFETY

## Electrical requirements

Observe all governing codes and ordinances. A 120-Volt, 60-Hz, AC-only, 15- or 20-amp fused electrical supply is required. (A time-delay fuse is recommended.) It is recommended that a separate circuit serving only this appliance be provided.

### **⚠ WARNING**



#### **Electrical Shock Hazard**

**Plug into a grounded 3 prong outlet.**

**Do not remove ground prong.**

**Do not use an adapter.**

**Do not use an extension cord.**

**Failure to follow these instructions can result in death, fire, or electrical shock.**

## GROUNDING INSTRUCTIONS

### • **For all cord connected appliances:**

The microwave oven must be grounded. In the event of an electrical short circuit, grounding reduces the risk of electric shock by providing an escape wire for the electric current. The microwave oven is equipped with a cord having a grounding wire with a grounding plug. The plug must be plugged into an outlet that is properly installed and grounded.

**WARNING:** Improper use of the grounding plug can result in a risk of electric shock. Consult a qualified electrician or serviceman if the grounding instructions are not completely understood, or if doubt exists as to whether the microwave oven is properly grounded.

Do not use an extension cord. If the power supply cord is too short, have a qualified electrician or serviceman install an outlet near the microwave oven.

# REMOVING AND REPLACING THE MICROWAVE OVEN

## ⚠ WARNING

### Excessive Weight Hazard

Use two or more people to move and install microwave oven.

Failure to do so can result in back or other injury.

If you need to remove your Microwave Hood Combination for any reason, follow these simple steps:

### To remove:

1. Unplug microwave oven or disconnect power.
2. Remove filters and vent grille.

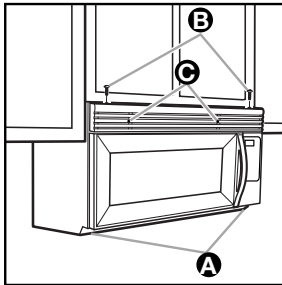

- If filters **A** are installed, push in at the tab and slide filter to the outside edge to remove.
- Remove the two screws **B** from the top of the microwave oven cabinet (the screws located closest to the front corners). Do not remove the screws located towards the center of the cabinet.

- Remove the vent grille **C**. Set the screws and grille aside. (If grille cannot be removed, see step 4.)

3. After removing all oven contents, including the turntable and support, tape the door in the closed position. Then remove the two bolts **D** securing the microwave oven to the upper cabinet.

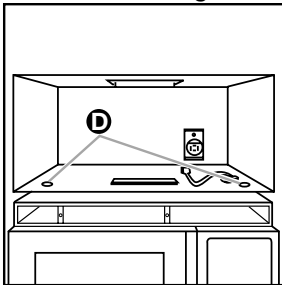

4. Hold microwave hood combination in place with one hand. Pull hook **E** to release microwave hood from mounting plate. If grille cannot be removed (per instructions in step 2.), insert a thin looped wire or similar tool through an opening in grille to pull hook.

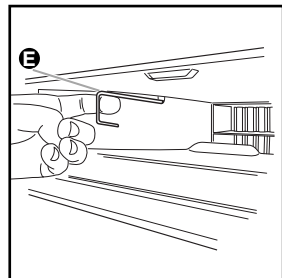

5. Grasp the microwave oven. Rotate the microwave oven downward. (Be careful that door does not swing open.)

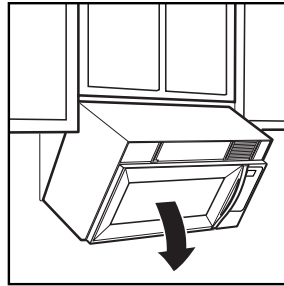

6. Lift off the support tabs **F** at the bottom of the mounting plate. Set the microwave oven aside on a protected surface.



### To replace:

1. Carefully lift microwave oven and hang it on the support tabs at the bottom of the mounting plate.
2. Rotate the front of the microwave oven cabinet downward. Thread the power supply cord through the power supply cord hole in the bottom of the upper cabinet.
3. Rotate the microwave oven towards the cabinet. Push the microwave oven against the mounting plate until locking latch snaps into the cabinet.
4. Replace the two bolts securing the microwave oven to the upper cabinet.
5. Untape the door and replace the turntable and support.
6. Replace the vent grille.
7. Replace the two screws in the top of microwave oven cabinet (the screws located closest to front corners).
8. If filters were installed, replace them (see "Installing and caring for the filters" in the "Caring for Your Microwave Oven" section, if needed).
9. Plug in microwave oven or reconnect power.

# GETTING TO KNOW YOUR MICROWAVE OVEN

This section discusses the concepts behind microwave cooking. It also shows you the basics you need to know to operate your microwave oven. Please read this information before you use your oven.

## Operating tips

- **Never** lean on the door or allow a child to swing on it when the door is open.
- **Use hot pads.** Microwave energy does not heat containers, but the heat from the food can make the container hot.
- **Do not** use newspaper or other printed paper in the oven.
- **Do not** dry flowers, fruit, herbs, wood, paper, gourds, or clothes in the oven.
- **Do not** start a microwave oven when it is empty. Product life may be shortened. If you practice programming the oven, **put** a container of water in the oven. It is normal for the oven door to look wavy after the oven has been running for a while.
- **Do not** try to melt paraffin wax in the oven. Paraffin wax will not melt in a microwave oven because it allows microwaves to pass through it.
- **Do not** operate the microwave oven unless the glass turntable is securely in place and can rotate freely. The turntable can rotate in either direction. **Make sure** the turntable is correct-side up in the oven. **Handle your turntable with care** when removing it from the oven to avoid possibly breaking it. If your turntable cracks or breaks, contact your dealer for a replacement.
- **When you use a browning dish**, the browning dish bottom must be at least  $\frac{3}{16}$ -inch (5.5 mm) above the turntable. Follow the directions supplied with the browning dish.
- **Never cook or reheat a whole egg inside the shell.** Steam buildup in whole eggs may cause them to burst, and possibly damage the oven. **Slice** hard-boiled eggs before heating. In rare cases, poached eggs have been known to explode. **Cover** poached eggs and **allow** a standing time of one minute before cutting into them.
- **For best results, stir any liquid several times during heating or reheating.** Liquids heated in certain containers (especially containers shaped like cylinders) may become overheated. The liquid may splash out with a loud noise during or after heating when stirring or when adding ingredients (coffee granules, tea bags, etc.). This can damage the oven.
- **Microwaves** may not reach the center of a roast. The heat spreads to the center from the outer, cooked areas just as in regular oven cooking. This is one of the reasons for letting some foods (for example, roasts or baked potatoes) stand for a while after cooking, or for stirring some foods during the cooking time.
- **Do not deep fry in the oven.** Microwavable utensils are not suitable and it is difficult to maintain appropriate deep-frying temperatures.
- **Do not overcook potatoes.** At the end of the recommended cooking time, potatoes should be slightly firm because they will continue cooking during standing time. **After microwaving, let** potatoes stand for 5 minutes. They will finish cooking while standing.

## Electrical connection

If your electric power line or outlet voltage is less than 110 volts, cooking times may be longer. Have a qualified electrician check your electrical system.

# GETTING TO KNOW YOUR MICROWAVE OVEN

## Microwave oven features

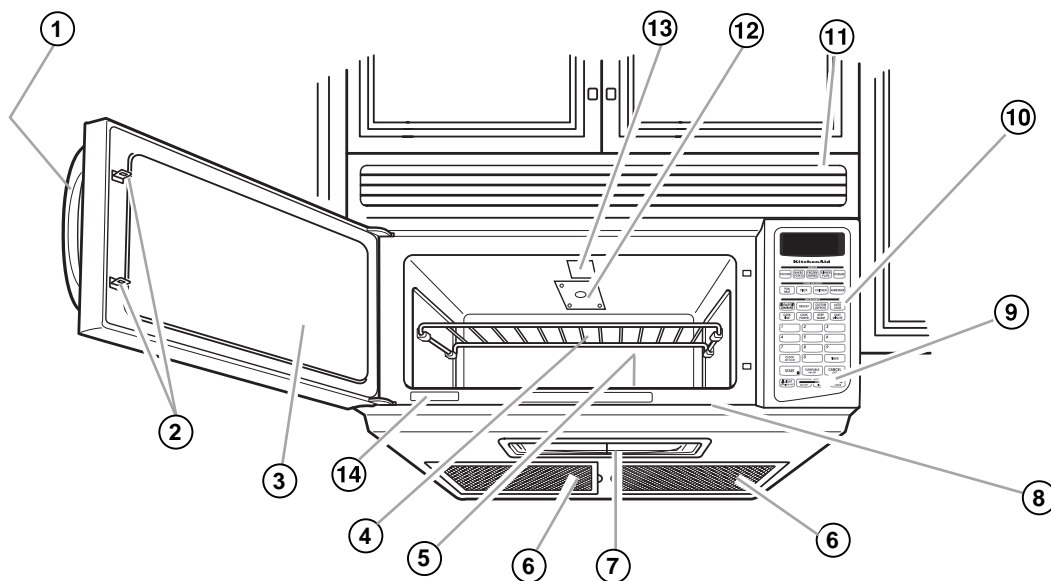

Your microwave oven is designed to make your cooking experience as enjoyable and productive as possible. To help get you up and running quickly, the following is a list of the oven's basic features:

- 1. Door Handle.** Pull to open door.
- 2. Door Safety Lock System.** The oven will not operate unless the door is securely closed.
- 3. Window with Metal Shield.** Shield prevents microwaves from escaping. It is designed as a screen to allow you to view food as it cooks.
- 4. Cooking Rack.** Use for extra space when cooking in more than one container at the same time. (See Page 30.)
- 5. Glass Turntable** (Part No. 4393751) (not shown). Included in oven cavity – see below for installation instructions. This turntable rotates food as it cooks for more even cooking. It must be in the oven during operation for best cooking results. The turntable is sunken into the cavity floor to give you more cooking space and better cooking results.
- 6. Charcoal and Grease Filters.** Packed in oven cavity during shipment. (See Page 31.)
- 7. Cooktop/Countertop Light.** Turn on to light your cooktop or countertop or turn on as a night light. (See Page 12.)
- 8. Cooking Guide Label.** Use as a quick reference for various oven functions.
- 9. Exhaust Fan and Cooktop Light Pads.** (See Page 12.)
- 10. Control Panel.** Touch the pads on this panel to perform all functions.
- 11. Vent Grille.**
- 12. Microwave Inlet Cover.** Do not remove or disturb.
- 13. Oven Cavity Light.**
- 14. Model and Serial Number Plate.**

### To install turntable and support:

- Remove tape holding the hub (Part No. 4393754) in place.
- Place the support (Part No. 4393752) on the cavity in bottom.
- Place the turntable on the hub. Make sure the raised, curved lines in the center of the turntable bottom are between the three "spokes" of the hub.
  - The rollers (Part No. 4393753) on the support should fit inside the ridge on the bottom of the turntable.
- The turntable turns both clockwise and counter-clockwise. This is normal.

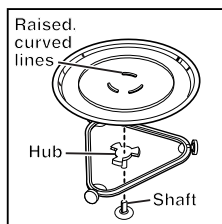

### Crisper pan:

This specially designed microwave pan (Part No. 4393536) lets you cook crispy pizza, sizzle chicken, fry breakfast foods like eggs and sausage, or prepare juicy hamburgers.

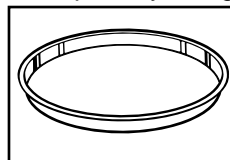

# GETTING TO KNOW YOUR MICROWAVE OVEN

## Control panel features

1. **Display.** This display includes a clock and indicators to tell you the time of day, cooking time settings, and cooking functions you chose.
2. **POPCORN.** Touch this pad to pop one of 3 bag sizes of popcorn, without entering a cook power or time. The oven's sensor will tell the oven how long to cook depending on the amount of humidity it detects from the popcorn. (See Page 27.)
3. **BEVERAGE.** Touch this pad to heat 1 or 2 cups (250 - 500 mL) of a beverage, without entering a cook power or time. The oven's sensor will tell the oven how long to heat depending on the amount of humidity it detects from the beverage. (See Page 27.)
4. **BAKED POTATO.** Touch this pad to bake 1 to 4 potatoes, without entering a cook power or time. The oven's sensor will tell the oven how long to cook depending on the amount of humidity it detects from the potato(es). (See Page 27.)
5. **FROZEN ENTREE.** Touch this pad to cook a 10- or 20-oz (284-567 g) frozen entree, without entering a cook power or time. The oven's sensor will tell the oven how long to cook depending on the amount of humidity it detects from the frozen entree. (See Page 27.)
6. **DINNER PLATE.** Touch this pad to heat a dinner plate of food, without entering a cook power or time. The oven's sensor will tell the oven how long to heat depending on the amount of humidity it detects from the food. (See Page 27.)
7. **PAN HEAT.** Touch this pad to preheat Crisper Pan, without entering a cook power or time. (See Page 28.)
8. **PIZZA.** Touch this pad to heat one of three sizes of pizza, without entering a cook time. Touch COOK POWER to adjust doneness. (See Page 28.)
9. **HAMBURGER.** Touch this pad to cook 1 to 4 hamburgers, without entering a cook time. Touch COOK POWER to adjust doneness. (See Page 28.)
10. **CHICKEN.** Touch this pad to bake 1 to 4 pieces of chicken, without entering a cook time. Touch COOK POWER to adjust doneness. (See Page 28.)
11. **EASY SIMMER.** Touch this pad to simmer soups, casseroles, stews, and other liquid foods. (See Page 21.)
12. **REHEAT.** Touch this pad to reheat microwavable foods without entering times and cook powers. (See Page 22.)
13. **AUTO COOK.** Touch this pad to cook microwavable foods without entering times and cook powers. (See Page 20.)

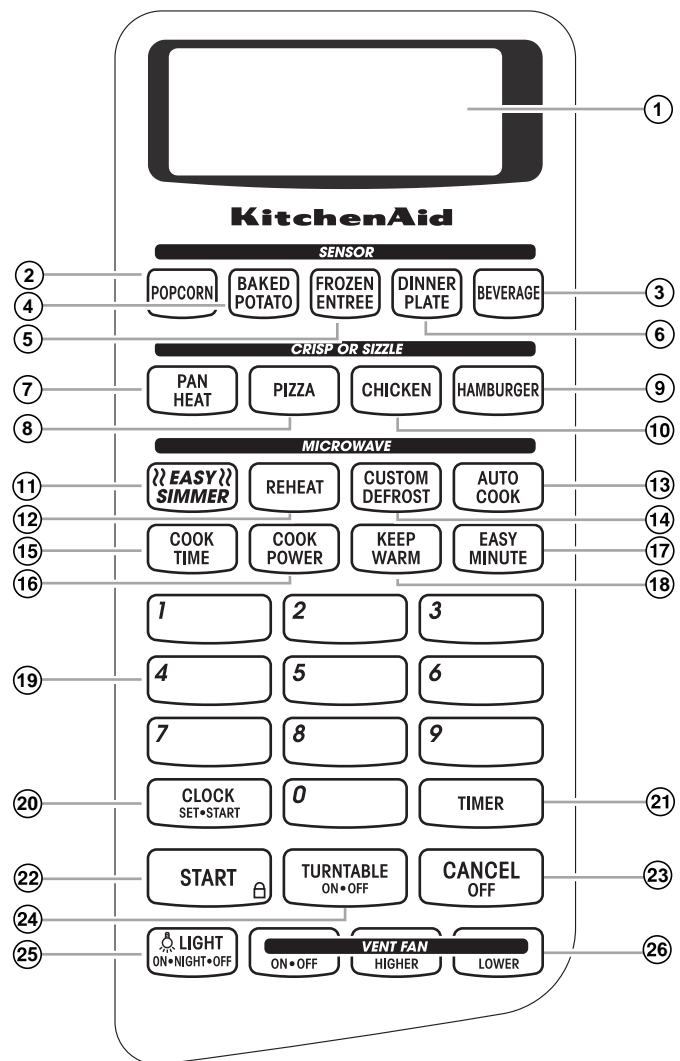

14. **CUSTOM DEFROST.** Touch this pad to defrost frozen foods, without entering times and cook powers. (See Page 23.)
15. **COOK TIME.** Touch this pad followed by Number pads to set a cooking time. (See Pages 15-18.)
16. **COOK POWER.** Touch this pad after the cooking time has been set, followed by a Number pad to set the amount of microwave energy released to cook the food. Also touch this pad to lengthen or shorten a preset cooking time. (See Pages 16-18.)
17. **EASY MINUTE.** Touch this pad to cook food for 1 minute at 100% cook power or to extend cooking time by 1 minute. (See Page 29.)
18. **KEEP WARM.** Touch this pad to keep hot, cooked foods warm in your microwave oven. You can use KEEP WARM by itself, or to automatically follow a cooking cycle. (See Page 26.)

# GETTING TO KNOW YOUR MICROWAVE OVEN

## Control panel features (cont.)

- 19. Number pads.** Touch Number pads to enter cooking times, cook powers, quantities, weights, or food categories.
- 20. CLOCK SET/START.** Touch this pad to enter the correct time of day.
- 21. TIMER.** Touch this pad to set or cancel the Kitchen Timer.
- 22. START.** Touch this pad to start a function.
- 23. CANCEL/OFF.** Touch this pad to erase an incorrect command, cancel a program during cooking, or to clear the display.
- 24. TURNTABLE ON/OFF.** Touch this pad to turn your turntable on and off. (See Page 11.)
- 25. LIGHT ON/NIGHT/OFF.** Touch this pad to turn the light or night light on or off. (See Page 12.)
- 26. VENT FAN ON/OFF higher or lower.** Touch this pad to turn the fan on or off. (See Page 12.)

### NOTES:

- If you have entered all settings for a function but do not touch START/ENTER in 5 seconds, the START? indicator light will show.
- For nonsensor functions, if you open the door while the oven is on and then shut the door within 15 minutes, the START? indicator light will show. Touch START to continue. If you open the door when sensor cooking, cooking is cancelled and you have to start over.
- If you choose a function but do not touch another command pad within 1 minute, the display returns to the time of day and you have to start over.

### Interrupting cooking

You can stop the oven during a cycle by opening the door. The oven stops heating and the fan stops, but the light stays on. To restart cooking, close the door and

#### TOUCH



**If you do not want to continue cooking:**

- Close the door and the light goes off.

**OR**



#### TOUCH



**NOTE:** Before setting a function, touch CANCEL/OFF to make sure no other function is on.

### Audible signals

Your microwave oven comes with audible signals that can guide you when setting and using your oven:

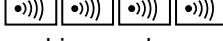
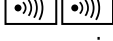
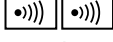
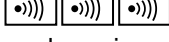
-  A programming tone will sound each time you touch a pad.
-  One long tone signals the end of a Timer countdown.
-  Four tones signal the end of a cooking cycle.
-  Two quick, short tones sound once every minute for the first 15 minutes after an end-of-cooking signal as a reminder if the food has not been removed from the oven.
-  Two quick, short tones will sound while entering and exiting from a hidden feature (for example, Child Lock) or time of day.
-  Three tones sound if you have made an incorrect entry.

**To disable the programming tone:**

#### TOUCH



**and hold for 5 seconds**

**To turn the programming tone back on:**

#### TOUCH



**and hold for 5 seconds**

**To disable all audible signals except the end-of-timer and hidden feature signals:**

#### TOUCH



**and hold for 5 seconds**

**To turn signals back on:**

#### TOUCH



**and hold for 5 seconds**

**NOTE:** Two tones will sound when audible signals are turned on or off.

# GETTING TO KNOW YOUR MICROWAVE OVEN

## Control panel features (cont.)

### Heating more than one plate of food

When heating plates of food with a cook time that you set, you can heat two 10¼-in. (26.7 cm) plates side by side or one dish larger than the turntable. You can heat 2 more plates on the Cooking Rack for a possible total of 4 plates. For best results, halfway through cooking turn the plates halfway around until the food in the front is in the back. Do the same when heating a larger (9- to 13-in. [23 - 33 cm]) casserole. When heating 4 dinner plates turn as described above and switch the top plates with the bottom plates.

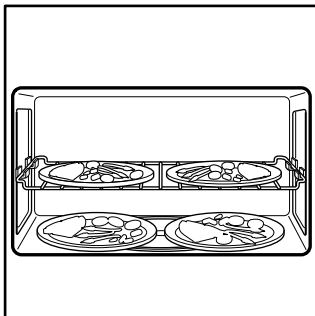

To heat 2 bottom plates together or one larger dish, the turntable should not be turning. You can shut the turntable off by touching TURNTABLE ON/OFF.

“TURNTABLE OFF” appears on the display. If you touch TURNTABLE ON/OFF before starting to set the cooking function, your oven will prompt you to enter a cooking time without you needing to touch COOK TIME. Your turntable will be turned back on when cooking is over or when you touch CANCEL/OFF.

**NOTE:** You cannot turn off the turntable when using an “auto” function.

TURNTABLE  
ON•OFF

## Using the child lock

The Child Lock locks the control panel so children cannot use the microwave oven when you do not want them to.

**To lock the control panel:**

**TOUCH**



**and hold for 5 seconds**

Two tones will sound and  will appear on the display. When the control panel is locked, 3 tones will sound and LOCK will appear when you touch any pad except for EXHAUST FAN and LIGHT, Number pads 1 and 2, and START.

**To unlock the control panel:**

**TOUCH**



**and hold for 5 seconds**

Two tones will sound and  will be cleared from the display.

## Using the demo/learning feature

You can set your microwave oven to display your commands as you enter them without turning the magnetron on. This feature helps you learn to use your oven without actually cooking food.

**To set the demo/learning feature:**

**TOUCH**



**and hold for 5 seconds**

Two tones will sound and a small “d” will appear on the display.

**To cancel the demo/learning feature:**

**TOUCH**



**and hold for 5 seconds**

Two tones will sound and the small “d” will disappear from the display.

# GETTING TO KNOW YOUR MICROWAVE OVEN

## Using the vent fan

The pads on the bottom right of the control panel control the 5-speed exhaust fan.

### NOTES:

- Two seconds after the last time you touch VENT FAN, the display returns to the previous display.
- The first time you turn on the fan after connecting the microwave oven to power, the fan will start at speed 1. The next time the fan is turned on, it will start at the last speed used.

### 1. Turn on the fan and choose fan speed.

Touch the "HIGHER" pad to increase fan speed. Touch the "LOWER" pad to decrease fan speed. The display will show "FAN" and a number from 1 to 5 to indicate fan speed.

**NOTE:** If the temperature from the range or cooktop below the oven gets too hot, the exhaust fan in the vent hood will automatically turn on at the HIGH setting to protect the oven. **It may stay on up to an hour to cool the oven. When this occurs, the VENT FAN pad will not turn the fan off.**

### TOUCH



### 2. Turn off fan when desired.

### TOUCH



## Using the cooktop/countertop light

The pad on the bottom left of the control panel controls the cooktop/countertop light.

### 1. Turn on light.

### TOUCH



(once for regular light, twice for night light)

### 2. Turn off light when desired.

### TOUCH



(1 or 2 more times, depending on light setting)

# GETTING TO KNOW YOUR MICROWAVE OVEN

## Setting the clock

When your microwave oven is first plugged in, or after a power failure, the display will flash “:”. If a time of day is not set, “:” will flash until you touch any pad.

### NOTES:

- If you touch in an invalid time and touch CLOCK, 3 tones will sound. Enter the correct time.
- If you touch CANCEL/OFF while setting the clock, the display will show the last time of day set.
- To turn off the clock, touch CLOCK SET/START, Number pad 0, and CLOCK SET/START again, the set time will disappear and “:” will show on the display.

1. Touch CLOCK SET/START.

### TOUCH



### YOU SEE



2. Enter the time of day.  
Example for 12:00:

### TOUCH

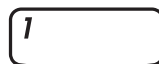

### YOU SEE



3. Touch START pad or CLOCK SET/START pad.

### TOUCH



OR



### YOU SEE



# GETTING TO KNOW YOUR MICROWAVE OVEN

## Using the timer

You can use your microwave oven as a kitchen timer. Use the Timer for timing up to 99 minutes, 99 seconds.

**NOTE:** The oven can operate while the Timer is in use. To see the Timer while the oven is cooking, touch **TIMER**.

1. Touch **TIMER**.

**TOUCH**



**YOU SEE**



2. Enter the time to be counted down.

Example for 1 minute, 30 seconds:

**NOTE:** If you enter more than 4 digits, the first 4 digits will disappear and the following digit(s) will appear on the right side as you enter them.

**TOUCH**



**YOU SEE**



3. Start the countdown.

**NOTE:** If you do not do this step within 5 seconds of doing Step 2, "START?" will appear. You then have 1 minute to touch **TIMER** or **START** before the display returns to the time of day.

**TOUCH**



**OR**



**YOU SEE**



At the end of the countdown:

**YOU SEE**



(one long tone will sound)

**To cancel the timer:**

During the countdown:

**TOUCH**



**OR**



**YOU SEE**



(time of day)

# USING YOUR MICROWAVE OVEN

This section gives you instructions for operating each function. Please read these instructions carefully.

## Cooking at high cook power

1. Put your food in the oven and close the door.

2. Touch COOK TIME.

TOUCH



YOU SEE



3. Enter the cooking time.

Example for 1 minute, 30 seconds:

TOUCH



YOU SEE

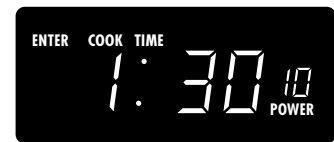

4. Start the oven.

TOUCH



YOU SEE



At the end of the cooking time:

YOU SEE



(four tones will sound)

### Changing instructions

You can change the cooking time any time during cooking by repeating Steps 2, 3, and 4.

# USING YOUR MICROWAVE OVEN

## Cooking at different cook powers

For best results, some recipes call for different cook powers. The lower the cook power, the slower the cooking. Each Number pad also stands for a different percentage of cook power. Many microwave cookbook recipes tell you by number, percent, or name which cook power to use.

The following chart gives the percentage of cook power each Number pad stands for, and the cook power name usually used. It also tells you when to use each cook power. Follow recipe or food package instructions if available.

**NOTE:** Refer to a reliable cookbook for cooking times.

COOK POWER	NAME	WHEN TO USE IT
10=100% of full power (automatic)	High	<ul style="list-style-type: none"> <li>Quick heating many convenience foods and foods with high water content, such as soups, beverages, and vegetables</li> </ul>
9=90% of full power		<ul style="list-style-type: none"> <li>Cooking small tender pieces of meat, ground meat, poultry pieces, and fish fillets</li> <li>Heating cream soups</li> </ul>
8=80% of full power		<ul style="list-style-type: none"> <li>Heating rice, pasta, or casseroles</li> <li>Cooking and heating foods that need a cook power lower than high (for example, whole fish and meat loaf)</li> </ul>
7=70% of full power	Medium-High	<ul style="list-style-type: none"> <li>Reheating a single serving of food</li> </ul>
6=60% of full power		<ul style="list-style-type: none"> <li>Cooking sensitive foods, such as cheese and egg dishes, pudding, and custards</li> <li>Cooking non-stirrable casseroles, such as lasagna</li> </ul>
5=50% of full power	Medium	<ul style="list-style-type: none"> <li>Cooking ham, whole poultry, and pot roasts</li> <li>Simmering stews</li> </ul>
4=40% of full power		<ul style="list-style-type: none"> <li>Melting chocolate</li> <li>Heating bread, rolls and pastries</li> </ul>
3=30% of full power	Medium-Low, Defrost	<ul style="list-style-type: none"> <li>Defrosting foods, such as bread, fish, meats, poultry, and precooked foods</li> </ul>
2=20% of full power		<ul style="list-style-type: none"> <li>Softening butter, cheese, and ice cream</li> </ul>
1=10% of full power	Low	<ul style="list-style-type: none"> <li>Keeping food warm</li> <li>Taking chill out of fruit</li> </ul>

**NOTE:** Once cook time has been entered you can also use the COOK POWER pad as a second Timer by entering "0" for the cook power. The oven will count down the cooking time you set without cooking.

1. Put your food in the oven and close the door.

2. Touch COOK TIME.

**TOUCH**



**YOU SEE**



# USING YOUR MICROWAVE OVEN

## Cooking at different cook powers (cont.)

3. Enter the cooking time.

Example for 7 minutes, 30 seconds:

TOUCH

7

3

0

YOU SEE



4. Set the cook power.

TOUCH

COOK  
POWER

YOU SEE



Example for 50% cook power:

TOUCH

5

OR

COOK  
POWER

(repeat until desired  
cook power appears)

YOU SEE

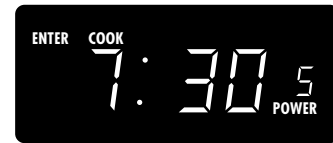

5. Start the oven.

TOUCH

START 

YOU SEE

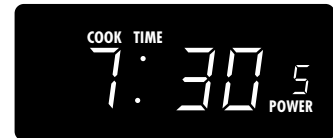

At the end of the cooking time:

YOU SEE



(four tones will sound)

### Changing instructions

You can change the cooking time or cook power any time during cooking by repeating Steps 2, 3 and/or 4 and 5.

# USING YOUR MICROWAVE OVEN

## Cooking in stages

For best results, some recipes call for one cook power for a certain length of time, and another cook power for another length of time. Your oven can be set to change from one to another automatically, for up to 3 stages.

You can set your chosen cook functions in any order. However, if you use CUSTOM DEFROST it must be the first stage.

**NOTE:** You cannot sensor cook with stages.

1. Put your food in the oven and close the door.

2. Touch COOK TIME.

**TOUCH**



**YOU SEE**



3. Enter the cooking time for the first stage.

Example for 7 minutes, 30 seconds:

**TOUCH**



**YOU SEE**

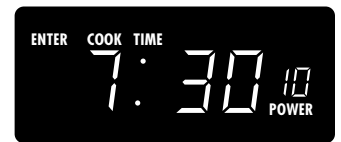

4. Set the cook power for the first stage.

**TOUCH**



**YOU SEE**

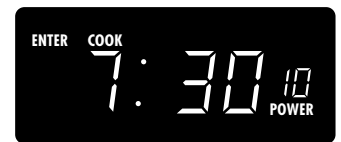

Example for 50% cook power:

**TOUCH**



**OR**



**YOU SEE**

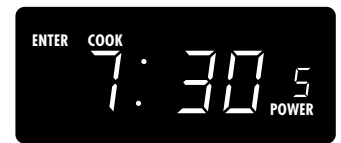

(repeat until desired cook power appears)

5. Repeat Steps 2, 3, and 4 to set the cooking time and cook power for each additional stage.

# USING YOUR MICROWAVE OVEN

## Cooking in stages (cont.)

6. Start the oven.

TOUCH



YOU SEE



(first stage, when cooking with 2 stages)

After the first stage is over, the next stage(s) will count down.

At the end of the cooking time:

YOU SEE



(four tones will sound)

### Changing instructions

You can change cooking times or cook powers for a stage any time after that stage starts by repeating Steps 2, 3 and/or 4 and 5.

# USING YOUR MICROWAVE OVEN

## Using AUTO COOK

You can cook microwavable foods just by choosing a category and quantity. AUTO COOK has preset times and cook powers for 5 categories (see chart below).

To use AUTO COOK, follow the steps below:

1. Touch



once

You see



2. Touch AUTO COOK 1 to 5 times to choose the type of food.



twice

Example  
for canned  
vegetables

OR

Touch a Number pad to choose the type of food.



Example  
for canned  
vegetables

You see



Example  
for canned  
vegetables



3. Touch one or more Number pads to enter the quantity. **This step is not needed for the Rice setting.**



Example  
for 1 cup (250 mL)

You see



Example  
for 1 cup (250 mL)

4. Touch



You see



(countdown time  
may vary)

### NOTES:

- If you do not enter a quantity within 2 seconds, AUTO COOK will prompt you to choose a quantity. You then have 1 minute to enter a quantity and to touch START. If you do not do so, AUTO COOK will be canceled.
- If you touch AUTO COOK 6 times, the display returns to the Rice setting.
- If you need more or less cooking time, do not touch AUTO COOK again. Touch COOK POWER before you touch START. (See “Changing preset cooking times” in the “Using Your Microwave Oven” section.)
- When cooking bacon, keep in mind that differences in the amount of fat, meat, thickness, and curing process will affect how bacon is cooked. Also, regular sliced bacon averages about 16 slices per pound.

This chart shows you how to choose a type of food and the amounts you can choose for each type.

FOOD	TOUCH AUTO COOK*	OR	TOUCH NUMBER PAD	AMOUNTS YOU CAN CHOOSE
Rice (sensor)	once		1	0.5 to 2 cups (125 mL - 500 mL)**
Bacon	twice		2	1 to 6 pieces, average thickness
Cereal (instant)	3 times		3	1 to 4 servings
French Toast (frozen)	4 times		4	1 to 4 pieces
Canned Vegetables	5 times		5	1 to 4 cups (250 mL - 1L)
Fresh Vegetables	6 times		6	1 to 4 cups (250 mL - 1L)**
Frozen Vegetables	7 times		7	1 to 4 cups (250 mL - 1L)**

\* You must touch AUTO COOK once before choosing the food type.

\*\* Because this food is cooked by the sensor, you don't need to enter a quantity. The amount shown here is the amount you can cook. After you choose the food type and touch START, “SENSE” appears on the display. Also, the sensor needs 2 minutes, 30 seconds to warm up after the oven is connected to power or after a power failure. If you start sensor cooking during the warm-up, “SENSE” shows on the display until the warm-up is over. Microwave energy will not be turned on until the sensor is warm.

# USING YOUR MICROWAVE OVEN

## Using EASY SIMMER

Your microwave oven lets you simmer soups, casseroles, stews, and other liquid foods. All you do is set a simmer time and your oven will bring your food to a boil and then simmer it for the time you specify.

### NOTES:

- You cannot change the cook power or doneness for EASY SIMMER.

- This function uses the sensor. The sensor needs 2 minutes, 30 seconds to warm up after the oven is connected to power or after a power failure. If you start EASY SIMMER during the warm-up, microwave energy will not be turned on until the sensor is warm.
- When cooking vegetables, increase amount of water to  $\frac{1}{4}$  to  $\frac{1}{2}$  cup (63 - 125 mL).
- Cover dish with a hard lid, i.e., the lid that comes with the dish or a dinner plate. Do not use plastic wrap.

1. Place the food in the oven and shut the door.

2. Touch EASY SIMMER.

TOUCH



YOU SEE



3. Touch Number pads to enter the simmer time.  
Example for 30 minutes:

TOUCH

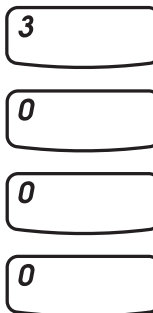

YOU SEE



4. Touch START.

The oven will bring the food to a boil.

TOUCH



YOU SEE



The food will then simmer for the time you set.

YOU SEE



### When simmering foods like pasta

Use a container that can hold enough water to cover the food completely when cooking, such as a 3-quart (12-cup [3 L]) casserole with a lid. When cooking pasta or noodles, add 1 tbsp (14.8 mL) oil to the water before boiling. Use the following method.

Place container with water in the oven and follow Steps 2-4, setting the simmer time at 1 second. At the end of the signal, place the food in the water and stir until completely covered by water. Cover. Repeat Steps 2-4, setting the simmer time you want.

### Changing instructions

You can change the simmering time while simmering by repeating Steps 3 and 4.

# USING YOUR MICROWAVE OVEN

## Using REHEAT

You can reheat microwavable foods just by choosing a category and quantity. REHEAT has preset times and cook powers for 4 categories (see chart below).

To use REHEAT, follow the steps below:

1. Touch



once

You see

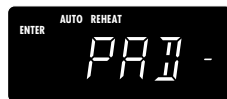

2. Touch REHEAT 1 to 5 times to choose the type of food.



Example for  
casserole

3 times

OR

Touch a Number pad to choose the type of food.



Example for  
casserole

You see

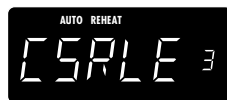

Example for  
casserole



3. Touch a Number pad to enter the quantity.



Example for  
1 cup (250 mL)

You see



Example for  
1 cup (250 mL)

4. Touch



You see

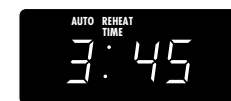

(countdown  
time may  
vary)

### NOTES:

- If you do not enter a quantity within 2 seconds, REHEAT will prompt you to choose a quantity. You then have 1 minute to enter a quantity and to touch START. If you do not do so, REHEAT will be canceled.
- If you touch REHEAT 5 times, the display returns to the Pizza Slice setting.
- If you need more or less cooking time, do not touch REHEAT again. Touch COOK POWER before you touch START. (See “Changing preset cooking times” in the “Using Your Microwave Oven” section.)
- When reheating a large (4 oz [113 g]) muffin or bagel use the 2-piece setting. The 1-piece setting warms 1 regular-size muffin or bagel, or 2 small dinner rolls.

This chart shows you how to choose a type of food and the amounts you can choose for each type.

FOOD	TOUCH AUTO REHEAT*	OR	TOUCH NUMBER PAD	AMOUNTS YOU CAN CHOOSE
<b>Pizza Slice** (sensor)</b>	once		1	1 to 3 slices, 5 oz (127 g) each
<b>Sauce** (sensor)</b>	twice		2	1 to 4 cups (250 mL - 1L)
<b>Casserole</b>	3 times		3	1 to 4 cups (250 mL - 1L)
<b>Baked Goods</b>	4 times		4	1 to 6 pieces, 2 oz (56 g) each
<b>Soup**</b>	5 times		5	1 to 4 cups (250 mL - 1L)

\* You must touch REHEAT once before choosing the food type.

\*\* After you choose the food type and quantity and touch START, “SENSE” appears on the display. Also, the sensor needs 2 minutes, 30 seconds to warm up after the oven is connected to power or after a power failure. If you start sensor cooking during the warm-up, “SENSE” shows on the display until the warm-up is over. Microwave energy will not be turned on until the sensor is warm.

# USING YOUR MICROWAVE OVEN

## Using CUSTOM DEFROST

You can defrost food by choosing a category and setting a weight. CUSTOM DEFROST has preset times and cook powers for 3 categories (see chart below).

To use CUSTOM DEFROST, follow the steps below:

### 1. Touch



once

You see



### 2. Touch CUSTOM DEFROST 1 to 3 times to choose the type of food.



Example for meats

once

OR

Touch a Number pad to choose the type of food.



Example for meats

You see



Example for meats



### 3. Touch Number pad(s) to enter the weight.



Example for 1.1 lbs (.5 kgs)

twice

You see



Example for 1.1 lbs (.5 kgs)

### 4. Touch



You see



(countdown time may vary)

### NOTES:

- If you do not enter a weight within 2 seconds, CUSTOM DEFROST will prompt you to enter a weight. You then have 1 minute to enter a weight and to touch START. If you do not do so, CUSTOM DEFROST will be canceled.
- If you enter a weight higher than the highest weight allowed for your food setting, 3 tones will sound and "RETRY" will appear on the display when you touch START.
- If you touch CUSTOM DEFROST 4 times, the display returns to the Meats setting.
- If you need more or less defrosting time, do not touch CUSTOM DEFROST again. Touch COOK POWER before you touch START. (See "Changing preset cooking times" in the "Using Your Microwave Oven" section.)
- See the "Custom defrost chart" later in this section for defrosting directions for each food.
- To defrost items not listed in the "Custom defrost chart," use 30% cook power. Refer to a reliable cookbook for defrosting information.

### For even, complete defrosting

- The shape of the package affects how quickly food will defrost. Shallow packages will defrost more quickly than a deep block.
- As food begins to defrost, separate the pieces. Separated pieces defrost more evenly.
- Use small pieces of aluminum foil to shield parts of food such as chicken wings, leg tips, fish tails, or areas that start to get warm. Make sure the foil does not touch the sides, top, or bottom of the oven.

This chart shows you how to choose a type of food and the weights you can set for each type.

FOOD	TOUCH CUSTOM DEFROST*	OR TOUCH NUMBER PAD	WEIGHTS YOU CAN SET (tenths of a pound)
Meats	once	1	.1 to 6.6 (45 g - 3 kgs)
Poultry	twice	2	.1 to 6.6 (45 g - 3 kgs)
Fish	3 times	3	.1 to 4.4 (45 g - 2 kgs)

\* You must touch CUSTOM DEFROST once before choosing the food type.

# USING YOUR MICROWAVE OVEN

## Custom defrost chart

### Meat setting

FOOD	SPECIAL INSTRUCTIONS
<b>Beef</b> Ground Beef, Bulk Ground Beef, Patties Round Steak, Tenderloin Steak, Pot Roast, Chuck Roast, Rib Roast, Rolled Rump Roast Stew Beef	Meat of irregular shape and large, fatty cuts of meat should have the narrow or fatty areas shielded with foil at the beginning of a defrost cycle. Do not defrost less than ¼ lb (113 g). Do not defrost less than two 4 oz patties (113 g). Place on a microwavable roasting rack. Place in a microwavable baking dish.
<b>Lamb</b> Cubes for Stew Chops (1 in. [25.4 mm] thick)	Place in a microwavable baking dish. Place on a microwavable roasting rack.
<b>Pork</b> Chops (½ in. [12.7 mm] thick), Hot Dogs, Spareribs, Country- Style Ribs, Loin Roast (Boneless), Sausage, Links Sausage, Bulk	Place on a microwavable roasting rack. Place in a microwavable baking dish.

### Fish setting

FOOD	SPECIAL INSTRUCTIONS
<b>Fish</b> Fillets Steaks Whole	Place in a microwavable baking dish. Carefully separate fillets under cold water. Place in a microwavable baking dish. Run cold water over to finish defrosting. Place in a microwavable baking dish. Cover head and tail with foil; do not let foil touch sides of microwave oven. Finish defrosting by immersing in cold water.
<b>Shell Fish</b> Crabmeat, Lobster Tails, Shrimp, Scallops	Place in a microwavable baking dish.

# USING YOUR MICROWAVE OVEN

## Custom defrost chart (cont.)

### Poultry setting

FOOD	SPECIAL INSTRUCTIONS
<b>Chicken</b>	
Whole (up to 9½ lbs [4.3 kgs])	Place chicken breast-side up on a microwavable roasting rack. Finish defrosting by immersing in cold water. Remove giblets when chicken is partially defrosted.
Cut Up	Place on a microwavable roasting rack. Finish defrosting by immersing in cold water.
<b>Cornish Hens</b>	
Whole	Place on a microwavable roasting rack. Finish defrosting by immersing in cold water.
<b>Turkey</b>	
Breast (under 6 lbs [2.7 kgs])	Place on a microwavable roasting rack. Finish defrosting by immersing in cold water.

### Defrosting tips

- When using CUSTOM DEFROST, you need to enter the net weight (the weight of the food minus the container). Enter the weight to the nearest ¼ lb (45 g).
- Only use CUSTOM DEFROST for raw food. CUSTOM DEFROST gives best results when the food to be thawed is completely frozen. If the food is partially defrosted, always set a lower food weight (for a shorter defrosting time) to prevent cooking the food.
- For better results, a preset standing time is included in the defrosting time. This may make the defrosting time seem longer than expected.

### Weight conversion chart

You are probably used to food weights as being in pounds and ounces that are fractions of a pound (for example 4 ounces equals ¼ lb (113 g). However, in order to enter food weight in CUSTOM DEFROST, you must specify pounds and tenths of a pound.

If the weight on the food package is in fractions of a pound, you can use the following chart to convert the weight to decimals.

DECIMAL WEIGHT	EQUIVALENT OUNCE WEIGHT	EQUIVALENT GRAM WEIGHT
.10	1.6	45
.20	3.2	91
.25 One-Quarter Pound	4.0	113
.30	4.8	136
.40	6.4	181
.50 One-Half Pound	8.0	227
.60	9.6	272
.70	11.2	318
.75 Three-Quarters Pound	12.0	340
.80	12.8	363
.90	14.4	408
1.00 One Pound	16.0	454

# USING YOUR MICROWAVE OVEN

## Using KEEP WARM

### **⚠️ WARNING**

#### **Food Poisoning Hazard**

**Do not let food sit in oven more than one hour before or after cooking.**

**Doing so can result in food poisoning or sickness.**

You can keep hot, cooked food warm in your microwave oven.

#### **NOTES:**

- Opening the oven door cancels KEEP WARM. Close the door and touch KEEP WARM, then touch START if additional Keep Warm time is desired.
- Food cooked covered should be covered during Keep Warm.
- Pastry items (pies, turnovers, etc.) should be uncovered during Keep Warm.
- Complete meals kept warm on a dinner plate should be covered during Keep Warm.
- Do not use more than one complete Keep Warm cycle. The quality of some foods will suffer with extended time.

1. Put hot, cooked food in the oven and close the door.

2. Touch KEEP WARM.

**TOUCH**



**YOU SEE**



3. Start the oven.

**TOUCH**



**YOU SEE**



### **To make KEEP WARM automatically follow another cycle:**

- While entering cooking instructions, touch KEEP WARM before touching START, or during cooking.
- When the last cooking cycle is over, you will hear two tones. "WARM" will come on while the oven continues to run.

# USING YOUR MICROWAVE OVEN

## Sensor cooking

Food releases humidity during cooking/heating. How much humidity food releases is affected by the quantity, temperature, and shape of the food. Your microwave oven has a sensor that detects this humidity. The amount of humidity detected tells the oven how long to cook or heat your food. You can sensor cook when preparing any of 8 types of food. Just touch the pad for the food you want to cook or heat (see the chart below).

### To sensor cook:

1. Touch a Sensor pad.

**BAKED  
POTATO**

Example for baked potato

You see

SENSOR COOK  
**SENSE**

(until cooking time is estimated)

**SENSOR SET TIME  
COUNTS DOWN**

("MAX" appears every 3 seconds)

### NOTES:

- You do not need to touch START to start the oven. The oven will start cooking/heating when you touch one of the Sensor pads.
- If you need more or less cooking time, do not touch the selected Sensor pad again. Touch COOK POWER within 20 seconds after choosing the food type. (See "Changing preset cooking times" in the "Using Your Microwave Oven" section.) You cannot change preset cooking times for POPCORN.
- The sensor needs 2 minutes, 30 seconds to warm up after the oven is connected to power or after a power failure. If you start sensor cooking during the warm-up, "SENSE" shows on the display until the warm-up is over. Microwave energy will not be turned on until the sensor is warm.
- When cooking foods for a long time, allow the oven to cool down before sensor cooking again.

### Popcorn brands make a difference

How well your popcorn cooks will depend on the brand of popcorn and how much fat it has in it. Try several brands to decide which pops the best. For best results, use fresh bags of popcorn.

This chart shows you how to choose a type of food and the amount you can choose for each type.

PAD	INSTRUCTIONS	AMOUNT
<b>Popcorn*</b>	Pop only 1 package at a time. If you are using a microwave popcorn popper, follow manufacturer's instructions.	3.5 oz (99 g), 3.0 oz (85 g), 1.75 oz (50 g)
<b>Baked Potato</b>	Before baking, remember to pierce the potato with a fork several times. After cooking, let the potato stand 5 minutes to finish cooking.	1 to 4 potatoes (10 oz to 13 oz [284 - 369 g] each)
<b>Frozen Entree</b>	Loosen the covering for venting.	10- or 20-ounce (284 - 567 g)
<b>Dinner Plate</b>	Place food to be heated on a dinner plate or similar dish. Cover with plastic wrap and vent.	1 serving (or 1 plate) (0.5 to 1 lb [227 - 454 g])
<b>Beverage*</b>	Do not cover. The shape of the mug will affect how the contents heat – if narrow and tall, contents may be hotter; if more open area on top (i.e., 1-cup measuring cup) contents may be cooler.	1 or 2 8-ounce cups (250 - 500 mL)

\* The display does not show cooking time for this setting. "SENSE" stays on the display until cooking is finished.

# USING YOUR MICROWAVE OVEN

## Using CRISP OR SIZZLE

The PAN HEAT feature, combined with CRISP OR SIZZLE, uses a pan to brown, crisp and pan fry foods in the microwave oven. PAN HEAT preheats the pan to 410°F in approximately 3 minutes. While microwaves heat the food from above, they also heat the pan very quickly from below to brown and crisp food.

**IMPORTANT:** You must use PAN HEAT before using the other CRISP OR SIZZLE features.

### To use PAN HEAT

**1. Touch PAN HEAT once**



Pan will preheat for 3 minutes.

### To use PIZZA

**1. Use PAN HEAT**

**2. Touch**



**once** for 7" (17.78 cm) pizza  
**twice** for 9" (22.86 cm) pizza  
**3 times** for 12" (30.48 cm) pizza

**3. Touch COOK POWER** to adjust cooking time for more or less well done.



**4. Touch START** to begin cooking. (If you do not touch START within 5 seconds after Step 2, cooking will begin automatically.)



### To use CHICKEN

**1. Use PAN HEAT**

**2. Touch**



**once** - 1 piece  
**twice** - 2 pieces  
**3 times** - 3 pieces  
**4 times** - 4 pieces

**3. Touch COOK POWER** to adjust cooking time for more or less well done.



**4. Touch START** to begin cooking. (If you do not touch START within 5 seconds after Step 2, cooking will begin automatically.)



### To use HAMBURGER

**1. Use PAN HEAT**

**2. Touch**



**once** - 1 hamburger  
**twice** - 2 hamburgers  
**3 times** - 3 hamburgers  
**4 times** - 4 hamburgers

**3. Touch COOK POWER** to adjust cooking time for more or less well done.



**4. Touch START** to begin cooking. (If you do not touch START within 5 seconds after Step 2, cooking will begin automatically.)



### Using the pan

**NOTE:** Use the pan only when the turntable is on.

- Use the plastic handle to grasp and remove the pan from the oven.
- Do not use plastic utensils on the pan. The pan becomes very hot quickly and could melt the utensils.
- Do not use any metal utensils, as they can scratch the pan.
- Do not use the pan in any other microwave oven or in a thermal oven.
- Always use the turntable as support for the pan.
- Coat the pan lightly with cooking oil to make removing food and cleaning easier.

### Cleaning the pan

Wash the pan in dishwasher or in mild, soapy water. Avoid abrasive cleansers or scrubbers.

# USING YOUR MICROWAVE OVEN

## Using EASY MINUTE

EASY MINUTE lets you cook food for 1 minute at 100% cook power or add an extra minute to your cooking time cycle. You can also use it to extend cooking time cycles in multiples of 1 minute, up to 99 minutes.

### NOTES:

- To extend cooking time cycles in multiples of 1 minute, touch EASY MINUTE repeatedly during cooking.
- After closing the door, you can enter EASY MINUTE without having to touch START.

- If you touch EASY MINUTE during cooking, the oven will cook at the currently selected cook power. If you touch EASY MINUTE after cooking is over, the oven will cook at 100% cook power. You can also change the cook power after you touch EASY MINUTE by touching COOK POWER, Number pads for the new cook power, and START.
- You can use EASY MINUTE only for the cook time function.

1. Make sure the food is in the oven.

2. Touch EASY MINUTE.

Example for cooking for 1 MINUTE:

### TOUCH



### YOU SEE

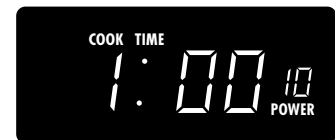

## Changing preset cooking times

If a preset cooking time is too long or too short, you can lengthen or shorten the cooking time after choosing AUTO COOK, REHEAT, CUSTOM DEFROST, or SENSOR (except for the POPCORN setting). For an auto function, you can only change

cooking times after entering a food quantity, but before cooking starts. For sensor cooking, you can only change cooking times within 20 seconds after choosing the food type.

For example, in REHEAT, after choosing the type of food and entering the quantity:

To lengthen cooking time:

### TOUCH



once

### YOU SEE

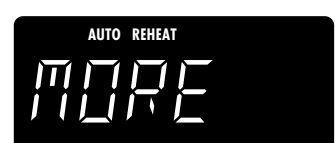

(example for auto reheat)

To shorten cooking time:

### TOUCH



twice

### YOU SEE



To reset to the original cooking time:

### TOUCH



three times

### YOU SEE



# USING YOUR MICROWAVE OVEN

## Using aluminum foil

Metal containers should not be used in a microwave oven. There are, however, some exceptions. If you have purchased food which is prepackaged in an aluminum foil container, refer to the instructions on the package. When using aluminum foil containers, cooking times may be longer because microwaves will only penetrate the top of the food.

If you use aluminum containers without package instructions, follow these guidelines:

- **Place** the container in a glass bowl and add some water so that it covers the bottom of the container, not more than ¼ in. (6.35 mm) high. This ensures even heating of the container bottom.
- **Always remove** the lid to avoid damage to the oven.

- **Use only** undamaged containers.
- **Do not use** containers taller than ¾ in. (19 mm)
- **Container must be** at least half filled.
- **To avoid arcing**, there must be a minimum ¼ in. (6.35 mm) between the aluminum container and the walls of the oven and also between two aluminum containers.
- **Always place** the container on the turntable.
- **Reheating food** in aluminum foil containers usually takes up to double the time compared to reheating in plastic, glass, china, or paper containers. The time when food is ready will vary depending upon the type of container you use.
- **Let food stand** for 2 to 3 minutes after heating so that heat is spread evenly throughout container.

## Cooking you should not do in your microwave oven

- **Do not** do canning of foods in the oven. Closed glass jars may explode, resulting in damage to the oven.
- **Do not** use the microwave oven to sterilize objects (baby bottles, etc.). It is difficult to keep the oven at the high temperature needed for safe sterilization.

## Using 2-4 Plates

When heating food with a cook time that you set, you can heat two 10 ¼-in. (25.5 cm) plates side by side or one dish larger than the turntable, plus two plates on the cooking rack. For best results, halfway through cooking turn the plates halfway around. Do the same when heating a larger (9- to 13-in. [23 - 33 cm]) casserole. When heating 4 dinner plates, switch the plates between top and bottom when you turn them.

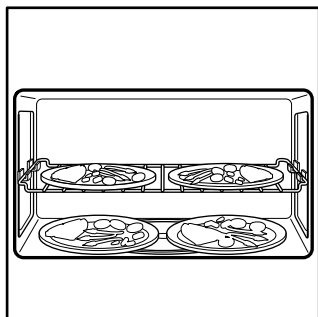

To heat 2 bottom plates together or one larger dish, the turntable should not be turning. You can shut the turntable off by touching TURNTABLE ON/OFF. "TURNTABLE OFF" appears on the display. PRESS to enter setting.



1. TOUCH First Screen pad, TURN to 2-4 Plates and TOUCH.
2. TURN to select number of plates and TOUCH.
3. Arrange plates as shown on left. TOUCH to Start.

**NOTE:** You cannot choose Turntable Off during auto cook functions.

## Using the cooking rack

The cooking rack gives you extra space when cooking in more than one container at the same time.

### Inserting the rack

Insert the rack securely into the rack supports on the side walls of the oven.

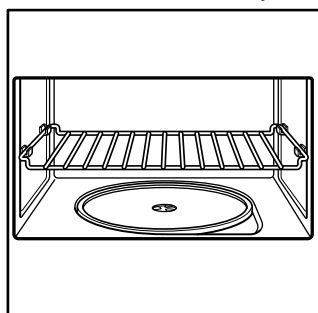

### NOTES:

- Only use the cooking rack when cooking at more than one level.
- Use rack only in the microwave oven.
- Do not let food container on rack touch the top or sides of the oven.
- Do not use rack with browning dish.
- Do not place a metal cooking container on rack.
- Do not store the metal rack in the oven. Do not operate the oven with the metal rack stored on the floor of the oven. Damage to the interior finish will result.
- Use oven mitts to remove items from microwave oven.
- Do not cook foods directly on rack. Put them in microwave-safe containers first.

# CARING FOR YOUR MICROWAVE OVEN

## Installing and caring for filters

The grease filters should be removed and cleaned often, at least once a month.

**NOTE:** Your microwave hood combination comes with a charcoal filter to provide clean recirculated air. **The charcoal filter cannot be cleaned and should be replaced every 6 to 12 months.**

You can order replacements (Part No. 4393690) by calling **1-800-422-1230** and following the instructions and telephone prompts you hear.

If you prefer, you can visit our website at: **www.kitchenaid.com**

### ⚠ WARNING



#### Electrical Shock Hazard

**Disconnect power before removing filters.  
Replace all panels before operating.  
Failure to do so can result in death  
or electrical shock.**

### Removing, cleaning, and replacing

1. Unplug microwave oven or disconnect power.

2. To remove the grease filters (Part No.

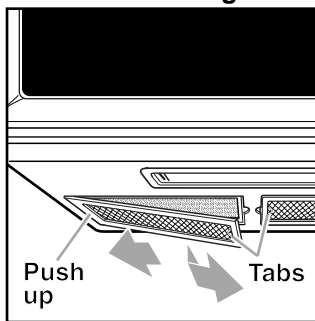

4393691), push each filter up on the side opposite the tab. Grasp the tab and slide the filter to the side. Pull the filter downward. It will drop out.

3. To remove the charcoal filters, push the back of each filter away from you. This will slide the front of the filter off the lower lip. Swing the front of the filter down and slide the filter out.

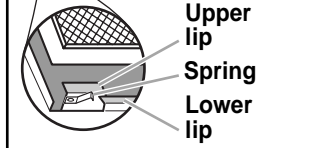

4. Soak grease filters in hot water and a mild detergent. Scrub and swish to remove embedded dirt and grease. Rinse well and shake to dry.

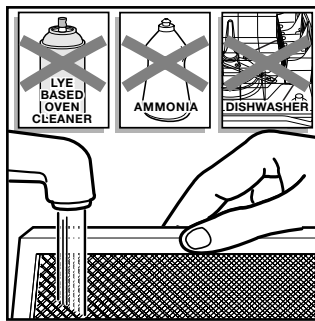

**Do not use ammonia, corrosive cleaning agents such as lye-based oven cleaners, or place in a dishwasher. The filter will turn black or could be damaged.**

5. To replace the charcoal filters, push each filter

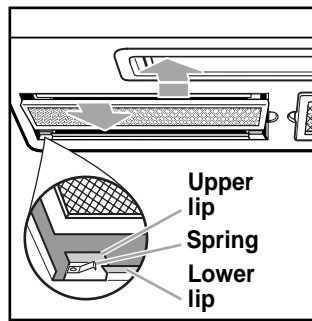

to the back of the opening, between the upper and lower lips against the springs. Swing the front of the filter up against the upper lip. Slide the filter forward while pushing it up against the upper lip. The filter will now be held in position between the lips by the spring.

6. To replace the grease filters, slide each filter into the outer side of the filter opening. Make sure you are sliding in the side of the filter that does not have the tab. Hold the tab with your other hand. Push up the tab side of the filter and slide the filter to the other side of the opening to lock into place.

7. Plug in microwave oven or reconnect power.

**NOTE:** Do *not* operate the vent fan without the grease filters in place.

# CARING FOR YOUR MICROWAVE OVEN

## Replacing the cooktop and oven lights

### The cooktop light

1. Unplug microwave oven or disconnect power.
2. Remove the bulb cover mounting screw and carefully remove the cover.

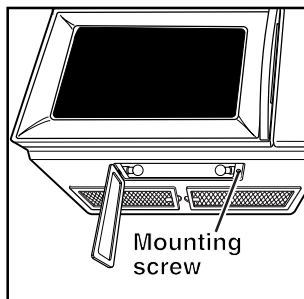

3. Remove the burnt-out bulb(s) and replace with 10W low-voltage halogen capsule bulb(s) (Part No. 8169418). Use a soft tissue to handle bulb(s), or wear a cotton glove. Do not touch bulb(s) with your bare fingers.
4. Replace the bulb cover and mounting screw.
5. Plug in microwave oven or reconnect power..

### The oven light

1. Unplug microwave oven or disconnect power.
2. Remove the two vent grille mounting screws located above the cover (the two outer screws).

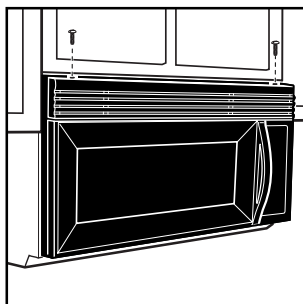

3. Tip the grille forward, then lift out to remove.

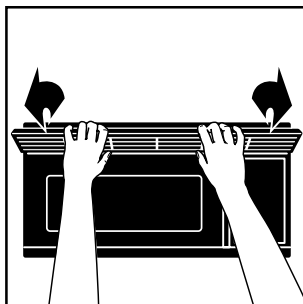

4. Lift up the bulb cover.

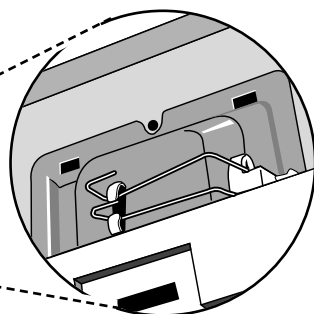
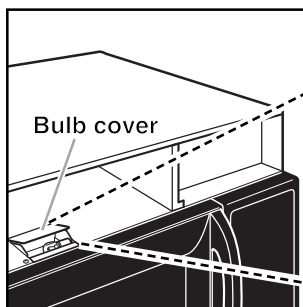

5. Remove the burnt-out bulb by squeezing the wire clip together, pulling to the right and lifting up. Replace the bulb with a 10W low-voltage halogen capsule bulb (Part No. 8169418). Use a soft tissue to handle the lamp, or wear a cotton glove. Do not touch lamp with your bare fingers.

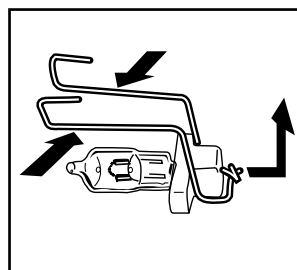

6. Close the bulb cover.

7. Slide the top of the vent grille into place. Push the bottom until it snaps into place. Replace the mounting screws.

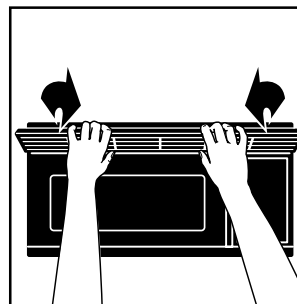

8. Plug in microwave oven or reconnect power.

\* To order bulbs call **1-800-422-1230** and follow the instructions and telephone prompts you hear.

If you prefer, you can visit our website at:  
**www.kitchenaid.com**

# QUESTIONS AND ANSWERS

QUESTIONS	ANSWERS
Can I operate my microwave oven without the turntable or turn the turntable over to hold a large dish?	You can turn off the turntable to heat 2 dinner plates side by side or one dish that's larger than the turntable. However, if you only need to heat one plate on the turntable, keep the turntable on for best cooking results. Also, you should not turn over the turntable. A plate used on the turntable must fit on it when the turntable is correct side up.
Can I use a rack in my microwave oven so that I may reheat or cook on two levels at a time?	You can use a rack only if the rack is supplied with your microwave oven. If you use a rack not supplied with the microwave oven, you can get poor cooking performance and/or arcing.
Can I use either metal or aluminum pans in my microwave oven?	You can use aluminum foil for shielding (use small, flat pieces), small skewers, and shallow foil trays (if tray is $\frac{3}{4}$ in. [19 mm] deep or less and half filled with food to absorb microwave energy). Never allow metal to touch walls or door.
Is it normal for the turntable to turn in either direction?	Yes. The turntable rotates clockwise or counter-clockwise, depending on the rotation of the motor when the cooking cycle begins.
Sometimes the door of my microwave oven appears wavy. Is this normal?	This appearance is normal and does not affect the operation of your oven.
What are the humming noises that I hear when my microwave oven is operating?	You hear the sound of the transformer when the magnetron tube cycles on.
Why does the dish become hot when I microwave food in it? I thought that this should not happen.	As the food becomes hot it will conduct the heat to the dish. Be prepared to use hot pads to remove food after cooking.
Why does steam come out of the air exhaust vent?	Steam is normally produced during cooking. The microwave oven has been designed to vent this steam out the vent.

# TROUBLESHOOTING

Most cooking problems often are caused by little things you can find and fix without tools of any kind. Check the lists below and on the next page before calling for assistance or service. If you still need help, see the “Requesting Assistance or Service” section.

## Microwave oven does not work

PROBLEM	CAUSE
Nothing works.	<ul style="list-style-type: none"><li>• Power cord is not plugged in. Plug into a grounded 3 prong outlet.</li><li>• A household fuse has blown or a circuit breaker has tripped.</li><li>• The electric company has had a power failure.</li></ul>
The microwave oven will not run.	<ul style="list-style-type: none"><li>• You are using the oven as a timer. Touch CANCEL/OFF to cancel the Timer.</li><li>• The door is not firmly closed and latched.</li><li>• You did not touch START at the end of a function.</li><li>• You did not follow directions exactly.</li><li>• An operation that you set earlier is still running. Touch CANCEL/OFF to cancel that operation.</li></ul>

## Cooking times

PROBLEM	CAUSE
Food is not cooked enough.	<ul style="list-style-type: none"><li>• The electric supply to your home or wall outlets is low or lower than normal. Your electric company can tell you if the line voltage is low. Your electrician or service technician can tell you if the outlet voltage is low.</li><li>• The cook power is not at the recommended setting. Check the chart on page 16.</li><li>• You have not allowed enough cooking time for the amount of food being cooked. Larger amounts of food need longer cooking times.</li></ul>
The display shows a time counting down but the oven is not cooking.	<ul style="list-style-type: none"><li>• The oven door is not closed completely.</li><li>• You have set the controls as a timer. Touch TIMER or CANCEL/OFF to cancel the Timer.</li></ul>

## Turntable

PROBLEM	CAUSE
The turntable will not turn.	<ul style="list-style-type: none"><li>• You have turned off the turntable. (See the “Using 2-4 Plates” section on Page 30.)</li><li>• The turntable is not correctly in place. It should be correct-side up and sitting firmly on the center shaft.</li><li>• The support is not operating correctly. Remove the turntable and restart the oven. If the support still does not move, call a designated service technician for repair. Cooking without the turntable can give you poor results.</li></ul>

## Tones

PROBLEM	CAUSE
You do not hear the programming or end-of-cycle tone.	<ul style="list-style-type: none"><li>• You have turned off the tone. (See the “Audible signals” section on Page 10.)</li></ul>

If none of these items are causing your problem, see “Requesting Assistance or Service.”

# REQUESTING ASSISTANCE OR SERVICE

To avoid unnecessary service calls, please check the "Troubleshooting" section. It may save you the cost of a service call. If you still need help, follow the instructions below.

## If you need assistance or service

**Call the KitchenAid Customer Interaction Center**  
toll free at  
**1-800-422-1230.**



When calling:

Please provide KitchenAid with the purchase date, and the complete model and serial number of your appliance (see above). This information will help us better respond to your request.

**Our consultants provide assistance with:**

- Features and specifications on our full line of appliances
- Installation information

- Use and maintenance procedures
- Accessory and repair parts sales
- Specialized customer assistance (Spanish speaking, hearing impaired, limited vision, etc.)
- Referrals to local dealers, service companies, and repair parts distributors

**KitchenAid designated service technicians** are trained to fulfill the product warranty and provide after-warranty service anywhere in the United States.

To locate the KitchenAid designated service company in your area, you can also look in your telephone directory Yellow Pages.

## For further assistance

If you need further assistance, you can write to KitchenAid with any questions or concerns at:

KitchenAid Brand Home Appliances  
Customer Interaction Center  
MD 8020  
553 Benson Road  
Benton Harbor, MI 49022-2400

Please include a daytime phone number in your correspondence.

If you prefer, you can call the Customer Interaction Center at:

**1-800-422-1230**

or, visit our website at:

**[www.kitchenaid.com](http://www.kitchenaid.com)**

# MICROWAVE HOOD WARRANTY

<b>LENGTH OF WARRANTY:</b>	<b>KITCHENAID WILL PAY FOR:</b>
<b>ONE-YEAR FULL WARRANTY FROM DATE OF PURCHASE</b>	Replacement parts and repair labor costs to correct defects in materials or workmanship. Service must be provided by a KitchenAid designated servicing company.
<b>SECOND-THROUGH FIFTH-YEAR LIMITED WARRANTY FROM DATE OF PURCHASE</b>	Replacement of microwave magnetron tube on microwave oven to correct defects in materials or workmanship.
<b>KITCHENAID WILL NOT PAY FOR:</b>	
<p><b>A.</b> Service calls to:</p> <ol style="list-style-type: none"> <li>1. Correct the installation of the oven.</li> <li>2. Instruct you how to use the oven.</li> <li>3. Replace house fuses or correct house wiring.</li> <li>4. Service to replace customer-accessible light bulbs and filters.</li> </ol> <p><b>B.</b> Repairs when oven is used in other than normal, single-family home use.</p> <p><b>C.</b> Damage resulting from accident, alteration, misuse, abuse, fire, flood, acts of God, improper installation, or installation not in accordance with local electrical codes, or use of products not approved by KitchenAid.</p> <p><b>D.</b> Replacement of disposable charcoal filter and browning pan that require replacement due to normal use.</p> <p><b>E.</b> Any labor costs during the limited warranty.</p> <p><b>F.</b> Pickup and delivery. This product is designed to be repaired in the home.</p> <p><b>G.</b> Repairs to parts or systems resulting from unauthorized modifications made to the appliance.</p> <p><b>H.</b> Replacement parts or repair labor costs for units operated outside the United States.</p>	

7/00

**KITCHENAID DOES NOT ASSUME ANY RESPONSIBILITY FOR INCIDENTAL OR CONSEQUENTIAL DAMAGES.**

Some states do not allow the exclusion or limitation of incidental or consequential damages, so this exclusion or limitation may not apply to you. This warranty gives you specific legal rights and you may also have other rights which may vary from state to state.

**Outside the 50 United States, this warranty does not apply. Contact your authorized KitchenAid dealer to determine if another warranty applies.**

If you need service, first see the "Troubleshooting" section of this book. After checking "Troubleshooting," additional help can be found by checking the "Requesting Assistance or Service" section or by calling our Customer Interaction Center telephone number, **1-800-422-1230**, from anywhere in the United States.