

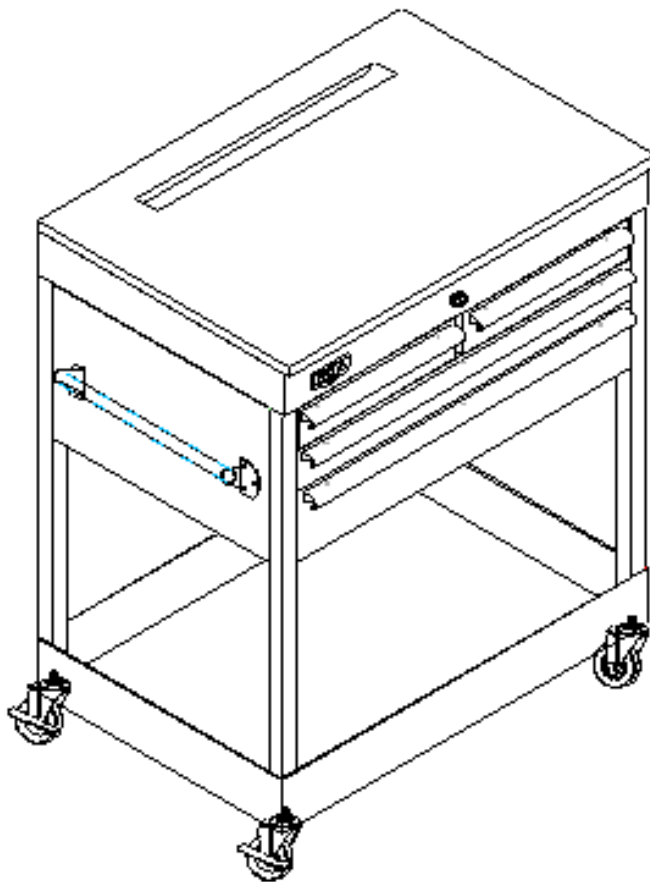

# Owner's Manual

## 30 in. mobile cart



**Model No.960-0007**

**Customer Service Department:**

Nexgrill Industries Inc.

280 Machlin Court

City of Industry, CA 91789 USA

Toll Free Number: 1-866-984-7455.

Office Hours: 8 a.m. – 5 p.m. P.S.T.

<http://www.nexgrill.net>

# Exploded View of 960-0007

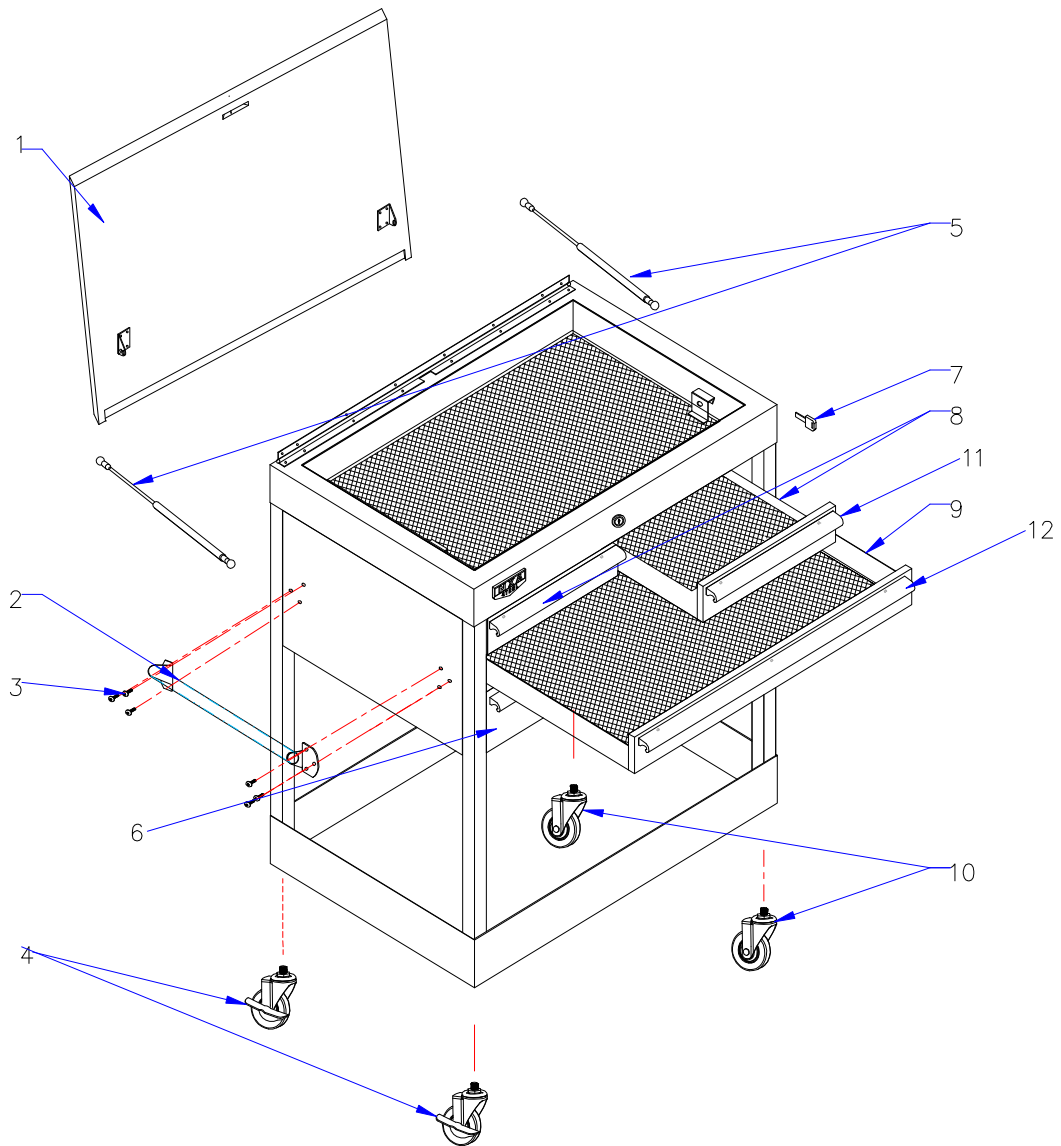

## Part list

Part Name	Quantity
1. Solid Birch Wood Top Part number: _16000200A0	1
2. Side Handle Part number: _20001269A0	1
3. Screw (1/4*12) Part number: 06000484A0	2
4. Caster with Brake Part number: _05000182A0	1
5. Hydraulic Lift Part number: _05001141A0	2
6. Bottom drawer Part number: _20001281A0	1
7. Key Part number: _05001515A0	1
8. Top drawer Part number: _20001270A0	2
9. Middle drawer Part number: _20001271A0	1
10. Swivel Caster Part number: 05000330A0	2
11. Small drawer handle Part number: _12000622A0	2
12. Big drawer handle Part number: _12000623A0	2

## Assembly Instruction

### 1. Handle Installation:

Take out the 6 screws from the hardware pack, line up the handle with the holes, insert the screws and firmly tighten the screws.

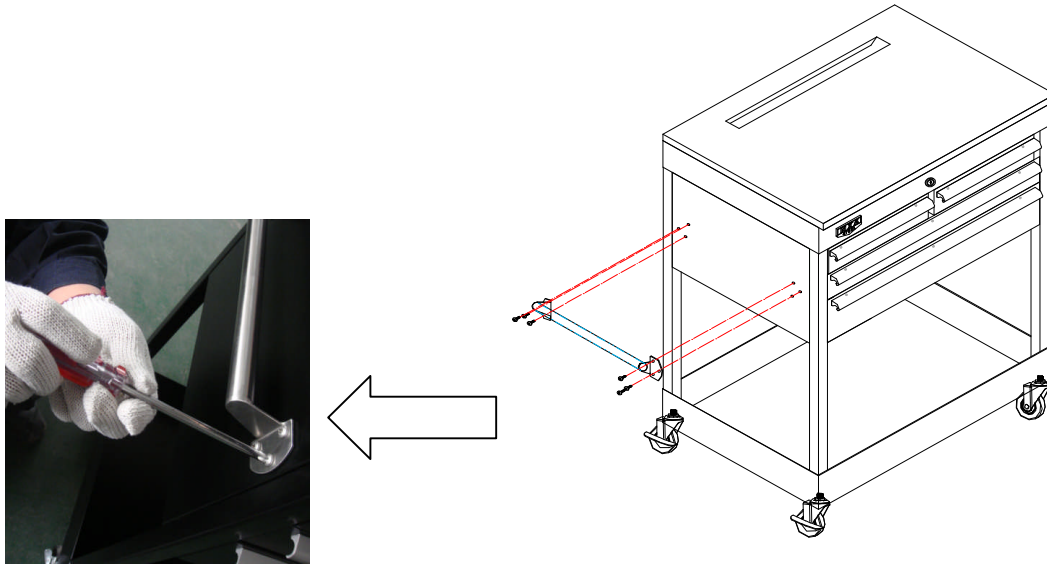

### 2. Wheels Installation:

Push the post on each caster in to the receptacle in each leg until it is firmly seated (2 casters with brake on the left hand side when facing the cart).

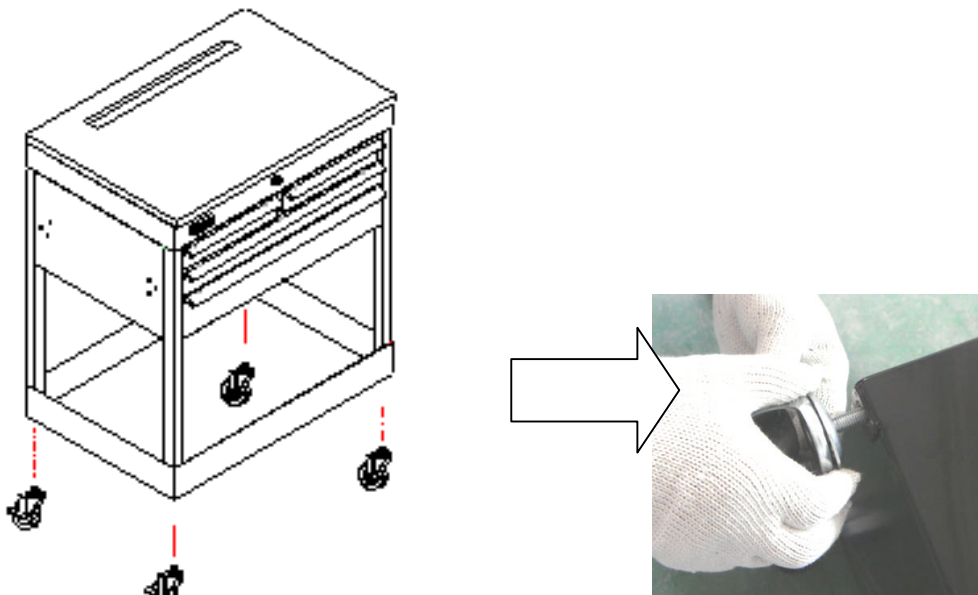

## **-How to remove the drawer?**

Slide the drawer out until it is fully extended. Note the black plastic levers on both sides of the drawer. Depress the levers and then slide the drawer out.

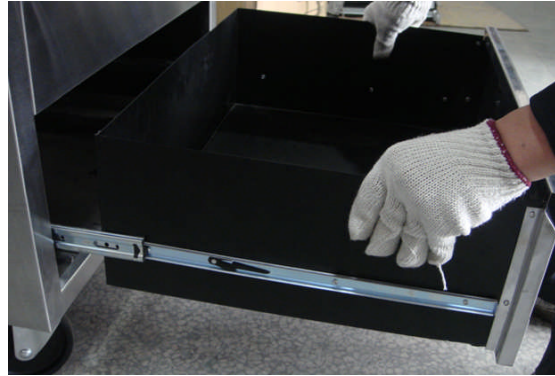

## **CAUTION**

- **Do not use the drawers when the lid is locked**
- **Close the drawers before close the lid if you want to lock them.**
- **Assemble the side handle to make it easier to move the mobile cart.**

**\*\*PLEASE DO NOT RETURN THIS PRODUCT TO THE RETAILER\*\***

should you encounter issues, are missing parts, or need operating assistance. *The Grill Services* will be happy to send replacement parts and troubleshoot issues to help ensure your product is in great quality for years to come. *Simply call 866-984-7455 for great service between 8AM & 5PM, Mon-Fri.*

---

## LIMITED WARRANTY, Model 960-0007

Nexgrill Industries warrants to the original consumer-purchaser only that this product (**Model #960-0007**) shall be free from defects in workmanship and materials after correct assembly and under normal and reasonable home use for the periods indicated below beginning on the date of purchase. The manufacturer reserves the right to require that defective parts be returned, postage and or freight pre-paid, by the consumer, for review and examination. **Please retain your receipt or proof of purchase, as it may be needed as documentation that you are the original purchaser for extended warranty coverage.**

- **All PARTS: 1 Year LIMITED warranty**  
*\*Does not cover cosmetic issues like surface corrosion, scratches and rust.*

Upon consumer supplying proof of purchase as provided herein, Manufacturer will repair or replace the parts which are proven defective during the applicable warranty period. Parts required to complete such repair or replacement shall be free of charge to you except for shipping costs, as long as the purchaser is within the warranty period from the original date of purchase. **The original consumer-purchaser will be responsible for all shipping charges (and customs charges in Canada) of parts replaced under the terms of this limited warranty.** This limited warranty is applicable in the United States and Canada only, is only available to the original owner of the product and is *not transferable*. **Manufacturer requires reasonable proof of your date of purchase. Therefore, you should retain your sales receipt and/or invoice.** Defective or missing parts subject to this limited warranty will not be replaced without registration or proof of purchase. This limited warranty applies to the functionality of the product ONLY and does not cover cosmetic issues such as scratches, dents, corruptions or discoloring by heat, abrasive and chemical cleaners or any tools used in the assembly or installation of the appliance, surface rust, or the discoloration of stainless steel surfaces. Surface rust, corrosion, or powder paint chipping on metal parts that does not affect the structural integrity of the product is not considered a defect in workmanship or material and is not covered by this warranty. This limited warranty will not reimburse you for the cost of any inconvenience, food, personal injury or property damage. If an original replacement part or product is not available, a comparable replacement part or product will be provided.

### ITEMS MANUFACTURER WILL NOT PAY FOR:

1. Service calls to your home, business, or general location of the product.
2. Repairs when your product is used for other than normal, single-family household or residential use.
3. Damage resulting from accident, alteration, misuse, abuse, fire, flood, acts of God, improper installation, and installation not in accordance with electrical or plumbing codes or use of products not approved by the manufacturer; including incorrect installation or fuel conversions not performed by the manufacturer's designated service provider;
4. Any food loss due to product failures.
5. Replacement parts or repair labor costs for units operated outside the United States or Canada.
6. Pickup and delivery of your product.
7. Repairs to parts or systems resulting from unauthorized modifications made to the product.
8. The removal and/or reinstallation of your product.
9. Shipping and customs cost, standard or expedited, for warranty/non warranty and replacement parts; and shipping costs for photographic evidence or damaged parts requested to verify need for warranty coverage.

### DISCLAIMER OF IMPLIED WARRANTIES; LIMITATION OF REMEDIES

Repair or replacement of defective parts is your exclusive remedy under the terms of this limited warranty. Manufacturer will not be responsible for any consequential or incidental damages arising from the breach of either this limited warranty or any applicable implied warranty, or for failure or damage resulting from acts of God, improper care and maintenance, grease fire, accident, alteration, replacement of parts by anyone other than Manufacturer, misuse, transportation, commercial use, abuse, hostile environments (inclement weather, acts of nature, animal tampering), improper installation or installation not in accordance with local codes or printed manufacturer instructions.

THIS LIMITED WARRANTY IS THE SOLE EXPRESS WARRANTY GIVEN BY THE MANUFACTURER. NO PRODUCT PERFORMANCE SPECIFICATION OR DESCRIPTION WHEREVER APPEARING IS WARRANTED BY MANUFACTURER EXCEPT TO THE EXTENT SET FORTH IN THIS LIMITED WARRANTY. ANY IMPLIED WARRANTY PROTECTION ARISING UNDER THE LAWS OF ANY STATE, INCLUDING IMPLIED WARRANTY OF MERCHANTABILITY OR FITNESS FOR A PARTICULAR PURPOSE OR USE, IS HEREBY LIMITED IN DURATION TO THE DURATION OF THIS LIMITED WARRANTY.

**Neither dealers nor the retail establishment selling this product has any authority to make any additional warranties or to promise remedies in addition to or inconsistent with those stated above.** Manufacturer's maximum liability, in any event, shall not exceed the documented purchase price of the product paid by the original consumer. **This warranty only applies to units purchased from an authorized retailer and or re-seller.** NOTE: Some states do not allow an exclusion or limitation of incidental or consequential damages, so some of the above limitations or exclusions may not apply to you; this limited warranty gives you specific legal rights as set for herein. You may also have other rights which vary from state to state.

If you wish to obtain performance of any obligation under this limited warranty, you should write to:  
(Via Postal Mail) Nexgrill Industries Customer Relations, 280 Machlin Court, City of Industry, CA 91789, USA  
(Via Electronic Mail) [customerservice@grillservices.com](mailto:customerservice@grillservices.com)

**All consumer returns, parts orders, questions, and troubleshooting assistance can be acquired by calling 1-866-984-7455.**