

This Owner's Manual is provided and hosted by Appliance Factory Parts.

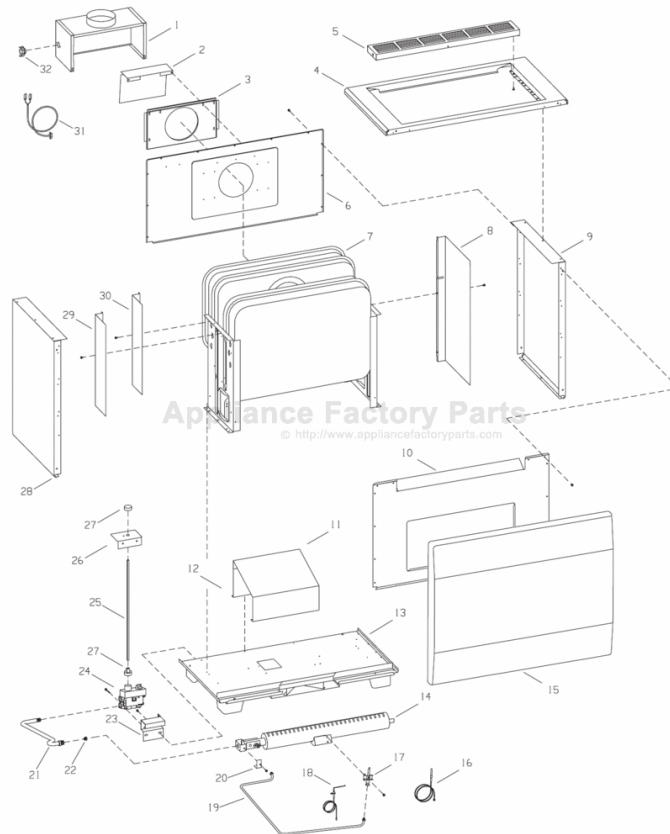

EMPIRE RH-50C Owner's Manual

[Shop genuine replacement parts for EMPIRE RH-50C](#)



[Find Your EMPIRE HVAC Parts - Select From 82 Models](#)

----- Manual continues below -----



INSTALLATION INSTRUCTIONS AND OWNER'S MANUAL

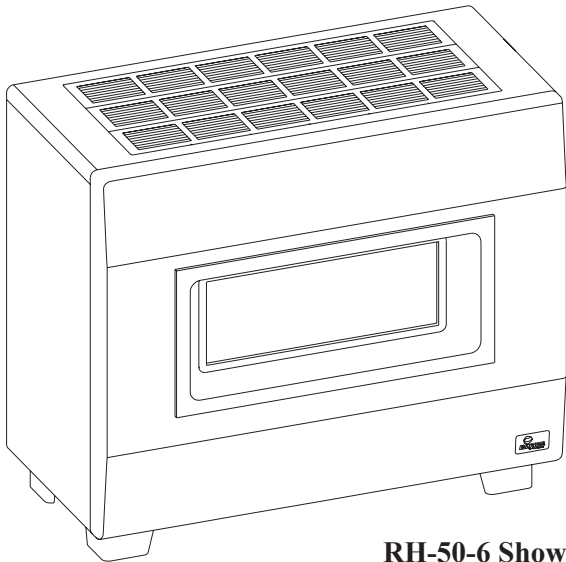

RH-50-6 Shown

VENTED ROOM HEATER

MODELS

RH-50-6
RH-50C-1

RH-65-6
RH-65C-1



WARNING: If the information in these instructions are not followed exactly, a fire or explosion may result causing property damage, personal injury or loss of life.

- Do not store or use gasoline or other flammable vapors and liquids in the vicinity of this or any other appliance.
- **WHAT TO DO IF YOU SMELL GAS**
 - Do not try to light any appliance.
 - Do not touch any electrical switch; do not use any phone in your building.
 - Immediately call your gas supplier from a neighbor's phone. Follow the gas supplier's instructions.
 - If you cannot reach your gas supplier, call the fire department.
- Installation and service must be performed by a qualified installer, service agency or the gas supplier.

Installer: Leave this manual with the appliance.

Consumer: Retain this manual for future reference.

WARNING: If not installed, operated and maintained in accordance with the manufacturer's instructions, this product could expose you to substances in fuel or from fuel combustion which can cause death or serious illness.

TABLE OF CONTENTS

SECTION	PAGE
Important Safety Information.....	3
Safety Information for Users of LP Gas.....	4
Introduction.....	5
Specifications.....	5
Gas Supply.....	6
Clearances.....	7
Venting.....	7
Vent Safety Shutoff System.....	8
Reversible Vertical or Horizontal Diverter.....	8
Thermostat Operation.....	8
Lighting Instructions.....	9
Pilot Flame Characteristics.....	10
Main Burner Flame Characteristics.....	10
Maintenance.....	11
Troubleshooting.....	11
Parts List RH-50 & RH-65.....	12
Parts View RH-50 & RH-65.....	13
Parts List RH-50C & RH-65C.....	14
Parts View RH-50C & RH-65C.....	15
Optional Blower Installation Instructions.....	16-17
Master Parts Distributor List.....	18
How To Order Repair Part.....	18
Service Notes.....	19

IMPORTANT SAFETY INFORMATION

THIS IS A HEATING APPLIANCE

DO NOT OPERATE THIS APPLIANCE WITHOUT FRONT PANEL INSTALLED.

- Due to high temperatures, the room heater should be located out of traffic and away from furniture and draperies.
- Children and adults should be alerted to the hazards of high surface temperature and should stay away to avoid burns or clothing ignition.
- Young children should be carefully supervised when they are in the same room as the room heater.
- Clothing or other flammable material should not be placed on or near the room heater.
- Due to high surface temperatures, keep children, clothing and furniture away.
- Keep burner and control compartment clean.
- Installation and repair should be done by a **QUALIFIED SERVICE PERSON**. The room heater should be inspected before use and at least annually by a qualified service person. More frequent cleaning may be required due to excessive lint from carpeting, bedding material, etc. It is imperative that control compartments, burners and circulating air passageways of the room heater be kept clean.
- **DO NOT** put anything around the heater that will obstruct the flow of combustion and ventilation air. See clearances.
- **DO** keep the appliance area clear and free from combustible material, gasoline and other flammable vapors and liquids.
- **DO** examine burners periodically. Clean and replace damaged parts.
- **DO NOT** use this heater if any part has been under water. Immediately call a qualified service technician to inspect the heater and to replace any part of the control system and any gas control which has been under water.
- **WARNING:** Any change to this room heater or its controls can be dangerous. Any safety screen or guard removed for servicing a room heater must be replaced prior to operating the room heater.

SAFETY INFORMATION FOR USERS OF LP-GAS

Propane (LP-Gas) is a flammable gas which can cause fires and explosions. In its natural state, propane is odorless and colorless. You may not know all the following safety precautions which can protect both you and your family from an accident. Read them carefully now, then review them point by

point with the members of your household. Someday, when there may not be a minute to lose, everyone's safety will depend on knowing exactly what to do. If, after reading the following information, you feel you still need more information, please contact your gas supplier.

LP-GAS WARNING ODOR

If a gas leak happens, you should be able to smell the gas because of the odorant put in the LP-Gas. That's your signal to go into immediate action!

- Do not operate electric switches, light matches, use your phone. Do not do anything that could ignite the gas.
- Get everyone out of the building vehicle, trailer, or area. Do that IMMEDIATELY.
- Close all gas tank or cylinder supply valves.
- LP-Gas is heavier than air and may settle in low areas such as basements. When you have reason to suspect a gas leak, keep out of basements and other low areas. Stay out until firefighters declare them to be safe.
- Use your neighbor's phone and call a trained LP-Gas service person and the fire department. Even though you may not continue to smell gas, do not turn on the gas again. Do not re-enter the building, vehicle, trailer, or area.
- **Finally**, let the service man and firefighters check for escaped gas. Have them air out the area before you return. Properly trained LP-Gas service people should repair the leak, then check and relight the gas appliance for you.

NO ODOR DETECTED - ODOR FADE

Some people cannot smell well. Some people cannot smell the odor of the chemical put into the gas. You must find out if you can smell the odorant in propane. Smoking can decrease your ability to smell. Being around an odor for a time can affect your sensitivity or ability to detect that odor. Sometimes other odors in the area mask the gas odor. People may not smell the gas odor or their minds are on something else. Thinking about smelling a gas odor can make it easier to smell.

The odorant in LP-gas is colorless, and it can fade under some circumstances. For example, if there is an underground leak, the movement of the gas through soil can filter the odorant. Odorants in LP-gas also are subject to oxidation. This fading can occur if there is rust inside the storage tank or in iron gas pipes.

The odorant in escaped gas can adsorb or absorb onto or into walls, masonry and other materials and fabrics in a room. That will take some of the odorant out of the gas, reducing its odor intensity.

LP-gas may stratify in a closed area, and the odor intensity could vary at different levels. Since it is heavier than air, there may be more odor at lower levels. Always be sensitive to the slightest gas odor. If you detect any odor, treat it as a serious leak. Immediately go into action as instructed earlier.

SOME POINTS TO REMEMBER

- **Learn to recognize the odor of LP-gas.** Your local LP-Gas Dealer can give you a "Scratch and Sniff" pamphlet. Use it to find out what the propane odor smells like. If you suspect that your LP-gas has a weak or abnormal odor, call your LP-gas dealer.
- If you are not qualified, do not light pilot lights, perform service, or make adjustments to appliances on the LP-gas system. If you are qualified, consciously think about the odor of LP-gas prior to and while lighting pilot lights or performing service or making adjustments.
- Sometimes a basement or a closed-up house has a musty smell that can cover up the LP-gas odor. Do not try to light pilot lights, perform service, or make adjustments in an area where the conditions are such that you may not detect the odor if there has been a leak of LP-gas.
- Odor fade, due to oxidation by rust or adsorption on walls of new cylinders and tanks, is possible. Therefore, people should be particularly alert and careful when new tanks or cylinders are placed in service. Odor fade can occur in new tanks, or reinstalled old tanks, if they are filled and allowed to set too long before refilling. Cylinders and tanks which have been out of service for a time may develop internal rust which will cause odor fade. If such conditions are suspected to exist, a periodic sniff test of the gas is advisable. **If you have any question about the gas odor, call your LP-gas dealer. A periodic sniff test of the LP-gas is a good safety measure under any condition.**
- If, at any time, you do not smell the LP-gas odorant and you think you should, assume you have a leak. Then take the same immediate action recommended above for the occasion when you do detect the odorized LP-gas.
- If you experience a complete "gas out," (the container is under no vapor pressure), turn the tank valve off immediately. If the container valve is left on, the container may draw in some air through openings such as pilot light orifices. If this occurs, some new internal rusting could occur. If the valve is left open, then treat the container as a new tank. Always be sure your container is under vapor pressure by turning it off at the container before it goes completely empty or having it refilled before it is completely empty.

INTRODUCTION

Introduction

Always consult your local Building Department regarding regulations, codes or ordinances which apply to the installation of a vented room heater.

Instructions to Installer

1. Installer must leave instruction manual with owner after installation.
2. Installer must have owner fill out and mail warranty card supplied with heater.
3. Installer should show owner how to start and operate heater and thermostat.

General Information

This series is design certified in accordance with American National Standard/CSA Standard Z21.86 and CSA 2.32 by the Canadian Standards Association, as a Vented Room Heater and must be installed according to these instructions.

Any alteration of the original design, installed other than as shown in these instructions or use with a type of gas not shown on the rating plate is the responsibility of the person and company making the change.

Important

All correspondence should refer to complete Model Number, Serial Number and type of gas.

Notice: During initial firing of this unit, its paint will bake out and smoke will occur. To prevent triggering of smoke alarms, ventilate the room in which the unit is installed.

Installation on Rugs and Tile

If this appliance is to be installed directly on carpeting, tile, or other combustible material, other than wood flooring, the appliance shall be installed on a metal or wood panel extending the full width and depth of the appliance.

The base referred to above does not mean the fire-proof base as used on wood stoves. The protection is primarily for rugs that may be extremely thick and light-color tile that can discolor.

Floor pad is available from Empire Comfort Systems, Inc., Part Number RH-425.

Qualified Installing Agency

Installation and replacement of gas piping, gas utilization equipment or accessories and repair and servicing of equipment shall be performed only by a qualified agency. The term "qualified agency" means any individual, firm, corporation, or company which whether in person or through a representative is engaged in and is responsible for (1) the installation or replacement of gas piping or (b) the connection, installation, repair or servicing of equipment, who is experienced in such work, familiar with all precautions required and has complied with all the requirements of the authority having jurisdiction.

State of Massachusetts: The installation must be made by a licensed plumber or gas fitter in the Commonwealth of Massachusetts

The installation must conform with local codes, or in the absence of local codes, with the National Fuel Gas Code, ANSI Z223.1*/Canadian Installation Code, CAN/CGA B149.

**Available from the American National Standards Institute, Inc., 11 West 42nd St., New York, N.Y. 10036*

High Altitudes

For altitudes/elevations above 2,000 feet (610m), input ratings should be reduced at the rate of 4 percent for each 1,000 feet (305m) above sea level. **Canadian High Altitudes** for locations having an elevation above mean sea level between 2,000 feet (610m) and 4,500 feet (1370m), the manifold pressure is to be decreased from 4.0" w.c. (.996kPa) to 3.2" w.c. (.797kPa) for Natural Gas and from 10.0" w.c. (2.49kPa) to 8.0" w.c. (1.99kPa) for Propane Gas.

SPECIFICATIONS

Models	RH-50B	RH-65B	RH-50C	RH-65C	RH-50CB	RH-65CB
Input BTU/HR (KW/H)	50,000 (14.6)	65,000 (19)	50,000 (14.6)	65,000 (19)	50,000 (14.6)	65,000 (19)
Height	29 9/16" (751mm)	29 9/16" (751mm)	29 9/16" (751mm)	29 9/16" (751mm)	29 9/16" (751mm)	29 9/16" (751mm)
Width	34" (864mm)	34" (864mm)	34" (864mm)	34" (864mm)	34" (864mm)	34" (864mm)
Depth including diverter	23 3/16" (589mm)	27 11/16" (704mm)	23 3/16" (589mm)	27 11/16" (704mm)	23 3/16" (589mm)	27 11/16" (704mm)
Gas Inlet	1/2" (13mm)	1/2" (13mm)	1/2" (13mm)	1/2" (13mm)	1/2" (13mm)	1/2" (13mm)
Size Draft Diverter Collar	5" (127mm)	5" (127mm)	5" (127mm)	5" (127mm)	5" (127mm)	5" (127mm)
Floor to top of collar on vertical position of Draft Diverter	27 5/32" (690mm)	27 5/32" (690mm)	27 5/32" (690mm)	27 5/32" (690mm)	27 5/32" (690mm)	27 5/32" (690mm)
Floor to center of collar on horizontal position of Draft Diverter	22 9/16" (573mm)	22 9/16" (573mm)	22 9/16" (573mm)	22 9/16" (573mm)	22 9/16" (573mm)	22 9/16" (573mm)
Accessories						
Blower Package	Included	Included	FRB-3	FRB-3	Included	Included
Radiant Package	RAD-8	RAD-8	N/A	N/A	N/A	N/A
Floor Pad	RH-425	RH-425	RH-425	RH-425	RH-425	RH-425
Ceramic Log	RHL-1	RHL-1	N/A	N/A	N/A	N/A

GAS SUPPLY

Recommended Gas Pipe Diameter

Pipe Length	Schedule 40 Pipe Inside Diameter		Tubing, Type L Outside Diameter	
	Nat.	L.P.	Nat.	L.P.
0-10 feet 0-3 meters	1/2"	3/8"	1/2"	3/8"
10-40 feet 4-12 meters	1/2"	1/2"	5/8"	1/2"
40-100 feet 13-30 meters	1/2"	1/2"	3/4"	1/2"
100-150 feet 31-46 meters	3/4"	1/2"	7/8"	3/4"

Recommended Gas Pipe Diameter

Note: Never use plastic pipe. Check to confirm whether your local codes allow copper tubing or galvanized.

Note: Since some municipalities have additional local codes, it is always best to consult your local authority and installation code.

The use of the following gas connectors is recommended:

- ANS Z21.24 Appliance Connectors of Corrugated Metal Tubing and Fittings
- ANS Z21.45 Assembled Flexible Appliance Connectors of Other Than All-Metal Construction

The above connectors may be used if acceptable by the authority having jurisdiction. The state of Massachusetts requires that a flexible appliance connector cannot exceed three feet in length.

FLEXIBLE GAS LINE CONNECTION

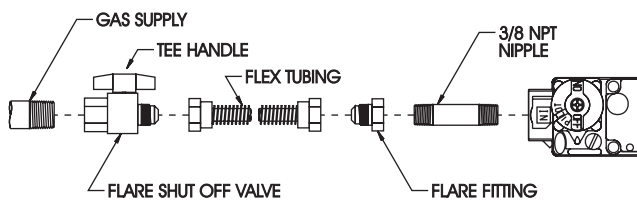

RIGID GAS LINE CONNECTION

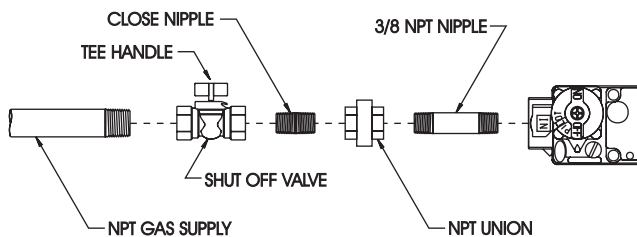

Figure 1

Consult the current National Fuel Gas Code, ANSI Z223.1 CAN/CGA-B149 (.1 or .2) installation code.

Installing a New Main Gas Cock

Each appliance should have its own manual gas cock.

A manual main gas cock should be located in the vicinity of the unit. Where none exists, or where its size or location is not adequate, contact your local authorized installer for installation or relocation.

Compounds used on threaded joints of gas piping shall be resistant to the action of liquefied petroleum gases. The gas lines must be checked

for leaks by the installer. This should be done with a soap solution watching for bubbles on all exposed connections, and if unexposed, a pressure test should be made.

Never use an exposed flame to check for leaks. Appliance must be disconnected from piping at inlet of control valve and pipe capped or plugged for pressure test. Never pressure test with appliance connected; control valve will sustain damage!

A gas valve and ground joint union should be installed in the gas line upstream of the gas control to aid in servicing. It is required by the National Fuel Gas Code that a drip line be installed near the gas inlet. This should consist of a vertical length of pipe tee connected into the gas line that is capped on the bottom in which condensation and foreign particles may collect.

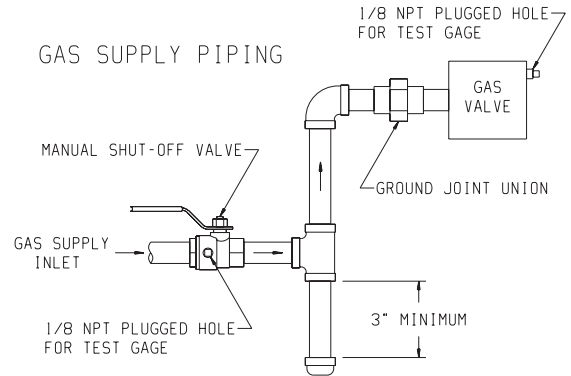

Figure 2 - Method of Installing a Tee Fitting Sediment Trap

Pressure Testing of the Gas Supply System

1. To check the inlet pressure to the gas valve, a 1/8" (3mm) N.P.T. plugged tapping, accessible for test gauge connection, must be placed immediately upstream of the gas supply connection to the appliance.
2. The appliance and its individual shutoff valve must be disconnected from the gas supply piping system during any pressure testing of that system at test pressures in excess of 1/2 psig (3.5 kPa)
3. The appliance must be isolated from the gas supply piping system by closing its individual manual shutoff valve during any pressure testing of the gas supply piping system at test pressures equal to or less than 1/2 psig (3.5 kPa).

Attention! If one of the above procedures results in pressures in excess of 1/2 psig (14" w.c.) (3.5 kPa) on the appliance gas valve, it will result in a hazardous condition.

Checking Manifold Pressure

Both Propane and Natural gas valves have a built-in pressure regulator in the gas valve. Natural gas models will have a manifold pressure of approximately 4.0" w.c. (.996kPa) at the valve outlet with the inlet pressure to the valve from a minimum of 5.0" w.c. (1.245kPa) for the purpose of input adjustment to a maximum of 10.5" w.c. (2.61kPa). Propane gas models will have a manifold pressure approximately 10.0" w.c. (2.49kPa) at the valve outlet with the inlet pressure to the valve from a minimum of 11.0" w.c. (2.739kPa) for the purpose of input adjustment to a maximum of 13.0" w.c. (3.23kPa).

A 1/8" (3mm) N.P.T. plugged tapping, accessible for test gauge connection, is located on the outlet side of the gas control.

CLEARANCES

Clearances: When facing the front of the room heater the minimum clearances to combustible construction (material) are the following:

Left side - 6 inches (152mm)

Right side - 6 inches (152mm)

Recommend 18 inches (457mm) on left side for servicing

Do not install in alcove or closet.

No horizontal projection above heater permitted within 55 inches (140 cm).

Ceiling 55 inches (140cm)

Draft hood to rear wall 2 inches (51 mm)

Open in front to provide service, access, and clearance to construction.

VENTING

1. Flue pipe must be as large as the flue collar on the draft diverter.
2. Maintain an upward slope of at least 1/4 inch (6mm) per foot of horizontal run.
3. Run flue pipe as directly as possible with a minimum of elbows.
4. Flue pipe should extend through the wall of a chimney to be flush with inner wall.
5. Flue pipe must be adequately supported by metal strips.
6. Single wall vent pipe may be attached directly to the draft hood of the room heater when clearance of 2 1/2 inches (64mm) is maintained between the single wall vent pipe and the combustible wall of the room in which the room heater is located. Use double wall vent pipe for 1 inch (25mm) clearance to combustibles.
7. For flue pipe running through walls and roof, use B-1 [1 inch (25mm) clearance to combustibles] vent pipe.
8. Chimneys should extend at least 2 feet (.6m) above the roof and above any object or nearby building within 10 feet (3m).
9. Open tees should not be used in the flue pipe.
10. Appliance must not be connected to a chimney flue that is servicing a separate solid-fuel burning appliance.

For proper venting, do not attach a 90° elbow directly to draft diverter. If possible, attach 2 feet (.6m) of straight vent pipe before an elbow is used. Use of 45° elbows is recommended.

Uninsulated single-wall metal pipe shall not be used outdoors in cold climates for venting gas utilization equipment.

Ventilation and Combustion Air

Room heaters shall be installed in a location in which the facilities for ventilation permit satisfactory combustion of gas and proper venting under normal conditions. In buildings of conventional frame, brick or stone construction without tight storm windows and doors, infiltration is normally adequate to provide for combustion and draft hood dilution.

Where appliances are installed in a confined space within a building, the building being of unusually tight construction, air for combustion and ventilation must be obtained directly from outdoors or from such spaces that freely communicate with the outdoors. Under these conditions, the confined space shall be provided with two permanent openings, one near the top of the enclosure and one near the bottom; each opening shall have a free area of not less than one square inch (6.5cm²) per 1,000 BTU's (.3KW) of total input. The draft hood must be in the same atmospheric pressure zone as the combustion air inlet to the appliance.

Liner and Insulated Liner

When you install a vented room heater into a masonry chimney you must follow these steps.

1. The chimney must be lined and sized properly. Most masonry chimneys are over sized and absorb too much heat to be considered a proper vent. If you have any doubts line the chimney with the right size liner. If it's unlined you must line it.
2. Use an insulated liner when the chimney is on the outside, three sides exposed to the weather, and there is no clay liner in the chimney. The insulation will help keep the flue gases warmer.

Insulated Vent Enclosure

Vented room heaters installed with the vent going directly to the outside and above the eaves can cause poor venting. The cold pipe will have a delay in proper venting and cause the room heater to shut "off" by the vent safety switch. To prevent delayed venting as well as condensation of flue products an insulated enclosure is recommended.

Use type B 5" (127mm) diameter vent pipe and maintain at least a one inch (25mm) clearance to combustibles.

Use metal thimble to protect vent pipe as it passes through combustibles.

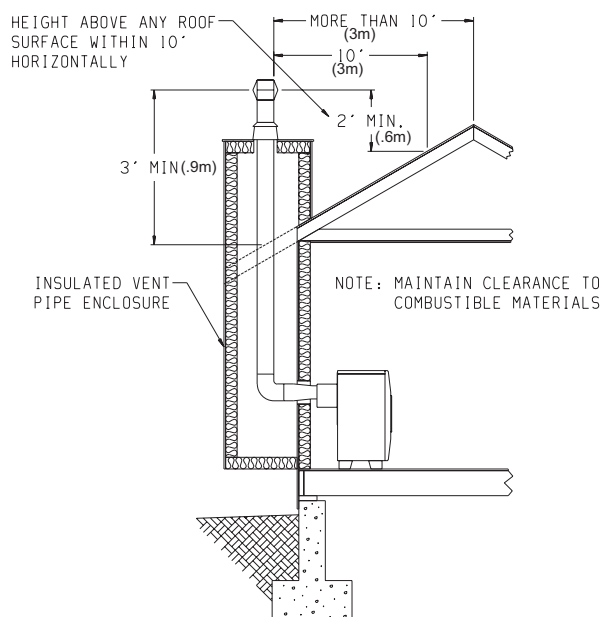

Figure 3

VENT SAFETY SHUTOFF SYSTEM

This heater must be properly connected to a venting system. This heater is equipped with a vent safety shutoff system.

Warning:

Operation of this heater, when not connected to a properly installed and maintained venting system or tampering with the vent safety shutoff system, can result in carbon monoxide (CO) poisoning and possible death.

This appliance needs fresh air for safe operation and must be installed so there are provisions for adequate combustion and ventilation air.

This room heater is equipped with a vent safety switch. The vent safety switch will cause gas flow to the pilot to “shut off” due to improper venting or a blocked flue.

If the vent safety switch continues to “shut off” the gas flow to the pilot, a qualified service person must be contacted to inspect for improper venting, blockage in the vent pipe or the vent safety switch for being defective.

REVERSIBLE VERTICAL OR HORIZONTAL DRAFT DIVERTER

This room heater has a reversible draft diverter. The draft diverter is installed in the vertical position at the factory. Please use the following steps to change the draft diverter from the vertical position to the horizontal position.

1. Remove L280 vent safety switch from the draft diverter.
2. Inside your yellow instruction envelope will be a 1 1/2” x 2 1/4” (38mm x 51mm) vent safety switch hole cover plate and two (2) 1/2” screws for attachment of vent safety switch hole cover plate to the draft diverter. Attach vent safety switch hole cover plate over hole on the draft diverter from which the L280 vent safety switch was removed.
3. Remove two (2) screws at bottom of draft diverter and lift upward to remove draft diverter from the draft diverter plate. Rotate draft diverter into the horizontal position and slide back into the draft diverter plate. Attach two (2) screws into bottom of the drafter diverter.
4. Remove vent safety switch hole knockout and two (2) knockouts for screws on opposite side of draft diverter.
5. Attach L280 vent safety switch to the draft diverter.
6. Repositioning of the draft diverter is completed.

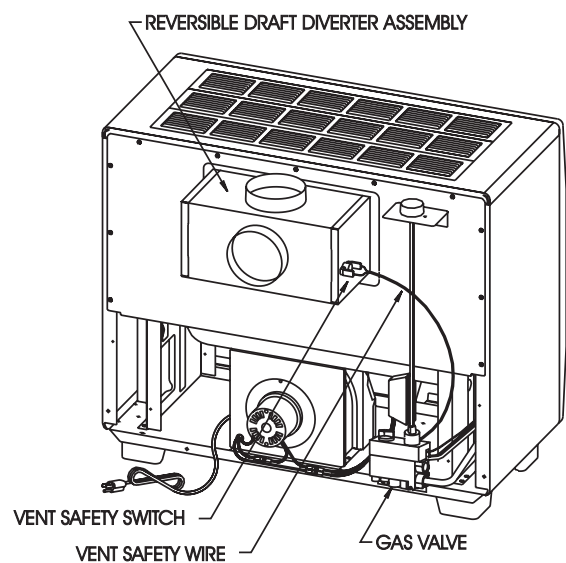

DRAFT DIVERTER CAN BE EITHER A VERTICAL VENT OR HORIZONTAL VENT

Figure 4

THERMOSTAT OPERATION

To turn on burner, rotate dial knob toward setting number 7. To shut down burner, rotate dial knob toward setting number 1.

The dial numbers 1 to 7 correspond to 50° to 90°F (10° to 32°C). This temperature at the bulb thermostat, not the room temperature. The owner is advised to determine the particular heat setting that is desired for comfort, as heating requirements are different for every owner.

Attention: If no heat is desired, turn the gas control knob to the PILOT position.

LIGHTING INSTRUCTIONS

FOR YOUR SAFETY READ BEFORE LIGHTING

WARNING: If you do not follow these instructions exactly, a fire or explosion may result causing property damage, personal injury or loss of life.

A. This appliance has a pilot which must be lighted by hand. When lighting the pilot, follow these instructions exactly.

B. BEFORE LIGHTING smell all around the appliance area for gas. Be sure to smell next to the floor because some gas is heavier than air and will settle on the floor.

WHAT TO DO IF YOU SMELL GAS

- Do not try to light any appliance.
- Do not touch any electrical switch; do not use any phone in your building.
- Immediately call your gas supplier from a neighbor's phone, Follow the gas supplier's instructions.

• If you cannot reach your gas supplier, call the fire department.

C. Use only your hand to push in or turn the gas control knob. Never use tools. If the knob will not push in or turn by hand, don't try to repair it; call a qualified service technician. Force or attempted repair may result in a fire or explosion.

D. Do not use this appliance if any part has been under water. Immediately call a qualified service technician to inspect the appliance and to replace any part of the control system and any gas control which has been under water.

LIGHTING INSTRUCTIONS

1. STOP! Read the safety information above on this label.
2. Set thermostat to lowest setting.
3. Turn off all electric power to the appliance (if applicable).
4. Remove access panel (front panel).

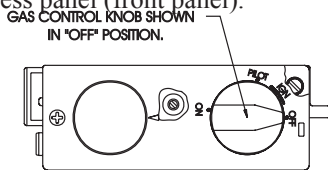

5. Push in gas control knob slightly and turn clockwise to "OFF." Do not force. 
6. Wait ten (10) minutes to clear out any gas. Then, smell for gas, including near the floor. If you smell gas, STOP! Follow "B" in the safety information above on this label. If you do not smell gas, go to the next step.

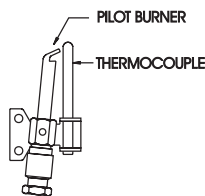

7. Find pilot - the pilot is attached to front of burner.
8. Turn gas control knob counterclockwise to "IGN." 

9. Depress and turn gas control knob counterclockwise  to "PILOT." A spark is produced when gas control knob is turned between "IGN" and "PILOT." Repeatedly depress and turn gas control knob between "IGN" and "PILOT" until pilot is ignited. Continue to hold the control knob in for about one (1) minute after pilot is lit. Release knob and it will pop back up. If it goes out, repeat steps 5 through 9.
 - If knob does not pop up when released, stop and immediately call your service technician or gas supplier.
 - If the pilot will not stay lit after several tries, turn the gas control knob to "OFF" and call your service technician or gas supplier.

10. Attention! Gas control has INTERLOCK latching device. When the pilot is initially lit and the safety magnet is energized (pilot stays on) the INTERLOCK latching device becomes operative. If the gas control is turned to the "OFF" position or gas flow to the appliance is shut off, the pilot cannot be relighted until the safety magnet is de-energized (approximately 60 seconds). There will be an audible "click" when the safety magnet in the gas control is de-energized. Pilot can now be relighted. Repeat steps 5 through 9.

11. Turn the gas control knob counterclockwise  to "ON."
12. Turn on all electric power to the appliance (if applicable).
13. Replace access panel (front panel). Set thermostat to desired setting.

TO TURN OFF GAS APPLIANCE

1. Set the thermostat to lowest setting.
2. Turn off all electric power to the appliance (if applicable), if service is to be performed.

3. Push in gas control knob slightly and turn clockwise  to "OFF." Do not force.

PILOT FLAME CHARACTERISTICS

The correct flame will be almost horizontal, blue and will extend past the thermocouple 1/4" (6mm). The flame will surround the thermocouple just below the tip.

On Propane (LP-gas) slight yellow might occur where the pilot flame and the burner flame meet.

Natural gas pilots require adjusting when the inlet pressure is above 5" w.c. (1.25kPa). Remove pilot adjustment cover. Turn adjustment screw clockwise to reduce flame.

Propane (LP-gas) will not require adjusting.

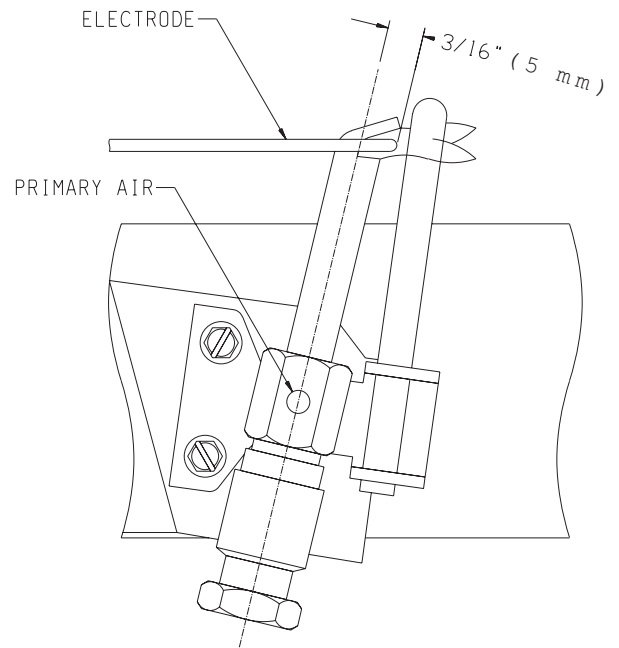

Figure 5

MAIN BURNER FLAME CHARACTERISTICS

There will be a short blue inner flame with a larger, lighter blue secondary flame. The burner flame may have yellow tips when hot. Dust in the combustion air will produce an orange or red flame. Do not mistake the orange or red flame for an improper yellow flame. The flame will be proper if the factory-set pressure and orifice are used. After use, cleaning may be required for the proper flame.

On Propane gas, if a whistling noise (resonance) occurs

- Screw the air adjustment bolt into the burner throat to eliminate the whistling noise (resonance).
- Size main burner orifice with a drill bit. For RH-50(C) use #47 drill bit. For RH-65(C) use 2.3mm drill bit.

Primary Air Adjustment see page 11.

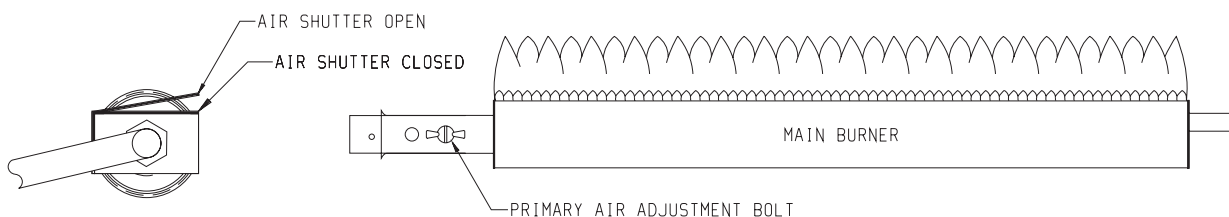

Figure 6

MAINTENANCE

Cleaning Pilot Burner

After use, cleaning of the pilot burner may be required for the proper flame. The pilot orifice can be cleaned with high pressure air or by placing under running water. Pilot orifice must be dry before replacement. Use a pipe cleaner to clean inside the pilot after the pilot orifice has been removed.

Removing Pilot Orifice

1. Disconnect the pilot supply line at the pilot burner
2. Remove pilot orifice from pilot burner. It may be necessary to tap on pilot burner in order to remove the pilot orifice.

Cleaning Main Burner

Remove the burner and apply water pressure inside the throat of the burner and down into the ports; follow with air pressure.

Removing Main Burner

1. Remove casing front.
2. Disconnect pilot bracket from the burner.
3. Remove brass nut from burner.
4. Disconnect burner from chamber leg flange.
5. Remove burner from bottom of combustion chamber.

Cleaning Combustion Chamber

A qualified serviceman should remove the chamber and apply air pressure to the inside in order to clear all passageways.

Primary Air Adjustment

1. A primary air adjustment bolt is located on left, front of burner throat. The bolt can be screwed into burner throat to REDUCE primary air or unscrewed from burner throat to INCREASE primary air. To reduce yellow flame on main burner, unscrew bolt from burner throat. Also, refer to Step 2. To reduce resonance (whistling) noise or extinction (popping) noise, screw bolt into burner throat.
2. An air shutter bracket is attached to top of burner throat. The air shutter bracket lays flat across top of burner throat. If yellow flames can not be removed from main burner by using primary air adjustment bolt, the air shutter bracket can be pivoted upward to allow additional primary air to enter burner throat.

On Propane gas, if a whistling noise (resonation) occurs, screw the air adjustment bolt into the burner throat to eliminate the whistling noise (resonation).

TROUBLESHOOTING

1. Impossible to light pilot

- a. If using piezo ignitor, check electrode location.
- b. Remove nut at orifice and check for gas.
- c. If gas available, check for blocked orifice or pilot.

2. Pilot outage

- a. Proper size of pilot flame.
- b. Defective or weak thermocouple.

3. Pilot flames but goes out

- a. Pilot flame not covering the thermocouple properly when knob is released.
- b. Defective thermocouple.
- c. Defective magnet in the safety section of valve.

4. Poor thermostatic control

- a. Thermostat needs calibrating.
- b. Defective thermostat section.

5. Noisy blower

- a. Tighten blower screws.
- b. Check blower wheel in the open for balance.

6. Yellow main burner flame

- a. Remove main burner to check for obstructions in throat, ports and orifices.
- b. Install new main burner orifice and pilot orifice
- c. Check gas valve for leaking.
- d. Open the air bolt on the main burner in order to increase the amount of primary air.

7. Yellow pilot flame

- a. Small yellow tip not objectionable.
- b. Remove pilot orifice. Check and clean.

8. Pilot and main burner go out after burning a few minutes

- a. Improper venting of flue products. Relight and check for improper venting.
- b. If vented properly, check vent safety switch, replace if defective.

9. Burner back-flashes or 'pops' and burns and main burner orifice.

- a. Examine burner for defects.

10. Inoperative blower

- a. Check fan control by shorting across terminals.
- b. Check for blower wheel bind by removing wheel and operating motor.
- c. Check for frozen bearings due to lack of oil.

PARTS LIST RH-50 & RH-65

PLEASE NOTE: When ordering parts, it is very important that part number and description of part coincide.

Index No.	Part No.	Description	Index No.	Part No.	Description
1	11723	Diverter Assembly	24	RH-457	Air Shutter Bracket
2	RH-802	Down Draft Shield (RH-50-6 NAT & LPG-RH-65-6 NAT)	25	P-267	Manifold Assembly (RH-50-6)
2	RH-851	Down Draft Shield (RH-65-6 LPG)	25	P-268	Manifold Assembly (RH-65-6)
3	11724	Draft Diverter Plate	26	P86-3.7mm	Main Burner Orifice (RH-65-6 Nat)
4	11719	Casing Top (RH-50-6)	26	P86-3.1mm	Main Burner Orifice (RH-50-6 Nat)
4	11720	Casing Top (RH-65-6)	26	P86-2.3mm	Main Burner Orifice (RH-65-6 LPG)
5	11707	Louver (RH-50-6, 3 required) (RH-65-6, 4 required)	26	P86-47	Main Burner Orifice (RH-50-6 LPG)
6	11745	Casing Back	27	11746	Valve Bracket
7	RH-652	Combustion Chamber Assembly (RH-50-6)	28	R-6101	Gas Valve (Nat)
7	RH-626	Combustion Chamber Assembly (RH-65-6)	28	R-6102	Gas Valve (LPG)
8	RH-654	Chamber Shield - Right (RH-50-6)	29	11743	Control Rod
8	RH-655	Chamber Shield - Right (RH-65-6)	30	11700	Control Rod Bracket
9	11721	Casing Side (RH-50-6)	31	R-2708	Piezo Ignitor
9	11722	Casing Side (RH-65-6)	32	R-6096	Knob & Adaptor Set
10	RH-060	Radian Glass with Rope Gasket	33	11728	Motor Mounting Plate
11	R-369	Blower Wheel	34	R-587	Motor Cushion
12	11727	Blower Housing and Chute Assembly	35	R-2605	Motor
13	RH-520	Glass Frame Assembly	36	11722	Casing Side (RH-65-6)
14	RH-138	Blower Cushion	36	11721	Casing Side (RH-50-6)
15	RH-618	Inner Front	37	RH-653	Chamber Shield - Left
16	11725	Casing Bottom Assembly (RH-50-6)	38	R-2099	Cord Set
16	11726	Casing Bottom Assembly (RH-65-6)	39	RH-656	Chamber Shield - Rear
17	RH-853	Burner	40	R-2091	Wire Assembly
18	11717	Casing Front with Heat Shield (USA)	41	R-1468	Strain Relief Bushing
18	15674	Casing Front with Heat Shield (Canada)	42	R-896	Bushing
19	R-776	Thermocouple	43	R-1156	Fan Control Switch
20	RH-620	Pouch	44	RH-863	Switch Box Assembly
21	R-775L	Pilot Burner with Orifice (LPG)	45	DV-807	Switch Box Cover
21	R-775N	Pilot Burner with Orifice (Nat)	46	R-8195	ECO Wire Assembly
22	R-6126	Electrode and Wire Assembly	47	R-2706	Eco Switch
23	11712	Pilot Tubing (RH-50-6)	Not Shown	742148	Pilot Orifice .011 (Nat)
23	11713	Pilot Tubing (RH-65-6)	Not Shown	742250	Pilot Orifice .008 (LPG)
			Not Shown	RH-527	Glass and Frame Assembly (Includes 10 and 13)
			Not Shown	R-1630	ECO Adapter
			Not Shown	UH-441	Vent Safety Switch/ECO Hole Cover Plate

USE ONLY MANUFACTURER'S REPLACEMENT PARTS. USE OF ANY OTHER PARTS COULD CAUSE INJURY OR DEATH.

PARTS VIEW RH-50 & RH-65

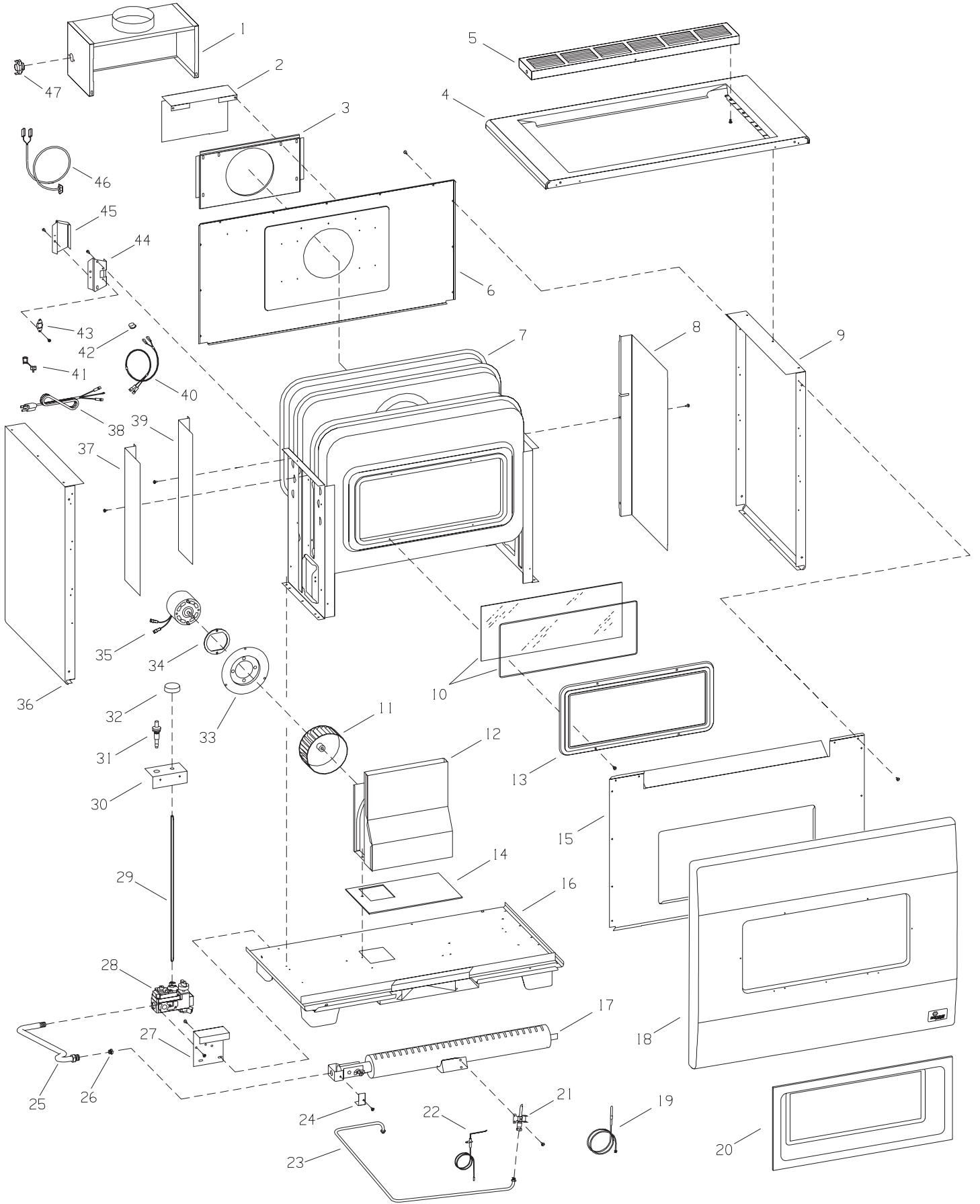

PARTS LIST RH-50C & RH-65C

PLEASE NOTE: When ordering parts, it is very important that part number and description of part coincide.

Index No.	Part No.	Description	Index No.	Part No.	Description
1	11723	Diverter Assembly	18	R-6126	Electrode and Wire Assembly
2	RH-802	Down Draft Shield (RH-50C-1 NAT & LPG)	19	11712	Pilot Tubing (RH-50C-1)
2	RH-851	Down Draft Shield (RH-65C-1 NAT & LPG)	19	11713	Pilot Tubing (RH-65C-1)
3	11724	Draft Diverter Plate	20	RH-457	Air Shutter Bracket
4	11719	Casing Top (RH-50C-1)	21	P-267	Manifold Assembly (RH-50C-CB-1)
4	11720	Casing Top RH-65C-1)	21	P-268	Manifold Assembly (RH-65C-1)
5	11707	Louver (RH-50C-1, 3 Required) (RH-65C-1, 4 Required)	22	P86-3.7mm	Main Burner Orifice (RH-65C-1 NAT)
6	11745	Casing Back	22	P86-3.1mm	Main Burner Orifice (RH-50C-1 NAT)
7	11741	Combustion Chamber Assembly (RH-50C-1)	22	P86-2.3mm	Main Burner Orifice (RH-65C-1 LPG)
7	11742	Combustion Chamber Assembly (RH-65C-1)	22	P86-47	Main Burner Orifice (RH-50C-1 LPG)
8	RH-654	Chamber Shield - Right (RH-50C-1)	23	11746	Valve Bracket
8	RH-655	Chamber Shield - Right (RH-65C-1)	24	R-6101	Gas Valve (NAT)
9	11721	Casing Side (RH-50C-1)	24	R-6102	Gas Valve (LPG)
9	11722	Casing Side (RH-65C-1)	25	11743	Control Rod
10	RH-618	Inner Front	26	11700	Control Rod Bracket
11	RH-625	Bottom Reflector (RH-50C-1)	27	R-6096	Knob & Adaptor Set
11	RH-660	Bottom Reflector (RH-65C-1)	28	11722	Casing Side (RH-65C-1)
12	RH-624	Rear Shield	28	11721	Casing Side (RH-50C-1)
13	11725	Casing Bottom Assembly (RH-50C-1)	29	RH-653	Chamber Shield - Left
13	11726	Casing Bottom Assembly (RH-65C-1)	30	RH-656	Chamber Shield - Rear
14	RH-853	Burner	31	R-8195	ECO Wire Assembly
15	11755	Casing Front Assembly (USA)	32	R-2706	Eco Switch
15	15675	Casing Front Assembly (Canada)	Not Shown	742148	Pilot Orifice .011 (NAT)
16	R-776	Thermocouple	Not Shown	742250	Pilot Orifice 0.008 (LPG)
17	R-775L	Pilot Burner with Orifice (LPG)	Not Shown	R-1630	ECO Adaptor
17	R-775N	Pilot Burner with Orifice (NAT)	Not Shown	UH-441	Vent Safety Switch/ECO Hole Cover Plate

USE ONLY MANUFACTURER'S REPLACEMENT PARTS. USE OF ANY OTHER PARTS COULD CAUSE INJURY OR DEATH.

PARTS VIEW RH-50C & RH-65C

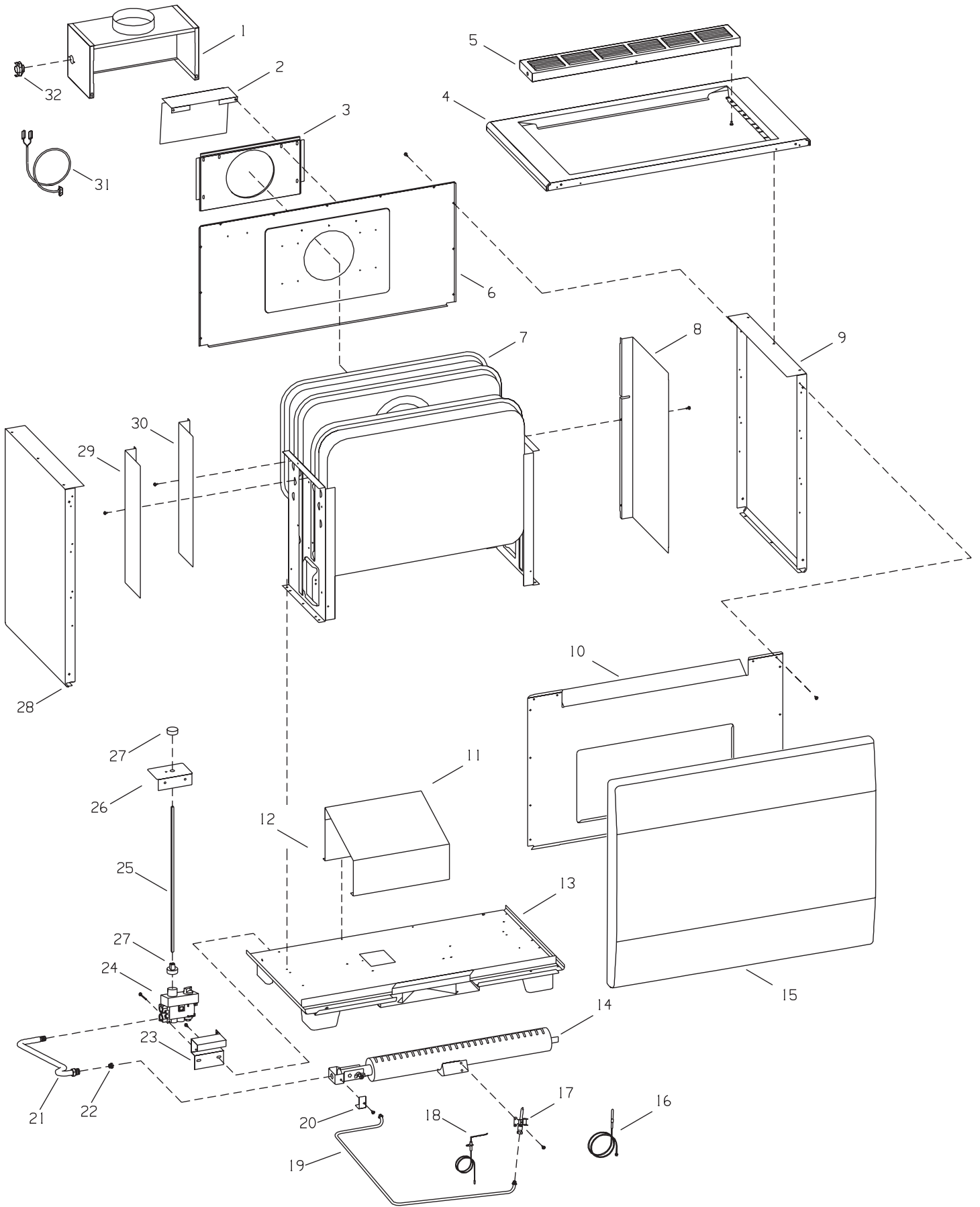

OPTIONAL BLOWER INSTALLATION INSTRUCTIONS

FRB-3 For Vented Room Heaters Models

RH-50-(1, 2, 3, 4, 5, 6) RH-50C-1
RH-65-(1, 2, 3, 4, 5, 6) RH-65C-1

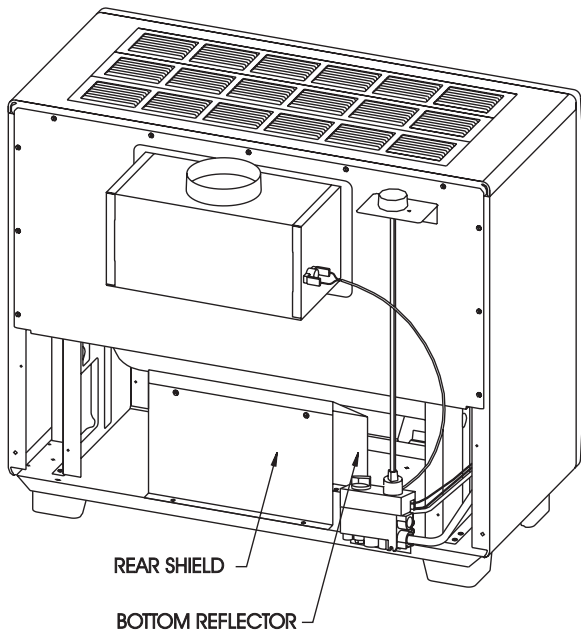

Figure 1

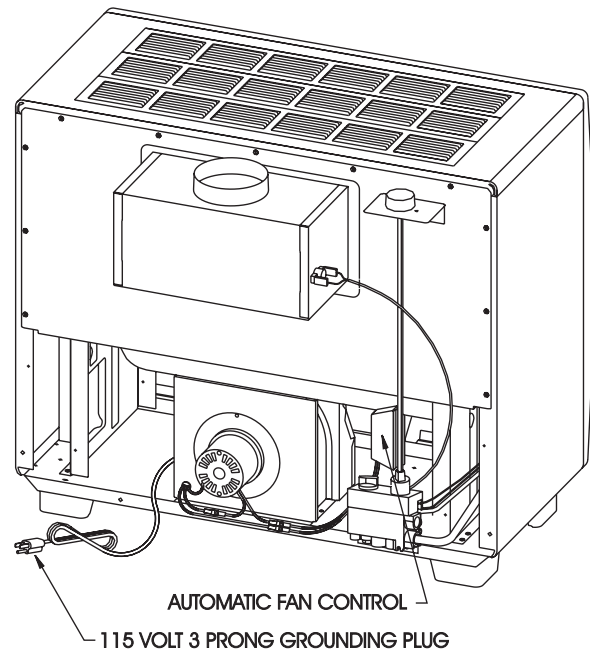

Figure 2

Installing Optional Blower

1. Remove rear shield (2 screws) and bottom reflector (4 screws). (See Figure 1)
2. Align blower cushion with bottom assembly air discharge opening. Foil face side of blower cushion should be placed upward.
3. Align blower housing with blower cushion and use two #10 x 1/2" (13mm) hex-head screws to attach blower housing to bottom assembly. (See Figure 2)
4. Save bottom reflector and rear shield (removed in Step 1) in the event the blower housing is removed from room heater. **Attention! Bottom reflector and rear shield must be attached to bottom assembly whenever the blower housing is removed from the room heater and the room heater is in operation.**
5. Remove switch box cover from the switch box by removing the #8 x 1/4" (6mm) hex-head screw.
6. There are two screw holes on the lower back of the combustion chamber. Use only the left screw hole for mounting.
7. With the switch box perpendicular to the combustion chamber, align the round clearance hole on the switch box with the left screw hole on the combustion chamber (See Figure 3).
8. Attach switch box to the combustion chamber using the #10 x 1/2" (13mm) hex-head screw provided.
9. Attach switch box cover to the switch box by using the #8 x 1/4" (6mm) hex-head screw. (See Figure 4)

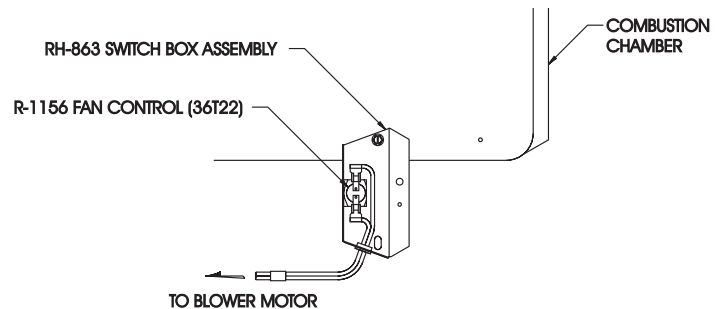

Figure 3

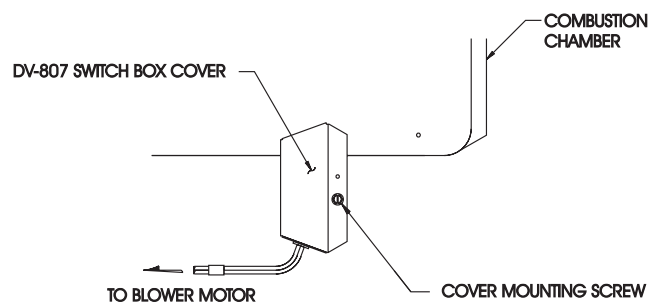

Figure 4

Attention: Wiring harness on blower is factory assembled and installed. If wiring harness becomes disassembled, use the following steps to reassemble the wiring harness.

1. Attach (1) pin terminal from black (hot) wire, smooth insulation on cord set to (1) socket terminal on fan control assembly.
2. Attach (1) pin terminal from black (neutral) wire, ribbed insulation on cord set to (1) socket terminal from white (neutral) wire on motor.
3. Attach (1) pin terminal on fan control assembly to (1) socket terminal from black (hot) wire on motor.
4. Attach green ground wire beneath one of the #10 x 1/2" (13mm) screws on the blower housing.

Fan Control

The automatic fan control is located in the switch box. The switch box is attached to the front of the blower assembly. The switch box is adjacent to the combustion chamber. The fan control is a non-adjustable automatic type. The fan control will require between 5 and 10 minutes of main burner operation before the fan control “closes” and activates the blower. The blower will continue to run between 5 and 10 minutes after the main burner shuts off, before the fan control “opens” and deactivates the blower.

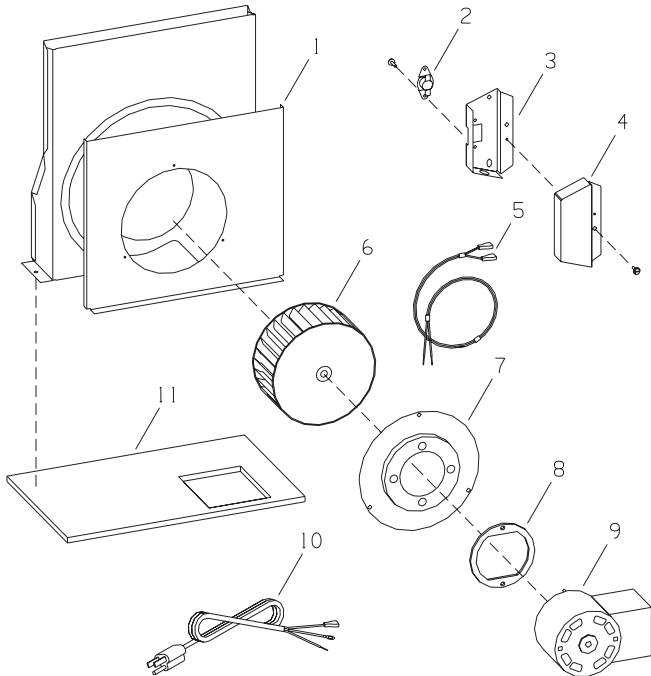

Index No.	Part No.	Description
1	11727	Blower Housing and Chute Assembly
2	9120106	Fan Control Switch
3	RH-863	Switch Box
4	DV-807	Switch Box Cover
5	R-2091	Wire Assembly
6	642031	Blower Wheel
7	11728	Motor Mounting Plate
8	632016	Motor Cushion
9	R-2605	Motor
10	8720161	Strain Relief Bushing
11	R-2099	Cord Set
12	RH-138	Blower Cushion

Wiring

The appliance, when installed, must be electrically grounded in accordance with local codes or, in the absence of local codes, with the *National Electrical Code, ANSI/NFPA 70* or *Canadian Electrical Code, CSA C22.1*, if an external electrical source is utilized. **This appliance is equipped with a three-prong [grounding] plug for your protection against shock hazard and should be plugged directly into a properly grounded three-prong receptacle. Do not cut or remove the grounding prong from this plug.** For an ungrounded receptacle, an adapter, which has two prongs and a wire for grounding, can be purchased, plugged into the ungrounded receptacle and its wire connected to the receptacle mounting screws. With this wire completing the ground, the appliance cord plug can be plugged into the adapter and be electrically grounded. A 7/8" (22mm) hole is provided in the junction box for use with a conduit connector if local codes require this type of protection.

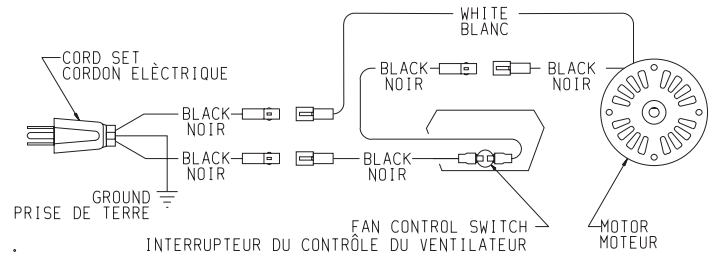

Wiring Diagram

If any of the original wire as supplied with the appliance must be replaced, it must be replaced with type 125°C wire or its equivalent.

CAUTION: Label all wires prior to disconnection when servicing controls. Wiring errors can cause improper and dangerous operation. Verify proper operation after servicing.

Warning:
Unplugging of blower accessory will not stop the heater from cycling. To shut heater off:
 1. Turn temperature dial or thermostat to lowest setting.
 2. Turn knob n gas control to “OFF,” depressing slightly.
Do not force.

Cleaning

The blower wheel will collect lint and could require cleaning once a year. If the air output decreases or the noise level increases, it indicates a dirty wheel. Complete removal of the wheel and scrubbing it with a brush under flowing water is recommended.

Oiling

The blower motor has an oil hole located on each end of the motor. Use #20 motor oil only. It is best to oil the motor several times during the heating season using 2 or 3 drops each time. If the motor fails to start and hums, it could be a tight bearing due to lack of oil. This may be corrected by pouring kerosene in the oil holes, allowing to stand for a few hours and then oiling properly.

MASTER PARTS DISTRIBUTOR LIST

To Order Parts Under Warranty, please contact your local Empire dealer. See the dealer locator at www.empirecomfort.com. To provide warranty service, your dealer will need your name and address, purchase date and serial number, and the nature of the problem with the unit.

To Order Parts After the Warranty Period, please contact your dealer or one of the Master Parts Distributors listed below. This list changes from time to time. For the current list, please click on the Master Parts button at www.empirecomfort.com.

Please note: Master Parts Distributors are independent businesses that stock the most commonly ordered Original Equipment repair parts for Heaters, Grills, and Fireplaces manufactured by Empire Comfort Systems Inc.

Star-Fire Distributors

1355 Evans Avenue
Akron, OH 44305

Phone: 330-630-2794

Toll Free: 800-875-6220

Fax: 330-633-8701

Parts: Heater & Hearth and Grills

Dey Distributing

1401 Willow Lake Boulevard
Vadnais Heights, MN 55101

Phone: 651-490-9191

Toll Free: 800-397-1339

Website: www.deyistributing.com

Parts: Heater & Hearth

East Coast Energy Products

10 East Route 36
West Long Branch, NJ 07764

Phone: 732-870-8809

Toll Free: 800-755-8809

Fax: 732-870-8811

Website: www.eastcoastenergy.com

Parts: Heater & Hearth and Grills

Victor Division of F. W. Webb Company

200 Locust Street
Hartford, CT 06114

Phone: 860-722-2433

Toll Free: 800-243-9360

Fax: 860-293-0479

Toll Free Fax: 800-274-2004

Websites: www.fwwebb.com & www.victormfg.com

Parts: Heater & Hearth and Grills

HOW TO ORDER REPAIR PARTS

Parts Not Under Warranty

Parts can be ordered through your Service Person, Dealer, or a Master Parts Distributor. See this page for the Master Parts Distributors list. For best results, the **service person or dealer** should order parts through the distributor. Parts can be shipped directly to the **service person/dealer**.

Warranty Parts

Warranty parts will need a proof of purchase and can be ordered by your Service Person or Dealer. Proof of purchase is **required** for warranty parts.

All parts listed in the Parts List have a Part Number. When ordering parts, first obtain the Model Number from the name plate on your equipment. Then determine the Part Number (**not** the Index Number) and the Description of each part from the following appropriate illustration and list. Be sure to give all this information . . .

Appliance Number _____ Part Description _____

Appliance Serial Number _____ Part Number _____

Type of Gas (Propane or Natural) _____

Do not order bolts, screws, washers or nuts. They are standard hardware items and can be purchased at any local hardware store.

Shipments contingent upon strikes, fires and all causes beyond our control.



Empire Comfort Systems Inc.
918 Freeburg Ave. Belleville, IL 62220

If you have a general question about our products, please e-mail us at
info@empirecomfort.com.

If you have a service or repair question, please contact your dealer.

www.empirecomfort.com